

June 1995

8A, 700V - 1000V Ultrafast Dual Diodes

Features

- Ultrafast with Soft Recovery <85ns
- Operating Temperature +175°C
- Reverse Voltage Up To 1000V
- Avalanche Energy Rated
- Planar Construction

Applications

- Switching Power Supplies
- Power Switching Circuits
- General Purpose

Description

RURP870CC, RURP880CC, RURP890CC and RURP8100CC are ultrafast dual diodes with soft recovery characteristics ($t_{RR} < 85ns$). They have low forward voltage drop and are silicon nitride passivated ion-implanted epitaxial planar construction.

These devices are intended for use as freewheeling/clamping diodes and rectifiers in a variety of switching power supplies and other power switching applications. Their low stored charge and ultrafast soft recovery minimize ringing and electrical noise in many power switching circuits reducing power loss in the switching transistors.

PACKAGE AVAILABILITY

PART NUMBER	PACKAGE	BRAND
RURP870CC	TO-220AB	RURP870C
RURP880CC	TO-220AB	RURP880C
RURP890CC	TO-220AB	RURP890C
RURP8100CC	TO-220AB	RUR8100C

NOTE: When ordering, use the entire part number.
Formerly developmental type TA09617.

Package

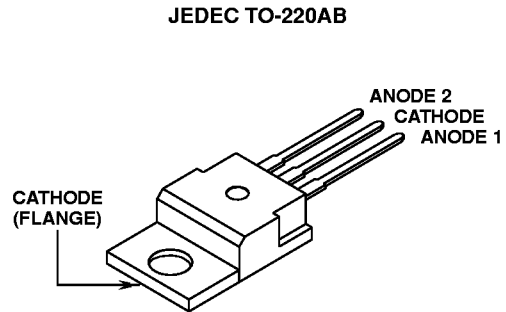

Symbol

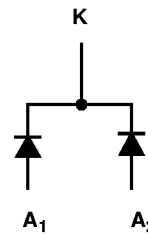

Absolute Maximum Ratings (per leg) $T_C = +25^\circ C$, Unless Otherwise Specified

	RURP870CC	RURP880CC	RURP890CC	RURP8100CC	UNITS
Peak Repetitive Reverse Voltage V_{RRM}	700	800	900	1000	V
Working Peak Reverse Voltage V_{RWM}	700	800	900	1000	V
DC Blocking Voltage V_R	700	800	900	1000	V
Average Rectified Forward Current $I_{F(AV)}$ $T_C = +155^\circ C$	8	8	8	8	A
Repetitive Peak Surge Current I_{FSM} Square Wave, 20kHz	16	16	16	16	A
Nonrepetitive Peak Surge Current I_{FSM} Halfwave, 1 Phase, 60Hz	100	100	100	100	A
Maximum Power Dissipation P_D	75	75	75	75	W
Avalanche Energy (See Figures 10 and 11) E_{AVL}	20	20	20	20	mj
Operating and Storage Temperature T_{STG}, T_J	-65 to +175	-65 to +175	-65 to +175	-65 to +175	°C

Specifications RURP870CC, RURP880CC, RURP890CC, RURP8100CC

Electrical Specifications (per leg) $T_C = +25^\circ\text{C}$, Unless Otherwise Specified

SYMBOL	TEST CONDITION	LIMITS												UNITS
		RURP870CC			RURP880CC			RURP890CC			RURP8100CC			
		MIN	TYP	MAX	MIN	TYP	MAX	MIN	TYP	MAX	MIN	TYP	MAX	
V_F	$I_F = 8\text{A}, T_C = +25^\circ\text{C}$	-	-	1.8	-	-	1.8	-	-	1.8	-	-	1.8	V
	$I_F = 8\text{A}, T_C = +150^\circ\text{C}$	-	-	1.6	-	-	1.6	-	-	1.6	-	-	1.6	V
I_R	$V_R = 700\text{V}, T_C = +25^\circ\text{C}$	-	-	100	-	-	-	-	-	-	-	-	-	μA
	$V_R = 800\text{V}, T_C = +25^\circ\text{C}$	-	-	-	-	-	100	-	-	-	-	-	-	μA
	$V_R = 900\text{V}, T_C = +25^\circ\text{C}$	-	-	-	-	-	-	-	-	100	-	-	-	μA
	$V_R = 1000\text{V}, T_C = +25^\circ\text{C}$	-	-	-	-	-	-	-	-	-	-	-	100	μA
I_R	$V_R = 700\text{V}, T_C = +150^\circ\text{C}$	-	-	500	-	-	-	-	-	-	-	-	-	μA
	$V_R = 800\text{V}, T_C = +150^\circ\text{C}$	-	-	-	-	-	500	-	-	-	-	-	-	μA
	$V_R = 900\text{V}, T_C = +150^\circ\text{C}$	-	-	-	-	-	-	-	-	500	-	-	-	μA
	$V_R = 1000\text{V}, T_C = +150^\circ\text{C}$	-	-	-	-	-	-	-	-	-	-	-	500	μA
t_{RR}	$I_F = 1\text{A}, dI_F/dt = 200\text{A}/\mu\text{s}$	-	-	85	-	-	85	-	-	85	-	-	85	ns
	$I_F = 8\text{A}, dI_F/dt = 200\text{A}/\mu\text{s}$	-	-	100	-	-	100	-	-	100	-	-	100	ns
t_A	$I_F = 8\text{A}, dI_F/dt = 200\text{A}/\mu\text{s}$	-	50	-	-	50	-	-	50	-	-	50	-	ns
t_B	$I_F = 8\text{A}, dI_F/dt = 200\text{A}/\mu\text{s}$	-	30	-	-	30	-	-	30	-	-	30	-	ns
Q_{RR}	$I_F = 8\text{A}, dI_F/dt = 200\text{A}/\mu\text{s}$	-	500	-	-	500	-	-	500	-	-	500	-	nC
C_J	$V_R = 10\text{V}, I_F = 0\text{A}$	-	30	-	-	30	-	-	30	-	-	30	-	pF
$R_{\theta JC}$		-	-	2.0	-	-	2.0	-	-	2.0	-	-	2.0	$^\circ\text{C}/\text{W}$

DEFINITIONS

V_F = Instantaneous forward voltage (pw = 300 μs , D = 2%).

I_R = Instantaneous reverse current.

t_{RR} = Reverse recovery time (Figure 2), summation of $t_A + t_B$.

t_A = Time to reach peak reverse current (See Figure 2).

t_B = Time from peak I_{RM} to projected zero crossing of I_{RM} based on a straight line from peak I_{RM} through 25% of I_{RM} (See Figure 2).

Q_{RR} = Reverse recovery charge.

C_J = Junction Capacitance.

$R_{\theta JC}$ = Thermal resistance junction to case.

E_{AVL} = Controlled Avalanche Energy (See Figures 10 and 11).

pw = pulse width.

D = duty cycle.

V_1 AMPLITUDE CONTROLS I_F
 V_2 AMPLITUDE CONTROLS dI_F/dt
 L_1 = SELF INDUCTANCE OF $R_4 + L_{LOOP}$

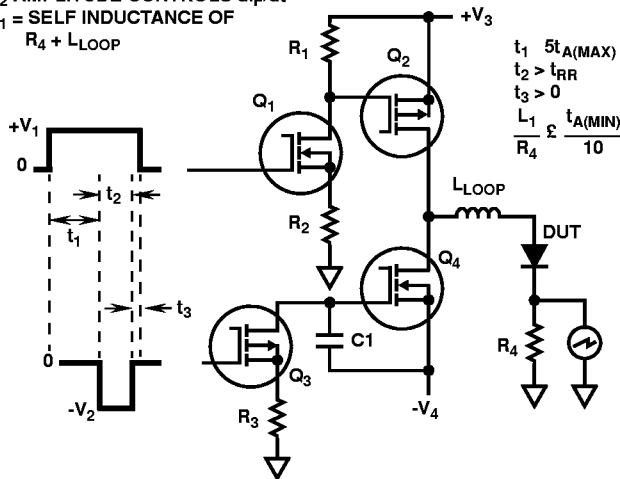

FIGURE 1. t_{RR} TEST CIRCUIT

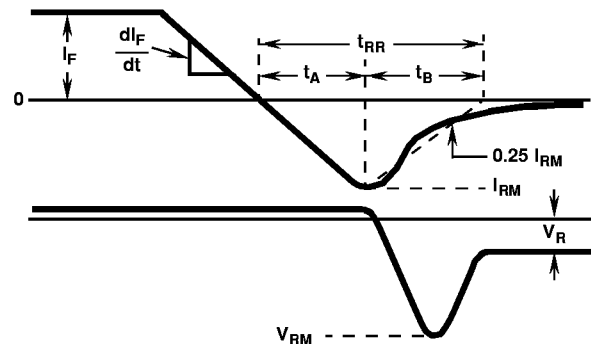

FIGURE 2. t_{RR} WAVEFORMS AND DEFINITIONS

Typical Performance Curves

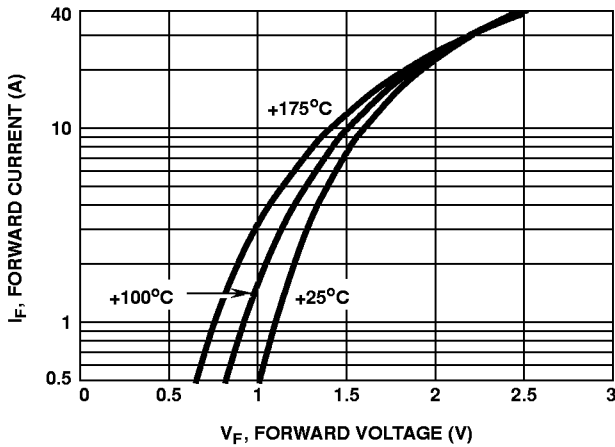

FIGURE 3. TYPICAL FORWARD CURRENT vs FORWARD VOLTAGE DROP

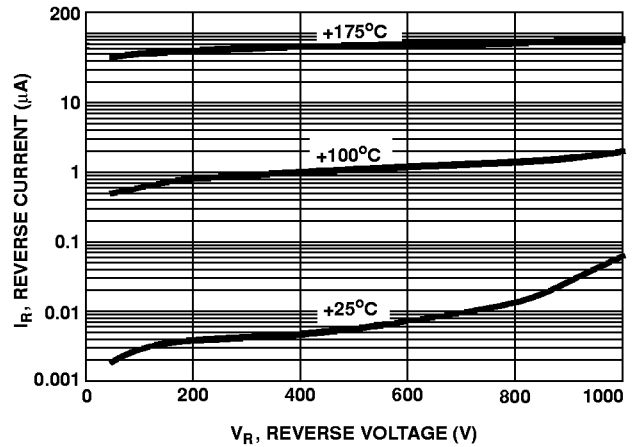

FIGURE 4. TYPICAL REVERSE CURRENT vs REVERSE VOLTAGE

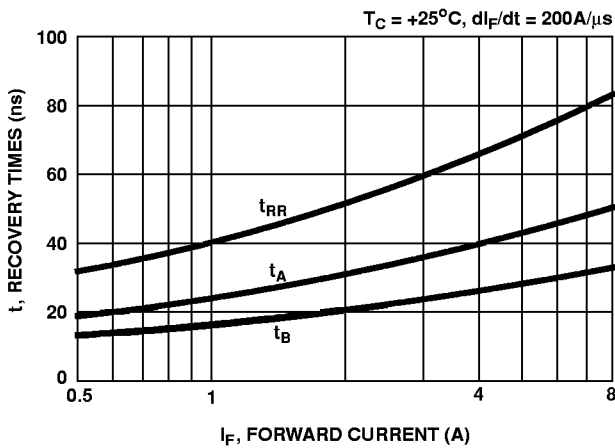

FIGURE 5. TYPICAL t_{RR} , t_A AND t_B CURVES vs FORWARD CURRENT AT 25°C

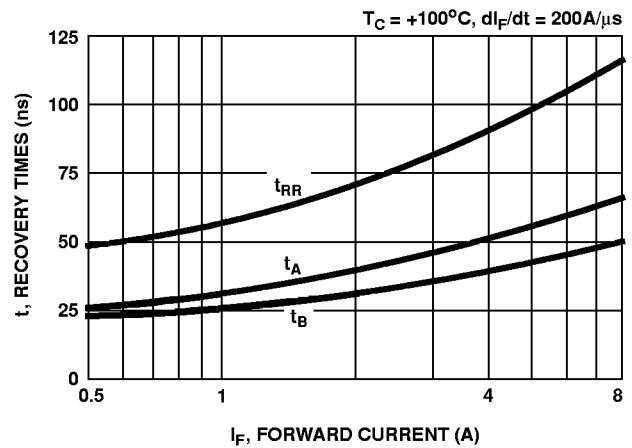

FIGURE 6. TYPICAL t_{RR} , t_A AND t_B CURVES vs FORWARD CURRENT AT 100°C

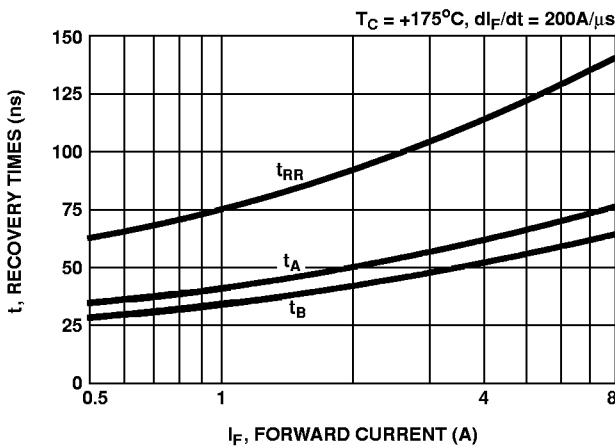

FIGURE 7. TYPICAL t_{RR} , t_A AND t_B CURVES vs FORWARD CURRENT AT 175°C

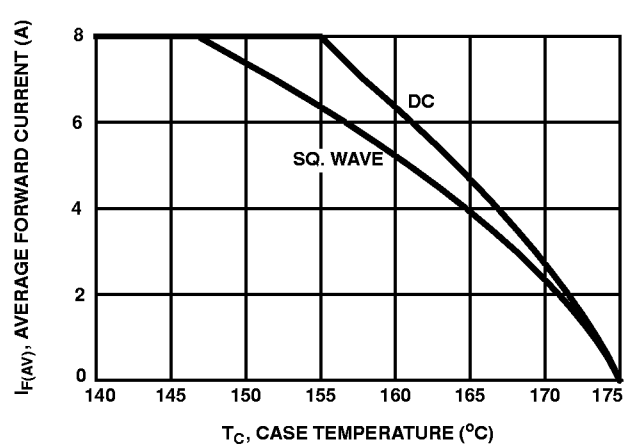

FIGURE 8. CURRENT DERATING CURVE FOR ALL TYPES

Typical Performance Curves (Continued)

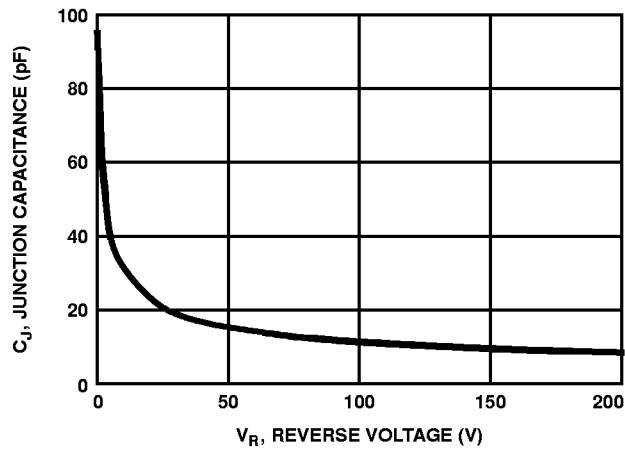

FIGURE 9. TYPICAL JUNCTION CAPACITANCE vs REVERSE VOLTAGE

Test Circuits and Waveforms

$L = 40\text{mH}$
 $R < 0.1\Omega$
 $E_{AVL} = 1/2LI^2 [V_{AVL}/(V_{AVL} - V_{DD})]$
 Q_1 AND Q_2 ARE 1000V MOSFETS

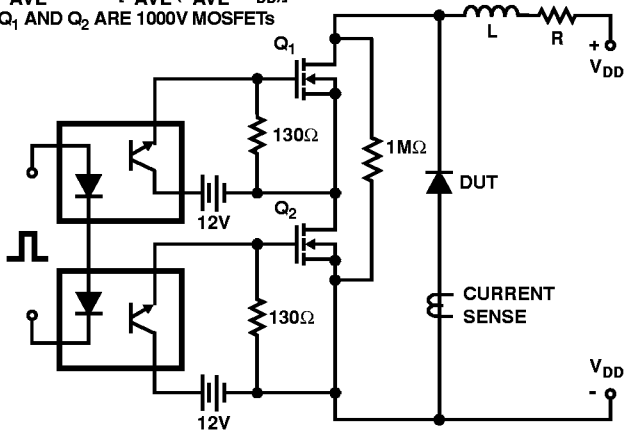

FIGURE 10. AVALANCHE ENERGY TEST CIRCUIT

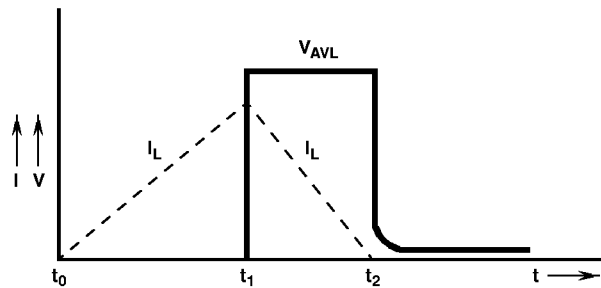
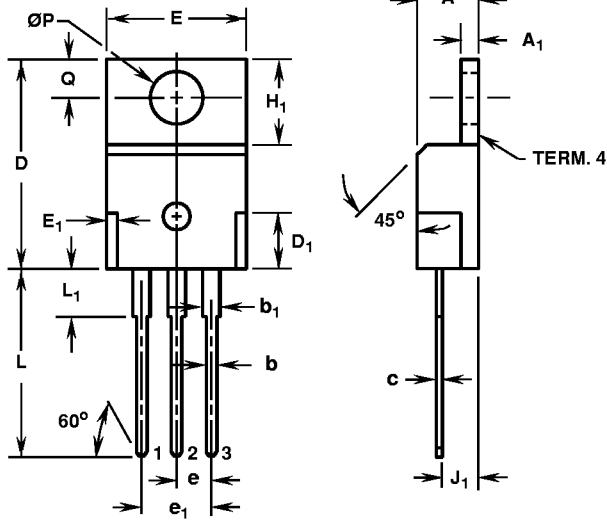

FIGURE 11. AVALANCHE CURRENT AND VOLTAGE WAVEFORMS

RURP870CC, RURP880CC, RURP890CC, RURP8100CC

Packaging



LEAD 1. ANODE 1
 LEAD 2. CATHODE
 LEAD 3. ANODE 2
 TERMINAL 4. CATHODE

TO-220AB

3 LEAD JEDEC TO-220AB PLASTIC PACKAGE

SYMBOL	INCHES		MILLIMETERS		NOTES
	MIN	MAX	MIN	MAX	
A	0.170	0.180	4.32	4.57	-
A ₁	0.048	0.052	1.22	1.32	-
b	0.030	0.034	0.77	0.86	3, 4
b ₁	0.045	0.055	1.15	1.39	2, 3
c	0.014	0.019	0.36	0.48	2, 3, 4
D	0.590	0.610	14.99	15.49	-
D ₁	-	0.160	-	4.06	-
E	0.395	0.410	10.04	10.41	-
E ₁	-	0.030	-	0.76	-
e	0.100 TYP		2.54 TYP		5
e ₁	0.200 BSC		5.08 BSC		5
H ₁	0.235	0.255	5.97	6.47	-
J ₁	0.100	0.110	2.54	2.79	6
L	0.530	0.550	13.47	13.97	-
L ₁	0.130	0.150	3.31	3.81	2
ØP	0.149	0.153	3.79	3.88	-
Q	0.102	0.112	2.60	2.84	-

NOTES:

1. These dimensions are within allowable dimensions of Rev. J of JEDEC TO-220AB outline dated 3-24-87.
2. Lead dimension and finish uncontrolled in L₁.
3. Lead dimension (without solder).
4. Add typically 0.002 inches (0.05mm) for solder coating.
5. Position of lead to be measured 0.250 inches (6.35mm) from bottom of dimension D.
6. Position of lead to be measured 0.100 inches (2.54mm) from bottom of dimension D.
7. Controlling dimension: Inch.
8. Revision 1 dated 1-93.