

## Features

- PT8A995 works as encoder and PT8A9961/9962/9963/9964 work as decoders
- Supply voltage: 3.3V to 6.0V
- Internal auto-shutdown function
- Internal over-load protection to meet HD271 safety specification (996x)
- Integrated RF circuit (995)
- Two analog channels, one for tachospeed and the other for steering
- 32 steps for each of two analog channels
- Fine tuning selection for two analog channels
- Few external components needed
- Closed loop adjustment for servo motor (996x)
- Built-in voltage regulator (996x)
- Package: 16-pin DIP (995P), 20-pin DIP (996xP), 20-pin SOIC (996xS), see Ordering Information.

## Applications

- Remote Controller
- Toys
- Remote Measurement

## Ordering Information

Part Number	Package
PT8A995PE	Lead free 16-pin DIP
PT8A996xPE	Lead free 20-pin DIP
PT8A996xSE	Lead free and Green 20-pin SOIC

**Note:** x means 1-4 to show different part no.

Adding E=Pb-free or Pb-free and Green

Adding X suffix=Tape/Reel

## Description

The PT8A995 and PT8A996x provide a simple and economic solution for basic Digital Proportional R/C car toys. The chipset uses CMOS LSI Analog and Mixed Signal technology. They provide high quality encoder/decoder circuit.

PT8A995 serves as an encoder. To obtain accurate timing easily, Manchester encoding is employed. Some digital modulation scheme can be used, e.g., general ASK, OOK, FSK and QPSK. OOK is easy to implement and low cost.

The PT8A996x provides a simple and cost effective solution for basic Digital Proportional R/C car toys with PT8A995 together. RF circuit in receiver side can demodulate RF signal. The demodulated signal will be amplified and filtered. After that, the base-band signal is formed. DPLL is adopted to generate sampling clock. An internal A/D converter is required to make servo motor work well. The inputs are SRV and OFFSET. Overload protection mechanism is built-in to meet Toy Safety Requirement.

The PT8A996x provide four solutions for toy car by different capability Servo.

PT8A9961	PT8A9962	PT8A9963	PT8A9964
mini car	small car	middle car	large car

## Block Diagram

Figure 1. Block Diagram of PT8A995

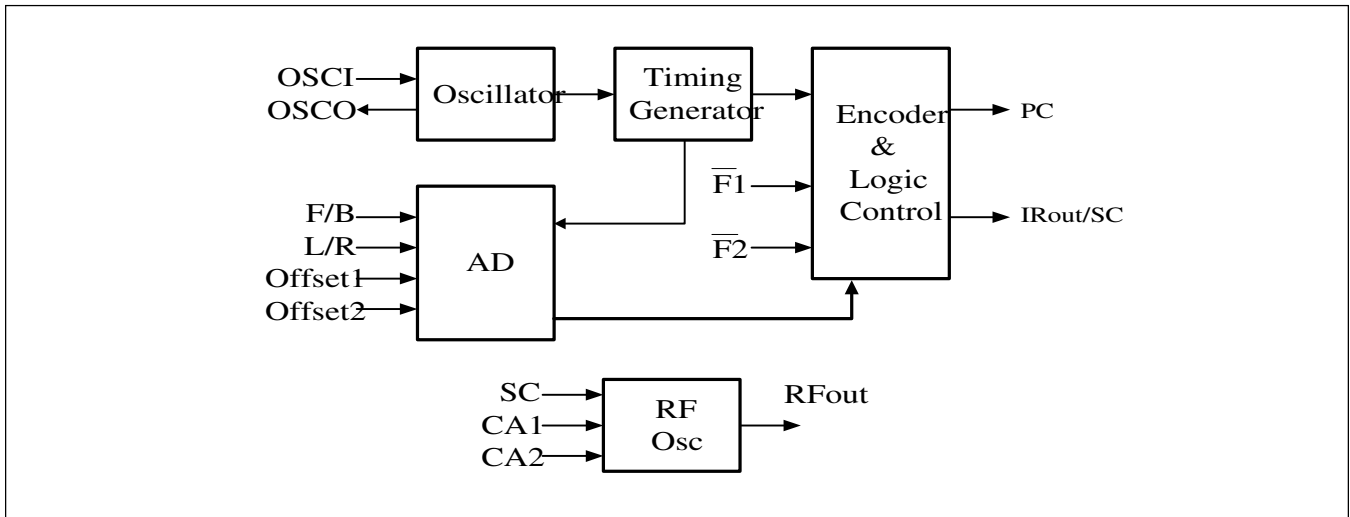
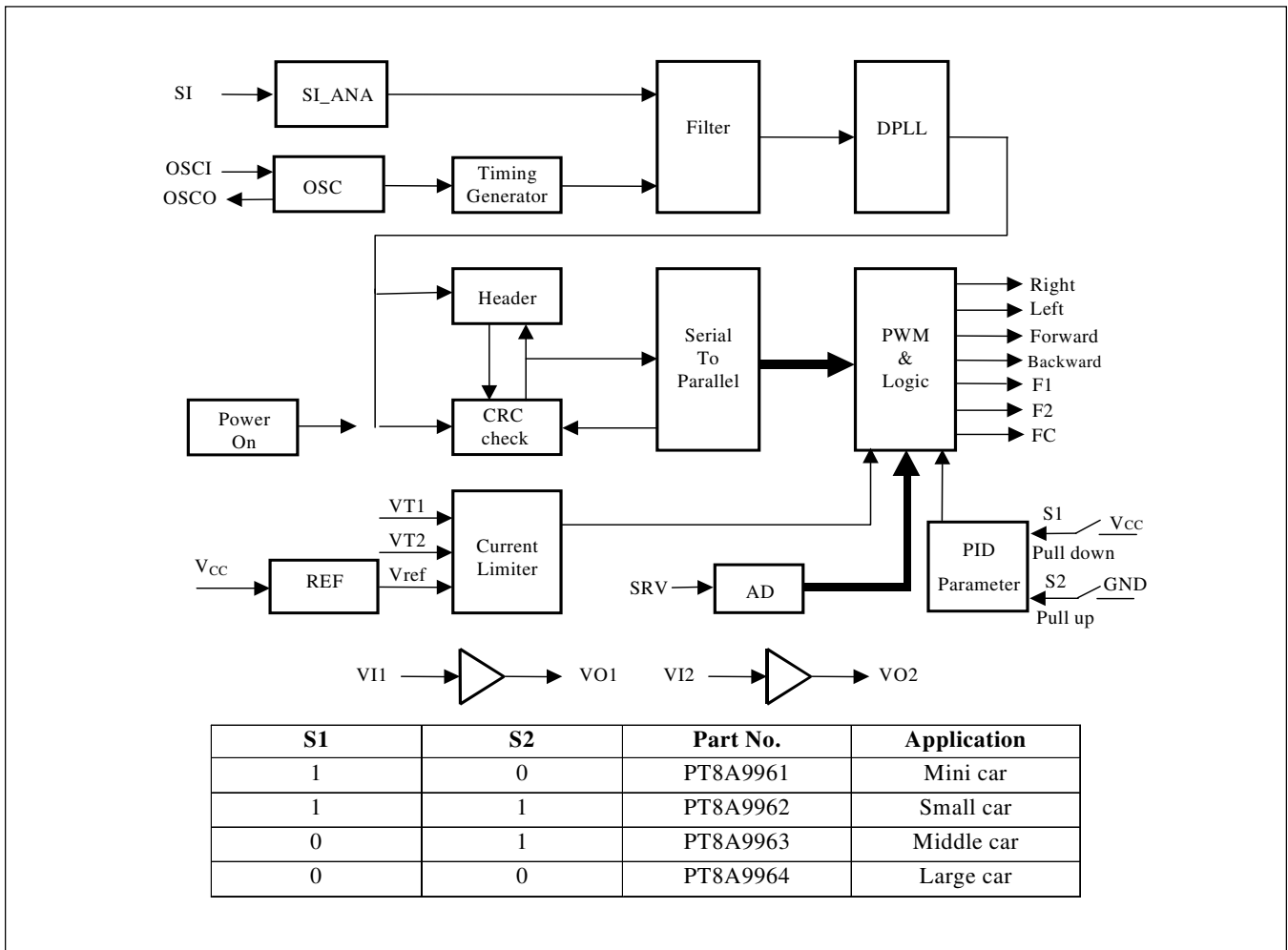
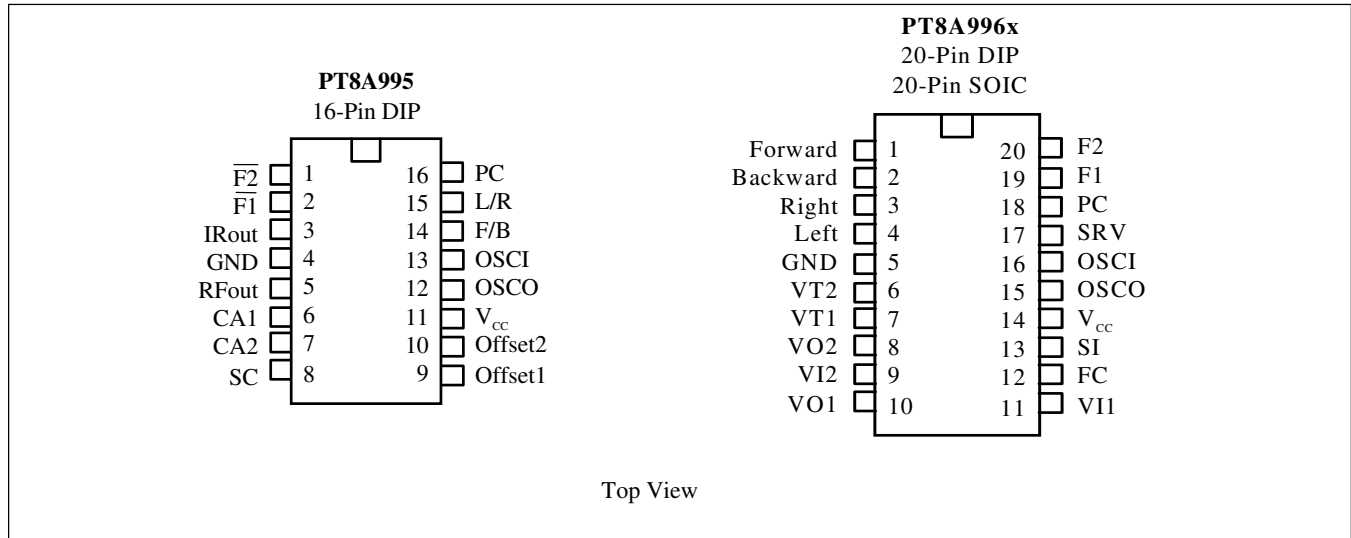


Figure 2. Block Diagram of PT8A9961/9962/9963/9964



## Pin Configuration



## Pin Description

Table 1. Pin Description of PT8A995

Pin No.	Pin name	Description
1	$\overline{F2}$	F2 function control pin
2	$\overline{F1}$	F1 function control pin
3	IRout	Output code with 38KHz carries
4	GND	Ground
5	RFout	Output code with 27M or 49MHz carries
6	CA1	27M or 49MHz crystal oscillator input
7	CA2	27M or 49MHz crystal oscillator output
8	SC	Output code
9	Offset1	Used for offset adjustment of speed input
10	Offset2	Used for offset adjustment of steering input
11	V <sub>cc</sub>	power
12	OSCO	Crystal oscillator output
13	OSCI	Crystal oscillator input
14	F/B	Input for forward & backward speed
15	L/R	Input for steering angle left & right
16	PC	Power control output

**Table 2. Pin Description of PT8A9961/9962/9963/9964**

Pin No.	Pin Name	Description
1	Forward	Forward output
2	Backward	Backward output
3	Right	Right output
4	Left	Left output
5	GND	GND
6	VT2	F/B motor current limit protection input
7	VT1	L/R motor current limit protection input
8	VO2	The second stage amplify output
9	VI2	The second stage amplify input
10	VO1	The first stage amplify output
11	VI1	The first stage amplify input
12	FC	Futaba connection output
13	SI	Encode signal input
14	V <sub>cc</sub>	Power
15	OSCO	Crystal oscillator output
16	OSCI	Crystal oscillator input
17	SRV	Servo motor feedback input
18	PC	Auto power off control
19	F1	Function1 control
20	F2	Function2 control

## Maximum Ratings

(Above which the useful life may be impaired. For user guidelines, not tested)

Storage Temperature .....	-25°C to +85°C	<b>Note:</b> Stresses greater than those listed under MAXIMUM RATINGS may cause permanent damage to the device. This is a stress rating only and functional operation of the device at these or any other conditions above those indicated in the operational sections of this specification is not implied. Exposure to absolute maximum rating conditions for extended periods may affect reliability.
Ambient Temperature with Power Applied .....	0°C to +70°C	
Supply Voltage to Ground Potential (Inputs & V <sub>cc</sub> Only) .....	-0.5 to +7.0V	
Supply Voltage to Ground Potential (Outputs & D/O Only) ...	-0.5 to +7.0V	
DC Input Voltage .....	-0.5 to +7.0V	
DC Output Current .....	20mA	
Power Dissipation .....	500mW	

## Recommended Operation Conditions

Sym	Description	Test Conditions	Min	Typ	Max	Units
V <sub>CC</sub>	Supply Voltage	-	4.0	-	5.5	V
V <sub>IH</sub>	Input HIGH Voltage	-	0.7V <sub>CC</sub>	-	V <sub>CC</sub>	V
V <sub>IL</sub>	Input LOW Voltage	-	0	-	0.3V <sub>CC</sub>	V
F <sub>OSC</sub>	Oscillator Frequency	-	400	455	500	kHz
T <sub>A</sub>	Operation Temperature	-	0	-	70	°C

## DC Electrical Characteristics

Sym	Description	Pin	Test Conditions	Min	Typ	Max	Units
I <sub>CC</sub>	Supply Current		Clock = 455kHz, outputs unloaded	-	-	3	mA
I <sub>STB</sub>	Standby Current		-	-	-	500	uA
I <sub>OH</sub>	Output HIGH Current	Function pins	V <sub>IN</sub> = V <sub>CC</sub> -0.5V	-8	-	-	mA
	Output HIGH Current	PC		-15	-	-	mA
I <sub>OL</sub>	Output LOW Current	Function pins	V <sub>OUT</sub> = 0.5V	8	-	-	mA
	Output LOW Current	PC		-	-	60	uA
I <sub>IH</sub>	Input HIGH Current	VT1, VT2	V <sub>IN</sub> = V <sub>CC</sub>	-	-	60	uA
	Input HIGH Current	SI, OSC1		-	-	10	uA
	Input HIGH Current	Other input pins		-	-	1	uA
I <sub>IL</sub>	Input LOW Current	SI, OSC1	V <sub>IN</sub> = 0V	-	-	-10	uA
	Input LOW Current	Other input pins		-	-	-1	uA

**Note:** These specifications apply for V<sub>CC</sub> = 5.0V and 0°C ≤ T<sub>A</sub> ≤ 70°C, unless otherwise specified.

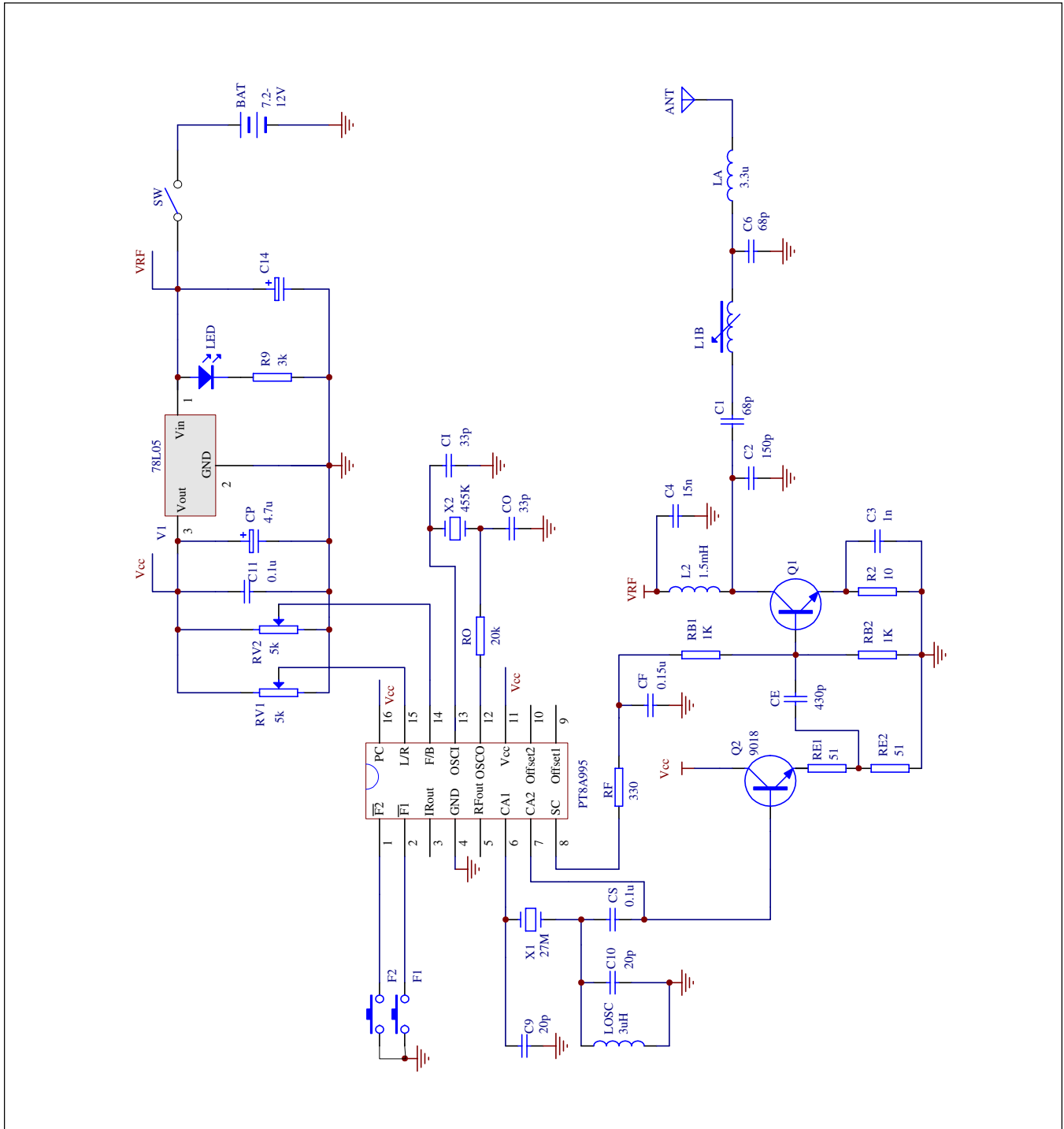
## AC Electrical Characteristics

Sym	Description	Test Conditions	Min	Typ	Max	Units
f <sub>OSC</sub>	Oscillator Frequency	R <sub>f</sub> = 200kΩ	400	455	500	kHz
f <sub>t</sub>	Frequency Tolerance	-	-	-	1.5	%
t <sub>R</sub>	Response Time*	f <sub>OSC</sub> = 455kHz	-	-	90	ms
R <sub>I</sub>	Inverter Input Resistance	Apply for VI1 & VI2, R <sub>f</sub> = 2.2MΩ	50	-	-	kΩ
R <sub>O</sub>	Inverter Output Resistance	Apply for VO1 & VO2	-	-	10	kΩ
V <sub>T</sub>	Overload Protection	-	0.3	0.4	0.5	V

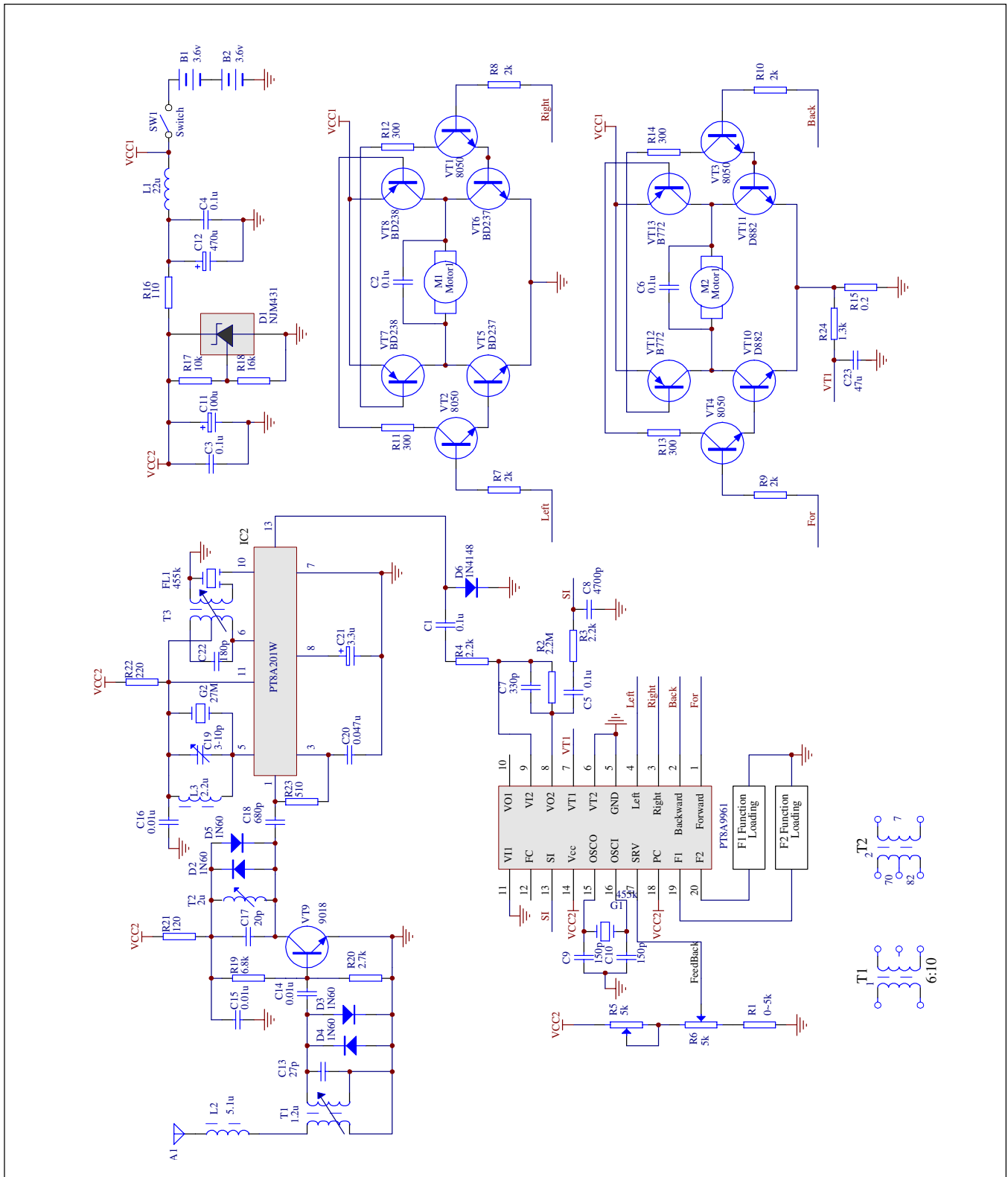
**Note:** These specifications apply for V<sub>CC</sub> = 5.0V and 0°C ≤ T<sub>A</sub> ≤ 70°C, unless otherwise specified.

\* The time from the transmitter's control to the receiver σ response.

**Figure 3. Application of PT8A995 with External Modulation**

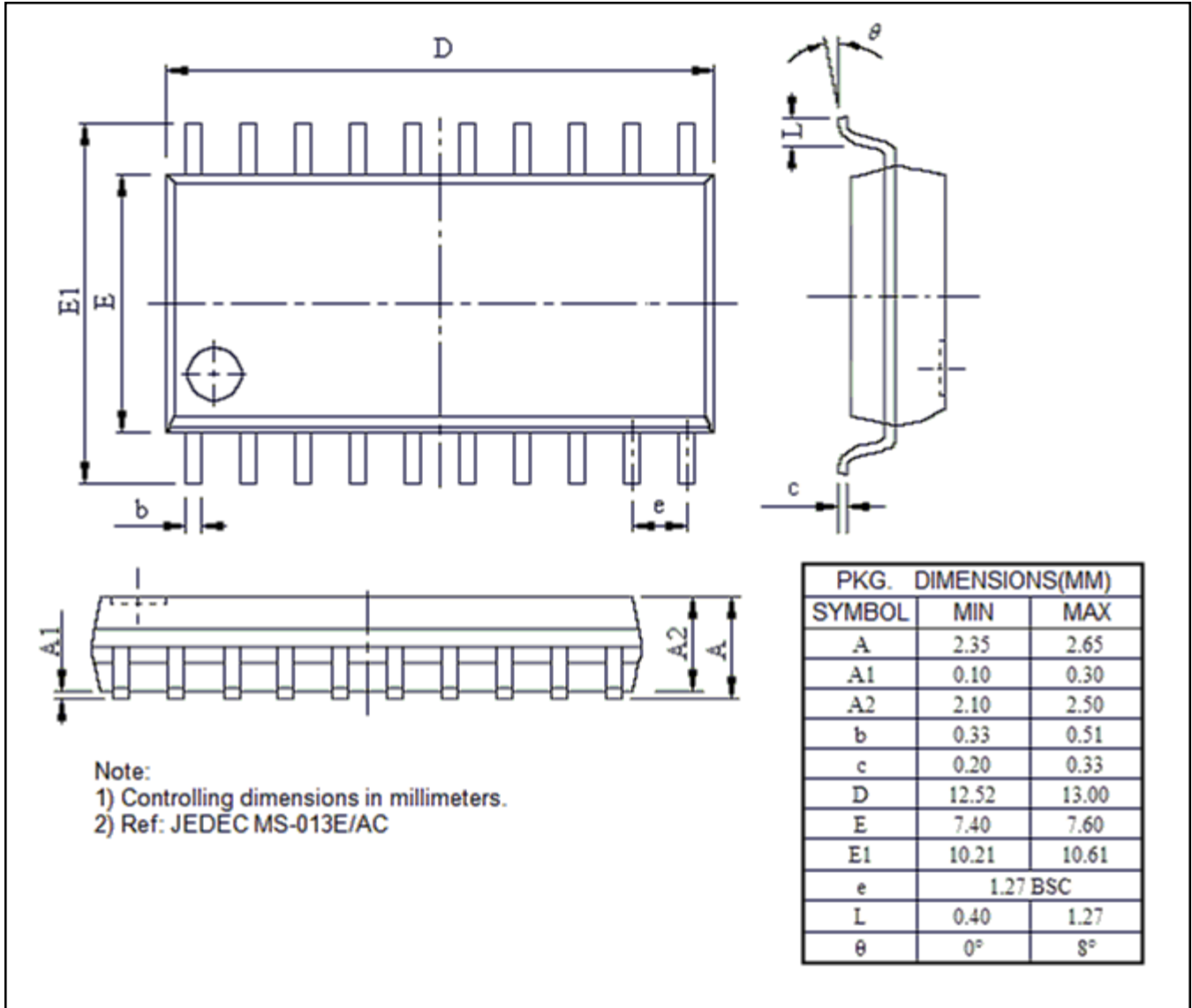


**Figure 4. Futaba-S3003 Servo Application Circuit of PT8A9961/9962/9963/9964**



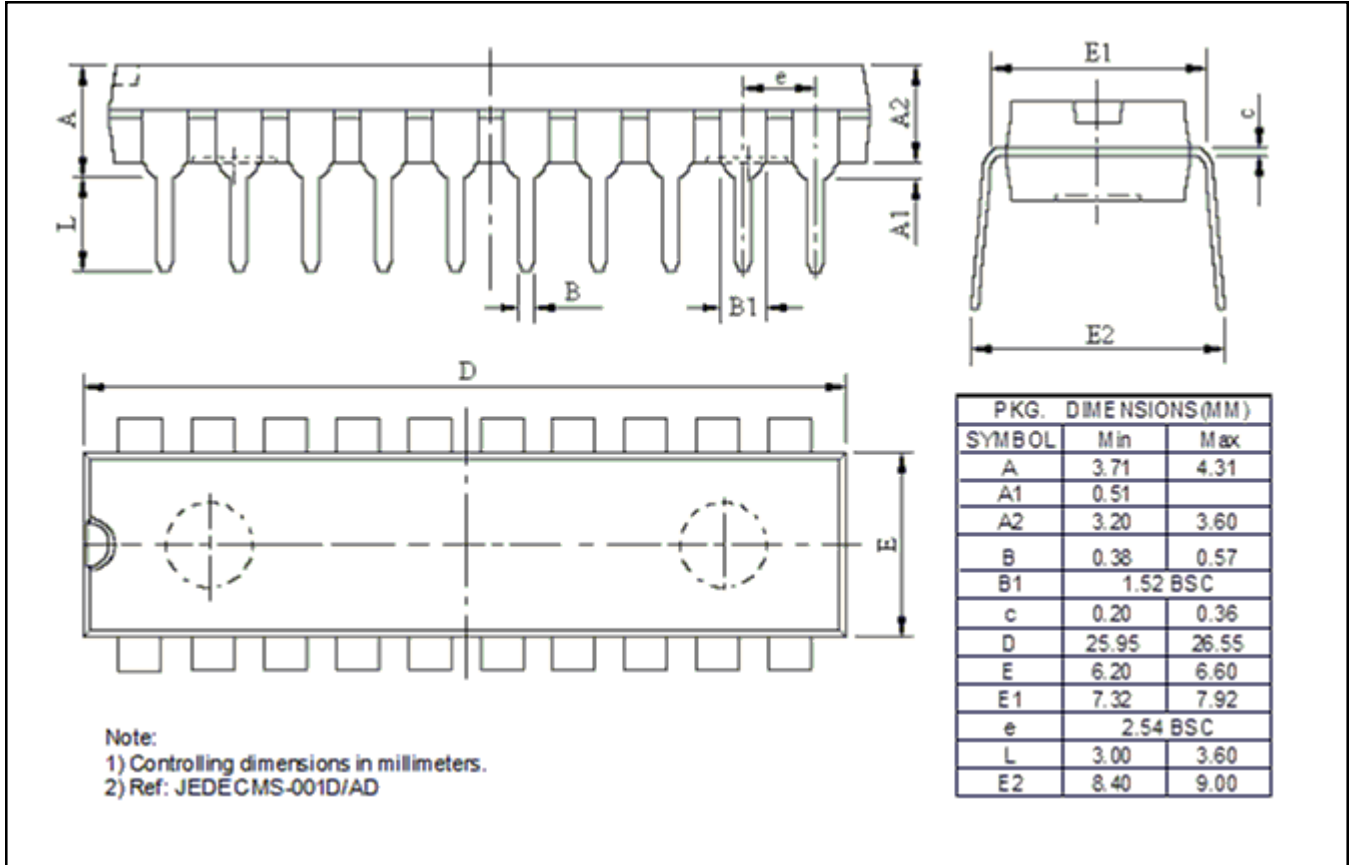
### Mechanical Information

20-pin SOIC

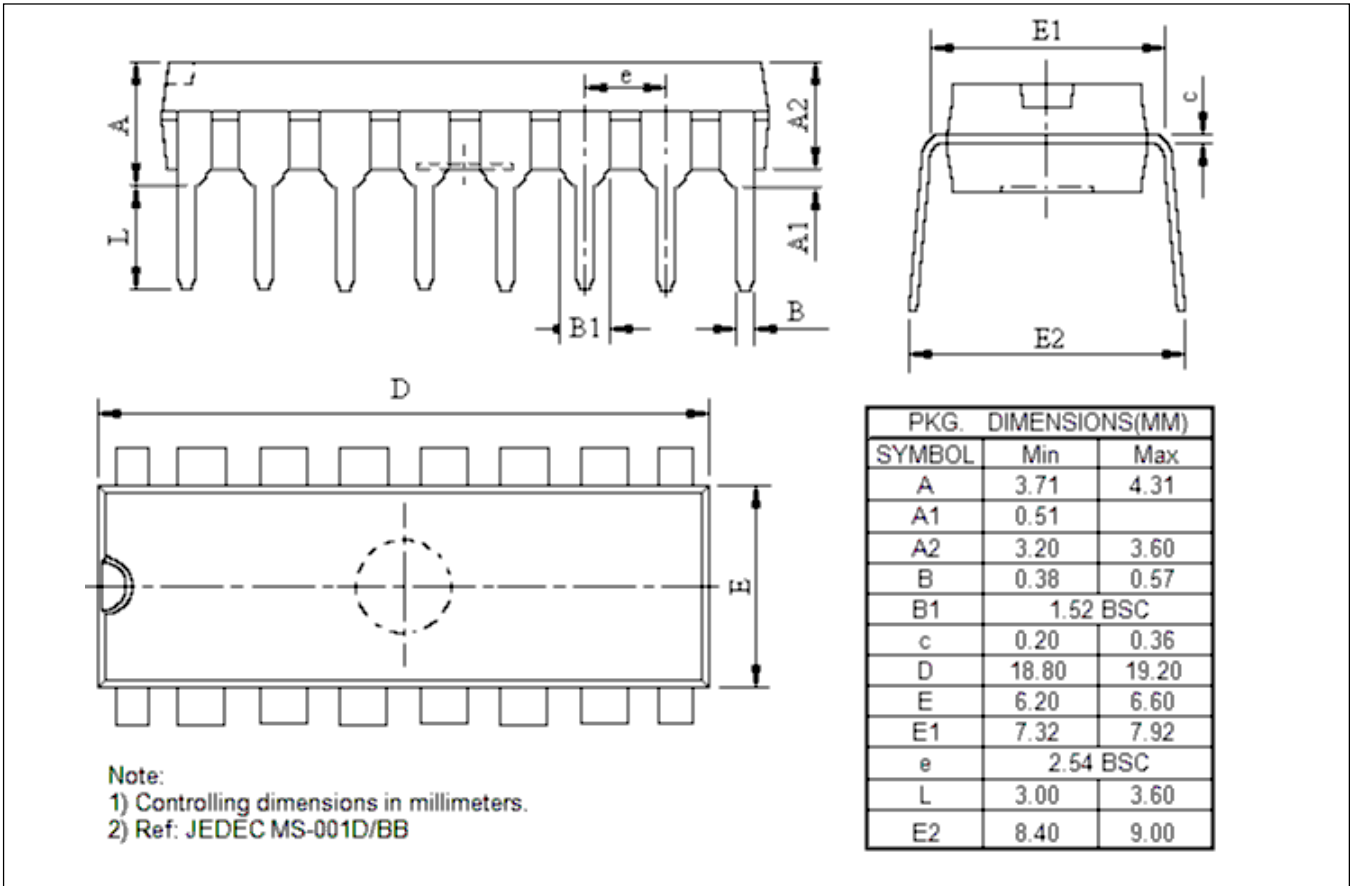




20-pin DIP



16-pin DIP



Pericom Semiconductor Corporation • 1-800-435-2336 • www.pericom.com

Pericom Technology Incorporation reserves the right to make changes to its products or specifications at any time, without notice, in order to improve design or performance and to supply the best possible product. Pericom Technology does not assume any responsibility for use of any circuitry described other than the circuitry embodied in Pericom Technology product. The company makes no representations that circuitry described herein is free from patent infringement or other rights, of Pericom.