



MICROCHIP

**MCP1810
Evaluation Board
User's Guide**

Note the following details of the code protection feature on Microchip devices:

- Microchip products meet the specification contained in their particular Microchip Data Sheet.
- Microchip believes that its family of products is one of the most secure families of its kind on the market today, when used in the intended manner and under normal conditions.
- There are dishonest and possibly illegal methods used to breach the code protection feature. All of these methods, to our knowledge, require using the Microchip products in a manner outside the operating specifications contained in Microchip's Data Sheets. Most likely, the person doing so is engaged in theft of intellectual property.
- Microchip is willing to work with the customer who is concerned about the integrity of their code.
- Neither Microchip nor any other semiconductor manufacturer can guarantee the security of their code. Code protection does not mean that we are guaranteeing the product as "unbreakable."

Code protection is constantly evolving. We at Microchip are committed to continuously improving the code protection features of our products. Attempts to break Microchip's code protection feature may be a violation of the Digital Millennium Copyright Act. If such acts allow unauthorized access to your software or other copyrighted work, you may have a right to sue for relief under that Act.

Information contained in this publication regarding device applications and the like is provided only for your convenience and may be superseded by updates. It is your responsibility to ensure that your application meets with your specifications. MICROCHIP MAKES NO REPRESENTATIONS OR WARRANTIES OF ANY KIND WHETHER EXPRESS OR IMPLIED, WRITTEN OR ORAL, STATUTORY OR OTHERWISE, RELATED TO THE INFORMATION, INCLUDING BUT NOT LIMITED TO ITS CONDITION, QUALITY, PERFORMANCE, MERCHANTABILITY OR FITNESS FOR PURPOSE. Microchip disclaims all liability arising from this information and its use. Use of Microchip devices in life support and/or safety applications is entirely at the buyer's risk, and the buyer agrees to defend, indemnify and hold harmless Microchip from any and all damages, claims, suits, or expenses resulting from such use. No licenses are conveyed, implicitly or otherwise, under any Microchip intellectual property rights unless otherwise stated.

Microchip received ISO/TS-16949:2009 certification for its worldwide headquarters, design and wafer fabrication facilities in Chandler and Tempe, Arizona; Gresham, Oregon and design centers in California and India. The Company's quality system processes and procedures are for its PIC[®] MCUs and dsPIC[®] DSCs, KEELOQ[®] code hopping devices, Serial EEPROMs, microperipherals, nonvolatile memory and analog products. In addition, Microchip's quality system for the design and manufacture of development systems is ISO 9001:2000 certified.

**QUALITY MANAGEMENT SYSTEM
CERTIFIED BY DNV
= ISO/TS 16949 =**

Trademarks

The Microchip name and logo, the Microchip logo, AnyRate, AVR, AVR logo, AVR Freaks, BeaconThings, BitCloud, CryptoMemory, CryptoRF, dsPIC, FlashFlex, flexPWR, Helder, JukeBlox, KEELOQ, KEELOQ logo, Klear, LANCheck, LINK MD, maXStylus, maXTouch, MediaLB, megaAVR, MOST, MOST logo, MPLAB, OptoLyzr, PIC, picoPower, PICSTART, PIC32 logo, Prochip Designer, QTouch, RightTouch, SAM-BA, SpyNIC, SST, SST Logo, SuperFlash, tinyAVR, UNI/O, and XMEGA are registered trademarks of Microchip Technology Incorporated in the U.S.A. and other countries.

ClockWorks, The Embedded Control Solutions Company, EtherSynch, Hyper Speed Control, HyperLight Load, IntelliMOS, mTouch, Precision Edge, and Quiet-Wire are registered trademarks of Microchip Technology Incorporated in the U.S.A.

Adjacent Key Suppression, AKS, Analog-for-the-Digital Age, Any Capacitor, AnyIn, AnyOut, BodyCom, chipKIT, chipKIT logo, CodeGuard, CryptoAuthentication, CryptoCompanion, CryptoController, dsPICDEM, dsPICDEM.net, Dynamic Average Matching, DAM, ECAN, EtherGREEN, In-Circuit Serial Programming, ICSP, Inter-Chip Connectivity, JitterBlocker, KlearNet, KlearNet logo, Mindi, MiWi, motorBench, MPASM, MPF, MPLAB Certified logo, MPLIB, MPLINK, MultiTRAK, NetDetach, Omniscient Code Generation, PICDEM, PICDEM.net, PICkit, PICtail, PureSilicon, QMatrix, RightTouch logo, REAL ICE, Ripple Blocker, SAM-ICE, Serial Quad I/O, SMART-I.S., SQI, SuperSwitcher, SuperSwitcher II, Total Endurance, TSHARC, USBCheck, VariSense, ViewSpan, WiperLock, Wireless DNA, and ZENA are trademarks of Microchip Technology Incorporated in the U.S.A. and other countries.

SQTP is a service mark of Microchip Technology Incorporated in the U.S.A.

Silicon Storage Technology is a registered trademark of Microchip Technology Inc. in other countries.

GestIC is a registered trademark of Microchip Technology Germany II GmbH & Co. KG, a subsidiary of Microchip Technology Inc., in other countries.

All other trademarks mentioned herein are property of their respective companies.

© 2017, Microchip Technology Incorporated, All Rights Reserved.

ISBN: 978-1-5224-1288-5

Object of Declaration: MCP1810 Evaluation Board

EU Declaration of Conformity

This declaration of conformity is issued by the manufacturer.

The development/evaluation tool is designed to be used for research and development in a laboratory environment. This development/evaluation tool is not a Finished Appliance, nor is it intended for incorporation into Finished Appliances that are made commercially available as single functional units to end users under EU EMC Directive 2004/108/EC and as supported by the European Commission's Guide for the EMC Directive 2004/108/EC (8th February 2010).

This development/evaluation tool complies with EU RoHS2 Directive 2011/65/EU.

This development/evaluation tool, when incorporating wireless and radio-telecom functionality, is in compliance with the essential requirement and other relevant provisions of the R&TTE Directive 1999/5/EC and the FCC rules as stated in the declaration of conformity provided in the module datasheet and the module product page available at www.microchip.com. For information regarding the exclusive, limited warranties applicable to Microchip products, please see Microchip's standard terms and conditions of sale, which are printed on our sales documentation and available at www.microchip.com.

Signed for and on behalf of Microchip Technology Inc. at Chandler, Arizona, USA.

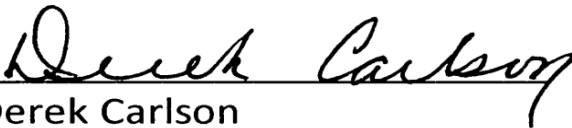
Derek Carlson

VP Development Tools

11-NOV-16
Date

DSTEMP

NOTES:



MCP1810 EVALUATION BOARD USER'S GUIDE

Table of Contents

Preface	7
Introduction.....	7
Document Layout	7
Conventions Used in this Guide	8
Recommended Reading.....	9
The Microchip Web Site	9
Customer Support	9
Document Revision History	9
Chapter 1. Product Overview	
1.1 Introduction	11
1.2 MCP1810 Short Overview	11
1.2.1 MCP1810 Features	12
1.3 MCP1810 Evaluation Board Description	12
1.3.1 MCP1810 Evaluation Board Features	12
1.4 MCP1810 Evaluation Board Kit Contents	12
Chapter 2. Installation and Operation	
2.1 Getting Started	13
2.1.1 Powering the MCP1810 Evaluation Board	13
2.1.2 Board Testing	13
Appendix A. Schematic and Layouts	
A.1 Introduction	15
A.2 Board – Schematic	16
A.3 Board – Top Silk	17
A.4 Board – Top Copper and Silk	18
A.5 Board – Top Copper	19
A.6 Board – Bottom Copper	20
A.7 Board – Bottom Copper and Silk	21
A.8 Board – Bottom Silk	22
Appendix B. Bill of Materials (BOM)	23
Worldwide Sales and Service	24

MCP1810 Evaluation Board User's Guide

NOTES:



MCP1810 EVALUATION BOARD USER'S GUIDE

Preface

NOTICE TO CUSTOMERS

All documentation becomes dated, and this manual is no exception. Microchip tools and documentation are constantly evolving to meet customer needs, so some actual dialogs and/or tool descriptions may differ from those in this document. Please refer to our web site (www.microchip.com) to obtain the latest documentation available.

Documents are identified with a “DS” number. This number is located on the bottom of each page, in front of the page number. The numbering convention for the DS number is “DSXXXXXXXXA”, where “XXXXXXXX” is the document number and “A” is the revision level of the document.

For the most up-to-date information on development tools, see the MPLAB® IDE online help. Select the Help menu, and then Topics, to open a list of available online help files.

INTRODUCTION

This chapter contains general information that will be useful to know before using the MCP1810 Evaluation Board. Items discussed in this chapter include:

- [Document Layout](#)
- [Conventions Used in this Guide](#)
- [Recommended Reading](#)
- [The Microchip Web Site](#)
- [Customer Support](#)
- [Document Revision History](#)

DOCUMENT LAYOUT

This document describes how to use the MCP1810 Evaluation Board as a development tool to emulate and debug firmware on a target board. The manual layout is as follows:

- **Chapter 1. “Product Overview”** – Important information about the MCP1810 Evaluation Board.
- **Chapter 2. “Installation and Operation”** – Includes instructions on installing and starting the Microchip Chip Manager application.
- **Appendix A. “Schematic and Layouts”** – Shows the schematic and layout diagrams for the MCP1810 Evaluation Board.
- **Appendix B. “Bill of Materials (BOM)”** – Lists the parts used to build the MCP1810 Evaluation Board.

MCP1810 Evaluation Board User's Guide

CONVENTIONS USED IN THIS GUIDE

This manual uses the following documentation conventions:

DOCUMENTATION CONVENTIONS

Description	Represents	Examples
Arial font:		
Italic characters	Referenced books	<i>MPLAB® IDE User's Guide</i>
	Emphasized text	...is the <i>only</i> compiler...
Initial caps	A window	the Output window
	A dialog	the Settings dialog
	A menu selection	select Enable Programmer
Quotes	A field name in a window or dialog	"Save project before build"
Underlined, italic text with right angle bracket	A menu path	<u><i>File>Save</i></u>
Bold characters	A dialog button	Click OK
	A tab	Click the Power tab
N'Rnnnn	A number in verilog format, where N is the total number of digits, R is the radix and n is a digit.	4'b0010, 2'hF1
Text in angle brackets < >	A key on the keyboard	Press <Enter>, <F1>
Courier New font:		
Plain Courier New	Sample source code	#define START
	Filenames	autoexec.bat
	File paths	c:\mcc18\h
	Keywords	_asm, _endasm, static
	Command-line options	-Opa+, -Opa-
	Bit values	0, 1
	Constants	0xFF, 'A'
Italic Courier New	A variable argument	<i>file.o</i> , where <i>file</i> can be any valid filename
Square brackets []	Optional arguments	mcc18 [options] <i>file</i> [options]
Curly brackets and pipe character: { }	Choice of mutually exclusive arguments; an OR selection	errorlevel {0 1}
Ellipses...	Replaces repeated text	var_name [, var_name...]
	Represents code supplied by user	void main (void) { ... }

RECOMMENDED READING

This user's guide describes how to use the MCP1810 Evaluation Board. Other useful documents are listed below. The following Microchip document is available and recommended as a supplemental reference resource:

MCP1810 Data Sheet – “MCP1810 Ultra-Low Quiescent Current LDO Regulator” (DS20005623)

THE MICROCHIP WEB SITE

Microchip provides online support via our web site at www.microchip.com. This web site is used as a means to make files and information easily available to customers. Accessible by using your favorite Internet browser, the web site contains the following information:

- **Product Support** – Data sheets and errata, application notes and sample programs, design resources, user's guides and hardware support documents, latest software releases and archived software
- **General Technical Support** – Frequently Asked Questions (FAQs), technical support requests, online discussion groups, Microchip consultant program member listing
- **Business of Microchip** – Product selector and ordering guides, latest Microchip press releases, listing of seminars and events, listings of Microchip sales offices, distributors and factory representatives

CUSTOMER SUPPORT

Users of Microchip products can receive assistance through several channels:

- Distributor or Representative
- Local Sales Office
- Field Application Engineer (FAE)
- Technical Support

Customers should contact their distributor, representative or field application engineer (FAE) for support. Local sales offices are also available to help customers. A listing of sales offices and locations is included in the back of this document.

Technical support is available through the web site at:
<http://www.microchip.com/support>.

DOCUMENT REVISION HISTORY

Revision A (January 2017)

- Initial Release of this Document.

MCP1810 Evaluation Board User's Guide

NOTES:

Chapter 1. Product Overview

1.1 INTRODUCTION

This chapter covers a short overview of the MCP1810 Evaluation Board and includes the following topics:

- [MCP1810 Short Overview](#)
- [MCP1810 Evaluation Board Description](#)
- [MCP1810 Evaluation Board Kit Contents](#)

1.2 MCP1810 SHORT OVERVIEW

The MCP1810 Low Dropout (LDO) linear regulator can supply a 150 mA load (for output voltages, $V_R \leq 3.5V$) or 100 mA load if the output voltage is higher than 3.5V. The MCP1810 will maintain a 20 nA quiescent current if no load is present. Even more significant, when in shutdown, the MCP1810 draws a 1 nA current (typical).

MCP1810 comes in six standard fixed output voltage versions: 1.2V, 1.8V, 2.5V, 3.0V, 3.3V and 4.2V.

The MCP1810 device's characteristics of low output voltage, and up to 150 mA of output current, make the MCP1810 a good candidate for ultra long life LDO applications that require high output current to be combined with ultra low-power consumption during the Sleep state.

The LDO is stable with output ceramic capacitors, which inherently provide lower output noise and reduce the size of the whole regulator solution. MCP1810 is in regulation with only a 1 μF output capacitor; however, a 2.2 μF capacitor is recommended for optimum performance.

The MCP1810 device's ultra low quiescent current and shutdown current allow it to be paired with other ultra low-current consumption devices, such as Microchip's XLP technology devices, for a complete ultra low-power solution.

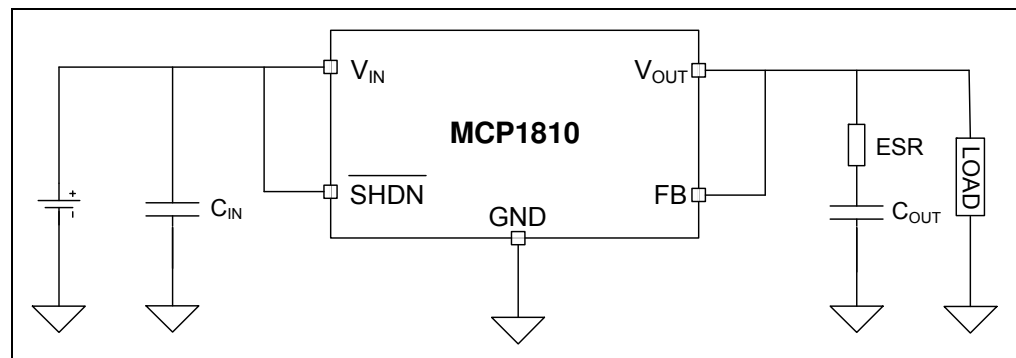

FIGURE 1-1: MCP1810 Typical Application

MCP1810 Evaluation Board User's Guide

1.2.1 MCP1810 Features

- Ultra Low Quiescent Current: 20 nA (typical)
- Ultra Low Shutdown Supply Current: 1 nA (typical)
- 150 mA Output Current Capability for $V_R \leq 3.5V$ (where V_R is the regulated output voltage)
- 100 mA Output Current Capability for $V_R > 3.5V$
- Input Operating Voltages Range: 2.5V to 5.5V
- Standard Output Voltages (V_R): 1.2V, 1.8V, 2.5V, 3.0V, 3.3V, 4.2V
- Dropout Voltage (V_{DROP}): 380 mV @ 150 mA
- Stable with 1.0 μF Ceramic Output Capacitor with X7R or X5R Dielectric
- Overcurrent Protection
- Space-Saving, 8-Lead Very Thin Plastic Dual Flat No Lead Package, 2 x 2 mm Body VDFN

1.3 MCP1810 EVALUATION BOARD DESCRIPTION

The MCP1810 Evaluation Board operates with an input supply voltage range of 2.5V, up to 5.5V, and outputs a fixed regulated voltage according to the MCP1810 rating.

The board comes with test points that allow for easy integration into a test setup. The MCP1810 Evaluation Board also has an unpopulated part and capacitors in order to allow the customer to experiment with other voltage options and/or capacitor configurations.

1.3.1 MCP1810 Evaluation Board Features

The MCP1810 Evaluation Board was developed to showcase the MCP1810 device's performances over a wide input voltage range and load current range. The board comes with a MCP1810 fixed 3.3V output voltage, and access is given to the input and output pins, the \overline{SHDN} pin and Ground pins. The MCP1810 is powered on when the voltage on the enable pin is at least 70% of V_{IN} and is turned off when the voltage on the \overline{SHDN} pin drops below 30% of V_{IN} .

The user can experiment with different ESR values of the output capacitor by replacing the 0Ω series resistor. Also, the MCP1810 Evaluation Board comes with an unpopulated MCP1810 and capacitor footprints, which allow the user to experiment with different output voltage options for the MCP1810 and output capacitor sizes.

1.4 MCP1810 EVALUATION BOARD KIT CONTENTS

The MCP1810 Evaluation Board kit includes the following items:

- MCP1810 Evaluation Board (ADM00808)
- Important Information Sheet

Chapter 2. Installation and Operation

2.1 GETTING STARTED

The MCP1810 Evaluation Board is fully assembled and tested to evaluate and demonstrate the characteristics of the MCP1810.

2.1.1 Powering the MCP1810 Evaluation Board

Apply the positive input voltage to the test point marked as V_{IN} and the return ground connection to the test point marked as GND. The input voltage needs to be a minimum of 4.1V in order to test the 3.3V output voltage option ($V_{IN} = V_R + 0.8V$). DO NOT APPLY a voltage higher than 5.5V or you may damage the part. The MCP1810 will be on, but as a default option, it can be turned on with a pull-up resistor to V_{IN} . The part can be shut down by placing a jumper on the SHDN connector. Note that current will flow through the resistor when trying to measure the quiescent current; that being said, it is advisable to remove the pull-up resistor and place a wire or zero ohm resistor in its place if you're attempting to measure the quiescent or shutdown current.

The output current capabilities can be tested using resistive loads or an electronic load set to constant resistance. The positive terminal of the load must be connected to V_{OUT} and the negative terminal to the corresponding test point marked with GND.

Note: Note that an electronic load will have the tendency to sink a current when the output of the LDO is 0V.
--

2.1.2 Board Testing

2.1.2.1 TESTING THE DEFAULT CONFIGURATION – TOP SIDE OF THE BOARD

To test the board, follow these steps:

1. Apply the appropriate input voltage, $V_{IN} = 5V$
2. Use a multimeter and measure the input voltage and output voltage. V_R should be 3.3V.
3. Connect a resistor with 66Ω to the V_{OUT} and GND terminal as a load and test V_R ; it should be 3.3V.
4. Connect a jumper on the $\overline{\text{SHDN}}$ header. Test V_R ; it should be 0V.
5. Remove the jumper from the $\overline{\text{SHDN}}$ header; V_R should be 3.3V.

By adjusting the input voltage or load, while still maintaining nominal operating conditions, the LDO will remain in regulation.

MCP1810 Evaluation Board User's Guide

2.1.2.2 TESTING A CUSTOM CONFIGURATION – BOTTOM SIDE OF THE BOARD

This area can be populated with a different MCP1810 voltage and it allows the user to use different options for the output capacitor. Tantalum capacitors in packages compatible with the B style case or lower can be used.

Also, the access to the enable pin is provided via the $\overline{\text{SHDN}}$ test point.

After soldering the part and capacitors, follow Steps 1 to 4 from [Section 2.1.2.1 “Testing the Default Configuration – Top Side of the Board”](#) to evaluate the performance of the part.

In order to test the shutdown functionality, a jumper wire is required to connect the $\overline{\text{SHDN}}$ pin to a ground terminal.



MCP1810 EVALUATION BOARD USER'S GUIDE

Appendix A. Schematic and Layouts

A.1 INTRODUCTION

This appendix contains the following schematics and layouts for the MCP1810 Evaluation Board:

- [Board – Schematic](#)
- [Board – Top Silk](#)
- [Board – Top Copper and Silk](#)
- [Board – Top Copper](#)
- [Board – Bottom Copper](#)
- [Board – Bottom Copper and Silk](#)
- [Board – Bottom Silk](#)

MCP1810 Evaluation Board User's Guide

A.2 BOARD – SCHEMATIC

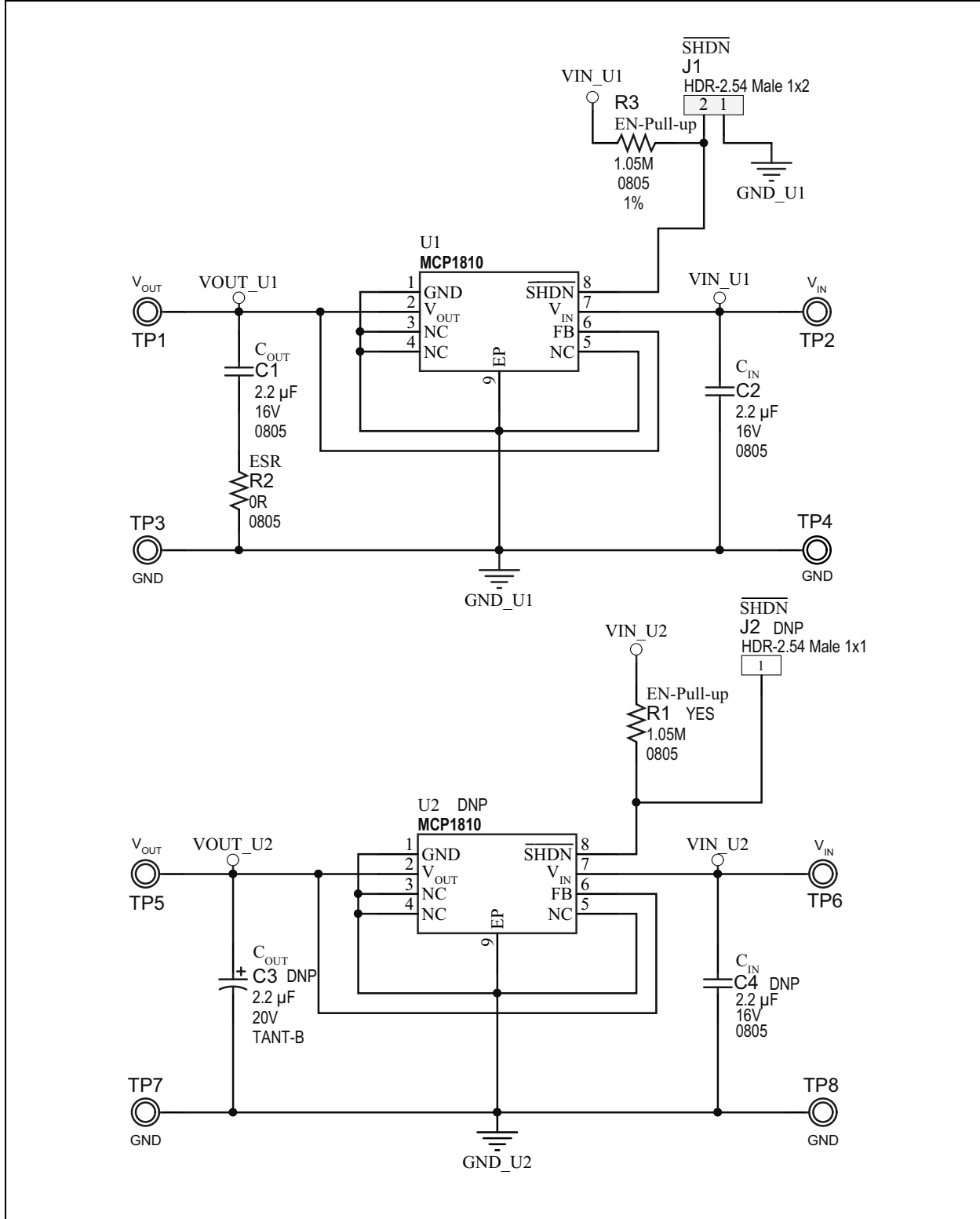

A.3 BOARD – TOP SILK

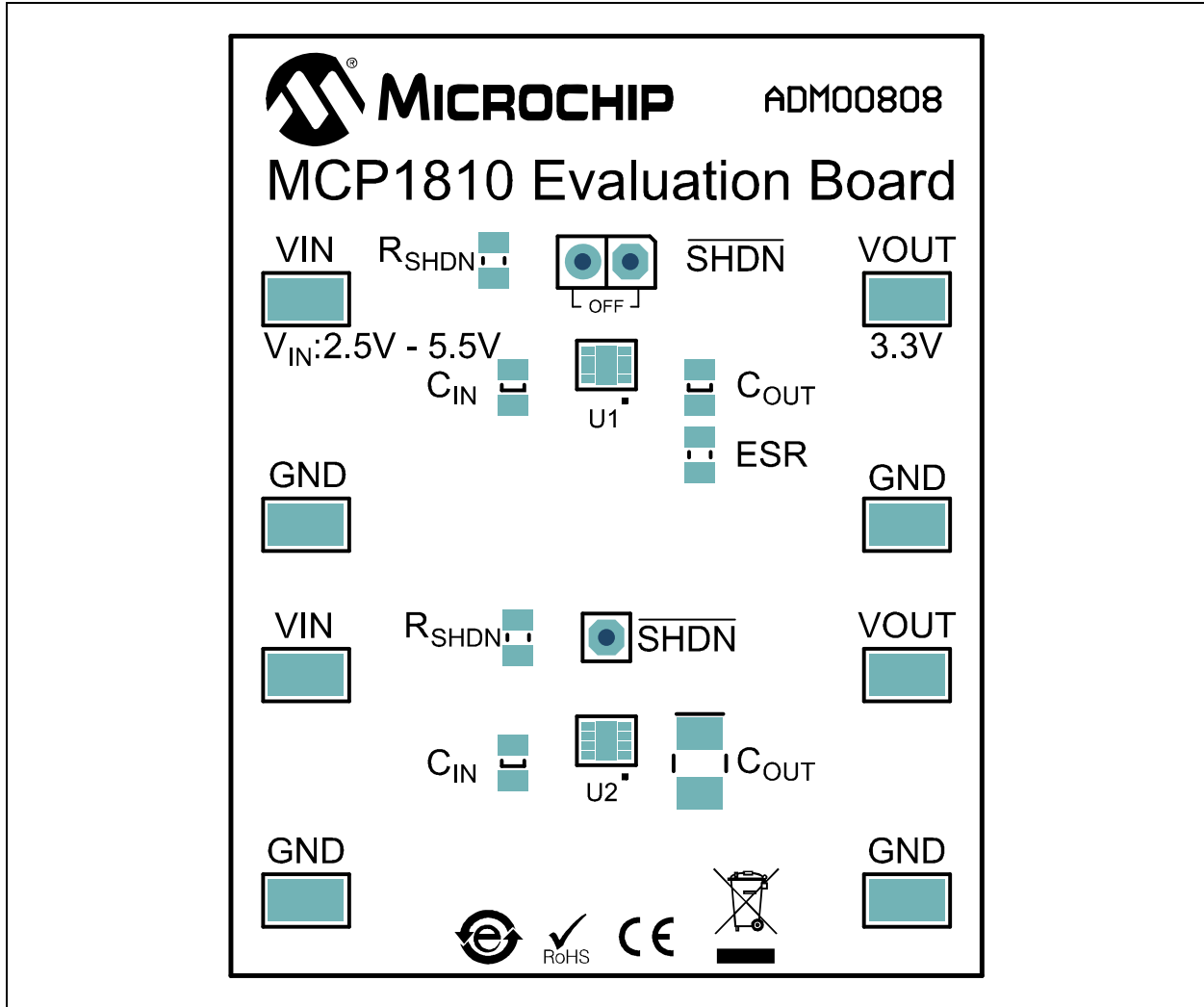

MCP1810 Evaluation Board User's Guide

A.4 BOARD – TOP COPPER AND SILK

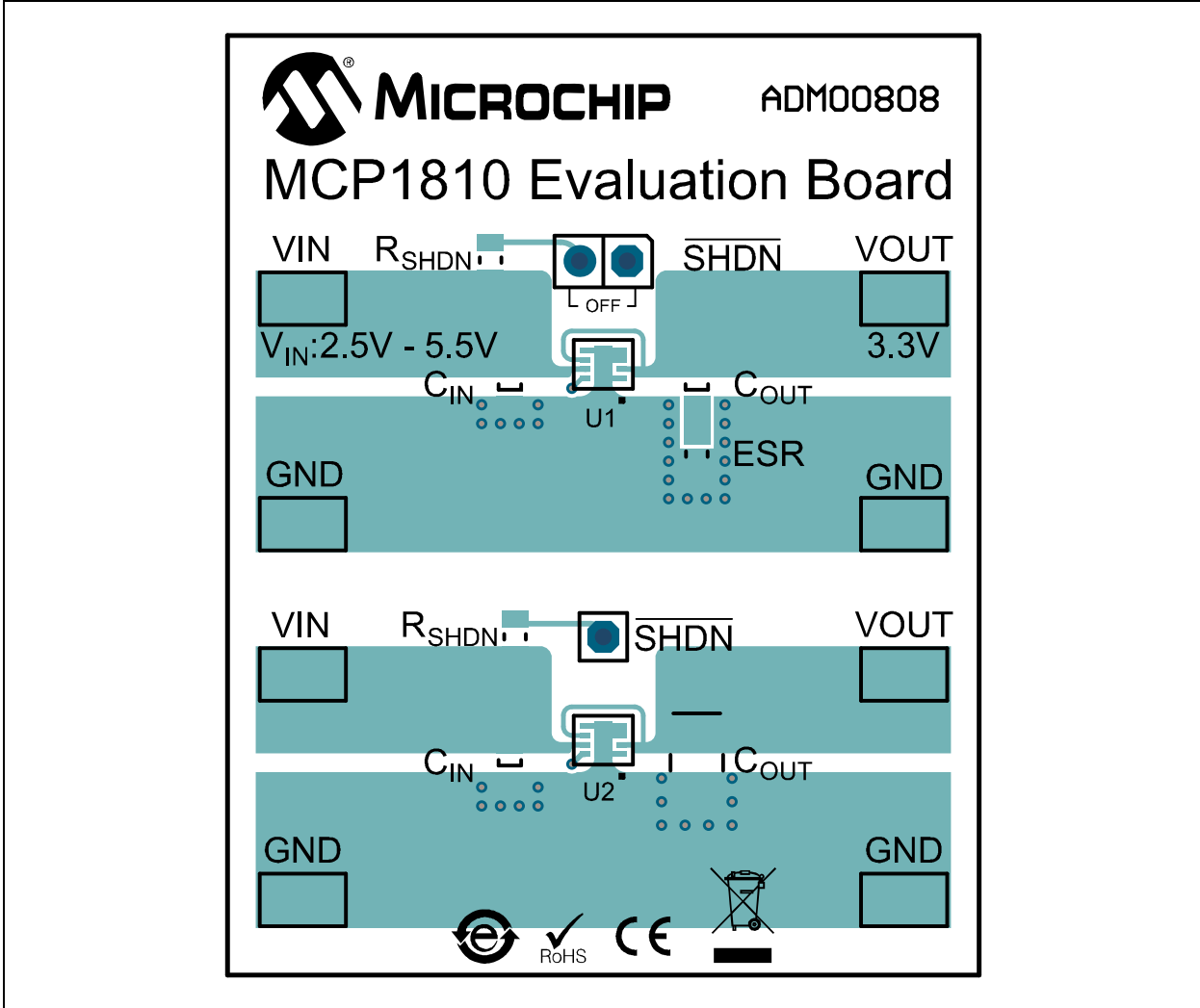

A.5 BOARD – TOP COPPER

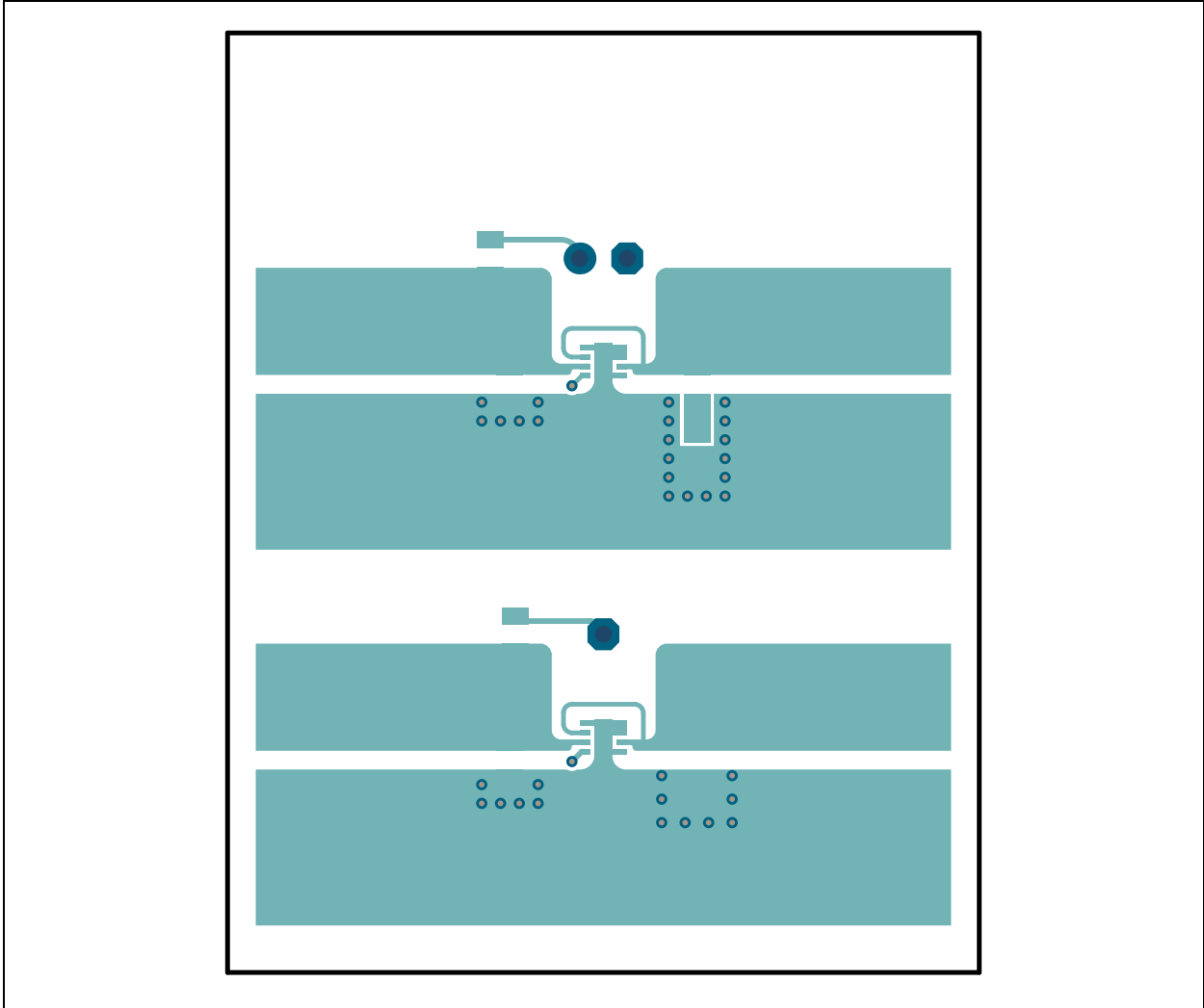

MCP1810 Evaluation Board User's Guide

A.6 BOARD – BOTTOM COPPER

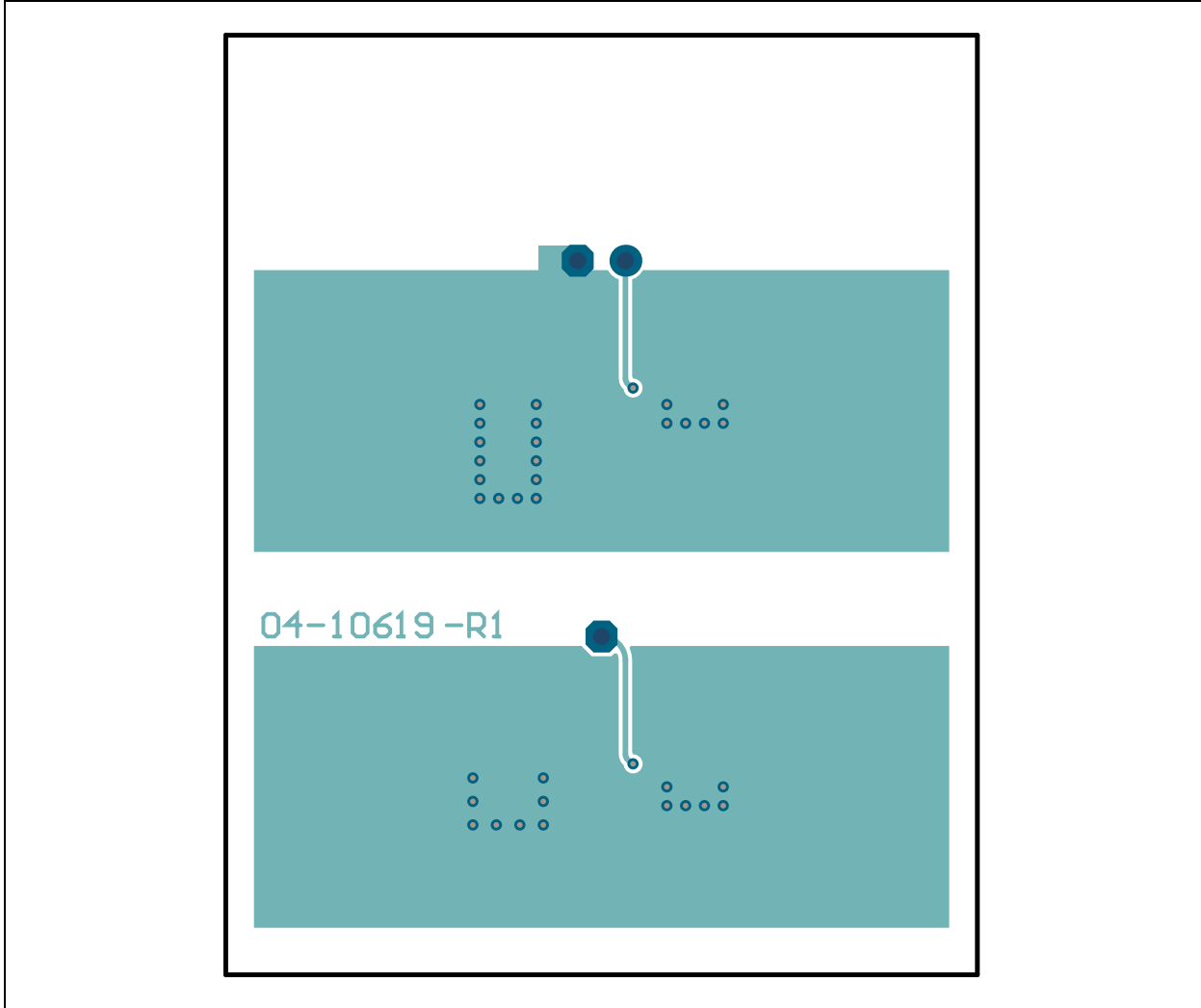

A.7 BOARD – BOTTOM COPPER AND SILK

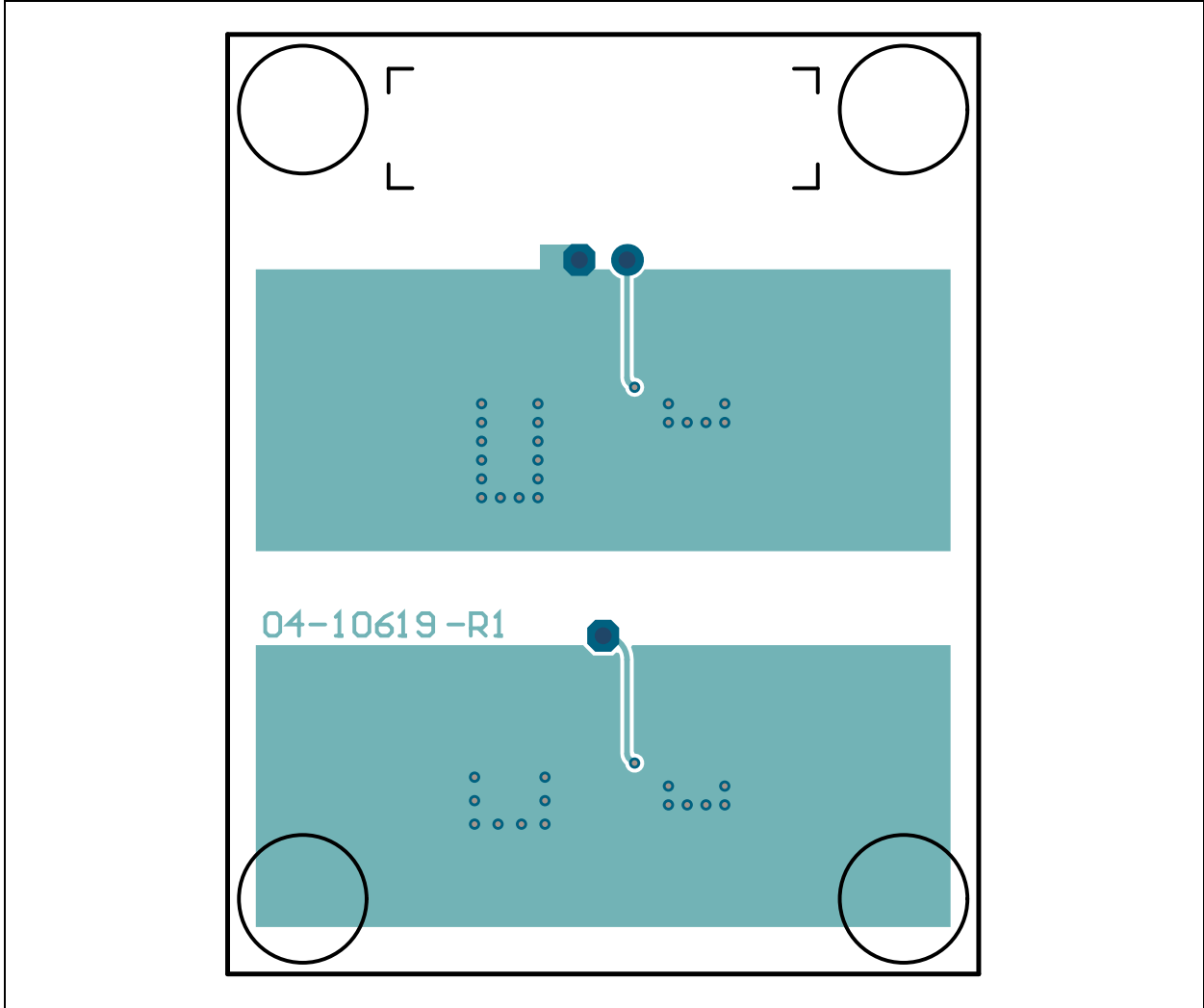

MCP1810 Evaluation Board User's Guide

A.8 BOARD – BOTTOM SILK

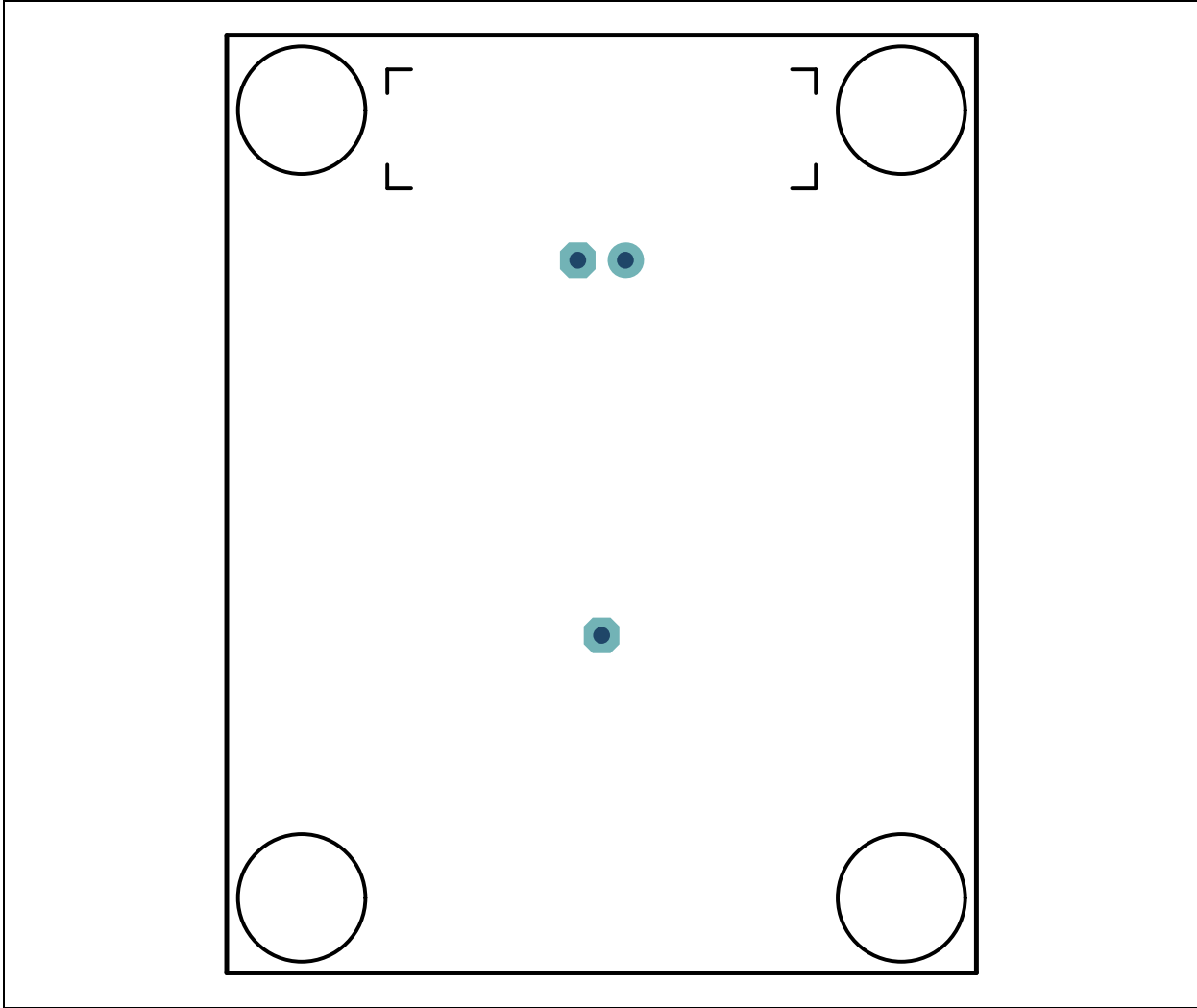



MCP1810 EVALUATION BOARD USER'S GUIDE

Appendix B. Bill of Materials (BOM)

TABLE B-1: BILL OF MATERIALS (BOM)⁽¹⁾

Qty.	Reference	Description	Manufacturer	Part Number
2	C1, C2	Capacitor Ceramic, 2.2 μ F, 16V, 10%, X7R, SMD, 0805	TDK Corporation	C2012X7R1C225K125AB
1	J1	Connector Header – 2.54 Male, 1x2, Tin, 6.75 MH TH, Vertical	Molex [®]	0901200122
4	PAD1, PAD2, PAD3, PAD4	Mechanical HW, Rubber Pad, Hemisphere, D6.4 H1.9, Clear	3M	SJ5382
1	PCB	Printed Circuit Board – MCP1810 Evaluation Board	Microchip Technology Inc.	04-10619
2	R1, R3	Resistor TKF, 1.05M, 1%, 1/8W, SMD, 0805	Yageo Corporation	RC0805FR-071M05L
1	R2	Resistor TKF, 0R, 1/8W, SMD, 0805	Panasonic [®]	ERJ-6GEY0R00V
8	TP1, TP2, TP3, TP4, TP5, TP6, TP7, TP8	Connector TP, TAB, Silver Mini, 3.8x2.03, SMD	Keystone Electronics Corp.	5019
1	U1	Microchip Analog LDO, 3.3V, MCP1810T-33I VDFN-8	Microchip Technology Inc.	MCP1810T-33I/J8A

Note 1: The components listed in this Bill of Materials are representative of the PCB assembly. The released BOM used in manufacturing uses all RoHS-compliant components.



MICROCHIP

Worldwide Sales and Service

AMERICAS

Corporate Office

2355 West Chandler Blvd.
Chandler, AZ 85224-6199
Tel: 480-792-7200
Fax: 480-792-7277
Technical Support:
<http://www.microchip.com/support>

Web Address:

www.microchip.com

Atlanta

Duluth, GA
Tel: 678-957-9614
Fax: 678-957-1455

Austin, TX

Tel: 512-257-3370

Boston

Westborough, MA
Tel: 774-760-0087
Fax: 774-760-0088

Chicago

Itasca, IL
Tel: 630-285-0071
Fax: 630-285-0075

Dallas

Addison, TX
Tel: 972-818-7423
Fax: 972-818-2924

Detroit

Novi, MI
Tel: 248-848-4000

Houston, TX

Tel: 281-894-5983

Indianapolis

Noblesville, IN
Tel: 317-773-8323
Fax: 317-773-5453
Tel: 317-536-2380

Los Angeles

Mission Viejo, CA
Tel: 949-462-9523
Fax: 949-462-9608
Tel: 951-273-7800

Raleigh, NC

Tel: 919-844-7510

New York, NY

Tel: 631-435-6000

San Jose, CA

Tel: 408-735-9110
Tel: 408-436-4270

Canada - Toronto

Tel: 905-695-1980
Fax: 905-695-2078

ASIA/PACIFIC

Asia Pacific Office

Suites 3707-14, 37th Floor
Tower 6, The Gateway
Harbour City, Kowloon

Hong Kong

Tel: 852-2943-5100
Fax: 852-2401-3431

Australia - Sydney

Tel: 61-2-9868-6733
Fax: 61-2-9868-6755

China - Beijing

Tel: 86-10-8569-7000
Fax: 86-10-8528-2104

China - Chengdu

Tel: 86-28-8665-5511
Fax: 86-28-8665-7889

China - Chongqing

Tel: 86-23-8980-9588
Fax: 86-23-8980-9500

China - Dongguan

Tel: 86-769-8702-9880

China - Guangzhou

Tel: 86-20-8755-8029

China - Hangzhou

Tel: 86-571-8792-8115
Fax: 86-571-8792-8116

China - Hong Kong SAR

Tel: 852-2943-5100
Fax: 852-2401-3431

China - Nanjing

Tel: 86-25-8473-2460
Fax: 86-25-8473-2470

China - Qingdao

Tel: 86-532-8502-7355
Fax: 86-532-8502-7205

China - Shanghai

Tel: 86-21-3326-8000
Fax: 86-21-3326-8021

China - Shenyang

Tel: 86-24-2334-2829
Fax: 86-24-2334-2393

China - Shenzhen

Tel: 86-755-8864-2200
Fax: 86-755-8203-1760

China - Wuhan

Tel: 86-27-5980-5300
Fax: 86-27-5980-5118

China - Xian

Tel: 86-29-8833-7252
Fax: 86-29-8833-7256

ASIA/PACIFIC

China - Xiamen

Tel: 86-592-2388138
Fax: 86-592-2388130

China - Zhuhai

Tel: 86-756-3210040
Fax: 86-756-3210049

India - Bangalore

Tel: 91-80-3090-4444
Fax: 91-80-3090-4123

India - New Delhi

Tel: 91-11-4160-8631
Fax: 91-11-4160-8632

India - Pune

Tel: 91-20-3019-1500

Japan - Osaka

Tel: 81-6-6152-7160
Fax: 81-6-6152-9310

Japan - Tokyo

Tel: 81-3-6880-3770
Fax: 81-3-6880-3771

Korea - Daegu

Tel: 82-53-744-4301
Fax: 82-53-744-4302

Korea - Seoul

Tel: 82-2-554-7200
Fax: 82-2-558-5932 or
82-2-558-5934

Malaysia - Kuala Lumpur

Tel: 60-3-6201-9857
Fax: 60-3-6201-9859

Malaysia - Penang

Tel: 60-4-227-8870
Fax: 60-4-227-4068

Philippines - Manila

Tel: 63-2-634-9065
Fax: 63-2-634-9069

Singapore

Tel: 65-6334-8870
Fax: 65-6334-8850

Taiwan - Hsin Chu

Tel: 886-3-5778-366
Fax: 886-3-5770-955

Taiwan - Kaohsiung

Tel: 886-7-213-7830

Taiwan - Taipei

Tel: 886-2-2508-8600
Fax: 886-2-2508-0102

Thailand - Bangkok

Tel: 66-2-694-1351
Fax: 66-2-694-1350

EUROPE

Austria - Wels

Tel: 43-7242-2244-39
Fax: 43-7242-2244-393

Denmark - Copenhagen

Tel: 45-4450-2828
Fax: 45-4485-2829

Finland - Espoo

Tel: 358-9-4520-820

France - Paris

Tel: 33-1-69-53-63-20
Fax: 33-1-69-30-90-79

France - Saint Cloud

Tel: 33-1-30-60-70-00

Germany - Garching

Tel: 49-8931-9700

Germany - Haan

Tel: 49-2129-3766400

Germany - Heilbronn

Tel: 49-7131-67-3636

Germany - Karlsruhe

Tel: 49-721-625370

Germany - Munich

Tel: 49-89-627-144-0
Fax: 49-89-627-144-44

Germany - Rosenheim

Tel: 49-8031-354-560

Israel - Ra'anana

Tel: 972-9-744-7705

Italy - Milan

Tel: 39-0331-742611
Fax: 39-0331-466781

Italy - Padova

Tel: 39-049-7625286

Netherlands - Drunen

Tel: 31-416-690399
Fax: 31-416-690340

Norway - Trondheim

Tel: 47-7289-7561

Poland - Warsaw

Tel: 48-22-3325737

Romania - Bucharest

Tel: 40-21-407-87-50

Spain - Madrid

Tel: 34-91-708-08-90
Fax: 34-91-708-08-91

Sweden - Gothenberg

Tel: 46-31-704-60-40

Sweden - Stockholm

Tel: 46-8-5090-4654

UK - Wokingham

Tel: 44-118-921-5800
Fax: 44-118-921-5820