

10 9 8 7 6 5 4 3 2 1

F

E

D

C

B

A

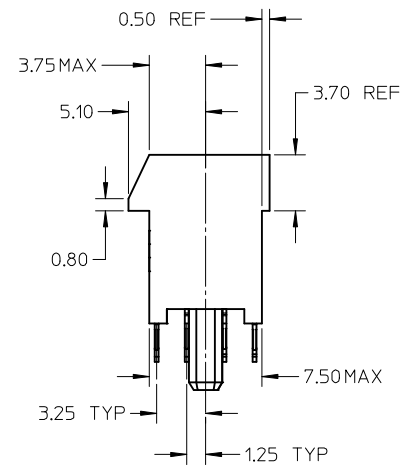
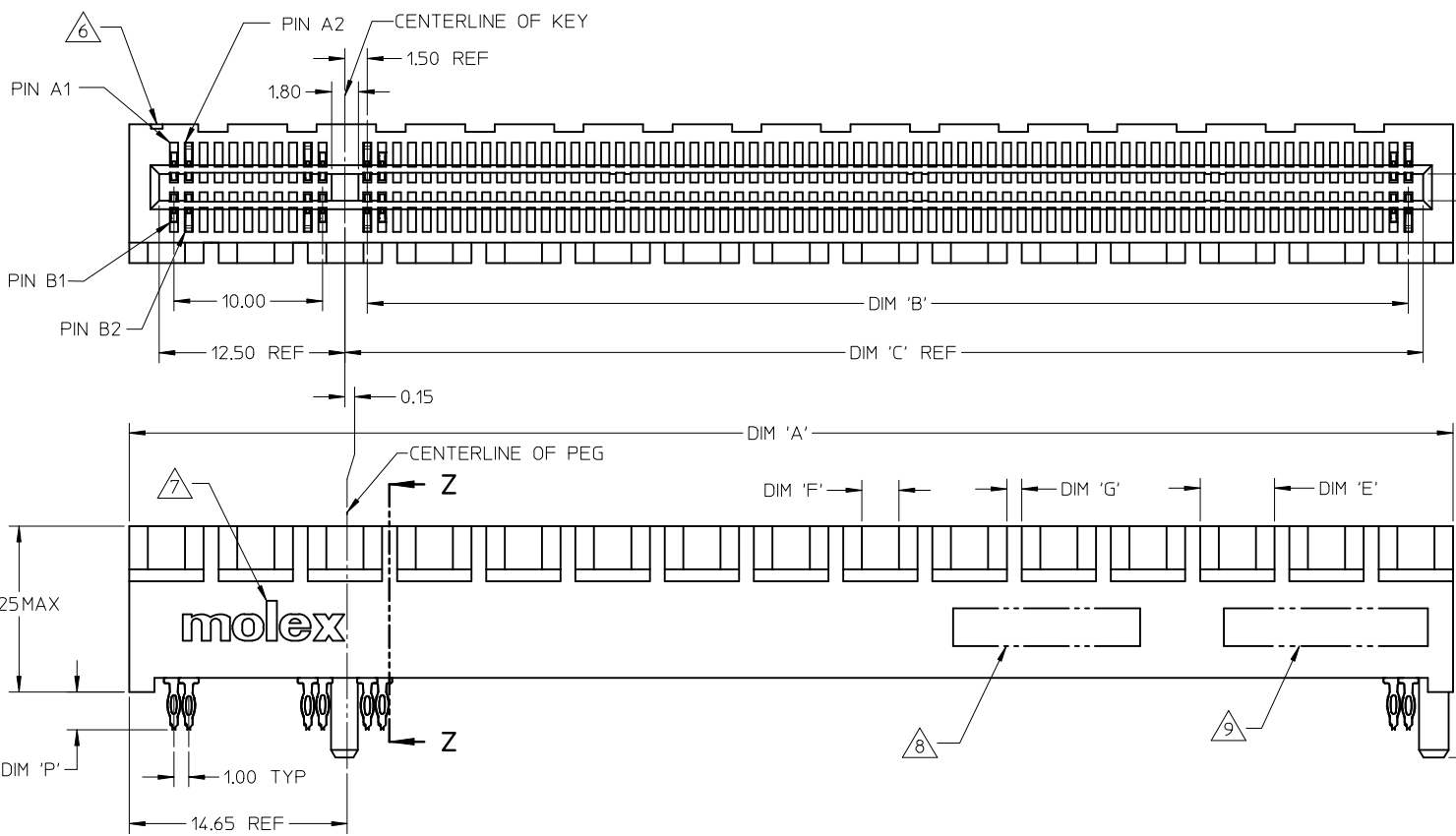

- NOTES :
- 1.MATERIALS :
HOUSING - HIGH TEMP. NYLON, GLASS FILLED, UL 94-V0, COLOUR BLACK.
TERMINAL - COPPER ALLOY.
 - 2.PLATING :
CONTACT AREA - SEE TABLE.
SOLDERTAIL - SEE TABLE.
 - 3.CARD SLOT ACCEPTS 1.57 ± 0.13MM MODULE THICKNESS.
(MEASURED ACROSS PADS)
 - 4.REFER TO PRODUCT SPECIFICATION, PS-78028-001 FOR PERFORMANCE SPECIFICATION.
 - 5.PRODUCT SHALL BE PACKED IN TRAY - REFER TO SHEET 5.

- △6 PIN #1 IDENTIFIER.
- △7 MOLEX LOGO.
- △8 DATE CODE (YYDDD).
- △9 PART NO. (78028-XXXX).
- 10.TOOLING STATUS - SEE TABLE

REVISED EC NO: S2009-0427 DRWN:VINSINHUANG 2008/12/10 CHKD:JESSIECHUA 2008/12/10 APPR:MAGESHKN 2008/12/11	DESCRIPTION C2	QUALITY SYMBOLS	GENERAL TOLERANCES (UNLESS SPECIFIED)	DIMENSION STYLE	SCALE	DESIGN UNITS	THIRD ANGLE PROJECTION	
		▼=0 □=0	mm INCH 4 PLACES ± --- ± --- 3 PLACES ± --- ± --- 2 PLACES ± 0.15 ± --- 1 PLACE ± --- ± --- ANGULAR ± 1 °	MM ONLY	NTS	METRIC		
				DRAWN BY: JTAN DATE: 2005/07/01 CHECKED BY: SRRAMESH DATE: 2005/10/10 APPROVED BY: GGLEE DATE: 2005/10/10 MATERIAL NO.	TITLE	PCI EXPRESS EDGE CARD CONNECTOR, PRESS-FIT		
				DRAFT WHERE APPLICABLE MUST REMAIN WITHIN DIMENSIONS	SEE TABLE	MOLEX INCORPORATED DOCUMENT NO. SD-78028-001 SHEET NO. 1 OF 8		
				SIZE	THIS DRAWING CONTAINS INFORMATION THAT IS PROPRIETARY TO MOLEX INCORPORATED AND SHOULD NOT BE USED WITHOUT WRITTEN PERMISSION			

9 8 7 6 5 4 3 2 1

10 9 8 7 6 5 4 3 2 1

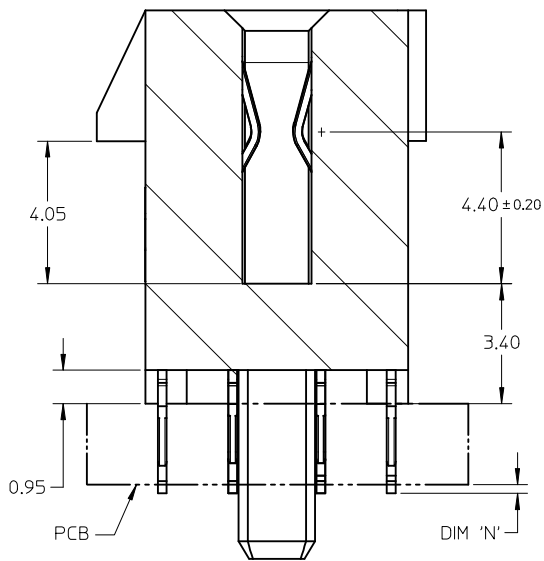
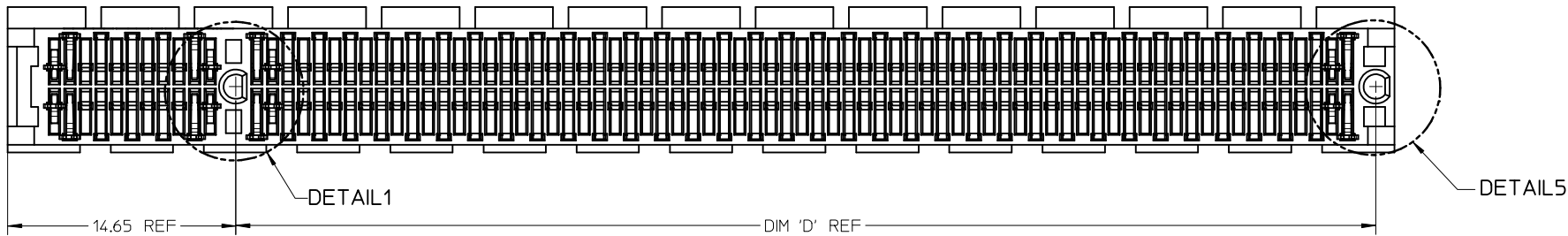

SECTION Z-Z

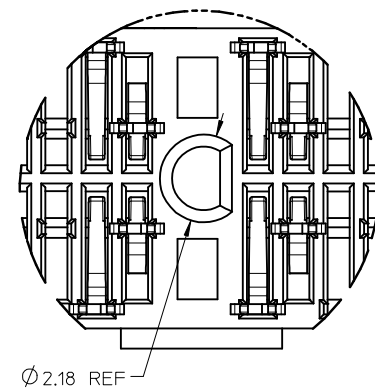
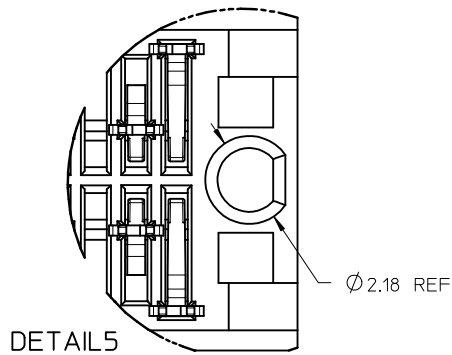

DETAIL1

REVISED EC NO: S2009-0427 DRWN: VINSOHNHUANG 2008/12/10 CHKD: JESSIECHUA 2008/12/10 APPR: NAGESHKN 2008/12/11	DESCRIPTION C2	QUALITY SYMBOLS	GENERAL TOLERANCES (UNLESS SPECIFIED)	DIMENSION STYLE MM ONLY	SCALE NTS	DESIGN UNITS METRIC	THIRD ANGLE PROJECTION																																							
		▼=0 □=0	<table border="1"> <thead> <tr> <th></th> <th>mm</th> <th>INCH</th> </tr> </thead> <tbody> <tr> <td>4 PLACES</td> <td>± ---</td> <td>± ---</td> </tr> <tr> <td>3 PLACES</td> <td>± ---</td> <td>± ---</td> </tr> <tr> <td>2 PLACES</td> <td>± 0.15</td> <td>± ---</td> </tr> <tr> <td>1 PLACE</td> <td>± ---</td> <td>± ---</td> </tr> </tbody> </table>		mm	INCH	4 PLACES	± ---	± ---	3 PLACES	± ---	± ---	2 PLACES	± 0.15	± ---	1 PLACE	± ---	± ---	<table border="1"> <thead> <tr> <th>DRAWN BY</th> <th>DATE</th> <th>TITLE</th> </tr> </thead> <tbody> <tr> <td>JTAN</td> <td>2005/07/01</td> <td rowspan="3">PCI EXPRESS EDGE CARD CONNECTOR, PRESS-FIT</td> </tr> <tr> <td>CHECKED BY</td> <td>DATE</td> </tr> <tr> <td>SRRAMESH</td> <td>2005/10/10</td> </tr> <tr> <td>APPROVED BY</td> <td>DATE</td> <td rowspan="2">MOLEX INCORPORATED</td> </tr> <tr> <td>GGLEE</td> <td>2005/10/10</td> </tr> <tr> <td>MATERIAL NO.</td> <td>SEE TABLE</td> <td>DOCUMENT NO.</td> <td>SD-78028-001</td> </tr> <tr> <td colspan="2">DRAFT WHERE APPLICABLE MUST REMAIN WITHIN DIMENSIONS</td> <td>SIZE A3</td> <td colspan="5">THIS DRAWING CONTAINS INFORMATION THAT IS PROPRIETARY TO MOLEX INCORPORATED AND SHOULD NOT BE USED WITHOUT WRITTEN PERMISSION</td> </tr> </tbody></table>	DRAWN BY	DATE	TITLE	JTAN	2005/07/01	PCI EXPRESS EDGE CARD CONNECTOR, PRESS-FIT	CHECKED BY	DATE	SRRAMESH	2005/10/10	APPROVED BY	DATE	MOLEX INCORPORATED	GGLEE	2005/10/10	MATERIAL NO.	SEE TABLE	DOCUMENT NO.	SD-78028-001	DRAFT WHERE APPLICABLE MUST REMAIN WITHIN DIMENSIONS		SIZE A3	THIS DRAWING CONTAINS INFORMATION THAT IS PROPRIETARY TO MOLEX INCORPORATED AND SHOULD NOT BE USED WITHOUT WRITTEN PERMISSION				
			mm	INCH																																										
		4 PLACES	± ---	± ---																																										
3 PLACES	± ---	± ---																																												
2 PLACES	± 0.15	± ---																																												
1 PLACE	± ---	± ---																																												
DRAWN BY	DATE	TITLE																																												
JTAN	2005/07/01	PCI EXPRESS EDGE CARD CONNECTOR, PRESS-FIT																																												
CHECKED BY	DATE																																													
SRRAMESH	2005/10/10																																													
APPROVED BY	DATE	MOLEX INCORPORATED																																												
GGLEE	2005/10/10																																													
MATERIAL NO.	SEE TABLE	DOCUMENT NO.	SD-78028-001																																											
DRAFT WHERE APPLICABLE MUST REMAIN WITHIN DIMENSIONS		SIZE A3	THIS DRAWING CONTAINS INFORMATION THAT IS PROPRIETARY TO MOLEX INCORPORATED AND SHOULD NOT BE USED WITHOUT WRITTEN PERMISSION																																											

9 8 7 6 5 4 3 2 1

MODULE CARD
(PER PCI EXPRESS CARD ELECTROMECHANICAL SPECIFICATION, REV. 1.1)

PORT SIZE	DIM 'X'	DIM 'Y'
X1	6.0	8.15
X4	20.0	22.15
X8	37.0	39.15
X16	70.0	72.15

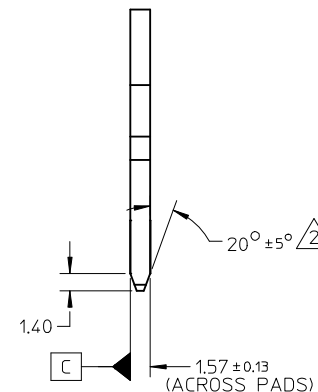
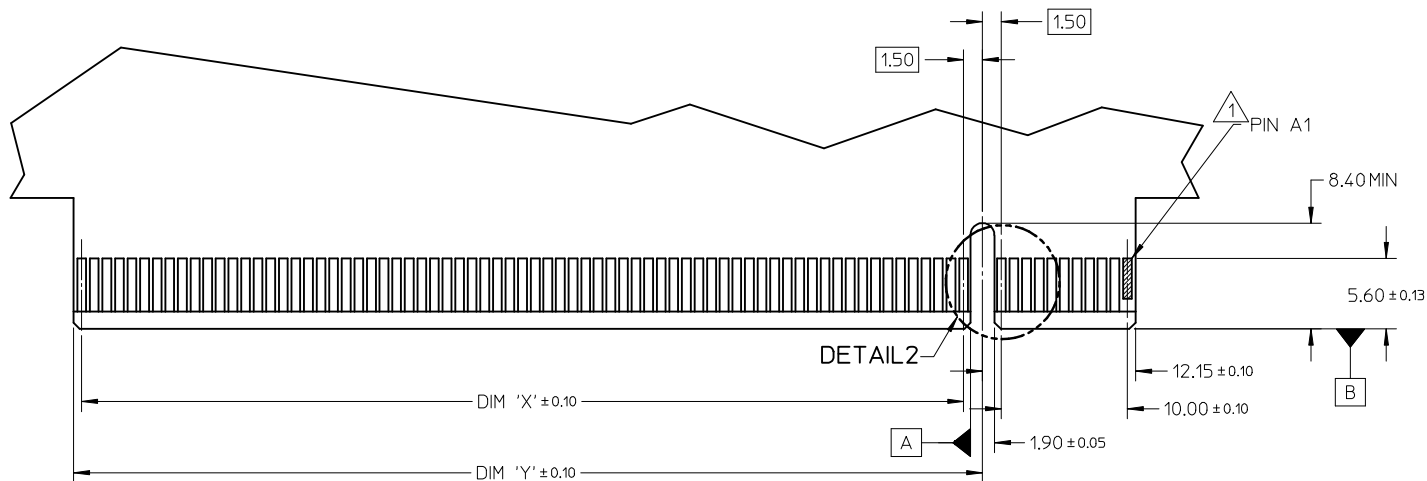

SECONDARY (SOLDER SIDE)

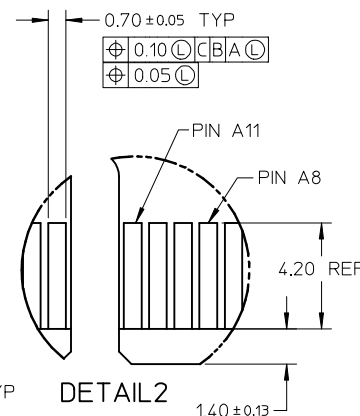
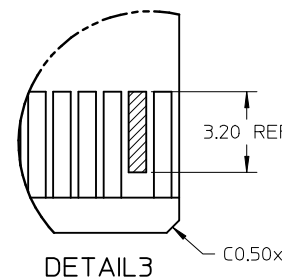
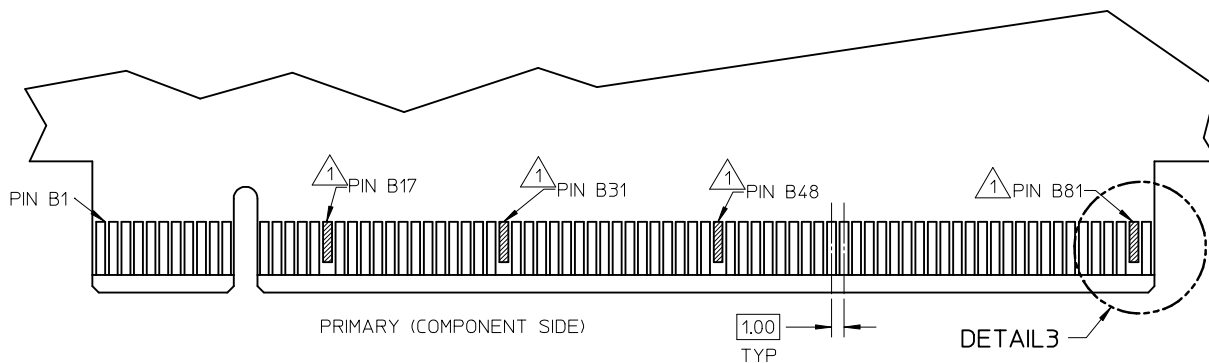

- NOTES :
- 1 NO TIE BAR PERMITTED FROM CARD EDGE TO LEADING EDGE OF PAD FOR PIN A1, B17, B31, B48 & B81 (X24 MODULE CARD PIN NO. NOT INCLUDED, TBD).
 - 2 CHAMFER EDGE MUST BE FREE FROM CUTTING BURRS.

REVISED EC NO: S2009-0427 DRWN:VINSUNHUANG 2008/12/10 CHKD:JESSIECHUA 2008/12/10 APPR:NAAGESHKN 2008/12/11	QUALITY SYMBOLS	GENERAL TOLERANCES (UNLESS SPECIFIED)	DIMENSION STYLE MM ONLY	SCALE NTS	DESIGN UNITS METRIC	THIRD ANGLE PROJECTION
	DESCRIPTION	mm INCH	DRAWN BY JTAN	DATE 2005/07/01	TITLE PCI EXPRESS EDGE CARD CONNECTOR, PRESS-FIT	
	REV	4 PLACES ± --- ± --- 3 PLACES ± --- ± --- 2 PLACES ± 0.15 ± --- 1 PLACE ± --- ± --- ANGULAR ± 1°	CHECKED BY SRRAMESH	DATE 2005/10/10	MOLEX INCORPORATED	
		DRAFT WHERE APPLICABLE MUST REMAIN WITHIN DIMENSIONS	APPROVED BY GGLEE	DATE 2005/10/10	MATERIAL NO. SEE TABLE	DOCUMENT NO. SD-78028-001

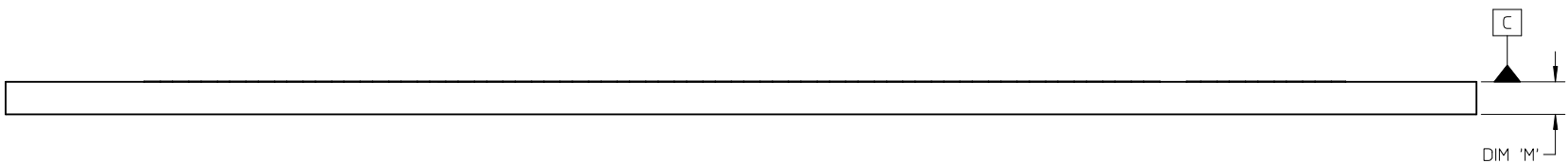
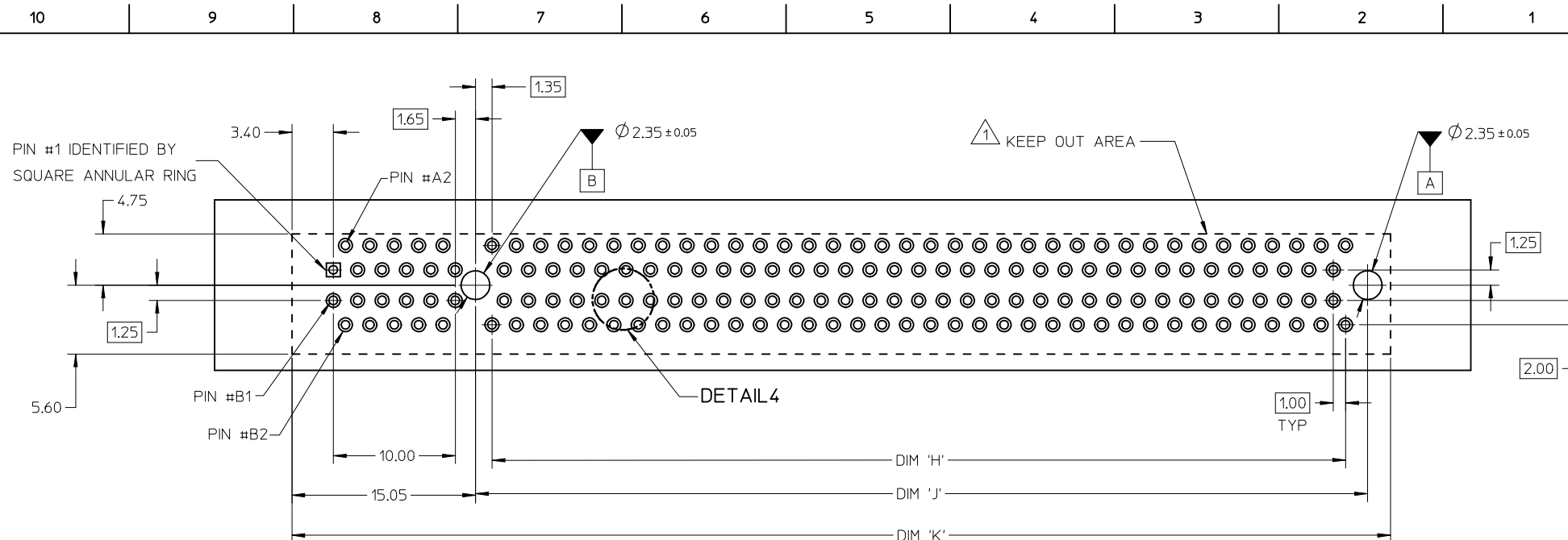

PORT SIZE	DIM 'H'	DIM 'J'	DIM 'K'
X1	6.0	9.15	26.00
X4	20.0	23.15	40.00
X8	37.0	40.15	57.00
X16	70.0	73.15	90.00

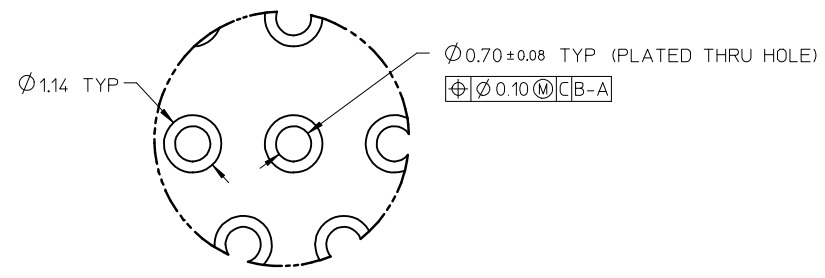

NOTES :
 1 THE KEEP OUT AREA IS THE AREA WHERE THE CONNECTOR IS MOUNTED ONTO THE PCB.

REVISED EC NO: S2009-0427 DRWN: WINSOONHUANG 2008/12/10 CHKD: JESSIECHUA 2008/12/10 APPR: NAGESHKN 2008/12/11	QUALITY SYMBOLS	GENERAL TOLERANCES (UNLESS SPECIFIED)	DIMENSION STYLE	SCALE	DESIGN UNITS	THIRD ANGLE PROJECTION															
	$\nabla=0$ $\nabla=0$	<table border="1"> <tr> <td></td> <td>mm</td> <td>INCH</td> </tr> <tr> <td>4 PLACES</td> <td>± ---</td> <td>± ---</td> </tr> <tr> <td>3 PLACES</td> <td>± ---</td> <td>± ---</td> </tr> <tr> <td>2 PLACES</td> <td>± 0.15</td> <td>± ---</td> </tr> <tr> <td>1 PLACE</td> <td>± ---</td> <td>± ---</td> </tr> </table>		mm	INCH	4 PLACES	± ---	± ---	3 PLACES	± ---	± ---	2 PLACES	± 0.15	± ---	1 PLACE	± ---	± ---	MM ONLY	NTS	METRIC	
		mm	INCH																		
	4 PLACES	± ---	± ---																		
3 PLACES	± ---	± ---																			
2 PLACES	± 0.15	± ---																			
1 PLACE	± ---	± ---																			
DESCRIPTION	ANGULAR ± 1 °	DRAWN BY	DATE	TITLE																	
REV		DRAFT WHERE APPLICABLE MUST REMAIN WITHIN DIMENSIONS	JTAN	2005/07/01	PCI EXPRESS EDGE CARD CONNECTOR, PRESS-FIT																
			SRRAMESH	2005/10/10	MOLEX INCORPORATED																
			GGLEE	2005/10/10				DOCUMENT NO.	SHEET NO.												
C2			SEE TABLE		SD-78028-001	4 OF 8															
			SIZE A3	THIS DRAWING CONTAINS INFORMATION THAT IS PROPRIETARY TO MOLEX INCORPORATED AND SHOULD NOT BE USED WITHOUT WRITTEN PERMISSION																	

TIN OPTION

PART NO.	PORT SIZE	CKTS SIZE	DIM 'A'	DIM 'B'	DIM 'C'	DIM 'D'	DIM 'E'	DIM 'F'	DIM 'G'	DIM 'P'	DIM 'M'	DIM 'N'	CONTACT AREA PLATING OPTION	SOLDERTAIL PLATING OPTION
78028-0001	X1	36	25.0	6.0	8.5	9.15	4.04	2.04	1.20	2.54	2.29	0.25	0.76uM/30uIN MIN GOLD OVER 1.27uM/50uIN MIN NICKEL UNDERPLATE	0.38-1.52uM/15-60uIN TIN (MATTE) OVER 1.27uM/50uIN MIN NICKEL UNDERPLATE
78028-0101										2.79	2.54			
78028-1101										3.43	3.18			
78028-0011										2.54	2.29			
78028-0111										2.79	2.54			
78028-1111										3.43	3.18			
78028-0004	X4	64	39.0	20.0	22.50	23.15	3.00	1.00	1.00	2.54	2.29	0.25	0.76uM/30uIN MIN GOLD OVER 1.27uM/50uIN MIN NICKEL UNDERPLATE	0.38-1.52uM/15-60uIN TIN (MATTE) OVER 1.27uM/50uIN MIN NICKEL UNDERPLATE
78028-0104										2.79	2.54			
78028-1104										3.43	3.18			
78028-0014										2.54	2.29			
78028-0114										2.79	2.54			
78028-1114										3.43	3.18			

REVISED EC NO: S2009-0427 DRW: WYINSONHUANG 2008/12/10 CH: KD: JESSIE CHUA 2008/12/10 APPR: NAGESHKN 2008/12/11	QUALITY SYMBOLS	GENERAL TOLERANCES (UNLESS SPECIFIED)	DIMENSION STYLE	SCALE	DESIGN UNITS	THIRD ANGLE PROJECTION
	▼=0 ▽=0	mm INCH 4 PLACES ± --- ± --- 3 PLACES ± --- ± --- 2 PLACES ± 0.15 ± --- 1 PLACE ± --- ± --- ANGULAR ± 1 °	MM ONLY	NTS	METRIC	
	DESCRIPTION	DRAFT WHERE APPLICABLE MUST REMAIN WITHIN DIMENSIONS	DRAWN BY JTAN	DATE 2005/07/01	TITLE PCI EXPRESS EDGE CARD CONNECTOR, PRESS-FIT	
	REV		CHECKED BY SRRAMESH	DATE 2005/10/10	MOLEX INCORPORATED	
			APPROVED BY GGLLEE	DATE 2005/10/10	DOCUMENT NO. SD-78028-001	
			MATERIAL NO. SEE TABLE		SHEET NO. 6 OF 8	
			SIZE A3	THIS DRAWING CONTAINS INFORMATION THAT IS PROPRIETARY TO MOLEX INCORPORATED AND SHOULD NOT BE USED WITHOUT WRITTEN PERMISSION		

TIN OPTION

PART NO.	PORT SIZE	CKTS SIZE	DIM 'A'	DIM 'B'	DIM 'C'	DIM 'D'	DIM 'E'	DIM 'F'	DIM 'G'	DIM 'P'	DIM 'M'	DIM 'N'	CONTACT AREA PLATING OPTION	SOLDERTAIL PLATING OPTION
78028-0008	X8	98	56.0	37.0	39.50	40.15	4.00	2.00	1.20	2.54	2.29	0.25	0.76μM/30uIN MIN GOLD OVER 1.27μM/50uIN MIN NICKEL UNDERPLATE	0.38-1.52μM/15-60uIN TIN (MATTE) OVER 1.27μM/50uIN MIN NICKEL UNDERPLATE
78028-0108										2.79	2.54			
78028-1108										3.43	3.18			
78028-0018										2.54	2.29			
78028-0118										2.79	2.54			
78028-1118										3.43	3.18			
78028-0016	X16	164	89.0	70.0	72.50	73.15	5.00	2.50	1.00	2.54	2.29	0.25	0.76μM/30uIN MIN GOLD OVER 1.27μM/50uIN MIN NICKEL UNDERPLATE	
78028-0116										2.79	2.54			
78028-1116										3.43	3.18			
78028-0026										2.54	2.29			
78028-0126										2.79	2.54			
78028-1126										3.43	3.18			

REVISED EC NO: S2009-0427 DRW:WJ INSONHUANG 2008/12/10 CHKD: JESS IECHUA 2008/12/10 APPR: NAGESHKN 2008/12/11	QUALITY SYMBOLS ▽=0 ◻=0	GENERAL TOLERANCES (UNLESS SPECIFIED) mm INCH 4 PLACES ± --- ± --- 3 PLACES ± --- ± --- 2 PLACES ± 0.15 ± --- 1 PLACE ± --- ± --- ANGULAR ± 1 °	DIMENSION STYLE MM ONLY	SCALE NTS	DESIGN UNITS METRIC	THIRD ANGLE PROJECTION	
	DRAWN BY JTAN	DATE 2005/07/01	TITLE PCI EXPRESS EDGE CARD CONNECTOR, PRESS-FIT				
	CHECKED BY SRRAMESH	DATE 2005/10/10	APPROVED BY GGLEE				
	MATERIAL NO. SEE TABLE	DATE 2005/10/10	MOLEX INCORPORATED			DOCUMENT NO. SD-78028-001	SHEET NO. 7 OF 8

DRAFT WHERE APPLICABLE MUST REMAIN WITHIN DIMENSIONS

SIZE A3 THIS DRAWING CONTAINS INFORMATION THAT IS PROPRIETARY TO MOLEX INCORPORATED AND SHOULD NOT BE USED WITHOUT WRITTEN PERMISSION

TIN / LEAD OPTION

PART NO.	PORT SIZE	CKTS SIZE	DIM 'A'	DIM 'B'	DIM 'C'	DIM 'D'	DIM 'E'	DIM 'F'	DIM 'G'	DIM 'P'	DIM 'M'	DIM 'N'	CONTACT AREA PLATING OPTION	SOLDERTAIL PLATING OPTION
78028-0071	X1	36	25.0	6.0	8.5	9.15	4.04	2.04	1.20	2.54	2.29	0.25	0.76uM/30uIN MIN GOLD OVER 1.27uM/50uIN MIN NICKEL UNDERPLATE	0.38-1.52uM/15-60uIN TIN / LEAD OVER 1.27uM/50uIN MIN NICKEL UNDERPLATE
78028-0171										2.79	2.54			
78028-1171										3.43	3.18			
78028-0081										2.54	2.29		0.38uM/15uIN MIN GOLD OVER 1.27uM/50uIN MIN NICKEL UNDERPLATE	
78028-0181										2.79	2.54			
78028-1181										3.43	3.18			
78028-0074	X4	64	39.0	20.0	22.50	23.15	3.00	1.00	1.00	2.54	2.29	0.25	0.76uM/30uIN MIN GOLD OVER 1.27uM/50uIN MIN NICKEL UNDERPLATE	
78028-0174										2.79	2.54			
78028-1174										3.43	3.18			
78028-0084										2.54	2.29		0.38uM/15uIN MIN GOLD OVER 1.27uM/50uIN MIN NICKEL UNDERPLATE	
78028-0184										2.79	2.54			
78028-1184										3.43	3.18			

REVISED IEC NO: S2009-0427 DRWN: WINSUNHUANG 2008/12/10 CHKD: JESSIE CHUA 2008/12/10 APPR: NAGESHKN 2008/12/11	QUALITY SYMBOLS	GENERAL TOLERANCES (UNLESS SPECIFIED)	DIMENSION STYLE	SCALE	DESIGN UNITS	THIRD ANGLE PROJECTION
	▽=0 ▽=0	mm INCH 4 PLACES ± --- ± --- 3 PLACES ± --- ± --- 2 PLACES ± 0.15 ± --- 1 PLACE ± --- ± --- ANGULAR ± 1 °	MM ONLY	NTS	METRIC	
	DESCRIPTION	DRAFT WHERE APPLICABLE MUST REMAIN WITHIN DIMENSIONS	DRAWN BY	DATE	TITLE	
	REV		JTAN	2005/07/01	PCI EXPRESS EDGE CARD CONNECTOR, PRESS-FIT	
	C2		CHECKED BY	DATE	MOLEX INCORPORATED	
		SRRAMESH	2005/10/10	MOLEX INCORPORATED		
		APPROVED BY	DATE	DOCUMENT NO.		
		GGLEE	2005/10/10	SD-78028-001		
		MATERIAL NO.		SHEET NO.		
		SEE TABLE		8 OF 8		
		SIZE A3	THIS DRAWING CONTAINS INFORMATION THAT IS PROPRIETARY TO MOLEX INCORPORATED AND SHOULD NOT BE USED WITHOUT WRITTEN PERMISSION			

10 9 8 7 6 5 4 3 2 1

TIN / LEAD OPTION

PART NO.	PORT SIZE	CKTS SIZE	DIM 'A'	DIM 'B'	DIM 'C'	DIM 'D'	DIM 'E'	DIM 'F'	DIM 'G'	DIM 'P'	DIM 'M'	DIM 'N'	CONTACT AREA PLATING OPTION	SOLDERTAIL PLATING OPTION
78028-0078	X8	98	56.0	37.0	39.50	40.15	4.00	2.00	1.20	2.54	2.29	0.25	0.76uM/30uIN MIN GOLD OVER 1.27uM/50uIN MIN NICKEL UNDERPLATE	0.38-1.52uM/15-60uIN TIN / LEAD OVER 1.27uM/50uIN MIN NICKEL UNDERPLATE
78028-0178										2.79	2.54			
78028-1178										3.43	3.18			
78028-0088										2.54	2.29			
78028-0188										2.79	2.54			
78028-1188										3.43	3.18			
78028-0076	X16	164	89.0	70.0	72.50	73.15	5.00	2.50	1.00	2.54	2.29	0.25	0.76uM/30uIN MIN GOLD OVER 1.27uM/50uIN MIN NICKEL UNDERPLATE	
78028-0176										2.79	2.54			
78028-1176										3.43	3.18			
78028-0086										2.54	2.29			
78028-0186										2.79	2.54			
78028-1186										3.43	3.18			

REVISED EC NO: S2009-0427 DRWN: VVINSONHUANG 2008/12/10 CHKD: JESSIECHUA 2008/12/10 APPR: NAGESHKN 2008/12/11	QUALITY SYMBOLS ▽=0 ◻=0	GENERAL TOLERANCES (UNLESS SPECIFIED) mm INCH 4 PLACES ± --- ± --- 3 PLACES ± --- ± --- 2 PLACES ± 0.15 ± --- 1 PLACE ± --- ± --- ANGULAR ± 1 °	DIMENSION STYLE MM ONLY	SCALE NTS	DESIGN UNITS METRIC	THIRD ANGLE PROJECTION
	DRAWN BY JTAN	DATE 2005/07/01	TITLE PCI EXPRESS EDGE CARD CONNECTOR, PRESS-FIT			
	CHECKED BY SRRAMESH	DATE 2005/10/10	MOLEX INCORPORATED			
	APPROVED BY GGLEE	DATE 2005/10/10	MATERIAL NO. SEE TABLE	DOCUMENT NO. SD-78028-001	SHEET NO. 8 OF 8	

9 8 7 6 5 4 3 2 1