

AFE5818 16-Channel Analog Front End Evaluation Module (EVM Rev. C)

This user's guide gives a general overview of the AFE5818 evaluation module (EVM) and provides a general description of the features and functions to be considered while using this module. This manual is applicable to the AFE5818 analog front-end, and to the Rev. C version of the EVM hardware. The AFE5818 EVM provides a platform for evaluating the AFE under various signal, clock, reference, and ADC output formats. In addition, the EVM supports the testing of the LVDS interface. Note that if using the LVDS interface, the TSW1400EVM capture card is required.

This user's guide refers to software HMC-DAQ GUI v.2.8 or higher, and HSDCPro Software v.4.1 or higher and requires Microsoft® Windows® 7 to function.

For any further questions regarding the EVM, GUI or device, please contact: AFE5818-support@list.ti.com

Contents

1	EVM Hardware Overview	4
2	GUI Software Installation	5
3	Quick Views of Evaluation Setups for LVDS Interface.....	6
3.1	Equipment Setup Overview	6
4	Testing the EVM Data Capture With LVDS	8
4.1	EVM Hardware Setup	8
4.2	Capturing an Analog Input Signal With the LVDS Interface.....	9
5	Testing the EVM in CW Mode	16
Appendix A	Software Installation	18
Appendix B	Hardware Configuration	31
Appendix C	Triggering Options.....	35
Appendix D	Common Hardware Modifications	37
Appendix E	Hardware Reference	38
Appendix F	FAQ and Troubleshooting	57

List of Figures

1	AFE5818 EVM Hardware Overview	4
2	Provided Power Cable for J1 Connector	5
3	LVDS Evaluation Setup Overview	6
4	TSW1400EVM and AFE5818 EVM Hardware Setup for LVDS Capture	8
5	Connect to TSW EVM (TSW1400 Shown)	9
6	Connect to TSW EVM.....	9
7	Choose Firmware (AFE5818 Shown).....	10
8	Update Firmware?.....	10
9	Firmware Download Progress Bar	10
10	TSW LEDs Turn On After FW Download	11
11	Launching Device GUI EXE	11
12	HMC-DAQ GUI Launches.....	12
13	Clock Configuration on AFE EVM for LVDS	12
14	AFE_RST Hardware Reset Button.....	13
15	Software Reset Button.....	13

16	Initialize Device	13
17	GUI Quick Start Setup: Output Data Configuration	13
18	LED D5 Turns On When ADC is Ready	14
19	Choose VCA Gain.....	14
20	Capture Button.....	14
21	Analog Input Capture	15
22	Initialize Device	16
23	CW Mode Preset	16
24	CW Output	17
25	HSDCPro Install (Begin).....	18
26	HSDCPro Install (TI License Agreement)	19
27	HSDCPro Install (TI License Agreement)	19
28	HSDCPro Install (Install Directory)	20
29	HSDCPro Install (Installation Ready)	20
30	HSDCPro Install (Cypress Driver Install).....	21
31	HSDCPro Install (Continue Cypress Driver Installation)	21
32	HSDCPro Install (Continue Driver Installation)	22
33	HSDCPro Install (Finish Installation).....	22
34	HMC-DAQ GUI Install (Begin Installation)	23
35	HMC-DAQ GUI Install (TI License Agreement)	23
36	HMC-DAQ GUI Install(NI License Agreement)	24
37	HMC-DAQ GUI Install (Install Directory)	24
38	HMC-DAQ GUI Install (Installation Ready)	25
39	HMC-DAQ GUI Install (Installation Progress)	25
40	HMC-DAQ GUI Install (LabView Run-time Engine Installation)	26
41	HMC-DAQ GUI Install (LabView Run-time Engine Installation)	26
42	HMC-DAQ GUI Install (LabView Run-time Engine Installation)	27
43	HMC-DAQ GUI Install (LabView Run-time Engine Installation)	27
44	HMC-DAQ GUI Install (LabView Run-time Engine Installation)	28
45	HMC-DAQ GUI Install (LabView Run-time Engine Installation)	29
46	HMC-DAQ GUI Install: (LabView RTE Cancel, if Installed Already).....	29
47	HMC-DAQ GUI Install (Finished)	30
48	Default Jumper Positions	31
49	EVM ADC Clock Source Configuration.....	33
50	EVM ADC Clock Source Configuration Examples	34
51	HSDCPro Trigger Configuration for SW.....	35
52	HSDCPro Trigger Configuration for SW trigger	35
53	HSDCPro Trigger Configuration for HW	36
54	HSDCPro Trigger Configuration for HW External Trigger	36
55	AFE5818 EVM Circuits Map	38
56	AFE5818 EVM Block Diagram	39
57	AFE5816 Rev C EVM Schematic 1 of 11	40
58	AFE5818 Rev C EVM Schematic 2 of 11	41
59	AFE5818 Rev C EVM Schematic 3 of 11	42
60	AFE5818 Rev C EVM Schematic 4 of 11	43
61	AFE5818 Rev C EVM Schematic 5 of 11	44
62	AFE5818 Rev C EVM Schematic 6 of 11	45
63	AFE5818 Rev C EVM Schematic 7 of 11	46
64	AFE5818 Rev C EVM Schematic 8 of 11	47

65	AFE5818 Rev C EVM Schematic 9 of 11	48
66	AFE5818 Rev C EVM Schematic 10 of 11	49
67	AFE5818 Rev C EVM Schematic 11 of 11	50
68	Enable .NET Framework	57
69	Read DDR Error for No Capture	58

List of Tables

1	Default Header Configuration Table Rev.C	32
2	EVM Rev.C Testpoints	32
3	AFE5818 EVM Bill of Materials	51

1 EVM Hardware Overview

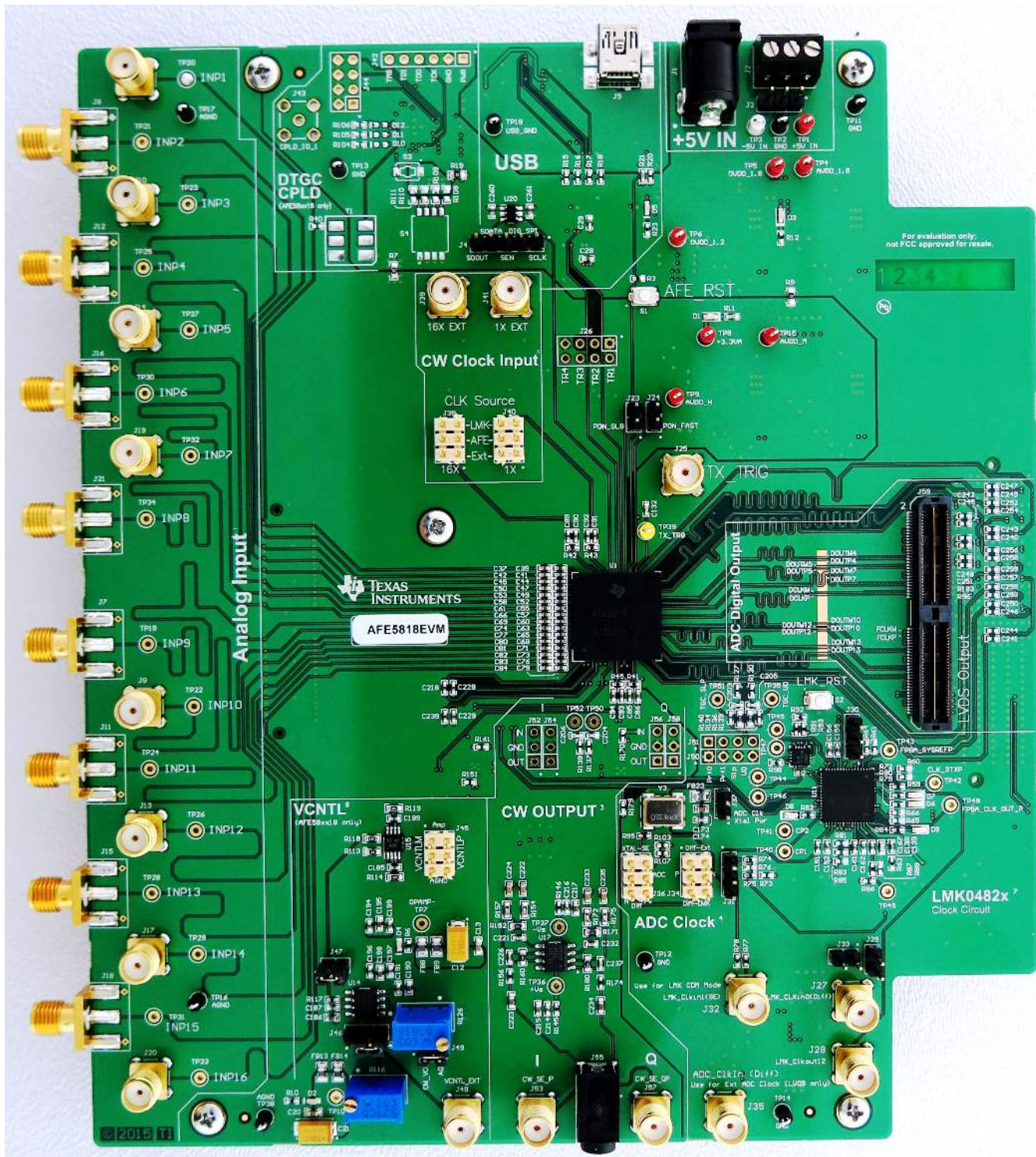

Figure 1. AFE5818 EVM Hardware Overview

The EVM received should resemble [Figure 1](#). For more hardware details and the default jumper map, see [Appendix B](#).

The AFE5818 EVM kit contains the following items:

1. AFE5818 EVM
2. 1 mini-USB cable
3. Power cable with barrel connector



Figure 2. Provided Power Cable for J1 Connector

2 GUI Software Installation

The AFE5818 EVM and the TSW capture card EVM have individual software and both require software installations. Ensure that no USB connections are made to the EVMs until after the installations are complete. This user's guide refers to software HMC-DAQ GUI v.2.8 or higher, and HSDCPro Software v.4.1 or higher.

See the [HSDCPro Installation](#) section for information on the installation of the TSW EVM Software GUI (HSDCPro). For information on the installation of the AFE5818 EVM Software GUI (HMC-DAQ GUI), see the [HMC-DAQ GUI Installation](#) section.

3 Quick Views of Evaluation Setups for LVDS Interface

The AFE5818 EVM is tested using the TSW1400EVM for LVDS data interface.

3.1 Equipment Setup Overview

As shown in [Figure 3](#), mating the AFE5818 EVM with a TSW EVM allows for testing using the data interface.

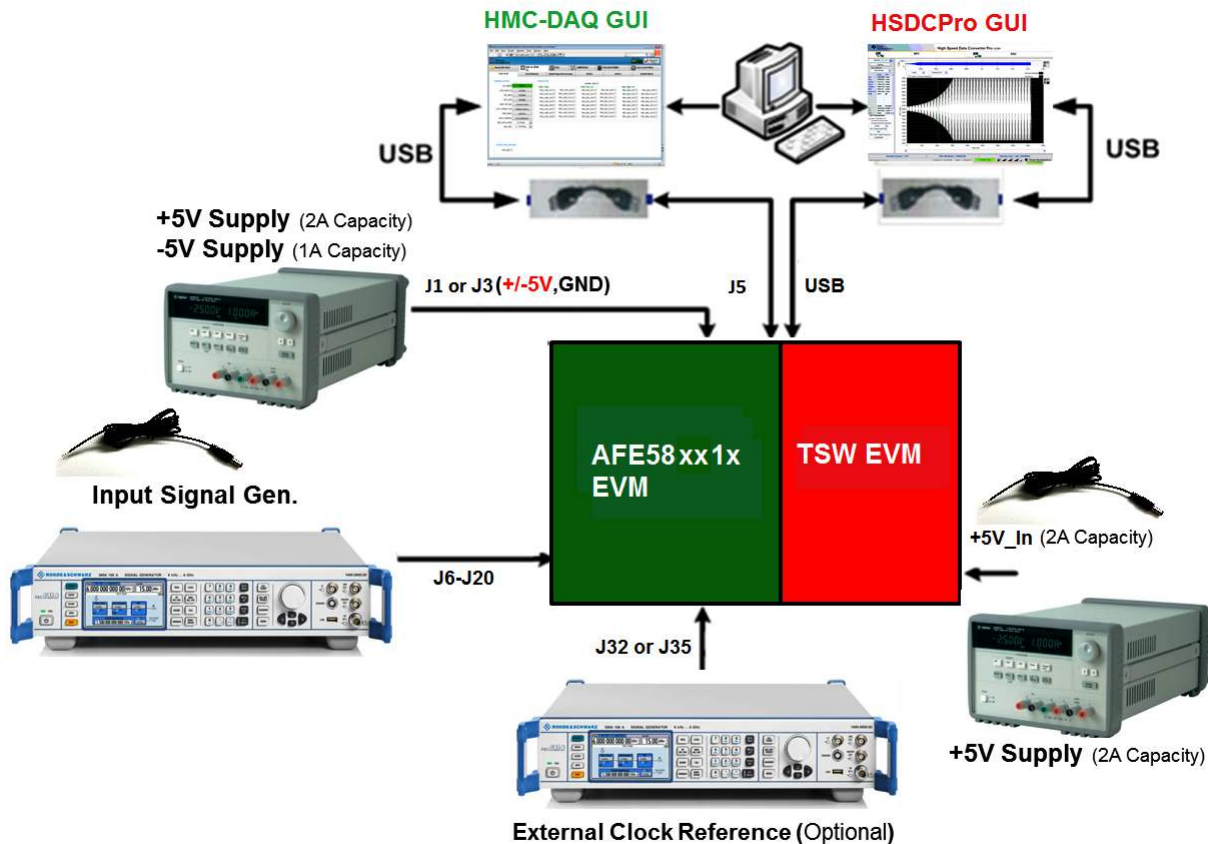

Figure 3. LVDS Evaluation Setup Overview

TSW Capture Card EVM: The TSW1400 EVM is required for capturing data from the AFE5818 EVM and its analysis using the graphical user interface (GUI), called High Speed Data Converter Pro (HSDCPro).

For more information on the TSW1400EVM, see: [TSW1400EVM](#).

Power Supply: A barrel connector power cable is provided with the EVM and is connected at J1, but does not support the -5 V needed for the CW mode or V_{ctrl} circuit. This requires an additional cable, not provided.

This 5-V power supply must be able to source up to 2 A , and -5-V supply must provide up to 1 A . The -5-V supply is used for the negative supply of amplifiers in the CW output external circuitry and V_{ctrl} circuit. The TSW1400 EVM is powered through a power cable similar to [Figure 2](#) that is provided with its own EVM kit.

USB Interface to PC: The USB connections from the AFE5818 EVM and TSW EVM to the PC are used for communication from the GUIs to the boards. USB 2.0 or 3.0 ports are both acceptable.

Equipment: Signal generators (with low-phase noise) must be used as source of the input signal (0.01 MHz to 40 MHz) for optimal performance. An on-board crystal oscillator option is provided so that an external clock source is not needed for basic capture. Additionally, for best performance a band-pass filter (BPF) is recommended on the analog input signal to attenuate the harmonics and noise from the signal. For coherent sampling or custom sample rate, an external clock is provided to J35 (GUI configuration is required for the external clock configuration). For more information on clock configuration, see [Section B.1.3](#).

4 Testing the EVM Data Capture With LVDS

This section outlines (1) the external connections required to test the AFE5818 EVM using the LVDS interface, (2) how to setup the GUIs for testing, and (3) how to capture an analog input signal.

4.1 EVM Hardware Setup

Make the connections shown in [Figure 4](#) or for proper hardware setup.

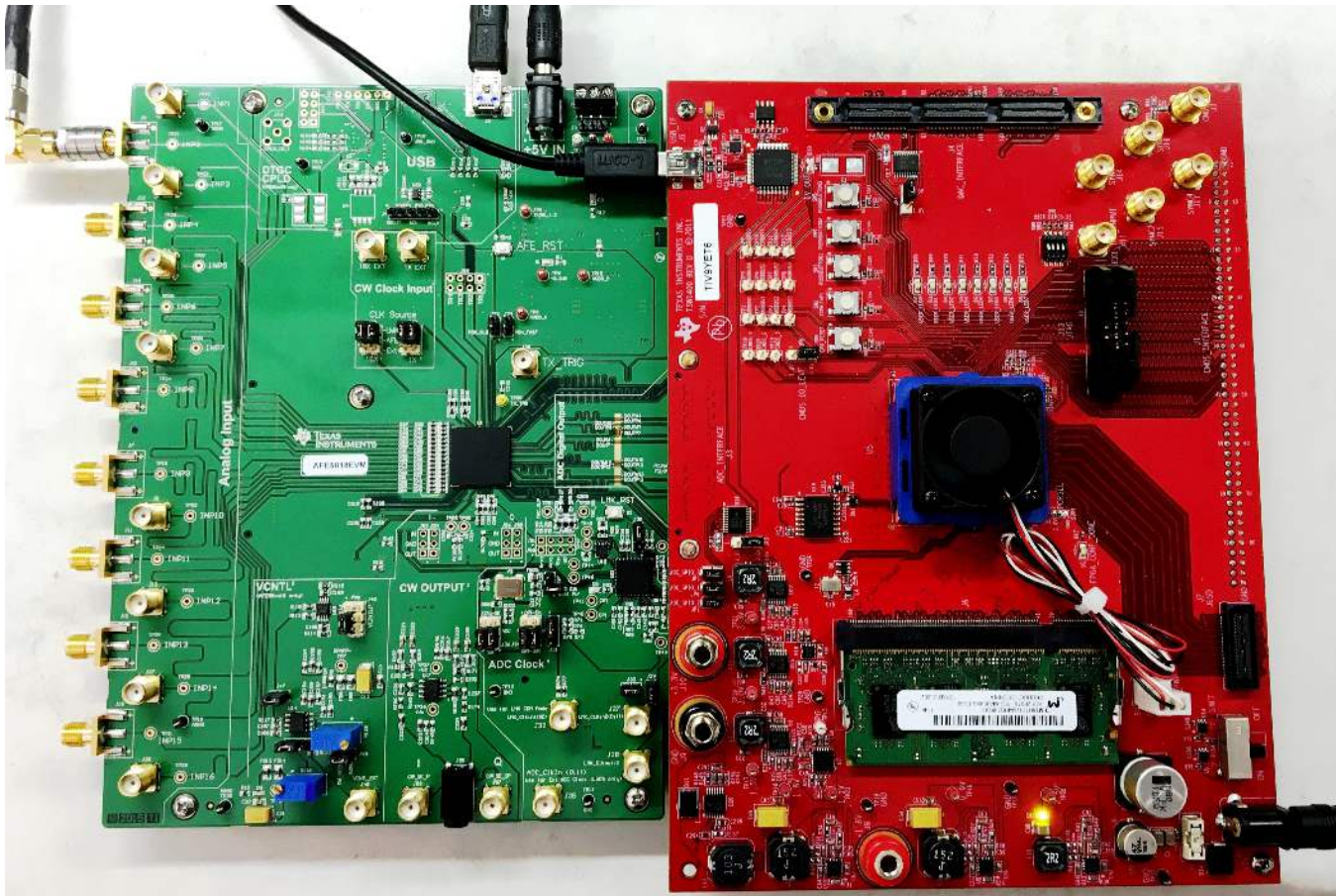

Figure 4. TSW1400EVM and AFE5818 EVM Hardware Setup for LVDS Capture

- Board Mating:** For LVDS data, mate the TSW1400 EVM at connector **J3** to the AFE5818 EVM at connector **J59** through the high-speed ADC interface connector.
- Power Supply:** Connect a 5-V (2-A) power supply using the provided power cable to **J12 (+5V_IN)** of the TSW1400 EVM. See the TSW manual for more information, if needed.
Next, connect a 5-V (2-A) power supply using the provided power cable to **J1** of the AFE5818 EVM. **Connect the white-striped side of this cable to the 5-V power supply.** Optionally, connect a -5-V (1-A) supply at J3 or TP3 if using the CW or Vcntl circuit. No cable is provided for this.
Turn on the TSW1400 at the SW7 switch.
- USB:** After installing the GUIs as shown in [Appendix A](#), connect the USB cable from PC to **J5 (USB)** located on the top side of the AFE5818 EVM. Connect the USB cable from PC to **J5 (USB_IF)** of the TSW1400 EVM. USB 2.0 or 3.0 ports are both acceptable for both EVMs. *Note: TI recommends that the PC USB port be able to support USB2.0. If unsure, always choose the USB ports at the back of the PC chassis over ones located on the front or sides.*
- Equipment:** Connect a sine wave generator to SMA **J6**, **INP1**. Set the frequency to 5 MHz and the amplitude to -30 dBm. For best performance, a 5-MHz band-pass filter (BPF) is recommended on the analog input signal to attenuate the harmonics and noise from the signal.

4.2 Capturing an Analog Input Signal With the LVDS Interface

This section describes the software setup for capturing an analog input using the AFE5818 EVM. If there is any issue with a data capture, refer to the troubleshooting section.

Data capture is confirmed by using only the Quick Setup page of the HMC-DAQ GUI. Assuming the hardware is connected correctly as in [Section 4.1](#), follow these steps to acquire data:

HSDCPro Actions:

1. Connect both EVMs to the PC using two USB cables as instructed in [Section 4.1](#).
2. Open HSDCPro GUI using *Run as Administrator*. **Do not open the HMC-DAQ GUI before this step because it opens automatically. If it is already open, close it.**
3. If the TSW Hardware is already connected to the USB, then a pop-up window should appear to connect the HSDCPro GUI to the EVM Hardware.

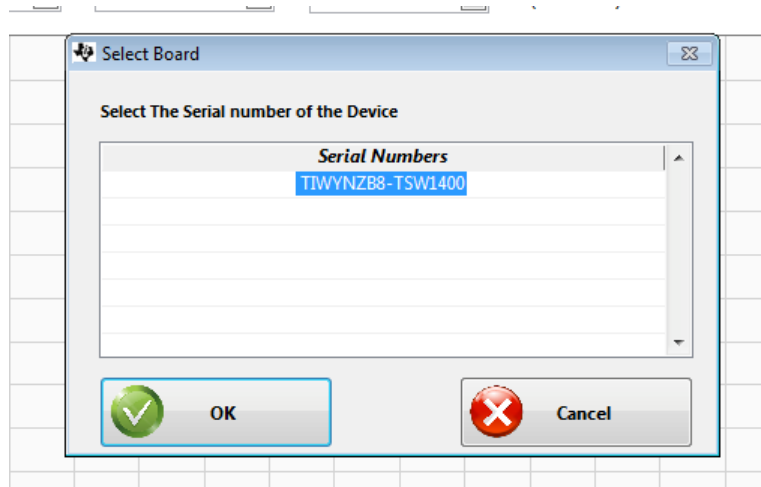

Figure 5. Connect to TSW EVM (TSW1400 Shown)

4. A pop-up window prompts the user to choose a firmware to download to the TSW EVM FPGA.

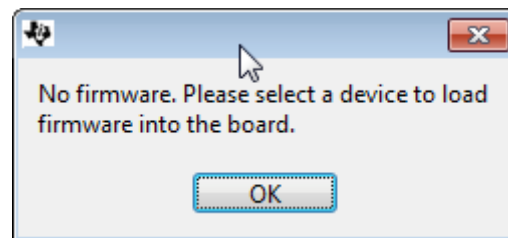

Figure 6. Connect to TSW EVM

5. Select firmware as 'AFE5818'. **Be sure to choose the correct device to match the hardware or the HMC-DAQ GUI shows an error when launching.**

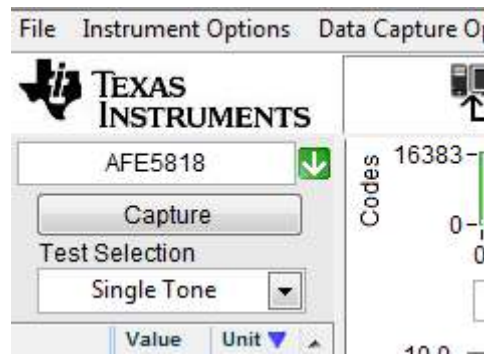

Figure 7. Choose Firmware (AFE5818 Shown)

- When prompted to update firmware, click the Yes button.

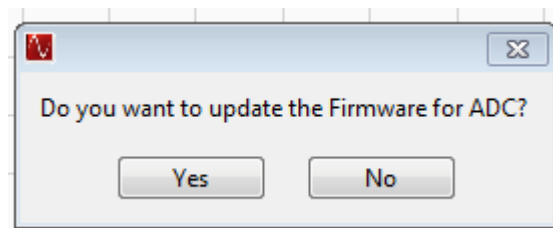

Figure 8. Update Firmware?

- The firmware begins downloading to the FPGA on the TSW EVM.

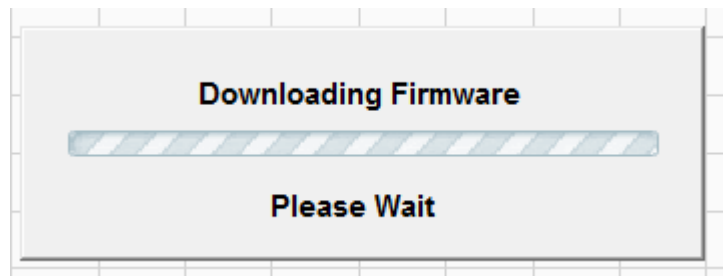

Figure 9. Firmware Download Progress Bar

- When the firmware has finished downloading, several Green LEDs are lit on the TSW EVM. For the TSW1400, D5 (USER_LED3) may be on, and D6 is off.

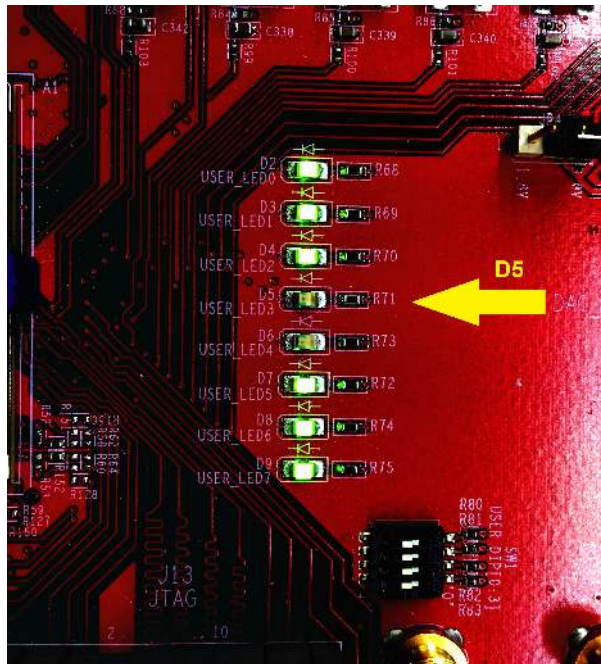

Figure 10. TSW LEDs Turn On After FW Download

9. The AFE5818 EVM GUI (HMC-DAQ) opens automatically at this time. Wait until this is finished to continue. If any errors arise at this time, consult a TI engineer.

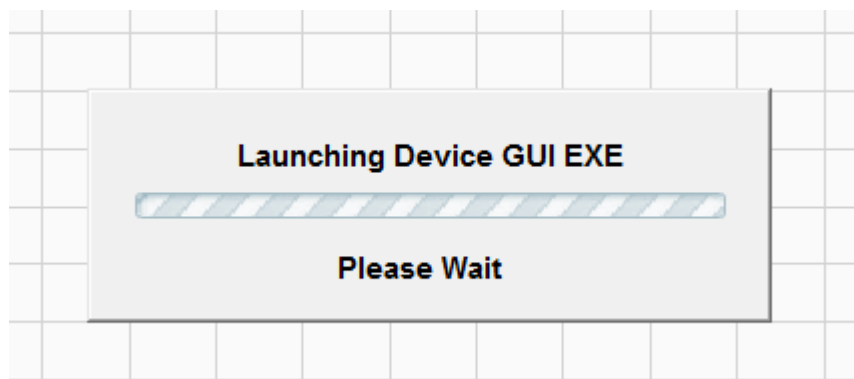

Figure 11. Launching Device GUI EXE

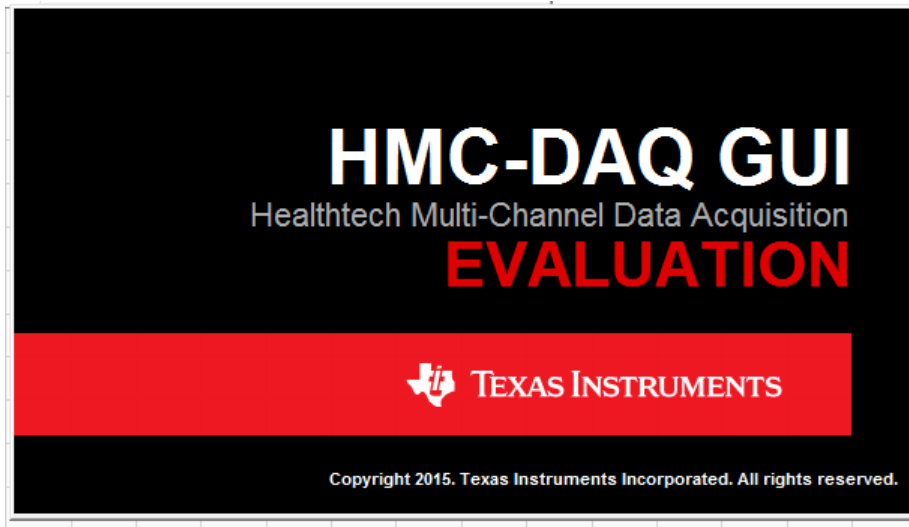

Figure 12. HMC-DAQ GUI Launches

10. In HSDCPro, change the Test Selection to *Single Tone*
11. In HSDCPro, change the window type to *Blackman*

HMC-DAQ GUI Actions:

1. Verify the clock configuration by matching J36, J34, J31, and J37 to [Figure 13](#).

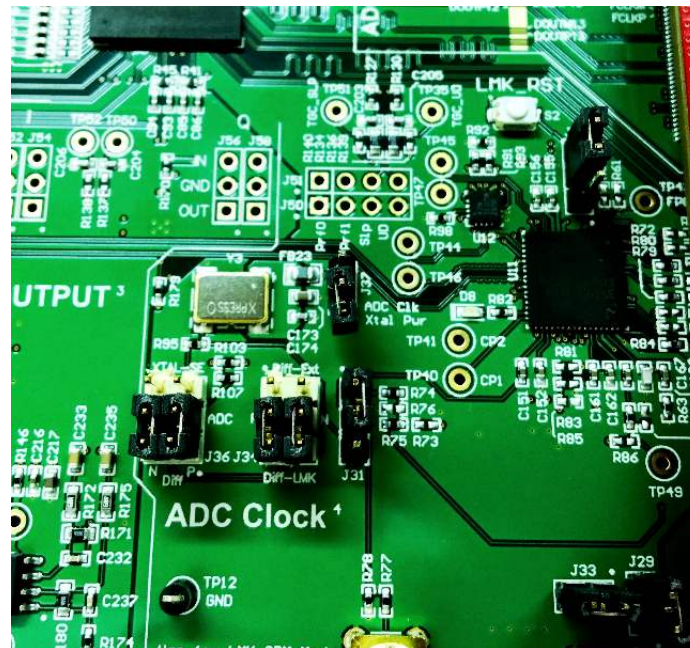

Figure 13. Clock Configuration on AFE EVM for LVDS

2. Press the AFE_RST button on the AFE EVM, located above the AFE device (SW1). Hold for 1 second. Alternatively, press the *DUT RESET* button on the HMC-DAQ GUI.

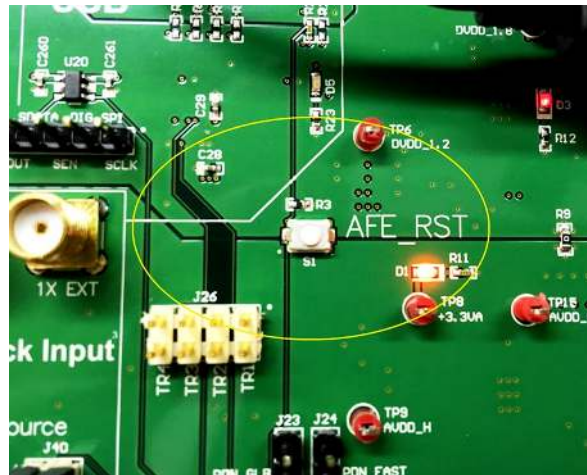

Figure 14. AFE_RST Hardware Reset Button

1. Verify clock jumper configuration and reset the device

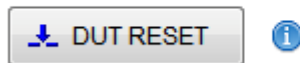
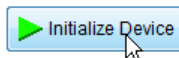

Figure 15. Software Reset Button

3. Press the *Initialize Device* button on the HMC-DAQ GUI. The progress bar indicates the device is configured over SPI.

2. Initialize Device for Data Capture



3. Choose Data Format

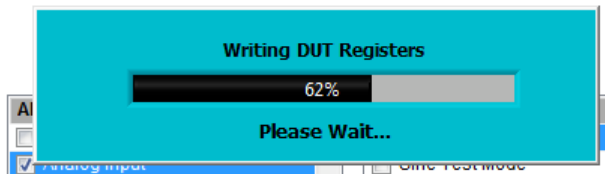
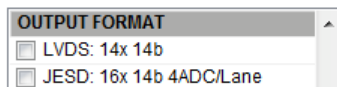

Figure 16. Initialize Device

4. Choose the desired serialized data format in the *Output Format* control.
5. The default ADC Format is *Analog Input*. This requires no action.

3. Choose Data Format

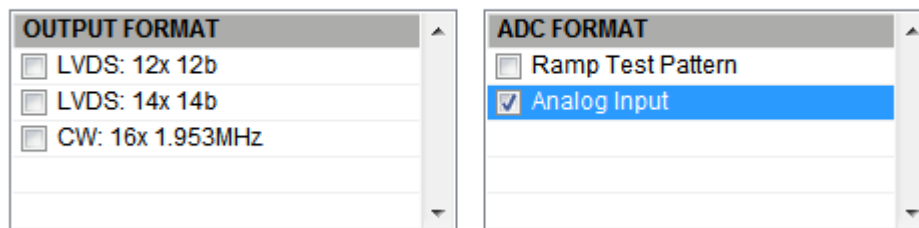

Figure 17. GUI Quick Start Setup: Output Data Configuration

6. At this point, D5 on the TSW1400 EVM should turn on. For the TSW14J56D, D3 turns off, and D4 should start blinking. If this is not the case, please consult the [Appendix F](#) section. There is most likely

an ADC clock issue.

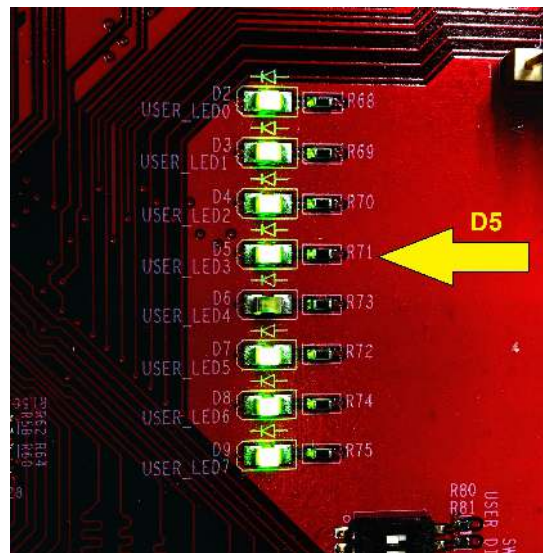

Figure 18. LED D5 Turns On When ADC is Ready

1. Choose VCA GAIN as *Mid Gain*.

4. Choose Analog Configuration

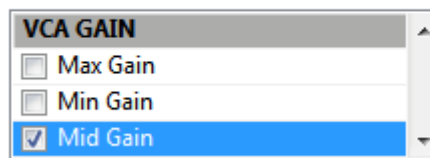

Figure 19. Choose VCA Gain

2. Return to HSDCPro, and press the *Capture* button. A capture similar to that shown in [Figure 21](#) appears. The quality of the output spectrum depends heavily on the coherency and the purity of the input signal and clock. Since it is not possible to sync the input signal with the on-board clock, TI recommends using a window in HSDCPro (found at the top of the spectrum graph). *Blackman* or *Hanning* works, do not use *Rectangular*.

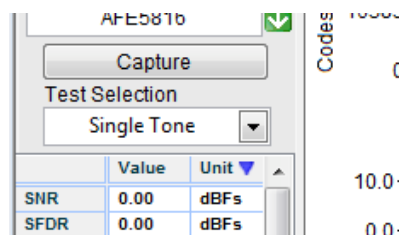

Figure 20. Capture Button

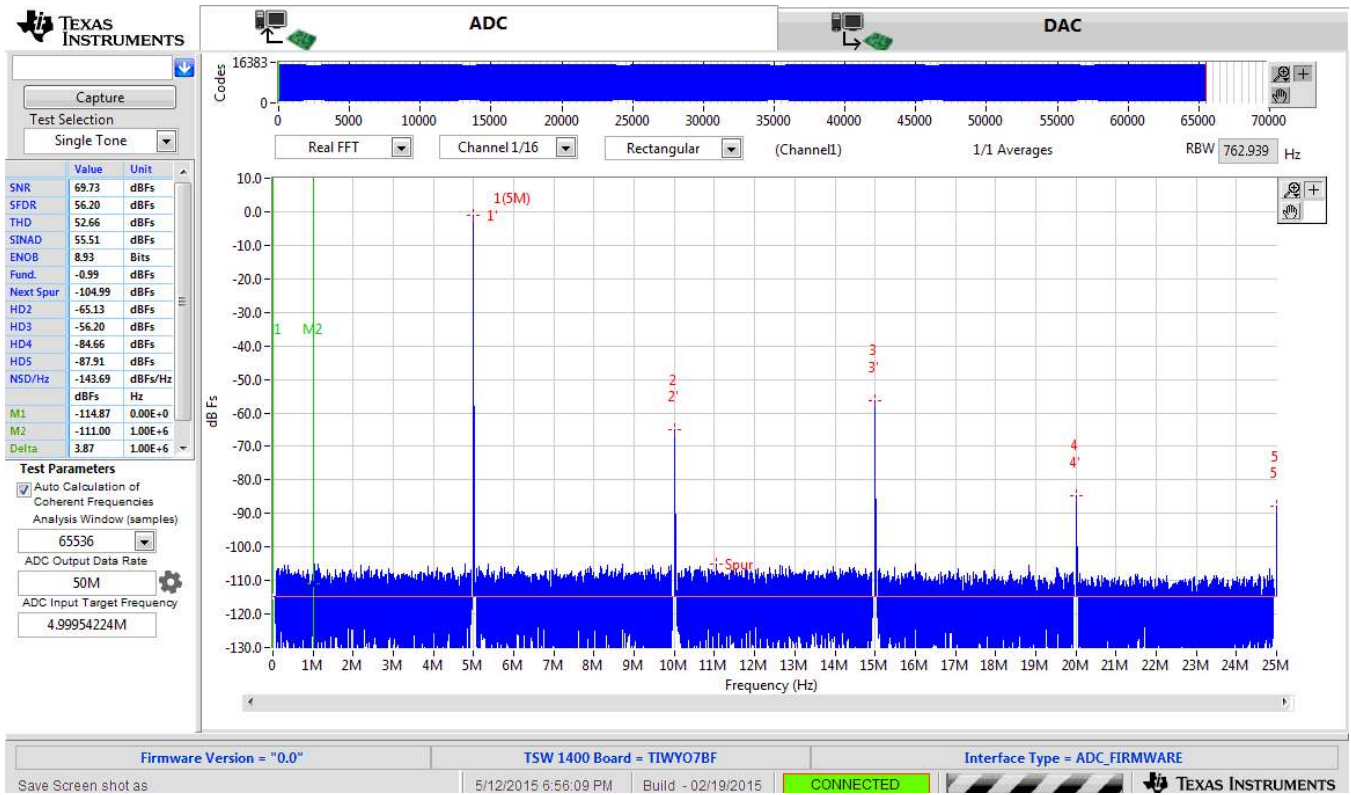

Figure 21. Analog Input Capture

5 Testing the EVM in CW Mode

Demonstrating the CW mixer in the AFE is done by following these steps:

1. In the HMC-DAQ GUI, initialize the device by pressing the *Initialize Device* button.

2. Initialize Device for Data Capture

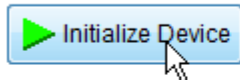

3. Choose Data Format

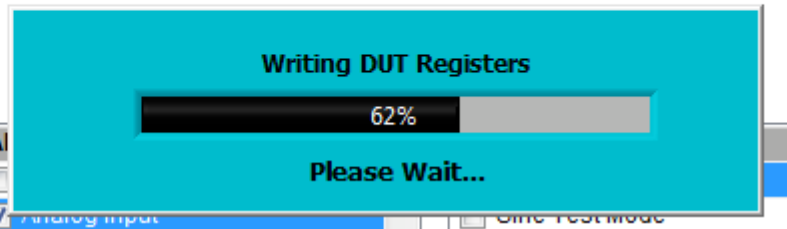
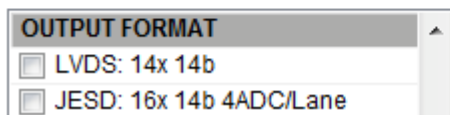

Figure 22. Initialize Device

2. Choose "CW: 16x 1.953 MHz"

3. Choose Data Format

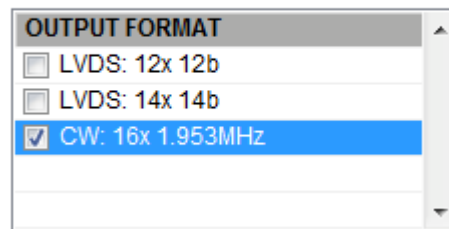

Figure 23. CW Mode Preset

3. Connect a sine wave generator to SMA **J6**, **INP1** or any other channel. Set the frequency to 1.963125 MHz and the amplitude to -20 dBm.
4. Connect two cables to an oscilloscope with timebase $40 \mu\text{s}$ and 500 mV/div . Input resistance should be 50Ω on each scope channel.
5. Connect those two cables to SMAs, J53 and J57.
6. The oscilloscope displays the frequency I and Q signals at 10 kHz as shown in [Figure 24](#). The amplitude should be around $1.3 \text{ Vpp} \pm 200 \text{ mVpp}$, though this amplitude may change. The frequency should be 10 kHz and signals should be 90 degrees out of phase.
7. Trigger the oscilloscope on either channel.

DSO-X 2024A, MY51350471: Mon Dec 08 21:10:22 2014

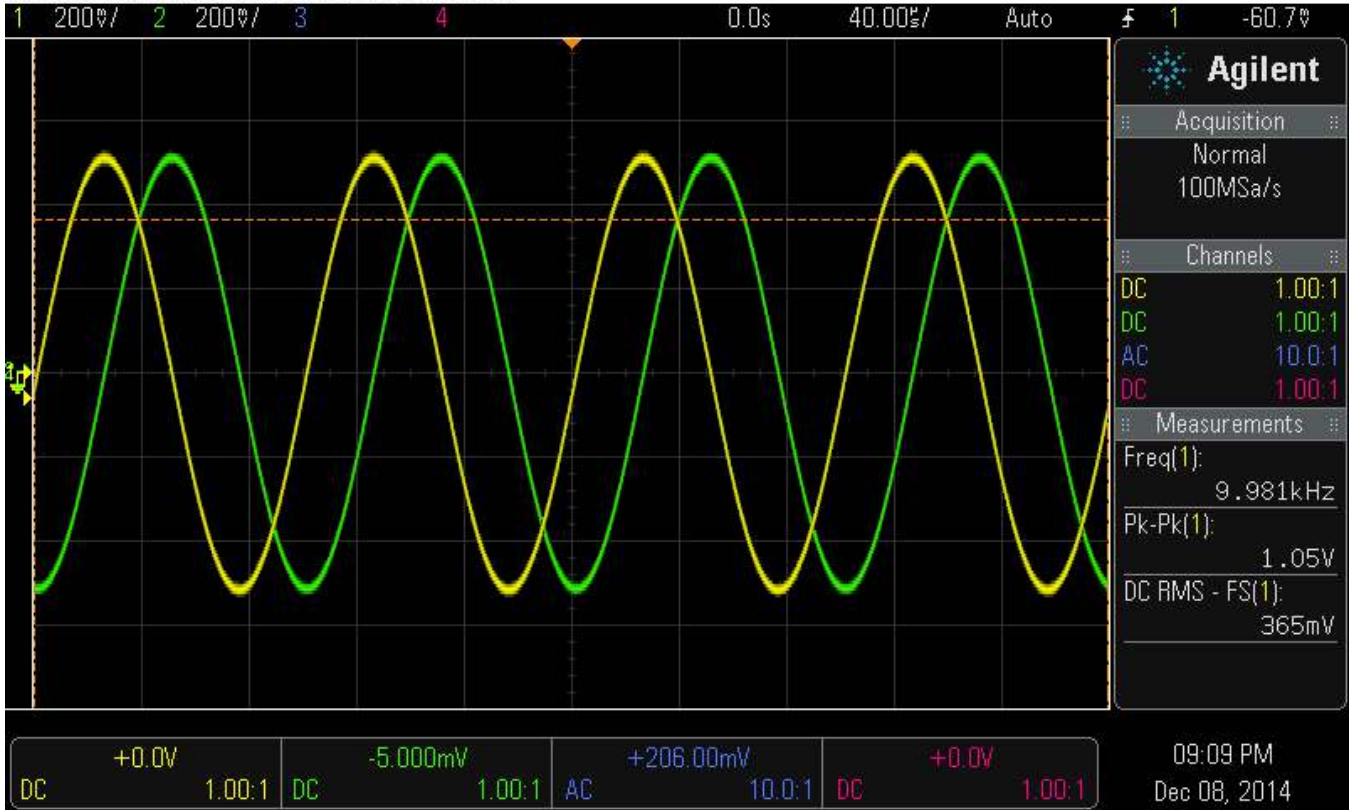

Figure 24. CW Output

Software Installation

[Section A.1](#) provides detailed procedures for installing High Speed Data Converter Pro (HSDCPro), the software GUI used to control a suite of FPGA capture solutions including the TSW1400. [Section A.2](#) provides details for installing Healthtech Multi-Channel Data Acquisition (HMC-DAQ), the software GUI which controls a suite of AFE and ADC solutions, including the AFE5818 .

A.1 High Speed Data Converter Pro (HSDCPro) GUI Installation

Go to the [HSDCPro website](#). Under **Technical Documents**, find the **Software** section and download and save the **High Speed Data Converter Pro GUI Installer** to the local PC hard drive.

1. Unzip the saved file and run the installer executable (*Run as Administrator*) to obtain the menu shown in [Figure 25](#).
2. Click the *Next* button.

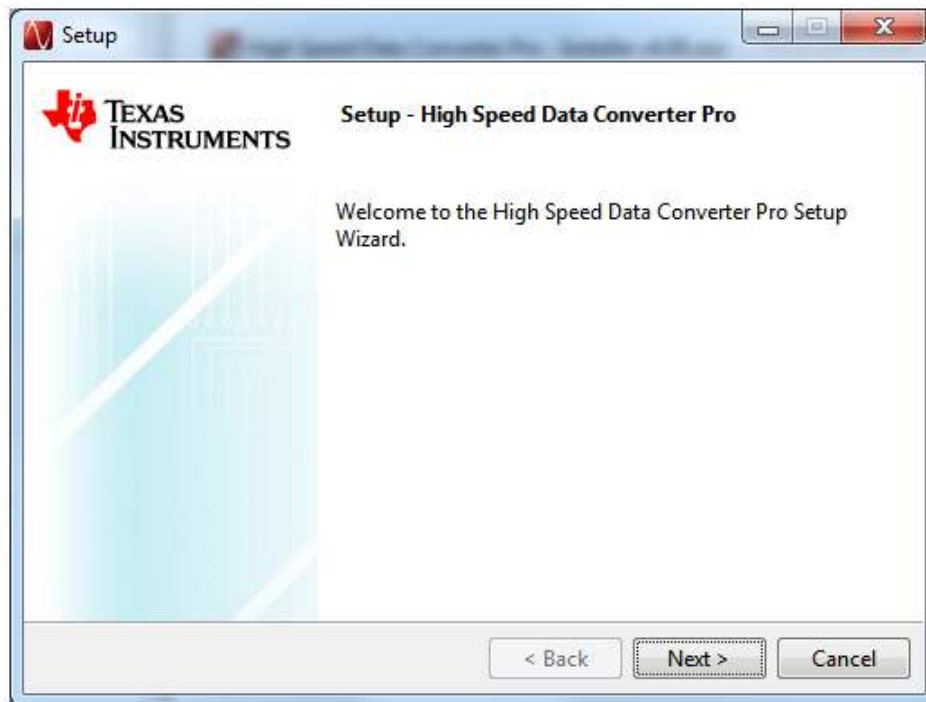

Figure 25. HSDCPro Install (Begin)

3. Read the License Agreement from Texas Instruments and select *I accept the License Agreement*, then press the *Next* button as shown in [Figure 26](#).

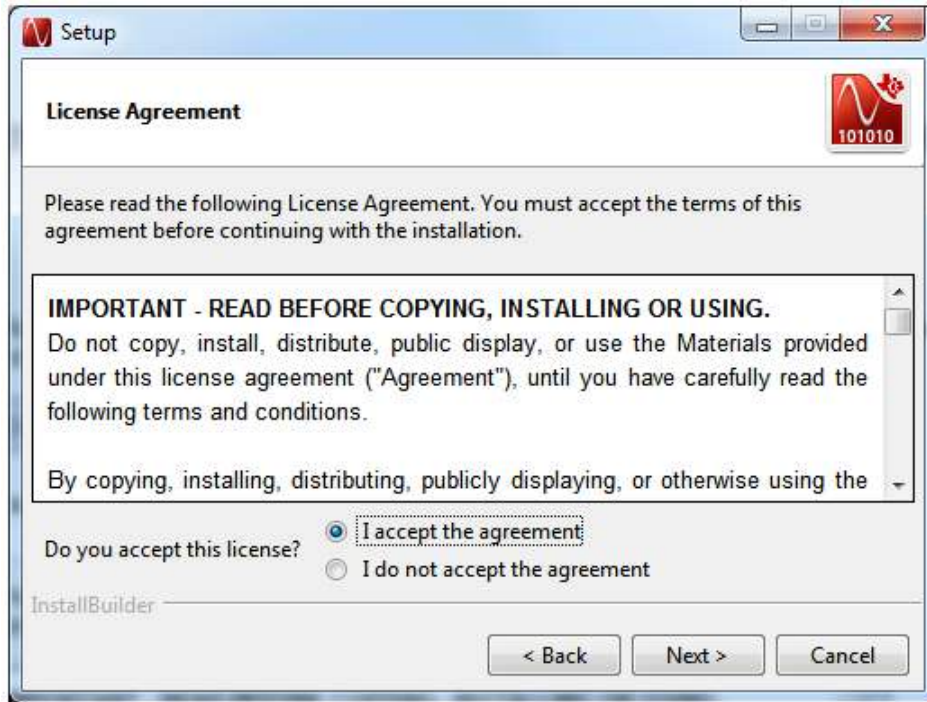

Figure 26. HSDCPro Install (TI License Agreement)

4. Read the License Agreement from Texas Instruments and select *I accept the agreement*, then press the *Next* button as shown in [Figure 27](#).



Figure 27. HSDCPro Install (TI License Agreement)

5. Allow the installation to be placed in the default directory by clicking *Next*, as in [Figure 28](#).

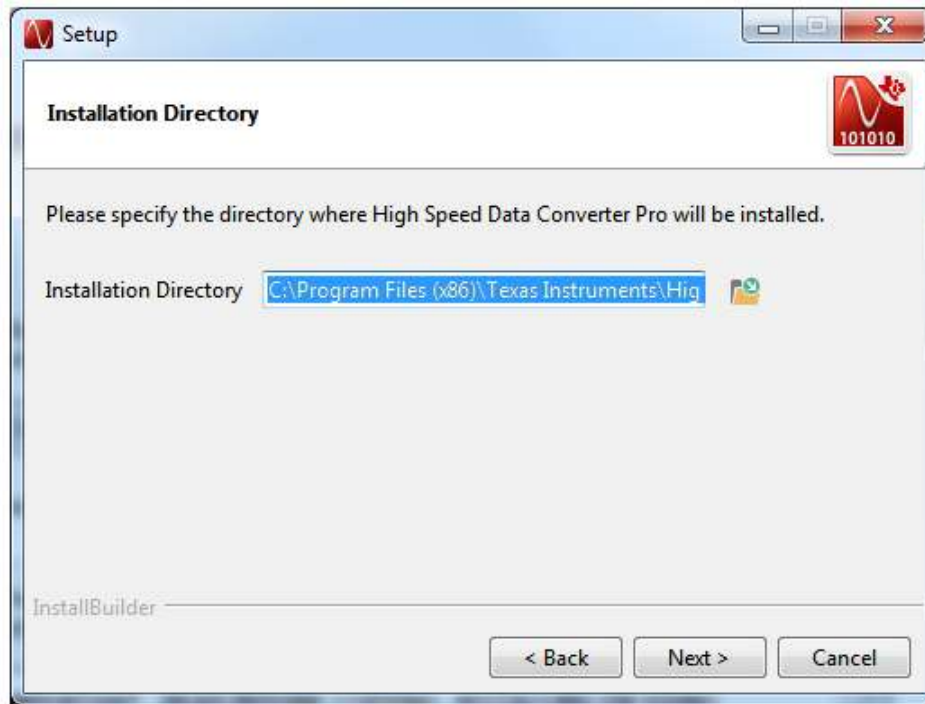

Figure 28. HSDCPro Install (Install Directory)

6. Click *Next* to begin the installation, as in [Figure 29](#).

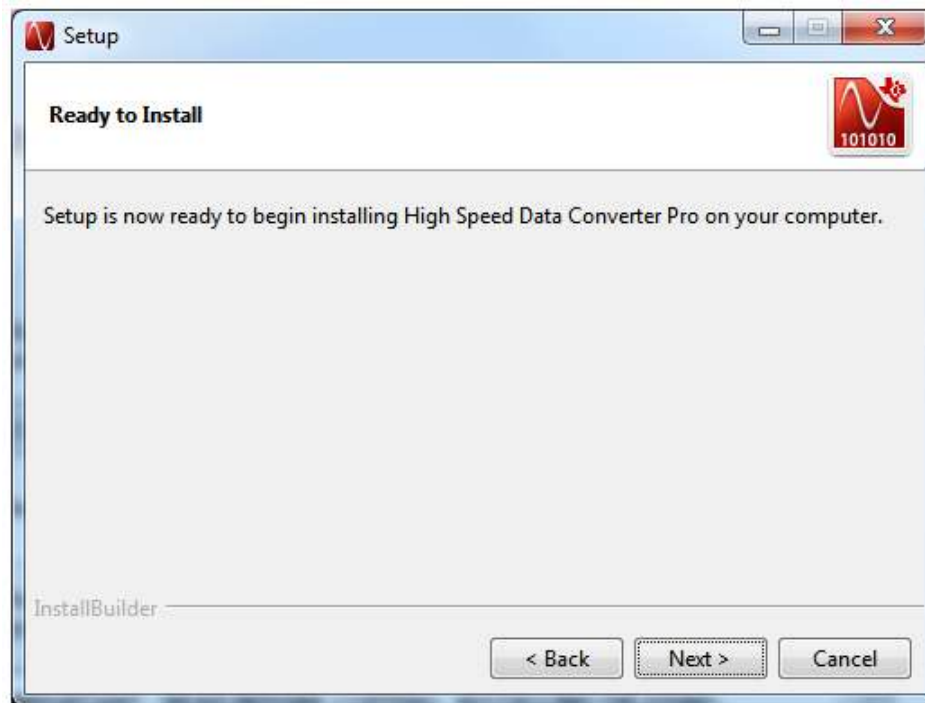

Figure 29. HSDCPro Install (Installation Ready)

- The Cypress Driver begins installing as shown in [Figure 30](#).

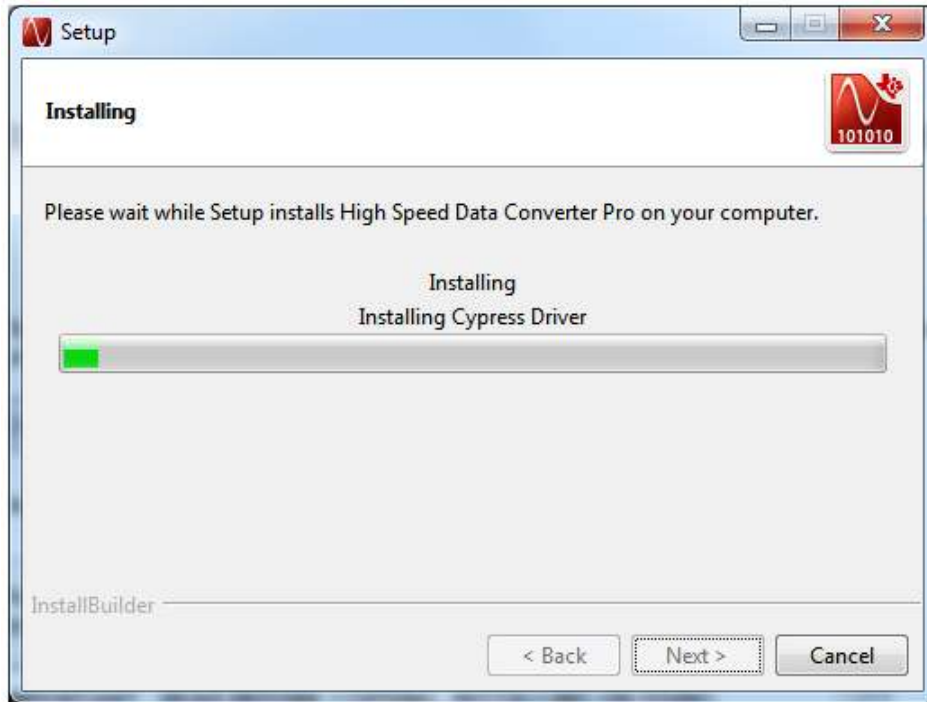

Figure 30. HSDCPro Install (Cypress Driver Install)

- Click *Finish* to continue installation, as shown in [Figure 31](#).



Figure 31. HSDCPro Install (Continue Cypress Driver Installation)

- Continue Driver Installation, as in [Figure 32](#).



Figure 32. HSDCPro Install (Continue Driver Installation)

- Finish HSDCPro installation by choosing the installation options and pressing *Finish*, as in [Figure 33](#).

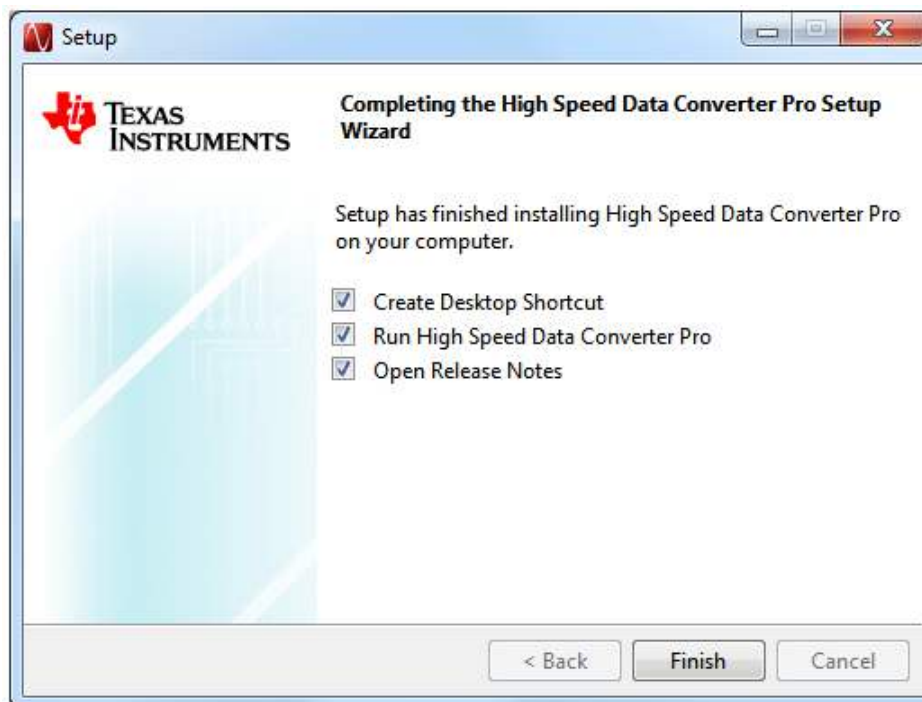

Figure 33. HSDCPro Install (Finish Installation)

A.2 HMC-DAQ GUI Installation

Check the [ti.com](http://www.ti.com) product folder for the relevant device, such as <http://www.ti.com/tool/AFE5818EVM> . Scroll down the page to the *Software* section for the software GUI link.

1. Unzip the saved file and run the installer executable as administrator by right clicking on the file and selecting *Run as Administrator*. Press the *Next* button once the graphic in [Figure 34](#) appears.

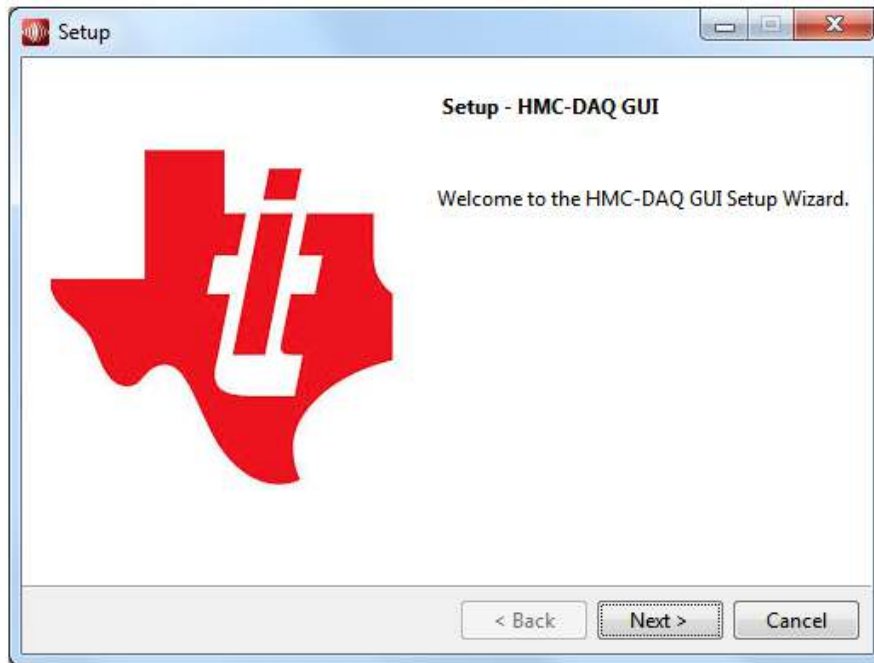

Figure 34. HMC-DAQ GUI Install (Begin Installation)

2. Read the Texas Instruments License Agreement and select *I accept the agreement* followed by the *Next* button, as in [Figure 35](#).

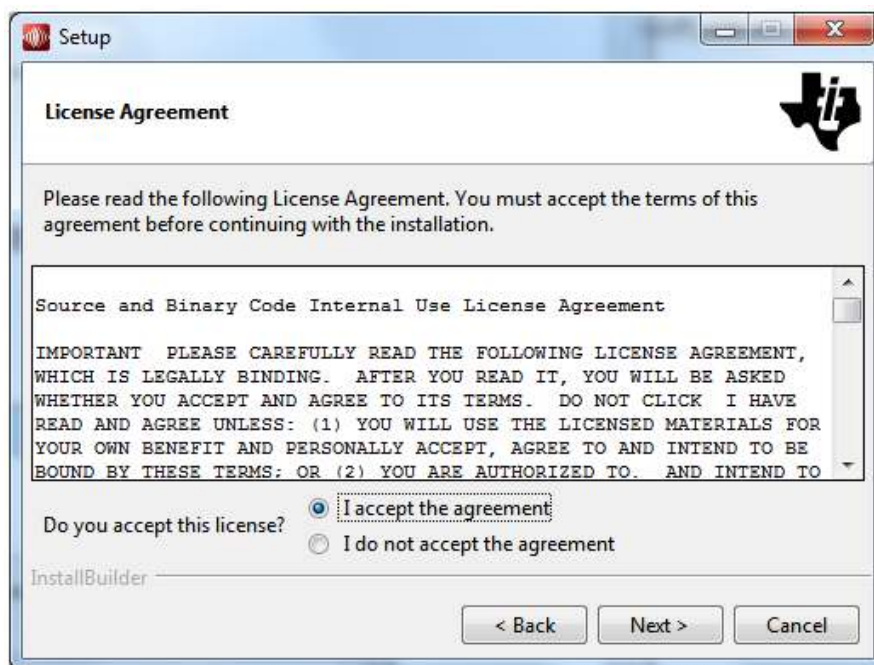

Figure 35. HMC-DAQ GUI Install (TI License Agreement)

3. Read the National Instruments License Agreement and select I accept the agreement followed by the *Next* button, as in [Figure 36](#).

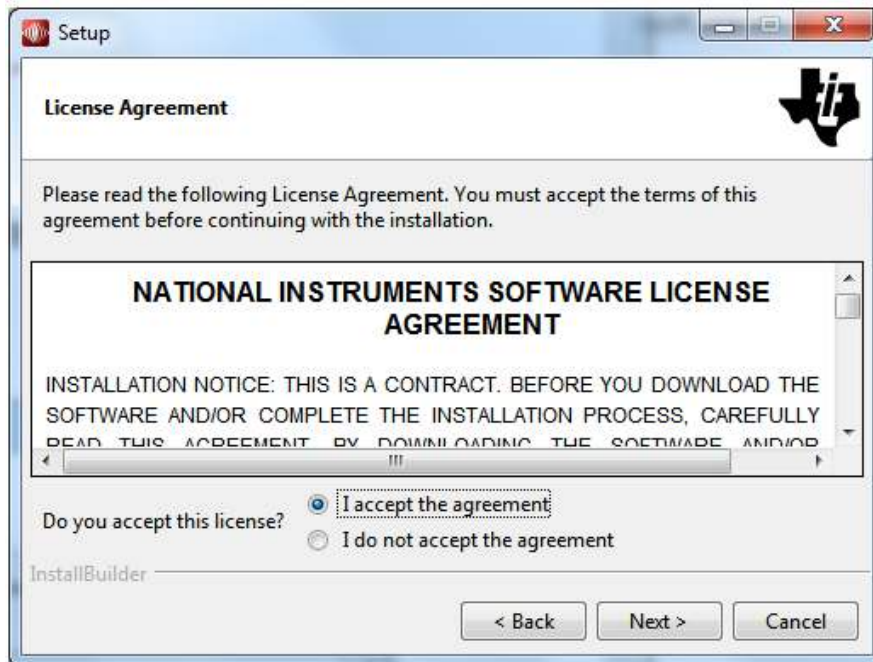

Figure 36. HMC-DAQ GUI Install(NI License Agreement)

4. Allow the software to be installed in the default location by pressing the *Next* button, as in [Figure 37](#).

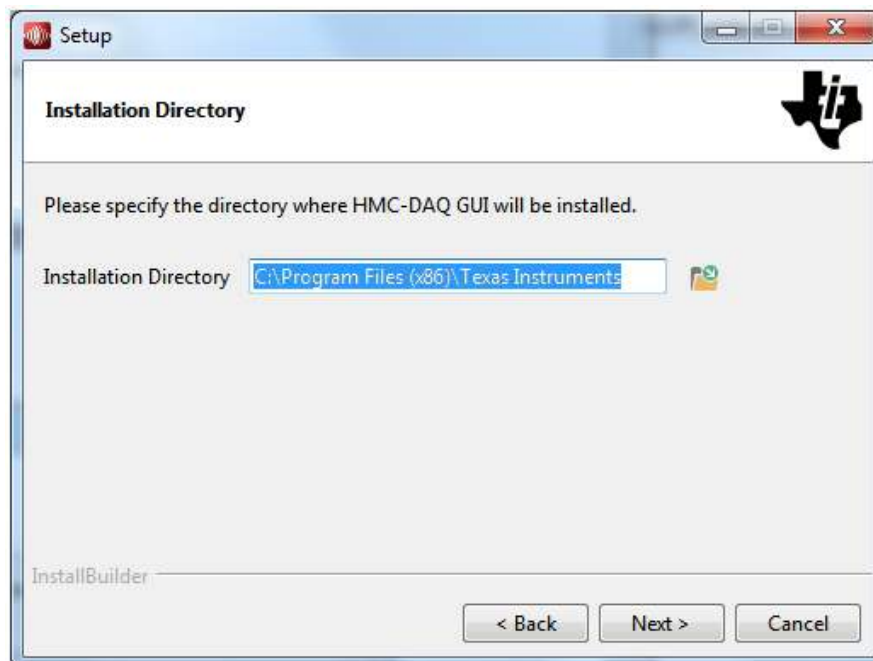

Figure 37. HMC-DAQ GUI Install (Install Directory)

- Pressing the *Next* button begins installation, as shown in [Figure 38](#).

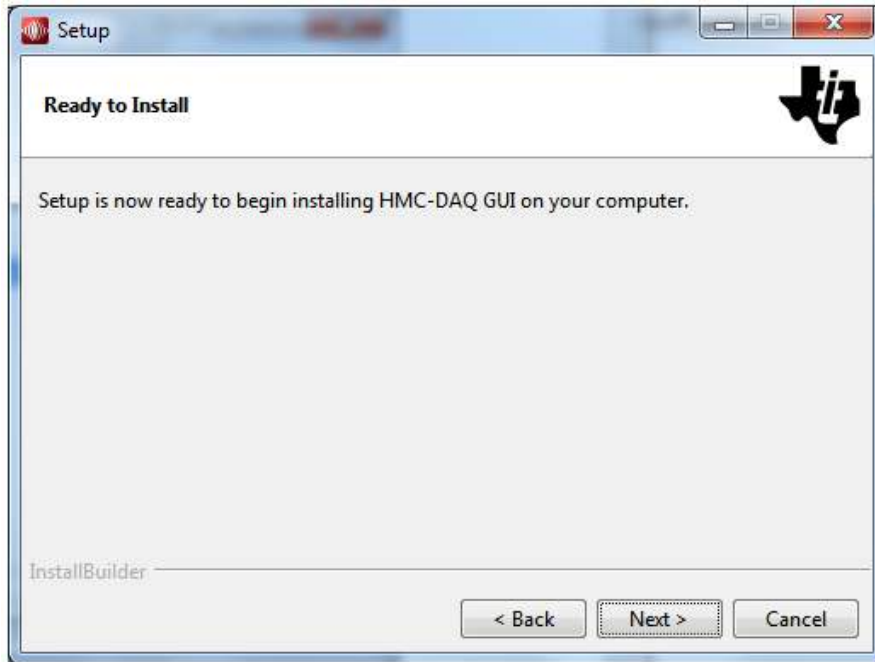

Figure 38. HMC-DAQ GUI Install (Installation Ready)

- The window shown in [Figure 39](#) appears showing that the installation is in progress.

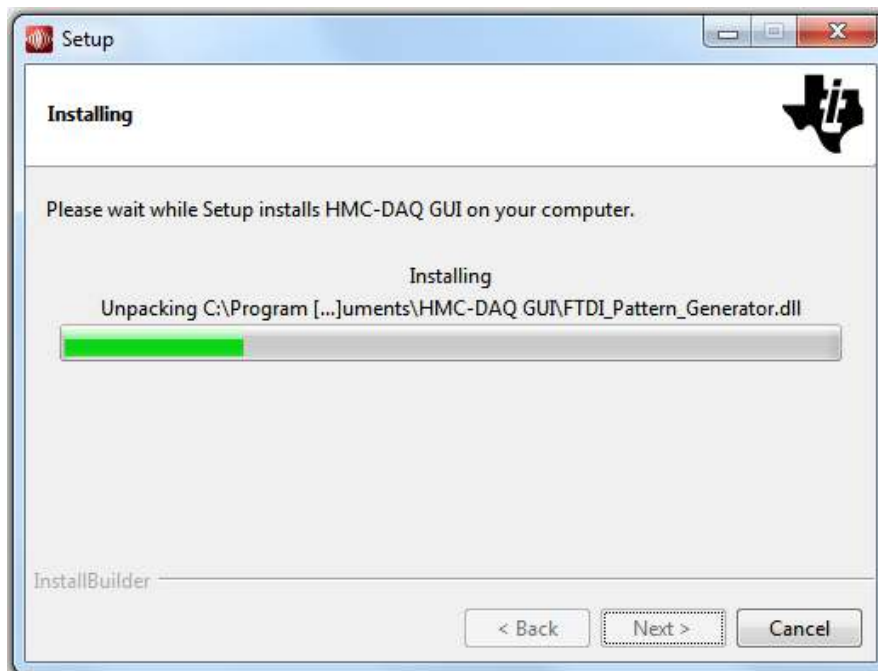

Figure 39. HMC-DAQ GUI Install (Installation Progress)

7. Press the *Next* button to install the required Labview Run Time Engine, as in [Figure 40](#).



Figure 40. HMC-DAQ GUI Install (LabView Run-time Engine Installation)

8. Press the *Next* button, as in [Figure 41](#).

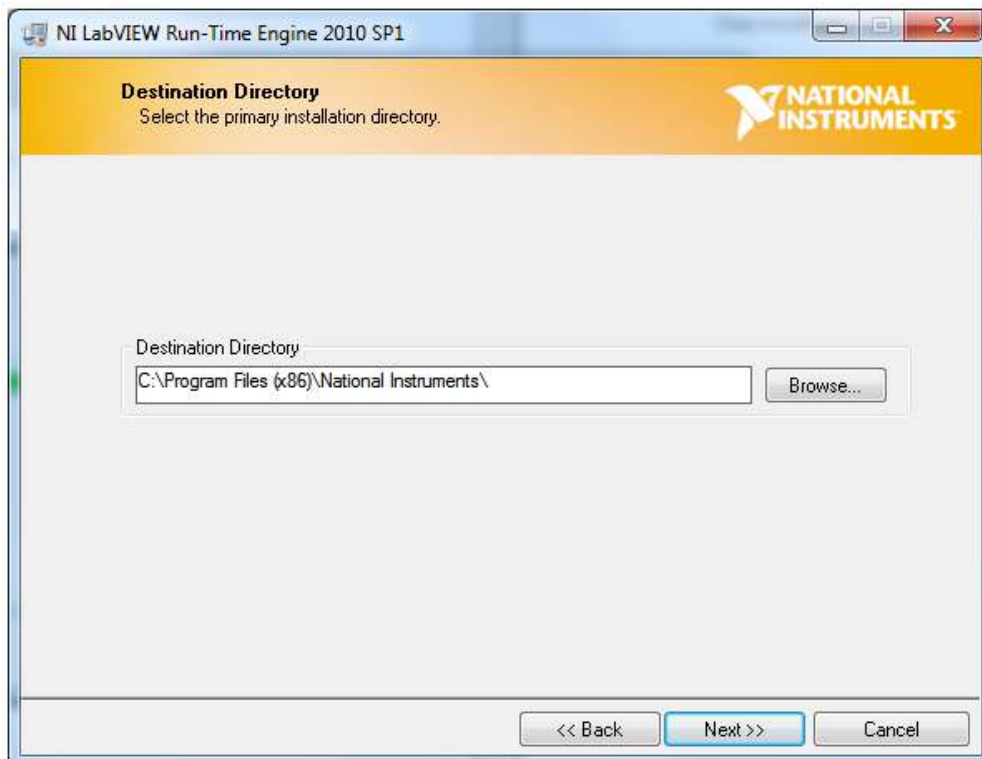

Figure 41. HMC-DAQ GUI Install (LabView Run-time Engine Installation)

9. Press the *Next* button, as in [Figure 42](#).

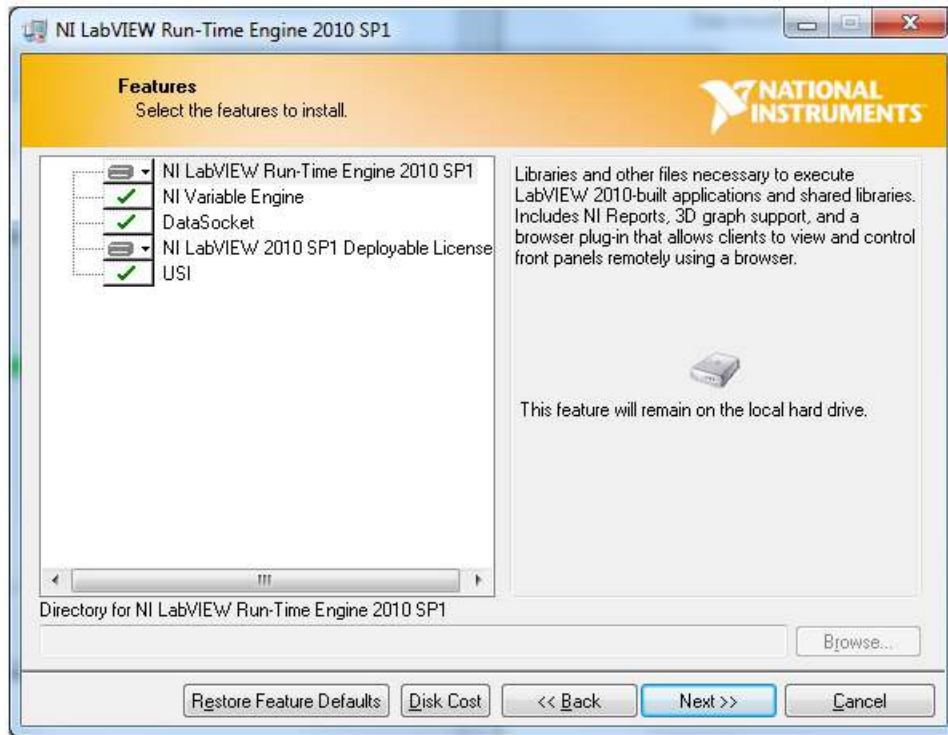

Figure 42. HMC-DAQ GUI Install (LabView Run-time Engine Installation)

10. Press the *Next* button, as in [Figure 43](#).

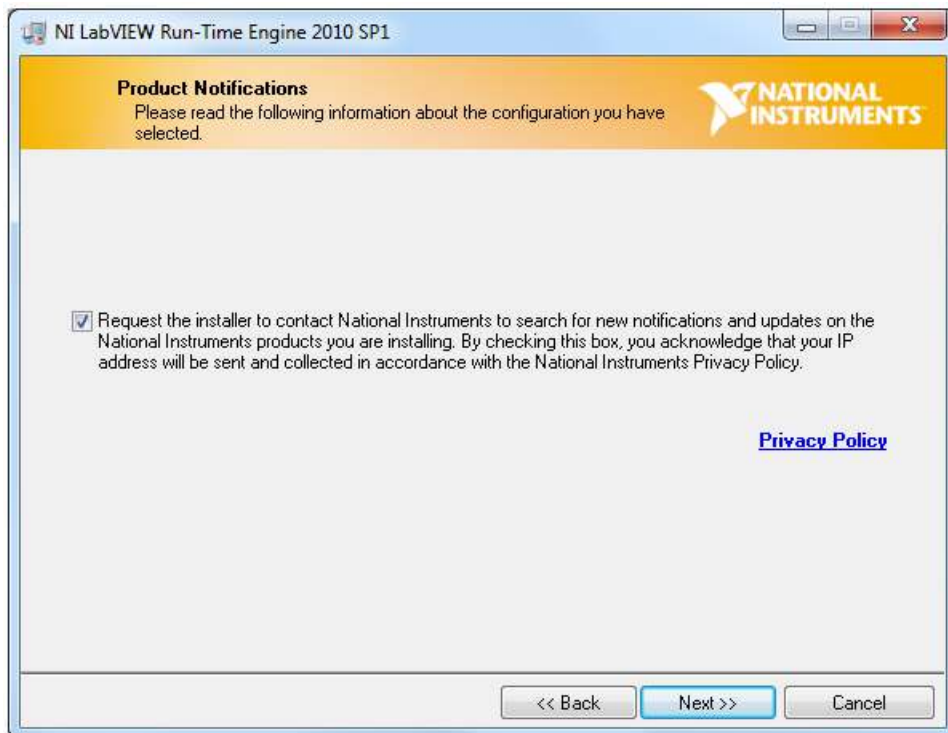

Figure 43. HMC-DAQ GUI Install (LabView Run-time Engine Installation)

11. Press the *Next* button, as in [Figure 44](#).

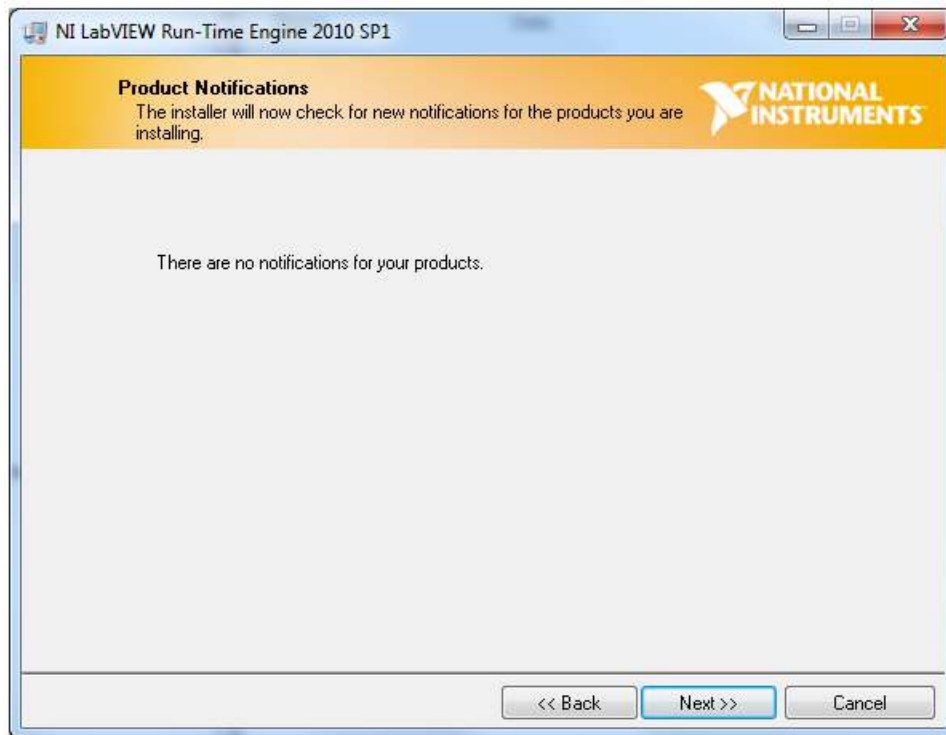

Figure 44. HMC-DAQ GUI Install (LabView Run-time Engine Installation)

12. The run-time engine installs unless it has already been detected as should be the case if the HSDCPro GUI was already installed. In this case, the following message appears. Press the *Cancel* button, as in [Figure 45](#).

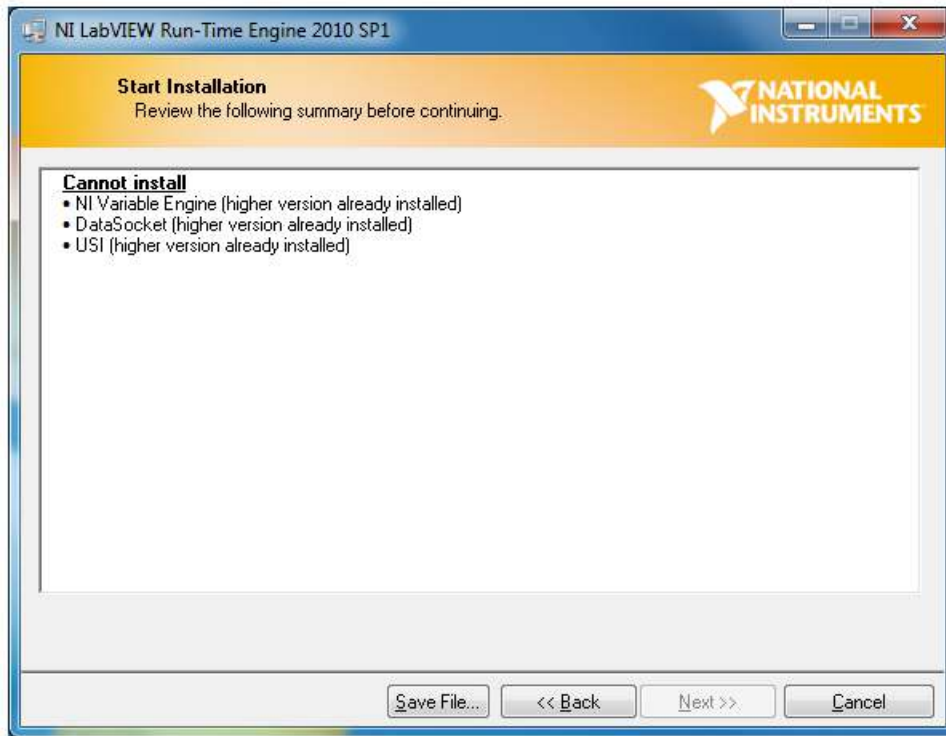

Figure 45. HMC-DAQ GUI Install (LabView Run-time Engine Installation)

13. Press the Yes button to confirm, as in Figure 46.

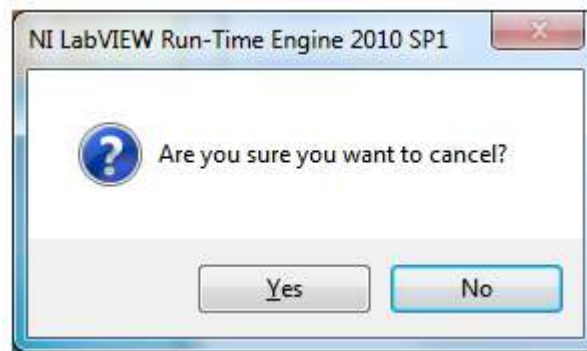

Figure 46. HMC-DAQ GUI Install: (LabView RTE Cancel, if Installed Already)

14. Press the *Finish* button, as in Figure 47.



Figure 47. HMC-DAQ GUI Install (Finished)

HMC-DAQ is launched automatically from HSDCPro, once a device has been selected. Therefore, there is no need to launch HMC-DAQ manually and there is no need for a desktop shortcut.

Hardware Configuration

B.1 EVM Headers, Test Points, and Configuration

This section describes the functions of the headers on the EVM. It also provides a list of test points on the EVM that are useful for debug and general-use purposes.

B.1.1 EVM Header Configuration

The AFE5818 EVM is flexible in its configurability through the use of 2- and 3-pin headers. The default configuration of the EVM is set to facilitate initial testing, requiring minimal bench equipment. [Figure 48](#) shows the default positions of all headers.

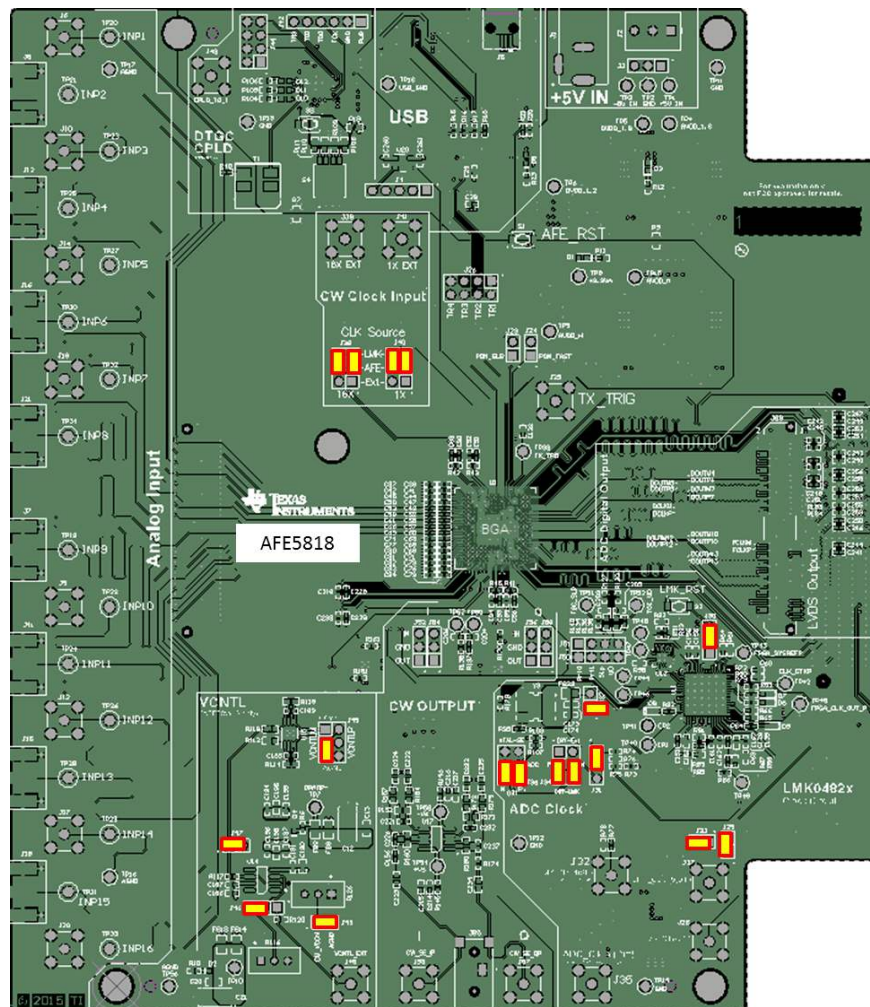

Figure 48. Default Jumper Positions

Table 1 lists the default header configurations and descriptions.

Table 1. Default Header Configuration Table Rev.C

Jumper	Circuit	Description	Pin Numbers	Selection
J3	Power Supply	±5V Input Power Connector	-	-
J4	USB/SPI	SPI Signals Probe Point	-	-
J23	PDN	PDN_Global	-	-
J24	PDN	PDN_Fast	-	-
J37	ADC Clock	OSC1 Xtal Power supply +3.3VD	1-2	3.3V
J36	ADC Clock	Clk source selector for SE Xtal or Diff	2-4,1-3	Differential
J34	ADC Clock	Diff CLK Source selector, Ext Xfmr or LMK	3-5, 4-6	LMK CLK
J38	CW CLK	16x CLK Source Selector	1-2	Ext
J40	CW CLK	1x CLK Source Selector	1-2	Ext
J50	DTGC	DTGC Digital Input Signals	-	-
J51	DTGC	GND for Dig Input Signals	-	-
J42	DTGC	CPLD JTAG Programming Header	-	-
J44	DTGC	CPLD GPIO	-	-
J30	LMK	LMK Chip Reset	-	-
J29	LMK	LMK Supply for 125M Xtal	-	-
J33	LMK	PS for 100 MHz VCO	1-2	3.3V
J31	LMK	Input Clk selector for Clkin1 (xtal/J32 SMA)	1-2	125 MHz Xtal
J45	Vcntl	Vcntl AFE pin selector, GND or Amp	2-3	Amp
J46	Vcntl	Vcntl Amp voltage source, pot or SMA	2-3	Pot
J47	Vcntl	SE-to-Diff Amp Bypass	1-2	Bypassed
J49	Vcntl	Vcntl Amp CM voltage to GND	-	-
J26	LNA TR Enable	TR_EN 1-4	-	-
J52/54	CW Output	CW In-phase Output M/P	-	-
J56/58	CW Output	CW Quadrature-phase Output M/P	-	-

B.1.2 EVM Testpoints

Table 2 lists all test points on the AFE5818 EVM and their purposes.

Table 2. EVM Rev.C Testpoints

Testpoint	Circuit	Label	Testpoint Description
TP2,11-14	GND	GND	Digital Ground Reference for EVM
TP16,17,56	GND	AGND	Analog Ground Reference for EVM
TP18	GND	USB_GND	USB Ground Reference for EVM
TP1	Power Supply	+5V_IN	+5V_IN
TP3	Power Supply	-5V_IN	-5V supply for Op-Amp circuitry
TP4	Power Supply	AVDD_1.8	AFE +1.8V analog supply
TP5	Power Supply	DVDD_1.8	AFE +1.8V digital supply
TP6	Power Supply	DVDD_1.2	AFE +1.2V digital supply
TP7	Power Supply	OPAMP-	-5V Supply for Vcntl circuit
TP8	Power Supply	+3.3VA	+3.3VA
TP9	Power Supply	AVDD_H	AFE analog supply for 5V or 3.3V
TP10	Power Supply	None	+5V Supply for Op Amp circuitry
TP15	Power Supply	AVDD_M	AFE analog supply for 1.9V or 3.3V
TP36	Power Supply	+Vs	+5V Supply for CW Op Amp circuitry
TP37	Power Supply	-Vs	-5V Supply for CW Op Amp circuitry
TP19-34	Analog Inputs	INPx	Analog Input Channel 1-16
TP39	DEMODO	TX_TRG	TX_Trig input
TP52	DTGC	None	Ext TGC_Profile2 Input
TP50	DTGC	None	Ext TGC_Profile1 Input

Table 2. EVM Rev.C Testpoints (continued)

Testpoint	Circuit	Label	Testpoint Description
TP51	DTGC	TGC_SLP	Ext TGC_Slope
TP35	DTGC	TGC_UD	Ext TGC_Up/Down
TP40,41	LMK Clock Circuit	CP1,CP2	LMK Output CP1,CP2
TP42	LMK Clock Circuit	CLK_GTXP	LMK GTX CLK to FPGA P
TP43	LMK Clock Circuit	FPGA_SYSREF P	LMK SYSREF CLK to FPGA P
TP44,46	LMK Clock Circuit	None	LMK ADC Clock to Dut P/N
TP45,47	LMK Clock Circuit	None	LMK SYSREF Clock to Dut P/N
TP48	LMK Clock Circuit	FPGA_CLK_OUT_P	LMK ADC CLK to FPGA P
TP49	LMK Clock Circuit	None	LMK VCXO output

B.1.3 ADC Clock Source Configuration

The AFE clock input can be driven differentially (sine wave, LVPECL, or LVDS) or single-ended (LVCMOS). The clock input of the device has an internal buffer and clock amplifier which is enabled or disabled automatically, depending on the type of clock provided (auto detect feature). Therefore, the EVM allows for two options of clock input for LVDS mode (S-E and Differential), and two options of clock input for JESD204B mode (Differential).

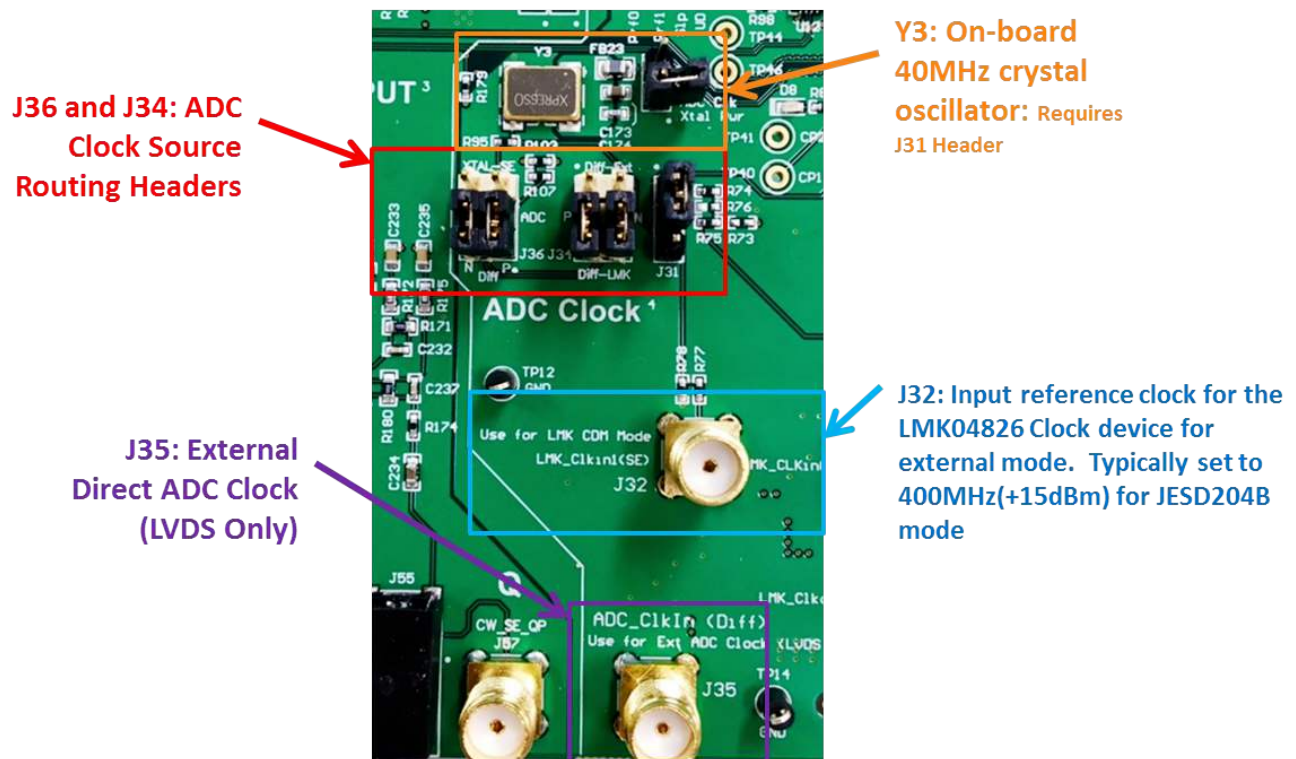

Figure 49. EVM ADC Clock Source Configuration

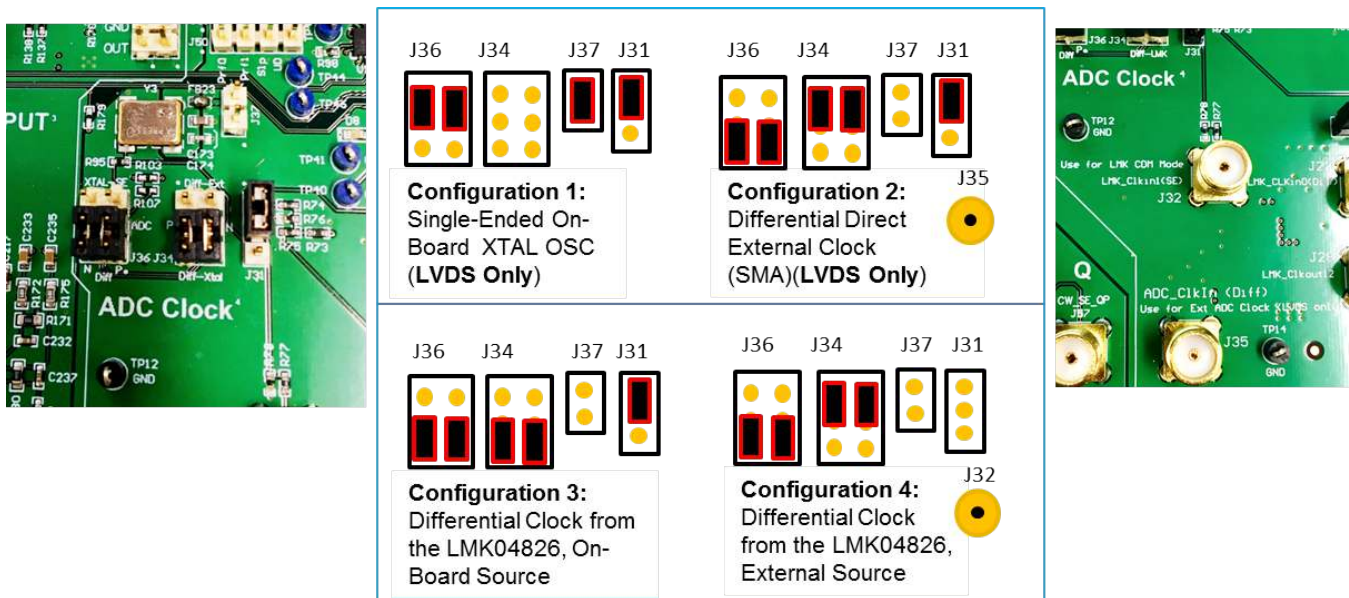

Figure 50. EVM ADC Clock Source Configuration Examples

Configuration 1 (LVDS Only): To use the on-board single-ended crystal oscillator as the clock source for the AFE, connect shunt jumpers for configuration 1 (as seen in [Figure 50](#)). Use this configuration for LVDS Data output only, not JESD204B. Note: J37 powers the on-board oscillator with 3.3 V, due to the power limitations of the VCC1-3B3-40M0000 low-jitter crystal oscillator. The recommended ADC clock input for new designs is to use low-jitter square signals (LVCMOS levels, 1.8-V amplitude.)

Configuration 2 (LVDS Only): To use the differential direct external clock as the clock source for the AFE, connect shunt jumpers for configuration 2. Use this configuration for LVDS Data output only, not JESD204B. Also, connect a single-ended external clock generator to SMA J35. Set the clock source to an appropriate frequency, such as 10 MHz to 80 MHz, and +15-dBm amplitude.

Configuration 3 (Default): This mode uses an on-board crystal to stimulate the LMK04826 in Dual-PLL mode. To use the differential outputs from the LMK04826 as the clock source for the AFE, connect shunt jumpers for configuration 3. Ensure that jumper J29 is installed.

Configuration 4: This mode uses an external generator at J32 to stimulate the LMK04826 in Clock Distribution mode. To use the differential outputs from the LMK04826 as the clock source for the AFE, connect shunt jumpers for configuration 4. Also, connect an external clock generator to J32. Set the clock source to 400 MHz, and +15-dBm amplitude. Consult a TI engineer to use this mode.

Triggering Options

Software Trigger

One method of triggering the TSW EVM, AFE EVM as well as other bench equipment such as function generators is to generate the trigger from the TSW EVM itself. This requires a feedback loop from the TSW trigger output to the TSW trigger input using a short SMA cable. Secondly, a second trigger output from the TSW board can be routed to the AFE EVM, if needed, or to external bench equipment such as a function generator. See the TSW or HSDCPro manual for more information.

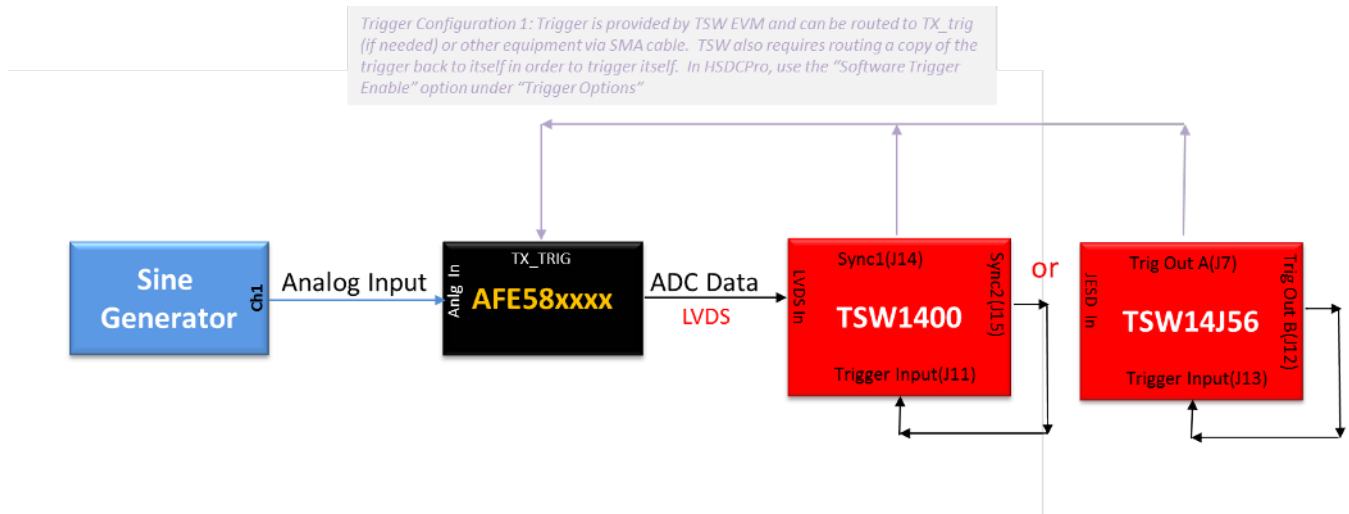

Figure 51. HSDCPro Trigger Configuration for SW

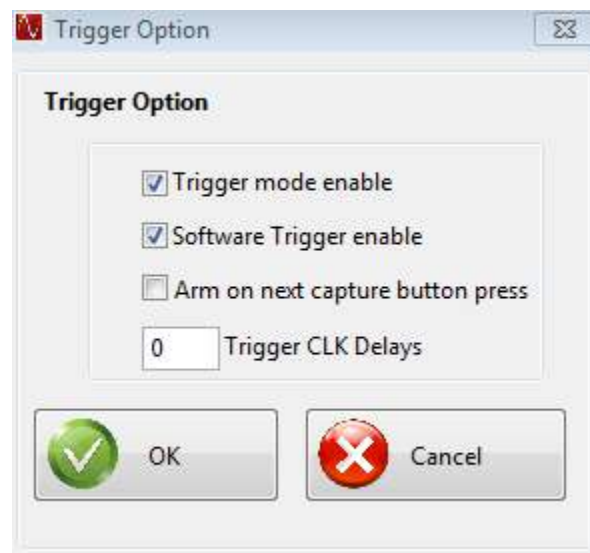

Figure 52. HSDCPro Trigger Configuration for SW trigger

External Trigger

Another method of triggering the TSW EVM and AFE EVM as well as other bench equipment such as function generators is to generate the trigger from a bench trigger source such as the function generator. This requires feeding the trigger source to the TSW trigger input using an SMA cable. Secondly, a second trigger output from the trigger source can be routed to the AFE EVM, if needed. See the TSW or HSDCPro manual for more information.

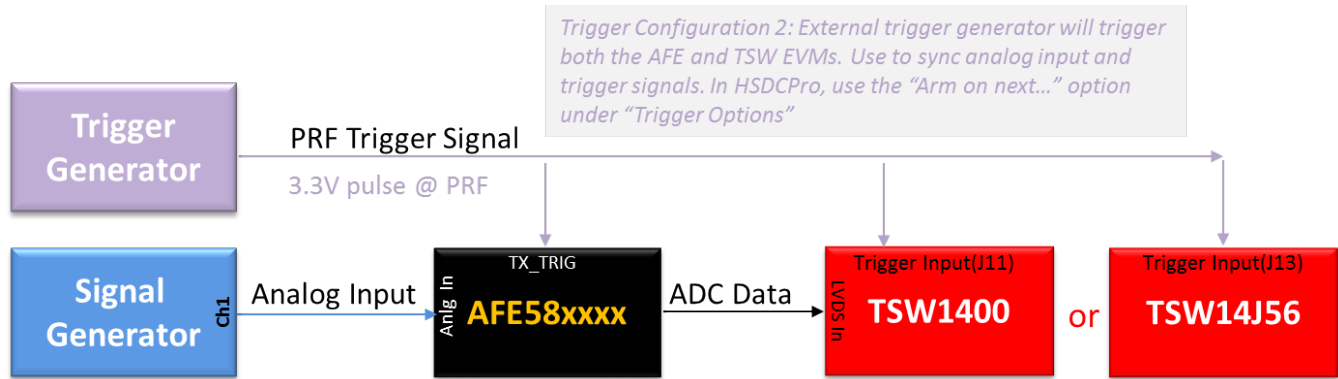

Figure 53. HSDCPro Trigger Configuration for HW

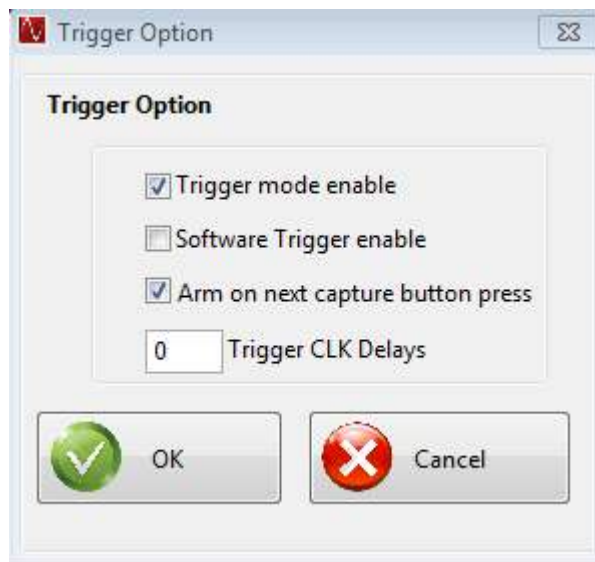

Figure 54. HSDCPro Trigger Configuration for HW External Trigger

Common Hardware Modifications

Low Frequency Support

For low-frequency applications, such as SONAR, that require bandwidth below 200 kHz, the default assembly of the EVM results in attenuation in this range, and the EVM requires hardware modification. Simply change all INP and INM capacitors on the LNA inputs to 1 μ F (0402). Also, set the internal HPF in the AFE to the lowest setting. This should support a bandwidth as low 50 kHz, or lower.

External SPI Programming

The AFE EVM allows for external access to the SPI bus for the AFE only, not the LMK device. This is done by connecting SPI signals at J4 and removing R22 near U9 on the bottom side of the board.

Hardware Reference

E.1 AFE5818 EVM Hardware Overview

The following images give an overview illustration of the EVM hardware.

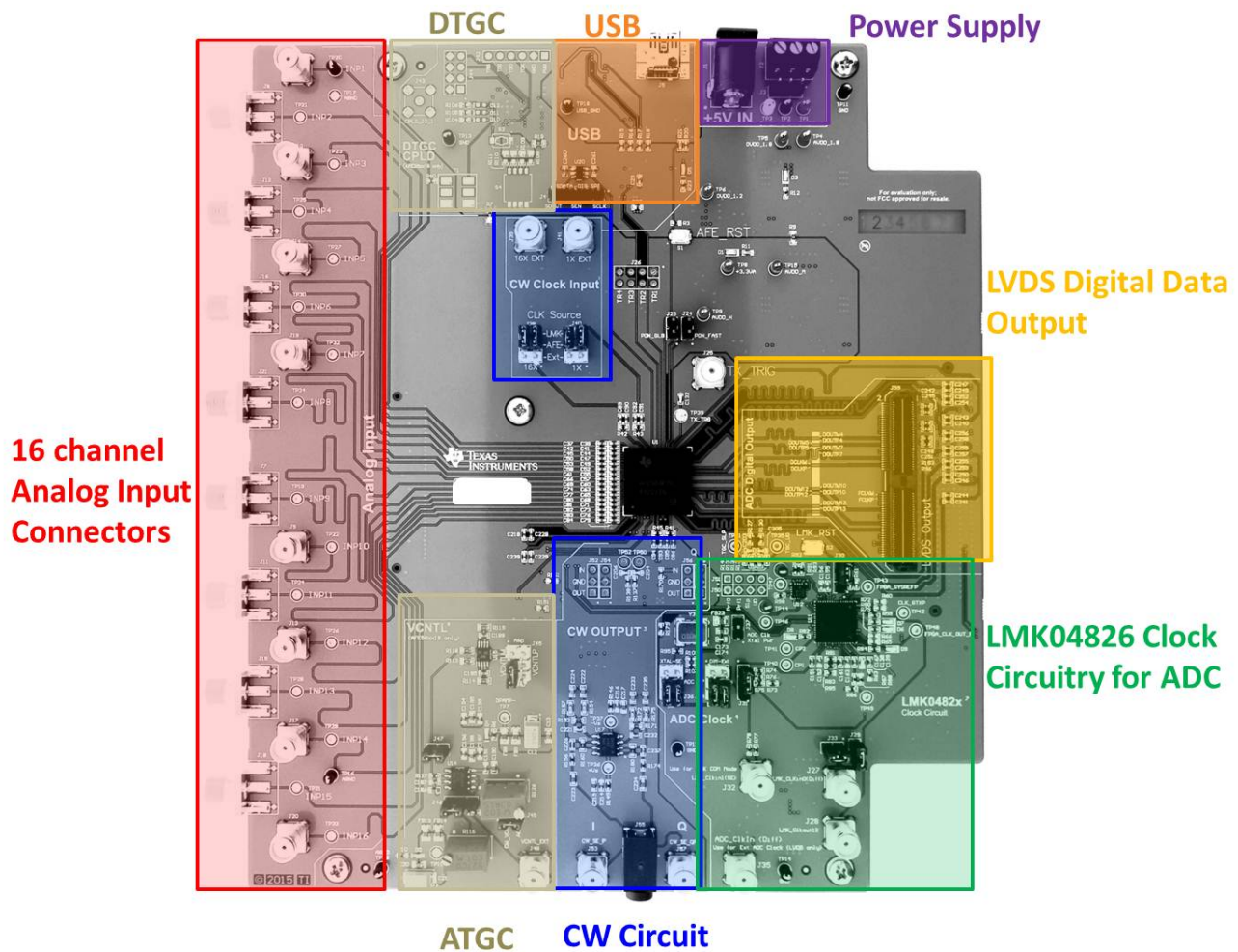

Figure 55. AFE5818 EVM Circuits Map

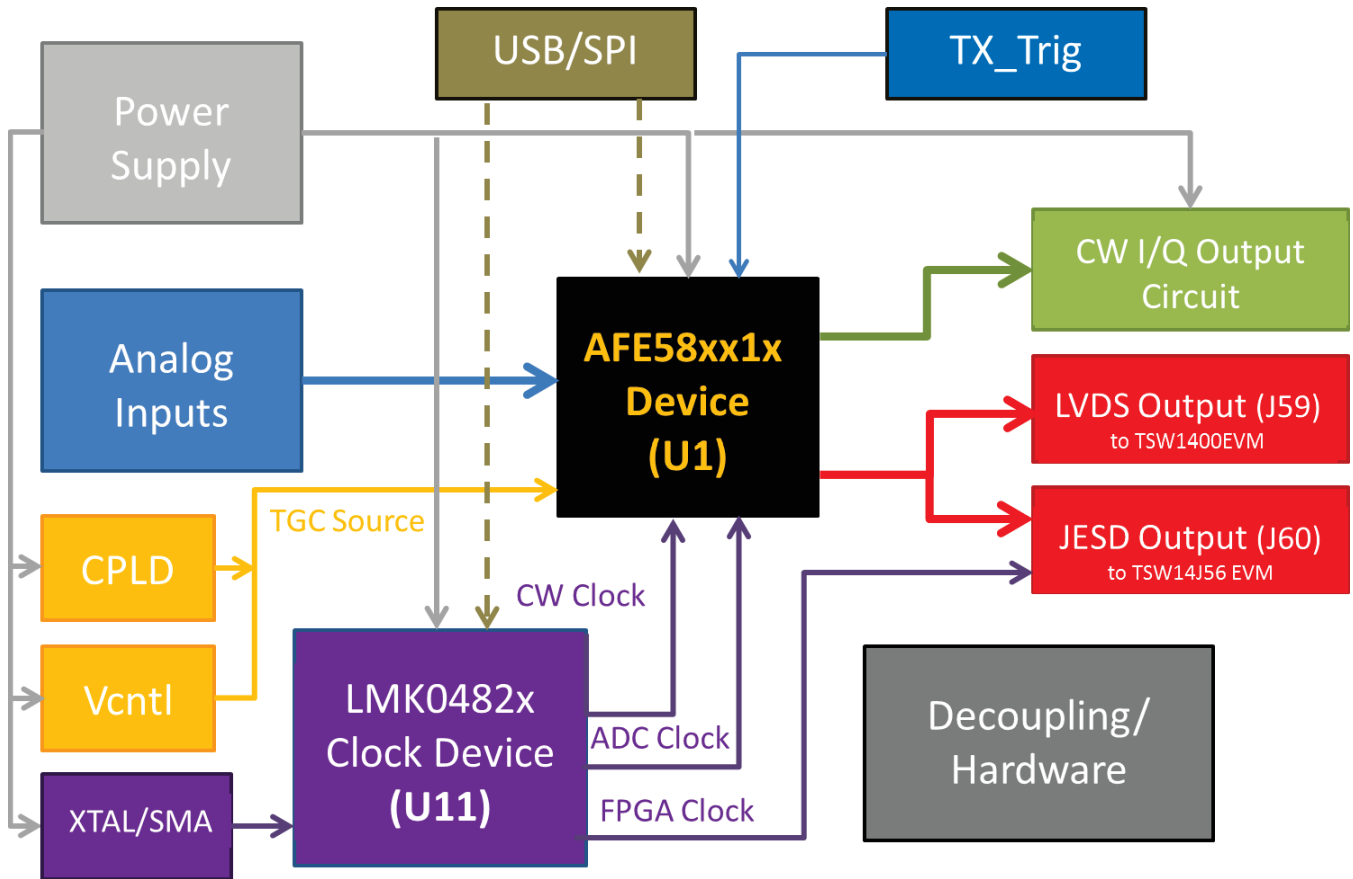

Figure 56. AFE5818 EVM Block Diagram

E.2 AFE5818 EVM Schematic

Figure 57 through Figure 67 illustrate the EVM schematics.

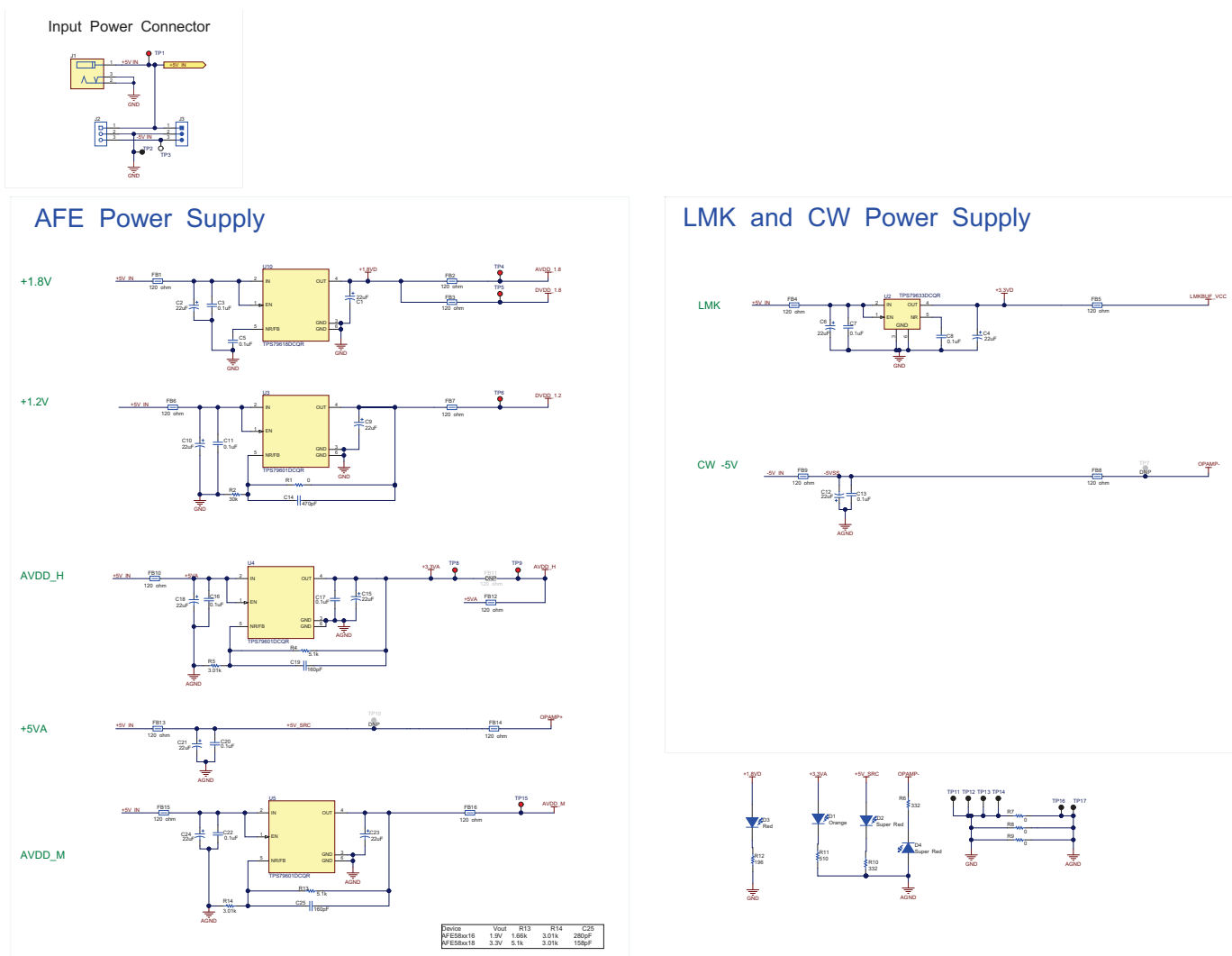
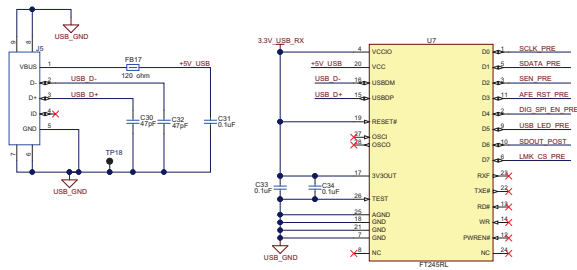

Figure 57. AFE5818 Rev C EVM Schematic 1 of 11

USB

USB Connector and FTDI Port



Digital Isolator

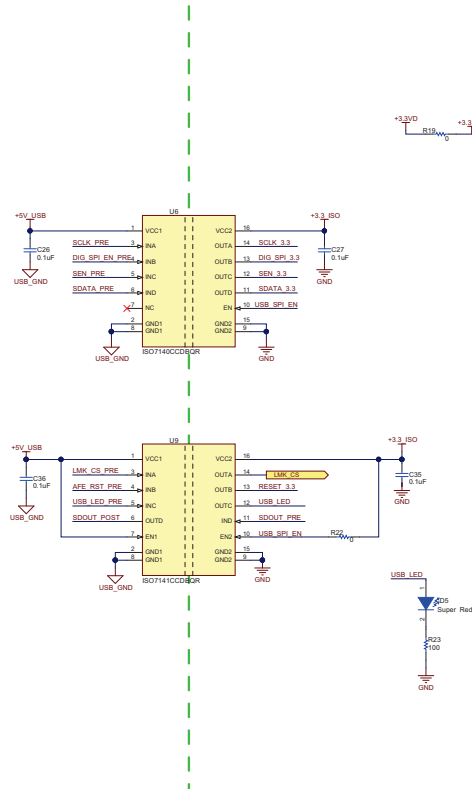

Level Translator

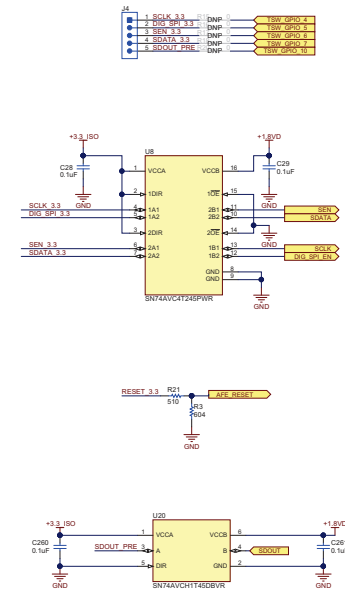
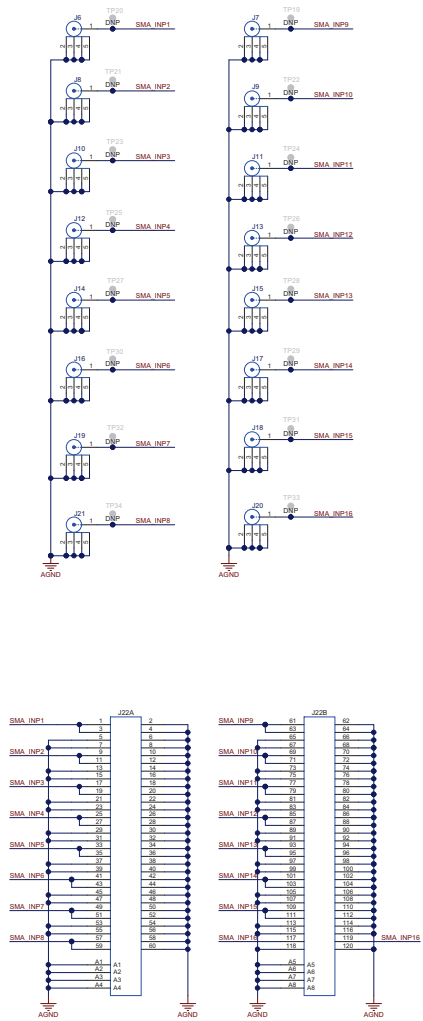
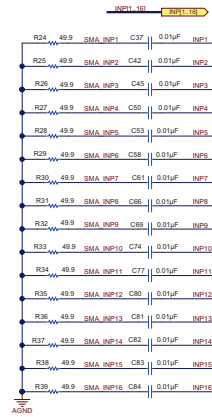

Figure 58. AFE5818 Rev C EVM Schematic 2 of 11

ANALOG INPUTS



INP Caps



INM Caps

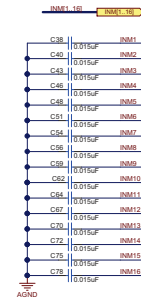

ACT Caps (AFE58xx18 only)

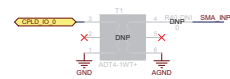
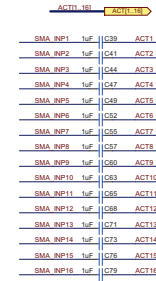

Figure 59. AFE5818 Rev C EVM Schematic 3 of 11

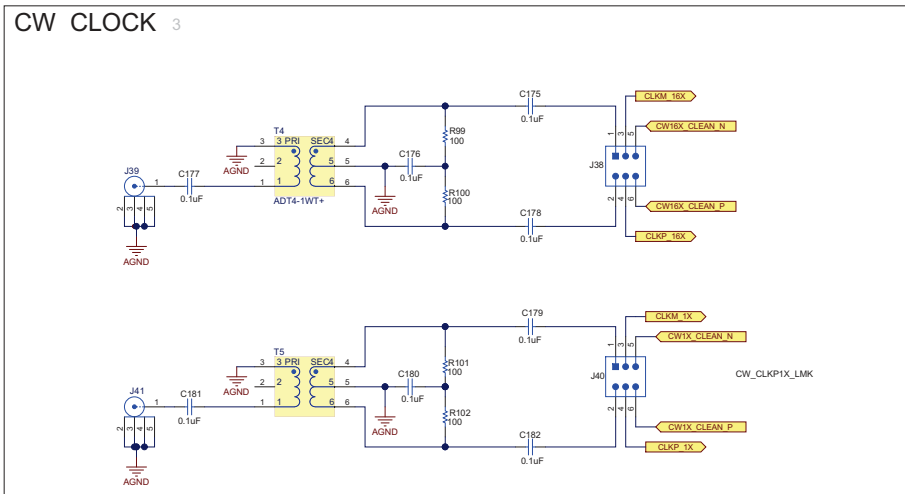
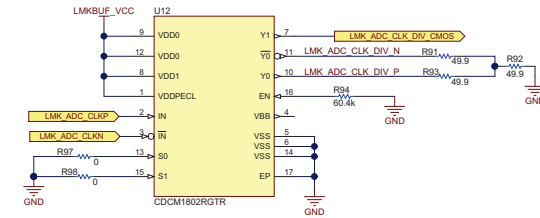
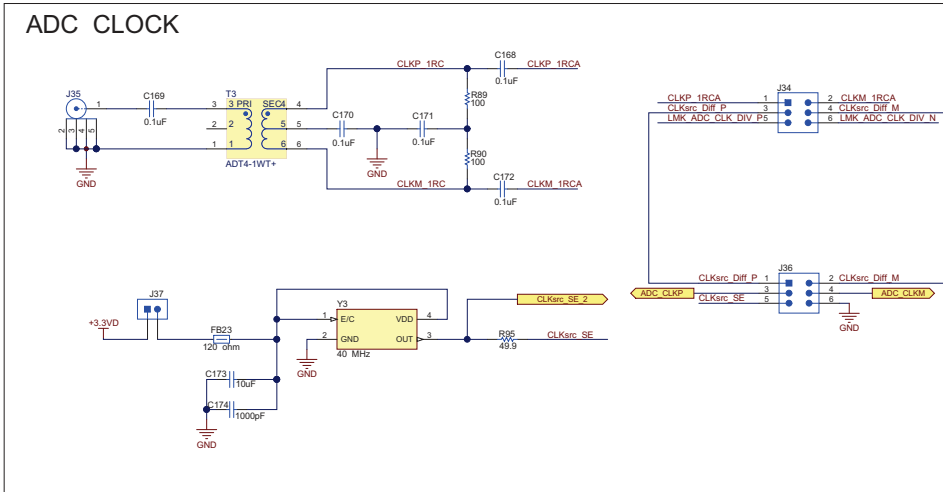

Figure 60. AFE5818 Rev C EVM Schematic 4 of 11

LMK0482x

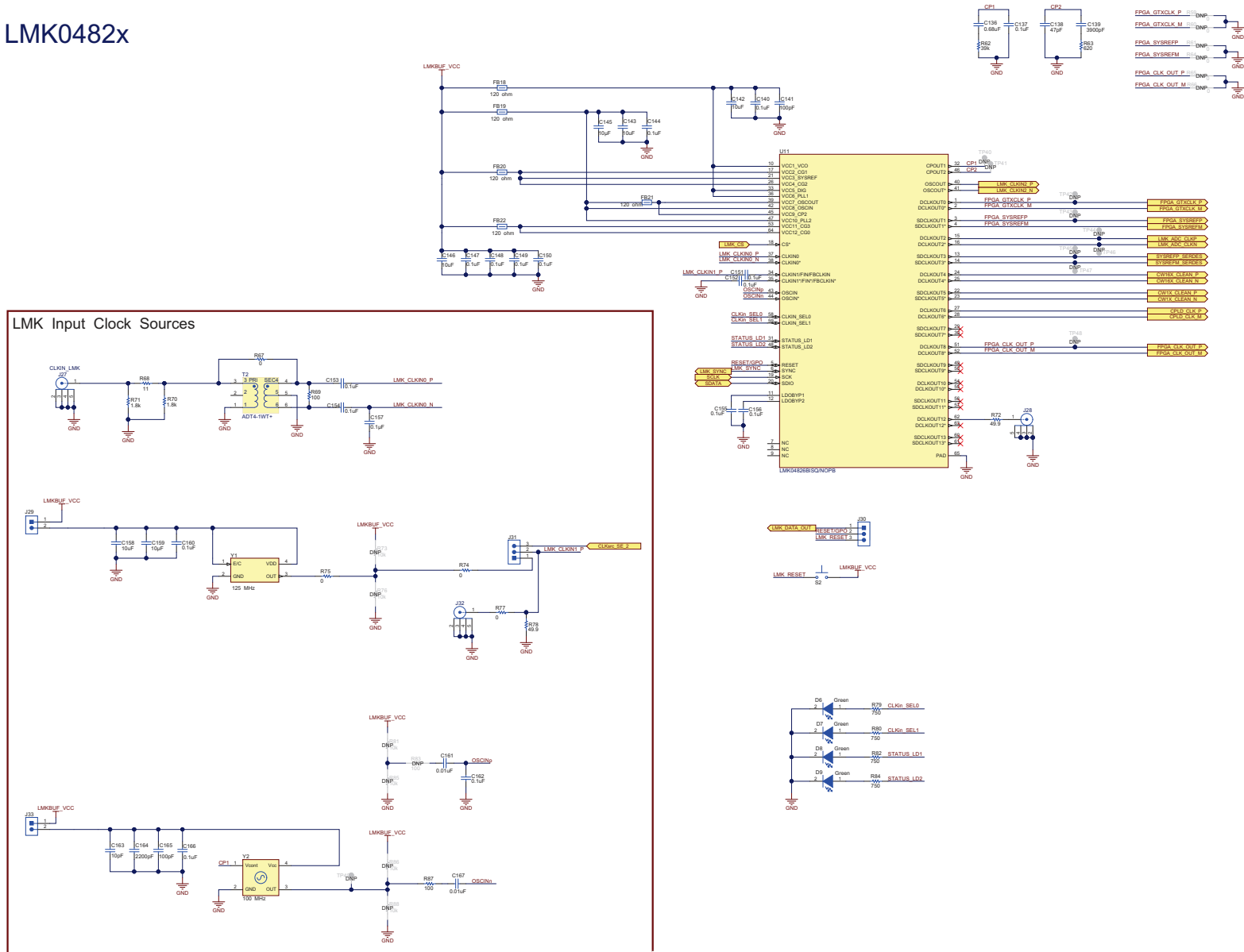

Figure 61. AFE5818 Rev C EVM Schematic 5 of 11

AFE5818 pin configuration

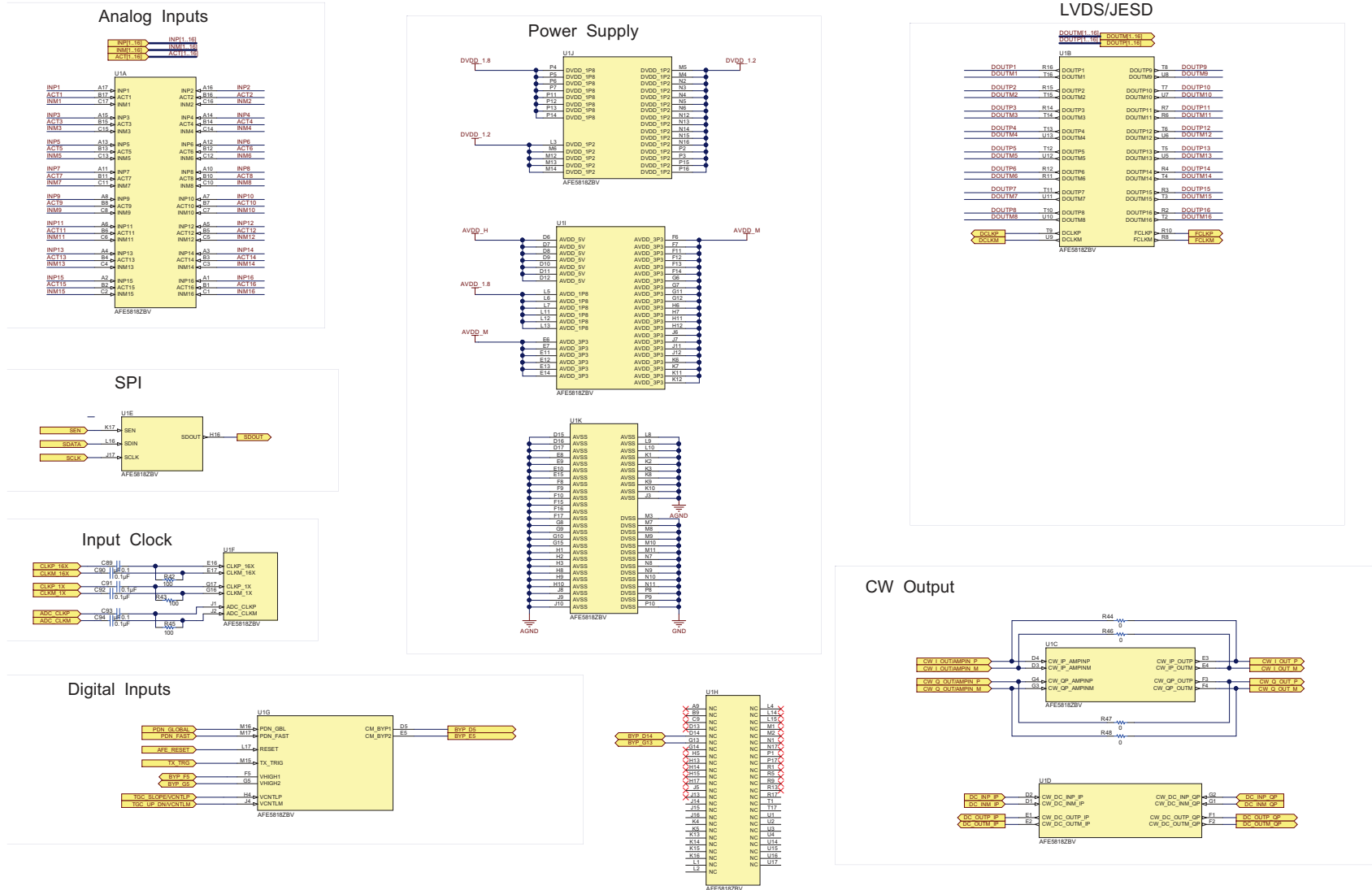

Figure 62. AFE5818 Rev C EVM Schematic 6 of 11

ADC LVDS OUTPUT

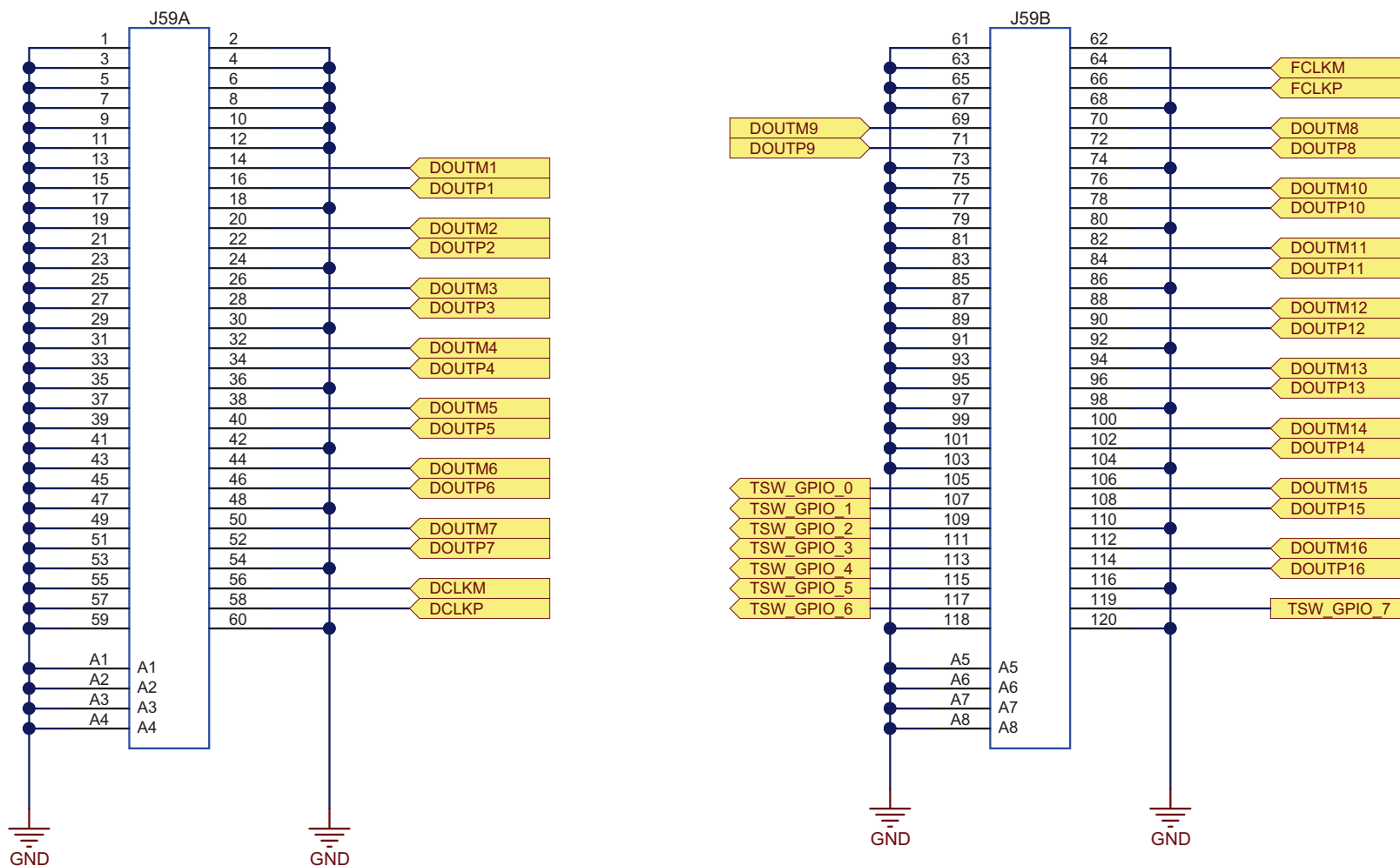

Figure 63. AFE5818 Rev C EVM Schematic 7 of 11

CW IVV OUTPUT

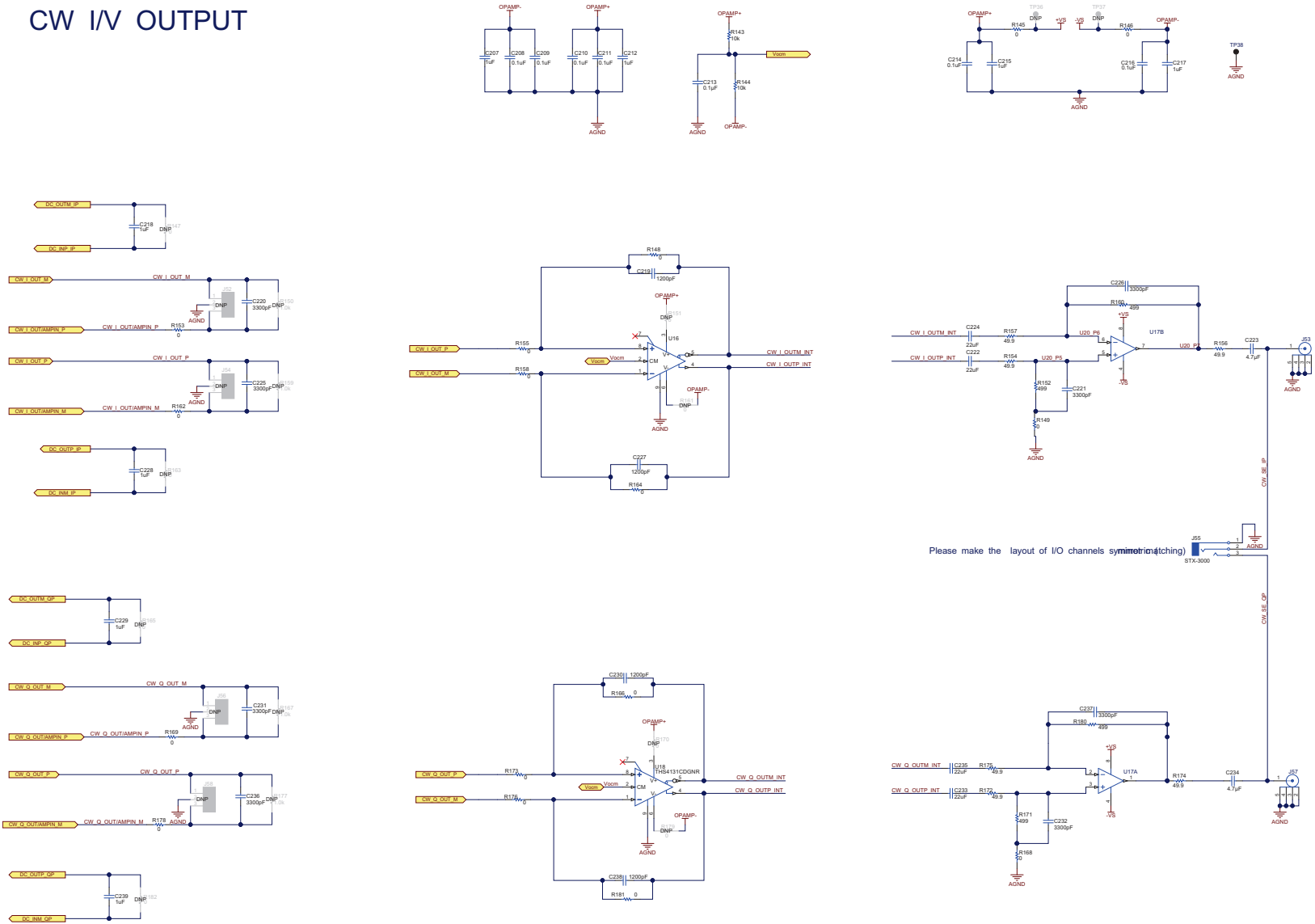
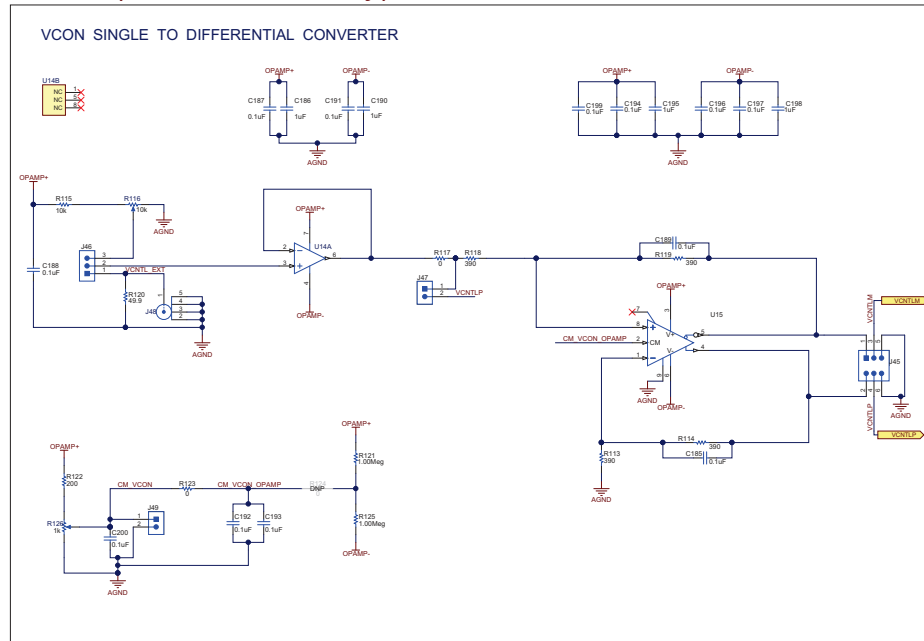
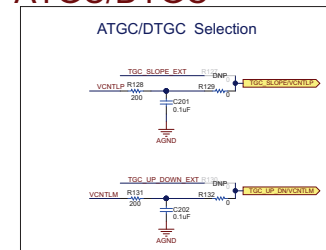

Figure 64. AFE5818 Rev C EVM Schematic 8 of 11

VCntl (AFE58xx18 Only)



ATGC/DTGC



DTGC(AFE58xx16 Only)

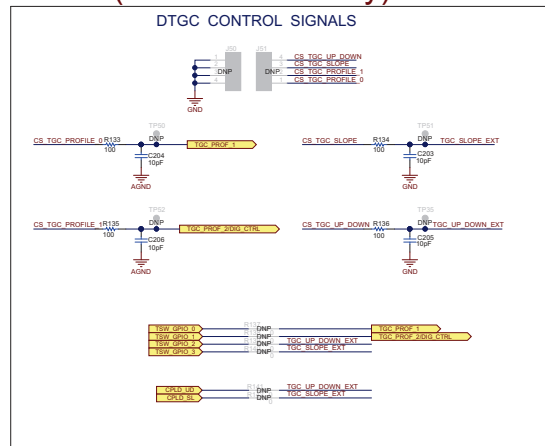

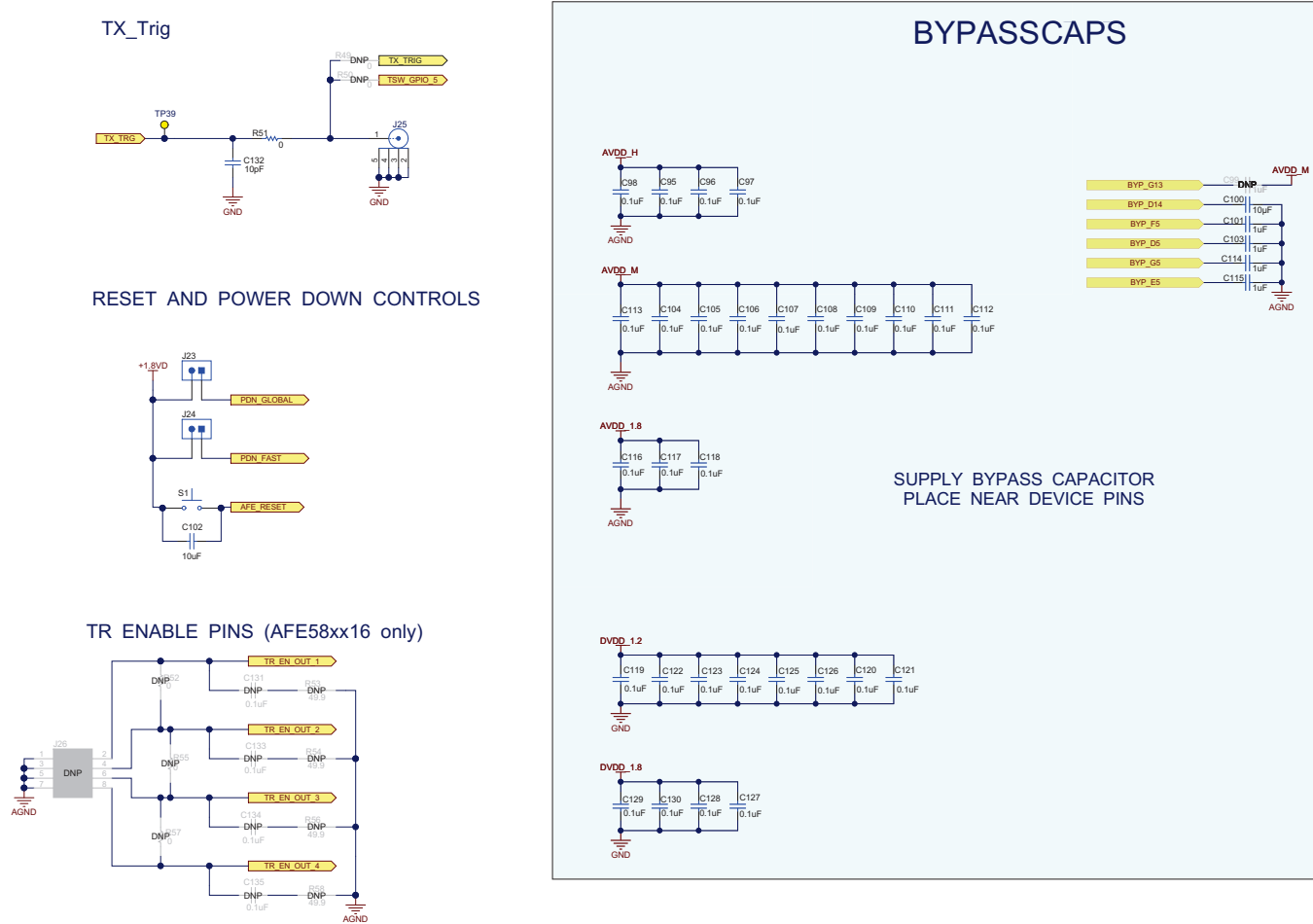

Figure 66. AFE5818 Rev C EVM Schematic 10 of 11

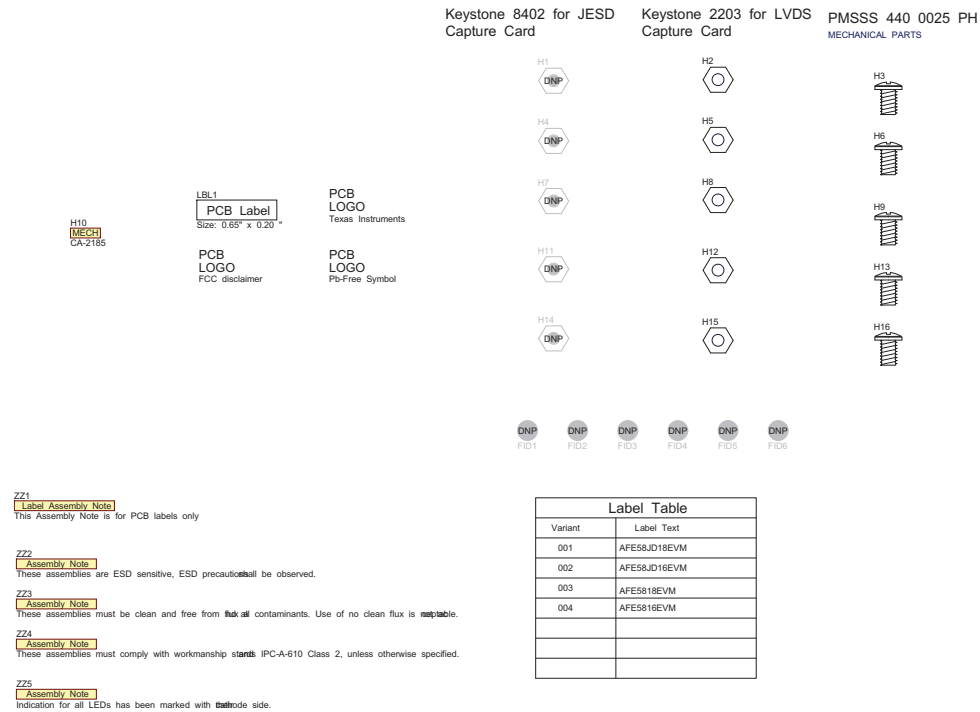

Figure 67. AFE5818 Rev C EVM Schematic 11 of 11

E.3 EVM Bill of Materials

Table 3 lists the AFE5818 EVM bill of materials (BOM).

Table 3. AFE5818 EVM Bill of Materials ⁽¹⁾

Designator	Qty	Value	Description	Package Reference	Part Number	MFR	Alternate Part Number	Alternate MFR
C1, C2, C4, C6, C9, C10, C12, C15, C18, C21, C23, C24	12	22 µF	CAP, TA, 22 µF, 16V, +/-10%, 0.375 ohm, SMD	6032-28	TPSC226K016R0375	AVX		
C3, C5, C7, C8, C11, C13, C16, C17, C20, C22	10	0.1 µF	CAP, CERM, 0.1 µF, 16V, +/-10%, X5R, 0603	0603	GRM188R61C104KA01D	Murata		
C14	1	470pF	CAP, CERM, 470pF, 50V, +/-5%, COG/NP0, 0603	0603	06035A471JAT2A	AVX		
C19, C25	2	160pF	CAP, CERM, 160 pF, 50 V, +/- 5%, COG/NP0, 0603	0603	GRM1885C1H161JA01D	Murata		
C26, C27, C28, C29, C31, C33, C34, C35, C36, C85, C86, C89, C90, C91, C92, C93, C94, C95, C96, C97, C98, C104, C105, C106, C107, C108, C109, C110, C111, C112, C113, C116, C117, C118, C119, C120, C121, C122, C123, C124, C125, C126, C127, C128, C129, C130, C137, C140, C143, C147, C148, C149, C150, C151, C152, C153, C154, C155, C156, C157, C160, C162, C166, C168, C169, C170, C171, C172, C175, C176, C177, C178, C179, C180, C181, C182, C185, C187, C188, C189, C191, C192, C193, C194, C196, C197, C199, C200, C201, C202, C208, C209, C210, C211, C213, C214, C216, C260, C261	99	0.1 µF	CAP, CERM, 0.1 µF, 16 V, +/- 10%, X7R, 0402	0402	GRM155R71C104KA88D	Murata		
C30, C32	2	47pF	CAP, CERM, 47 pF, 50 V, +/- 1%, COG/NP0, 0402	0402	GRM1555C1H470FA01D	Murata		
C37, C42, C45, C50, C53, C58, C61, C66, C69, C74, C77, C80, C81, C82, C83, C84	16	0.01 µF	CAP, CERM, 0.01 µF, 6.3 V, +/- 10%, X7R, 0402	0402	GRM155R70J103KA01D	Murata		
C38, C40, C43, C46, C48, C51, C54, C56, C59, C62, C64, C67, C70, C72, C75, C78	16	0.015 µF	CAP, CERM, 0.015 µF, 16 V, +/- 10%, X7R, 0402	0402	GRM155R71C153KA01D	Murata		
C39, C41, C44, C47, C49, C52, C55, C57, C60, C63, C65, C68, C71, C73, C76, C79, C218, C228, C229, C239	20	1 µF	CAP, CERM, 1 µF, 6.3 V, +/- 20%, X5R, 0402	0402	C1005X5R0J105M	TDK		
C100, C173	2	10 µF	CAP, CERM, 10 µF, 6.3 V, +/- 20%, X5R, 0603	0603	C0603C106M9PACTU	Kemet		

⁽¹⁾ Unless otherwise noted in the Alternate Part Number and/or Alternate Manufacturer columns, all parts may be substituted with equivalents.

Table 3. AFE5818 EVM Bill of Materials ⁽¹⁾ (continued)

Designator	Qty	Value	Description	Package Reference	Part Number	MFR	Alternate Part Number	Alternate MFR
C101, C103, C114, C115	4	1 μ F	CAP, CERM, 1 μ F, 6.3 V, +/- 20%, X5R, 0402	0402	GRM152R60J105ME15D	Murata		
C102	1	10 μ F	CAP, CERM, 10 μ F, 6.3 V, +80/-20%, Y5V, 0805_140	0805_140	GRM21BF50J106ZE01L	Murata		
C132, C163, C203, C204, C205, C206	6	10pF	CAP, CERM, 10 pF, 50 V, +/- 5%, C0G/NP0, 0402	0402	GRM1555C1H100JA01D	Murata		
C136	1	0.68 μ F	CAP, CERM, 0.68 μ F, 10 V, +/- 10%, X5R, 0603	0603	C0603C684K8PACTU	Kemet		
C138	1	47pF	CAP, CERM, 47 pF, 100 V, +/- 5%, C0G/NP0, 0603	0603	GRM1885C2A470JA01D	Murata		
C139	1	3900pF	CAP, CERM, 3900 pF, 50 V, +/- 10%, X7R, 0402	0402	GRM155R71H392KA01D	Murata		
C141, C144, C159, C165	4	100pF	CAP, CERM, 100 pF, 50 V, +/- 10%, X7R, 0402	0402	CC0402KRX7R9BB101	Yageo America		
C142, C145, C146, C158	4	10 μ F	CAP, CERM, 10 μ F, 6.3 V, +/- 20%, X5R, 0603	0603	GRM188R60J106ME47D	Murata		
C161, C167	2	0.01 μ F	CAP, CERM, 0.01 μ F, 25V, +/-10%, X7R, 0402	0402	C1005X7R1E103K	TDK		
C164	1	2200pF	CAP, CERM, 2200 pF, 50 V, +/- 10%, X7R, 0402	0402	GRM155R71H222KA01D	Murata		
C174	1	1000pF	CAP, CERM, 1000 pF, 25 V, +/- 5%, C0G/NP0, 0402	0402	C1005C0G1E102J	TDK		
C186, C190, C195, C198, C207, C212, C215, C217	8	1 μ F	CAP, CERM, 1 μ F, 16 V, +/- 10%, X5R, 0603	0603	C0603C105K4PACTU	Kemet		
C219, C227, C230, C238	4	1200pF	CAP, CERM, 1200 pF, 50 V, +/- 10%, X7R, 0603	0603	GRM188R71H122KA01D	Murata		
C220, C221, C225, C226, C231, C232, C236, C237	8	3300pF	CAP, CERM, 3300 pF, 50 V, +/- 10%, X7R, 0402	0402	GRM155R71H332KA01D	Murata		
C222, C224, C233, C235	4	22 μ F	CAP, CERM, 22 μ F, 6.3 V, +/- 20%, X5R, 0603	0603	C1608X5R0J226M080AC	TDK		
C223, C234	2	4.7 μ F	CAP, CERM, 4.7 μ F, 10 V, +/- 10%, X5R, 0603	0603	C0603C475K8PACTU	Kemet		
D1	1	Orange	LED, Orange, SMD	0.8x1.6mm	HSMC-C190	Avago		
D2, D4, D5	3	Super Red	LED, Super Red, SMD	LED, 1.6x.6x.8mm	SML-LX0603SRW-TR	Lumex		
D3	1	Red	LED, Red, SMD	0.8x1.6mm	HSMC-C190	Avago		
D6, D7, D8, D9	4	Green	LED, Green, SMD	0.8x1.6mm	HSMG-C190	Avago		
FB1, FB2, FB3, FB4, FB5, FB6, FB7, FB8, FB9, FB10, FB12, FB13, FB14, FB15, FB16, FB18, FB19, FB20, FB21, FB22, FB23	21	120 ohm	Ferrite Bead, 120 ohm @ 100 MHz, 0.8 A, 0805	0805	BLM21AG121SN1D	Murata		
FB17	1	120 ohm	Ferrite Bead, 120 ohm @ 100 MHz, 3 A, 0603	0603	BLM18SG121TN1D	Murata		
H2, H5, H8, H12, H15	5		HEX STANDOFF 4-40 ALUMINUM 1/2"	HEX STANDOFF 4-40 ALUMINUM 1/2"	2203	Keystone		
H3, H6, H9, H13, H16	5		MACHINE SCREW PAN PHILLIPS 4-40	Machine Screw, 4-40, 1/4"	PMSSS 440 0025 PH	B&F Fastener Supply		
H10	1		CABLE ASSY STR 2.1MM 6' 24 AWG		CA-2185	Tensility		

Table 3. AFE5818 EVM Bill of Materials ⁽¹⁾ (continued)

Designator	Qty	Value	Description	Package Reference	Part Number	MFR	Alternate Part Number	Alternate MFR
J1	1		Power Jack, mini, 2.1mm OD, R/A, TH	Jack, 14.5x11x9mm	RAPC722X	Switchcraft		
J2	1		Terminal Block, 3.5 mm, 3x1, Tin, TH	Terminal Block, 3.5 mm, 3x1, TH	39357-0003	Molex		
J3, J30, J31, J46	4		Header, 100mil, 3x1, Gold, TH	3x1 Header	TSW-103-07-G-S	Samtec		
J4	1		Header, 100mil, 5x1, Gold, TH	5x1 Header	TSW-105-07-G-S	Samtec		
J5	1		Connector, Receptacle, USB - mini AB, R/A, SMD	Receptacle, 5-Leads, Body 9.9x9mm, R/A	67803-8020	Molex		
J6, J9, J10, J13, J14, J17, J19, J20, J25, J27, J28, J32, J35, J39, J41, J48, J53, J57	18		SMA Straight PCB Socket Die Cast, 50 Ohm, TH	SMA Straight PCB Socket Die Cast, TH	5-1814832-1	TE Connectivity		
J7, J8, J11, J12, J15, J16, J18, J21	8		Connector, End launch SMA, 50 ohm, SMT	End Launch SMA	142-0701-801	Johnson		
J22, J59	2		Socket, 0.5MM, 60x2, Gold, SMT	Socket, Female, 0.5MM, 60x2, SMT	QTH-060-01-L-D-A	Samtec		
J23, J24, J29, J33, J37, J47, J49	7		Header, 100mil, 2x1, Gold, TH	2x1 Header	TSW-102-07-G-S	Samtec		
J34, J36, J38, J40, J45	5		Header, 100mil, 3x2, Gold, TH	3x2 Header	TSW-103-07-G-D	Samtec		
J55	1		Audio Jack, 3.5 mm, Stereo, R/A, TH	Connector, 3-Leads, 3.5mm Stereo Jack R/A, TH	STX-3000	Kycon Inc		
LBL1	1		Thermal Transfer Printable Labels, 0.650" W x 0.200" H - 10,000 per roll	PCB Label 0.650"H x 0.200"W	THT-14-423-10	Brady	-	-
R1, R7, R8, R9, R19	5	0	RES, 0, 5%, 0.1 W, 0603	0603	RC0603JR-070RL	Yageo America		
R2	1	30k	RES, 30k ohm, 5%, 0.125W, 0805	0805	CRCW080530K0JNEA	Vishay-Dale		
R3	1	604	RES, 604, 1%, 0.063 W, 0402	0402	CRCW0402604RFKED	Vishay-Dale		
R4, R13	2	5.1k	RES, 5.1k ohm, 5%, 0.1W, 0603	0603	CRCW06035K10JNEA	Vishay-Dale		
R5, R14	2	3.01k	RES, 3.01k ohm, 1%, 0.1W, 0603	0603	CRCW06033K01FKEA	Vishay-Dale		
R6, R10	2	332	RES, 332, 1%, 0.063 W, 0402	0402	CRCW0402332RFKED	Vishay-Dale		
R11, R21	2	510	RES, 510, 5%, 0.063 W, 0402	0402	CRCW0402510RJNED	Vishay-Dale		
R12	1	196	RES, 196, 1%, 0.063 W, 0402	0402	CRCW0402196RFKED	Vishay-Dale		
R22, R51, R67, R74, R75, R77, R97, R98, R117, R123, R129, R132, R145, R146, R148, R149, R153, R155, R158, R162, R164, R166, R168, R169, R173, R176, R178, R181	28	0	RES, 0, 5%, 0.063 W, 0402	0402	CRCW04020000Z0ED	Vishay-Dale		
R23, R41, R42, R43, R45, R69, R87, R89, R90, R99, R100, R101, R102	13	100	RES, 100, 1%, 0.1 W, 0402	0402	ERJ-2RKF1000X	Panasonic		
R24, R25, R26, R27, R28, R29, R30, R31, R32, R33, R34, R35, R36, R37, R38, R39, R72, R78, R91, R92, R93, R95, R120, R156, R174	25	49.9	RES, 49.9, 1%, 0.063 W, 0402	0402	CRCW040249R9FKED	Vishay-Dale		
R62	1	39k	RES, 39 k, 5%, 0.063 W, 0402	0402	CRCW040239K0JNED	Vishay-Dale		
R63	1	620	RES, 620, 5%, 0.063 W, 0402	0402	CRCW0402620RJNED	Vishay-Dale		
R68	1	11	RES, 11, 5%, 0.063 W, 0402	0402	CRCW040211R0JNED	Vishay-Dale		
R70, R71	2	1.8k	RES, 1.8 k, 5%, 0.063 W, 0402	0402	CRCW04021K80JNED	Vishay-Dale		

Table 3. AFE5818 EVM Bill of Materials ⁽¹⁾ (continued)

Designator	Qty	Value	Description	Package Reference	Part Number	MFR	Alternate Part Number	Alternate MFR
R79, R80, R82, R84	4	750	RES, 750, 5%, 0.063 W, 0402	0402	CRCW0402750RJNED	Vishay-Dale		
R94	1	60.4k	RES, 60.4k ohm, 1%, 0.063W, 0402	0402	CRCW040260K4FKED	Vishay-Dale		
R113, R114, R118, R119	4	390	RES, 390, 0.1%, 0.1 W, 0603	0603	RG1608P-391-B-T5	Susumu Co Ltd		
R115, R143, R144	3	10k	RES, 10 k, 5%, 0.063 W, 0402	0402	CRCW040210K0JNED	Vishay-Dale		
R116	1	10k	Trimmer, 10k ohm, 0.5W, TH	9.5x10x4.8mm	3296W-1-103LF	Bourns		
R121, R125	2	1.00Meg	RES, 1.00 M, 1%, 0.1 W, 0603	0603	CRCW06031M00FKEA	Vishay-Dale		
R122	1	200	RES, 200 ohm, 0.1%, 0.125W, 0805	0805	RG2012P-201-B-T5	Susumu Co Ltd		
R126	1	1k	Trimmer, 1k ohm, 0.5W, TH	9.5x10x4.8mm	3296W-1-102LF	Bourns		
R128, R131	2	200	RES, 200, 1%, 0.1 W, 0603	0603	CRCW0603200RFKEA	Vishay-Dale		
R133, R134, R135, R136	4	100	RES, 100, 1%, 0.1 W, 0603	0603	CRCW0603100RFKEA	Vishay-Dale		
R152, R160, R171, R180	4	499	RES, 499, 1%, 0.1 W, 0603	0603	CRCW0603499RFKEA	Vishay-Dale		
R154, R157, R172, R175	4	49.9	RES, 49.9, 0.1%, 0.1 W, 0603	0603	RT0603BRD0749R9L	Yageo America		
S1, S2	2		Switch, Tactile, SPST-NO, 0.05A, 12V, SMT	Switch, 4.4x2x2.9 mm	TL1015AF160QG	E-Switch		
SH-5, SH-6, SH-7, SH-8	4	1x2	Shunt, 100mil, Gold plated, Black	Shunt	SNT-100-BK-G	Samtec	969102-0000-DA	3M
T2, T3, T4, T5	4		RF Transformer, 50 ohm, 2 to 775 MHz, SMT	CD542	ADT4-1WT+	Minicircuits		
TP1, TP4, TP5, TP6, TP8, TP9, TP15	7	Red	Test Point, Miniature, Red, TH	Red Miniature Testpoint	5000	Keystone		
TP2, TP11, TP12, TP13, TP14, TP16, TP17, TP18, TP38	9	Black	Test Point, Miniature, Black, TH	Black Miniature Testpoint	5001	Keystone		
TP3	1	White	Test Point, Miniature, White, TH	White Miniature Testpoint	5002	Keystone		
TP39	1	Yellow	Test Point, Miniature, Yellow, TH	Yellow Miniature Testpoint	5004	Keystone		
U1	1		16-Channel, Ultrasound, Analog Front-End with 140-mW/Channel Power, 0.75-nV/vHz Noise, 14-Bit, 65-MSPS or 12-Bit, 80-MSPS ADC, and Passive CW Mixer, ZBV0289A	ZBV0289A	AFE5818ZBV	Texas Instruments		Texas Instruments
U2	1		Single Output High PSRR LDO, 1 A, Fixed 3.3 V Output, 2.7 to 5.5 V Input, 6-pin SOT-223 (DCQ), -40 to 125 degC, Green (RoHS & no Sb/Br)	DCQ0006A	TPS79633DCQR	Texas Instruments	Equivalent	None
U3, U4, U5	3		Ultralow-Noise, High PSRR, Fast, RF, 1A, Low-Dropout Linear Regulator, DCQ0006A	DCQ0006A	TPS79601DCQR	Texas Instruments		Texas Instruments
U6	1		4242-VPK Small-Footprint and Low-Power Quad Channels Digital Isolators, DBQ0016A	DBQ0016A	ISO7140CCDBQR	Texas Instruments	ISO7140CCDBQ	Texas Instruments
U7	1		USB FIFO IC, 28SSOP	SSOP28	FT245RL	FTDI		
U8	1		4-Bit Dual-supply Bus Transceiver with Configurable Voltage Translation and 3-State Outputs, PW0016A	PW0016A	SN74AVC4T245PWR	Texas Instruments		Texas Instruments
U9	1		4242-VPK Small-Footprint and Low-Power Quad Channels Digital Isolators, DBQ0016A	DBQ0016A	ISO7141CCDBQR	Texas Instruments	ISO7141CCDBQ	Texas Instruments

Table 3. AFE5818 EVM Bill of Materials ⁽¹⁾ (continued)

Designator	Qty	Value	Description	Package Reference	Part Number	MFR	Alternate Part Number	Alternate MFR
U10	1		Ultralow-Noise, High PSRR, Fast, RF, 1A Low-Dropout Linear Regulator, DCQ0006A	DCQ0006A	TPS79618DCQR	Texas Instruments		Texas Instruments
U11	1		Ultra Low-Noise JESD204B Compliant Clock Jitter Cleaner with Dual Loop PLLs, NKD0064A	NKD0064A	LMK04826BISQ/NOPB	Texas Instruments		Texas Instruments
U12	1		CLOCK BUFFER WITH PROGRAMMABLE DIVIDER, LVPECL I/O + ADDITIONAL LVCMOS OUTPUT, RGT0016A	RGT0016A	CDCM1802RGTR	Texas Instruments	CDCM1802RGTT	Texas Instruments
U14	1		1.1 nV/rtHz Noise, Low Power, Precision Operational Amplifier, 4.5 to 36 V, -40 to 125 degC, 8-pin SOIC (D0008A), Green (RoHS & no Sb/Br)	D0008A	OPA211AIDR	Texas Instruments	Equivalent	None
U15, U16, U18	3		HIGH-SPEED, LOW-NOISE, FULLY-DIFFERENTIAL I/O AMPLIFIERS, DGN0008D	DGN0008D	THS4131CDGNR	Texas Instruments	THS4131CDGN	Texas Instruments
U17	1		Dual, High Gain Bandwidth, High Output Current, Operational Amplifier with Current Limit, 5 to 12 V, -40 to 85 degC, 8-pin SOIC (D8), Green (RoHS & no Sb/Br)	D0008A	OPA2614ID	Texas Instruments	Equivalent	Texas Instruments
U20	1		SINGLE-BIT DUAL-SUPPLY BUS TRANSCEIVER WITH CONFIGURABLE VOLTAGE TRANSLATION AND 3-STATE OUTPUTS, DBV0006A	DBV0006A	SN74AVCH145DBVR	Texas Instruments	SN74AVCH145DBVT	Texas Instruments
Y1	1		OSC, 3.3 V, 125 MHz, 15 pF, SMD	7x5mm	VCC1-B3B-125M000000	Vectron		
Y2	1		VCXO, 100 MHz, 3.3V, SMD	CVHD-950-4	CVHD-950-100.000	Crystek Corporation		
Y3	1		OSC, 3.3 V, 40 MHz, SMD	SMD, 4-Leads, Body 7x5mm	FXO-HC735-40	Fox Electronics		
C87, C88, C131, C133, C134, C135, C240, C241, C242, C243, C244, C245, C246, C247, C248, C249, C250, C251, C252, C253, C254, C255, C256, C257, C258, C259	0	0.1 µF	CAP, CERM, 0.1 µF, 16 V, +/- 10%, X7R, 0402	0402	GRM155R71C104KA88D	Murata		
C99	0	1 µF	CAP, CERM, 1 µF, 6.3 V, +/- 20%, X5R, 0402	0402	GRM152R60J105ME15D	Murata		
C183, C184	0	0.1 µF	CAP, CERM, 0.1 µF, 16V, +/-10%, X5R, 0603	0603	GRM188R61C104KA01D	Murata		
D10, D11, D12	0	Super Red	LED, Super Red, SMD	LED, 1.6x.6x.8mm	SML-LX0603SRW-TR	Lumex		
FB11, FB24, FB25	0	120 ohm	Ferrite Bead, 120 ohm @ 100 MHz, 0.8 A, 0805	0805	BLM21AG121SN1D	Murata		
H1, H4, H7, H11, H14	0		HEX, M-F STANDOFF 4-40 ALUMINUM 5/8"	HEX, M-F STANDOFF 4-40 ALUMINUM 5/8"	8402	Keystone		
J26, J44	0		Header, 100mil, 4x2, Gold, TH	4x2 Header	TSW-104-07-G-D	Samtec		
J42	0		Header, 100mil, 6x1, Gold, TH	6x1 Header	TSW-106-07-G-S	Samtec		
J43	0		SMA Straight PCB Socket Die Cast, 50 Ohm, TH	SMA Straight PCB Socket Die Cast, TH	5-1814832-1	TE Connectivity		
J50, J51	0		Header, 100mil, 4x1, Gold, TH	4x1 Header	TSW-104-07-G-S	Samtec		

Table 3. AFE5818 EVM Bill of Materials ⁽¹⁾ (continued)

Designator	Qty	Value	Description	Package Reference	Part Number	MFR	Alternate Part Number	Alternate MFR
J52, J54, J56, J58	0		Header, 100mil, 3x1, Gold, TH	3x1 Header	TSW-103-07-G-S	Samtec		
J60	0		Connector, Male, 1.27 mm, 40x4, SMD	Connector, Male, 1.27 mm, 40x4, SMD	ASP-134602-01	Samtec		
R15, R16, R17, R18, R20, R40, R44, R46, R47, R48, R49, R50, R52, R55, R57, R59, R60, R61, R64, R65, R66, R103, R107, R124, R127, R130, R137, R138, R139, R141, R142, R147, R151, R161, R163, R165, R170, R179, R182, R183	0	0	RES, 0, 5%, 0.063 W, 0402	0402	CRCW04020000Z0ED	Vishay-Dale		
R53, R54, R56, R58	0	49.9	RES, 49.9, 1%, 0.063 W, 0402	0402	CRCW040249R9FKED	Vishay-Dale		
R73, R76, R81, R85, R86, R88	0	10k	RES, 10 k, 5%, 0.063 W, 0402	0402	CRCW040210K0JNED	Vishay-Dale		
R83, R104, R105, R106	0	100	RES, 100, 1%, 0.1 W, 0402	0402	ERJ-2RKF1000X	Panasonic		
R96, R140	0		RES, 0, 5%, 0.063 W, 0402	0402	CRCW04020000Z0ED	Vishay-Dale		
R108, R109, R110, R111, R112	0	10.0k	RES, 10.0 k, 1%, 0.1 W, 0603	0603	ERJ-3EKF1002V	Panasonic		
R150, R159, R167, R177	0	1.0k	RES, 1.0 k, 5%, 0.1 W, 0603	0603	CRCW06031K00JNEA	Vishay-Dale		
S3	0		Switch, Tactile, SPST-NO, 0.05A, 12V, SMT	Switch, 4.4x2x2.9 mm	TL1015AF160QG	E-Switch		
S4	0		Switch, SPST, 4 Pos, Top Actuated, SMD	SMD, 8-Leads, Pitch 1.27mm	1571983-5	TE Connectivity		
SH-1, SH-2, SH-3, SH-4	0	1x2	Shunt, 100mil, Gold plated, Black	Shunt	SNT-100-BK-G	Samtec	969102-0000-DA	3M
T1	0		RF Transformer, 50 ohm, 2 to 775 MHz, SMT	CD542	ADT4-1WT+	Minicircuits		
TP7, TP37	0	White	Test Point, Miniature, White, TH	White Miniature Testpoint	5002	Keystone		
TP10, TP36	0	Red	Test Point, Miniature, Red, TH	Red Miniature Testpoint	5000	Keystone		
TP19, TP20, TP21, TP22, TP23, TP24, TP25, TP26, TP27, TP28, TP29, TP30, TP31, TP32, TP33, TP34, TP35, TP50, TP51, TP52	0	Orange	Test Point, Miniature, Orange, TH	Orange Miniature Testpoint	5003	Keystone		
TP40, TP41, TP42, TP43, TP44, TP45, TP46, TP47, TP48, TP49	0	Blue	Test Point, Miniature, Blue, TH	Blue Miniature Testpoint	5117	Keystone		
U13	0		CoolRunner-II CPLD, QFG32	5x5 QFN32	XC2C32A-6QFG32C	Xilinx		
U19	0		64K I2C Smart Serial EEPROM, SOIC-8	SOIC-8, 208mil wide	24LC65-I/SM	Microchip		

FAQ and Troubleshooting

F.1 Common Issues

The following section illustrates some of the common problems seen when attempting to use the EVM hardware and software.

F.1.1 Issues

- **Windows 8 and Windows 10 support:** Officially, the EVM software is only supported for Windows 7. Windows 8 and 10, however, are often known to work but might require enabling .NET FRAMEWORK 3.5. In *Control Panel*, choose *Programs and Features*, choose *Turn Windows features on or off*, and then select the .NET Framework 3.5 (includes .NET 2.0 and 3.0) check box. This option requires an internet connection. Do not select the child items.

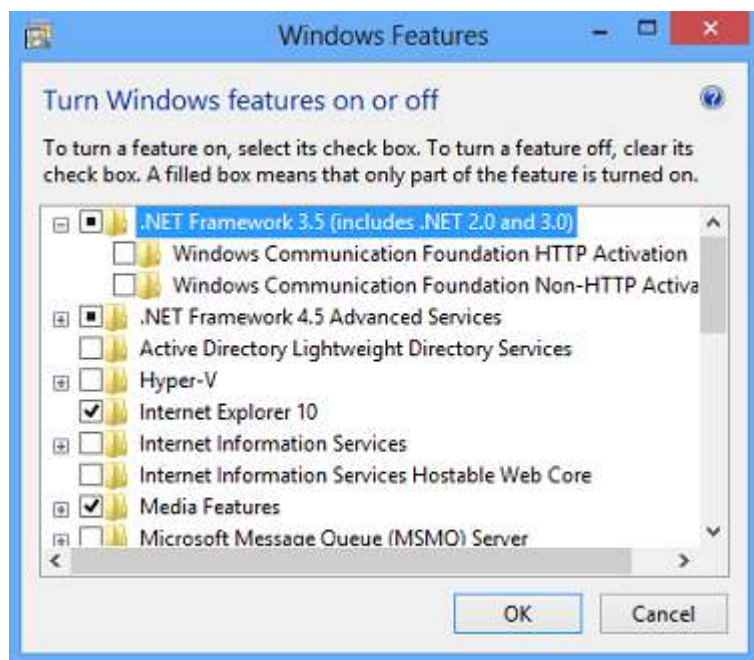

Figure 68. Enable .NET Framework

- **Power supply capacity:** It is likely that both the AFE EVM and the TSW EVM do not have a wall power supply. Instead, they include the ability to connect to a bench-top supply via the provided cable. It is critical that each of these EVMs has access to 2 A of current capacity.
- **No Capture in HSDCPro:** It is possible that once the GUIs and EVMs are configured for capture, and the capture button in HSDCPro is pressed, that nothing seems to happen and eventually the GUI will timeout and a pop-up an error appears as seen in [Figure 69](#). Reasons for this can include the following:
 - Incorrect firmware loaded
 - Current starvation on at least one EVM, 2 A is sufficient
 - Missing Data output clock from the AFE to the FGPA. With LVDS, this could be the FCLK or DCLK. D5 of the TSW1400 should turn on, and if not, this is probably the reason. With JESD204B data, a

missing GTX Clk or SysRef clock to the FPGA could be the reason.

- Verify that the EVMs are mechanically mated correctly
- Verify power supply to both EVMs
- Verify jumper settings on the AFE EVM. Particularly inspect J29, J33, J37, J31, J34, and J36.
- Use an oscilloscope to test the frequency of the clock at header J36 or J34. This should be a 50-MHz square wave. TP44 should be 200 MHz. If using JESD, also check TP42 near the LMK04826, this should be either 200 MHz or 400 MHz, by default. Also check TP43.

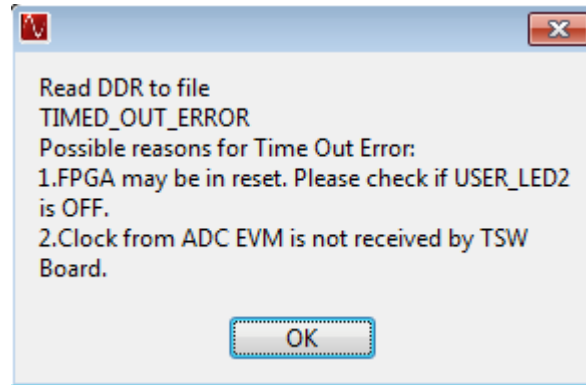

Figure 69. Read DDR Error for No Capture

Revision History

Changes from Original (October 2015) to A Revision	Page
• Modified the abstract.....	1
• Changed board image and text and renamed the <i>EVM Hardware Overview</i> section.....	4
• Moved and changed text in the <i>GUI Software Installation</i> section.....	5
• Moved and changed the section name of the <i>Quick Views of Evaluation Setups for LVDS Interface</i> section.	6
• Changed text in the <i>Quick Views of Evaluation Setups for LVDS Interface</i> section.....	6
• Changed text and section name in the <i>Testing the EVM Data Capture with LVDS</i> section.....	8
• Completely overhauled the <i>Software Installation</i> section.....	18
• Added the <i>Hardware Configuration</i> section.	31
• Added the <i>Triggering Options</i> section.....	35
• Added the <i>Common Hardware Modifications</i> section.	37
• Added the <i>AFE5818 EVM Hardware Overview</i> and <i>Schematics</i> sections to Appendix E.	38
• Updated the <i>Bill of Materials</i> in Appendix E.	38
• Added the <i>FAQ and Troubleshooting</i> section.	57

NOTE: Page numbers for previous revisions may differ from page numbers in the current version.

STANDARD TERMS AND CONDITIONS FOR EVALUATION MODULES

1. *Delivery:* TI delivers TI evaluation boards, kits, or modules, including any accompanying demonstration software, components, or documentation (collectively, an "EVM" or "EVMs") to the User ("User") in accordance with the terms and conditions set forth herein. Acceptance of the EVM is expressly subject to the following terms and conditions.
 - 1.1 EVMs are intended solely for product or software developers for use in a research and development setting to facilitate feasibility evaluation, experimentation, or scientific analysis of TI semiconductors products. EVMs have no direct function and are not finished products. EVMs shall not be directly or indirectly assembled as a part or subassembly in any finished product. For clarification, any software or software tools provided with the EVM ("Software") shall not be subject to the terms and conditions set forth herein but rather shall be subject to the applicable terms and conditions that accompany such Software
 - 1.2 EVMs are not intended for consumer or household use. EVMs may not be sold, sublicensed, leased, rented, loaned, assigned, or otherwise distributed for commercial purposes by Users, in whole or in part, or used in any finished product or production system.
2. *Limited Warranty and Related Remedies/Disclaimers:*
 - 2.1 These terms and conditions do not apply to Software. The warranty, if any, for Software is covered in the applicable Software License Agreement.
 - 2.2 TI warrants that the TI EVM will conform to TI's published specifications for ninety (90) days after the date TI delivers such EVM to User. Notwithstanding the foregoing, TI shall not be liable for any defects that are caused by neglect, misuse or mistreatment by an entity other than TI, including improper installation or testing, or for any EVMs that have been altered or modified in any way by an entity other than TI. Moreover, TI shall not be liable for any defects that result from User's design, specifications or instructions for such EVMs. Testing and other quality control techniques are used to the extent TI deems necessary or as mandated by government requirements. TI does not test all parameters of each EVM.
 - 2.3 If any EVM fails to conform to the warranty set forth above, TI's sole liability shall be at its option to repair or replace such EVM, or credit User's account for such EVM. TI's liability under this warranty shall be limited to EVMs that are returned during the warranty period to the address designated by TI and that are determined by TI not to conform to such warranty. If TI elects to repair or replace such EVM, TI shall have a reasonable time to repair such EVM or provide replacements. Repaired EVMs shall be warranted for the remainder of the original warranty period. Replaced EVMs shall be warranted for a new full ninety (90) day warranty period.
3. *Regulatory Notices:*
 - 3.1 *United States*
 - 3.1.1 *Notice applicable to EVMs not FCC-Approved:*

This kit is designed to allow product developers to evaluate electronic components, circuitry, or software associated with the kit to determine whether to incorporate such items in a finished product and software developers to write software applications for use with the end product. This kit is not a finished product and when assembled may not be resold or otherwise marketed unless all required FCC equipment authorizations are first obtained. Operation is subject to the condition that this product not cause harmful interference to licensed radio stations and that this product accept harmful interference. Unless the assembled kit is designed to operate under part 15, part 18 or part 95 of this chapter, the operator of the kit must operate under the authority of an FCC license holder or must secure an experimental authorization under part 5 of this chapter.
 - 3.1.2 *For EVMs annotated as FCC – FEDERAL COMMUNICATIONS COMMISSION Part 15 Compliant:*

CAUTION

This device complies with part 15 of the FCC Rules. Operation is subject to the following two conditions: (1) This device may not cause harmful interference, and (2) this device must accept any interference received, including interference that may cause undesired operation.

Changes or modifications not expressly approved by the party responsible for compliance could void the user's authority to operate the equipment.

FCC Interference Statement for Class A EVM devices

NOTE: This equipment has been tested and found to comply with the limits for a Class A digital device, pursuant to part 15 of the FCC Rules. These limits are designed to provide reasonable protection against harmful interference when the equipment is operated in a commercial environment. This equipment generates, uses, and can radiate radio frequency energy and, if not installed and used in accordance with the instruction manual, may cause harmful interference to radio communications. Operation of this equipment in a residential area is likely to cause harmful interference in which case the user will be required to correct the interference at his own expense.

FCC Interference Statement for Class B EVM devices

NOTE: This equipment has been tested and found to comply with the limits for a Class B digital device, pursuant to part 15 of the FCC Rules. These limits are designed to provide reasonable protection against harmful interference in a residential installation. This equipment generates, uses and can radiate radio frequency energy and, if not installed and used in accordance with the instructions, may cause harmful interference to radio communications. However, there is no guarantee that interference will not occur in a particular installation. If this equipment does cause harmful interference to radio or television reception, which can be determined by turning the equipment off and on, the user is encouraged to try to correct the interference by one or more of the following measures:

- Reorient or relocate the receiving antenna.
- Increase the separation between the equipment and receiver.
- Connect the equipment into an outlet on a circuit different from that to which the receiver is connected.
- Consult the dealer or an experienced radio/TV technician for help.

3.2 Canada

3.2.1 For EVMs issued with an Industry Canada Certificate of Conformance to RSS-210

Concerning EVMs Including Radio Transmitters:

This device complies with Industry Canada license-exempt RSS standard(s). Operation is subject to the following two conditions: (1) this device may not cause interference, and (2) this device must accept any interference, including interference that may cause undesired operation of the device.

Concernant les EVMs avec appareils radio:

Le présent appareil est conforme aux CNR d'Industrie Canada applicables aux appareils radio exempts de licence. L'exploitation est autorisée aux deux conditions suivantes: (1) l'appareil ne doit pas produire de brouillage, et (2) l'utilisateur de l'appareil doit accepter tout brouillage radioélectrique subi, même si le brouillage est susceptible d'en compromettre le fonctionnement.

Concerning EVMs Including Detachable Antennas:

Under Industry Canada regulations, this radio transmitter may only operate using an antenna of a type and maximum (or lesser) gain approved for the transmitter by Industry Canada. To reduce potential radio interference to other users, the antenna type and its gain should be so chosen that the equivalent isotropically radiated power (e.i.r.p.) is not more than that necessary for successful communication. This radio transmitter has been approved by Industry Canada to operate with the antenna types listed in the user guide with the maximum permissible gain and required antenna impedance for each antenna type indicated. Antenna types not included in this list, having a gain greater than the maximum gain indicated for that type, are strictly prohibited for use with this device.

Concernant les EVMs avec antennes détachables

Conformément à la réglementation d'Industrie Canada, le présent émetteur radio peut fonctionner avec une antenne d'un type et d'un gain maximal (ou inférieur) approuvé pour l'émetteur par Industrie Canada. Dans le but de réduire les risques de brouillage radioélectrique à l'intention des autres utilisateurs, il faut choisir le type d'antenne et son gain de sorte que la puissance isotrope rayonnée équivalente (p.i.r.e.) ne dépasse pas l'intensité nécessaire à l'établissement d'une communication satisfaisante. Le présent émetteur radio a été approuvé par Industrie Canada pour fonctionner avec les types d'antenne énumérés dans le manuel d'usage et ayant un gain admissible maximal et l'impédance requise pour chaque type d'antenne. Les types d'antenne non inclus dans cette liste, ou dont le gain est supérieur au gain maximal indiqué, sont strictement interdits pour l'exploitation de l'émetteur.

3.3 Japan

3.3.1 *Notice for EVMs delivered in Japan:* Please see http://www.tij.co.jp/lstds/ti_ja/general/eStore/notice_01.page 日本国内に輸入される評価用キット、ボードについては、次のところをご覧ください。
http://www.tij.co.jp/lstds/ti_ja/general/eStore/notice_01.page

3.3.2 *Notice for Users of EVMs Considered "Radio Frequency Products" in Japan:* EVMs entering Japan may not be certified by TI as conforming to Technical Regulations of Radio Law of Japan.

If User uses EVMs in Japan, not certified to Technical Regulations of Radio Law of Japan, User is required by Radio Law of Japan to follow the instructions below with respect to EVMs:

1. Use EVMs in a shielded room or any other test facility as defined in the notification #173 issued by Ministry of Internal Affairs and Communications on March 28, 2006, based on Sub-section 1.1 of Article 6 of the Ministry's Rule for Enforcement of Radio Law of Japan,
2. Use EVMs only after User obtains the license of Test Radio Station as provided in Radio Law of Japan with respect to EVMs, or
3. Use of EVMs only after User obtains the Technical Regulations Conformity Certification as provided in Radio Law of Japan with respect to EVMs. Also, do not transfer EVMs, unless User gives the same notice above to the transferee. Please note that if User does not follow the instructions above, User will be subject to penalties of Radio Law of Japan.

【無線電波を送信する製品の開発キットをお使いになる際の注意事項】 開発キットの中には技術基準適合証明を受けていないものがあります。技術適合証明を受けていないものご使用に際しては、電波法遵守のため、以下のいずれかの措置を取っていただく必要がありますのでご注意ください。

1. 電波法施行規則第6条第1項第1号に基づく平成18年3月28日総務省告示第173号で定められた電波暗室等の試験設備でご使用いただく。
2. 実験局の免許を取得後ご使用いただく。
3. 技術基準適合証明を取得後ご使用いただく。

なお、本製品は、上記の「ご使用にあたっての注意」を譲渡先、移転先に通知しない限り、譲渡、移転できないものとします。

上記を遵守頂けない場合は、電波法の罰則が適用される可能性があることをご留意ください。日本テキサス・インスツルメンツ株式会社
東京都新宿区西新宿 6 丁目 2 4 番 1 号
西新宿三井ビル

3.3.3 *Notice for EVMs for Power Line Communication:* Please see http://www.tij.co.jp/llds/ti_ja/general/eStore/notice_02.page
電力線搬送波通信についての開発キットをお使いになる際の注意事項については、次のところをご覧ください。http://www.tij.co.jp/llds/ti_ja/general/eStore/notice_02.page

4 *EVM Use Restrictions and Warnings:*

4.1 EVMS ARE NOT FOR USE IN FUNCTIONAL SAFETY AND/OR SAFETY CRITICAL EVALUATIONS, INCLUDING BUT NOT LIMITED TO EVALUATIONS OF LIFE SUPPORT APPLICATIONS.

4.2 User must read and apply the user guide and other available documentation provided by TI regarding the EVM prior to handling or using the EVM, including without limitation any warning or restriction notices. The notices contain important safety information related to, for example, temperatures and voltages.

4.3 *Safety-Related Warnings and Restrictions:*

4.3.1 User shall operate the EVM within TI's recommended specifications and environmental considerations stated in the user guide, other available documentation provided by TI, and any other applicable requirements and employ reasonable and customary safeguards. Exceeding the specified performance ratings and specifications (including but not limited to input and output voltage, current, power, and environmental ranges) for the EVM may cause personal injury or death, or property damage. If there are questions concerning performance ratings and specifications, User should contact a TI field representative prior to connecting interface electronics including input power and intended loads. Any loads applied outside of the specified output range may also result in unintended and/or inaccurate operation and/or possible permanent damage to the EVM and/or interface electronics. Please consult the EVM user guide prior to connecting any load to the EVM output. If there is uncertainty as to the load specification, please contact a TI field representative. During normal operation, even with the inputs and outputs kept within the specified allowable ranges, some circuit components may have elevated case temperatures. These components include but are not limited to linear regulators, switching transistors, pass transistors, current sense resistors, and heat sinks, which can be identified using the information in the associated documentation. When working with the EVM, please be aware that the EVM may become very warm.

4.3.2 EVMs are intended solely for use by technically qualified, professional electronics experts who are familiar with the dangers and application risks associated with handling electrical mechanical components, systems, and subsystems. User assumes all responsibility and liability for proper and safe handling and use of the EVM by User or its employees, affiliates, contractors or designees. User assumes all responsibility and liability to ensure that any interfaces (electronic and/or mechanical) between the EVM and any human body are designed with suitable isolation and means to safely limit accessible leakage currents to minimize the risk of electrical shock hazard. User assumes all responsibility and liability for any improper or unsafe handling or use of the EVM by User or its employees, affiliates, contractors or designees.

4.4 User assumes all responsibility and liability to determine whether the EVM is subject to any applicable international, federal, state, or local laws and regulations related to User's handling and use of the EVM and, if applicable, User assumes all responsibility and liability for compliance in all respects with such laws and regulations. User assumes all responsibility and liability for proper disposal and recycling of the EVM consistent with all applicable international, federal, state, and local requirements.

5. *Accuracy of Information:* To the extent TI provides information on the availability and function of EVMs, TI attempts to be as accurate as possible. However, TI does not warrant the accuracy of EVM descriptions, EVM availability or other information on its websites as accurate, complete, reliable, current, or error-free.

6. *Disclaimers:*
- 6.1 EXCEPT AS SET FORTH ABOVE, EVMS AND ANY WRITTEN DESIGN MATERIALS PROVIDED WITH THE EVM (AND THE DESIGN OF THE EVM ITSELF) ARE PROVIDED "AS IS" AND "WITH ALL FAULTS." TI DISCLAIMS ALL OTHER WARRANTIES, EXPRESS OR IMPLIED, REGARDING SUCH ITEMS, INCLUDING BUT NOT LIMITED TO ANY IMPLIED WARRANTIES OF MERCHANTABILITY OR FITNESS FOR A PARTICULAR PURPOSE OR NON-INFRINGEMENT OF ANY THIRD PARTY PATENTS, COPYRIGHTS, TRADE SECRETS OR OTHER INTELLECTUAL PROPERTY RIGHTS.
- 6.2 EXCEPT FOR THE LIMITED RIGHT TO USE THE EVM SET FORTH HEREIN, NOTHING IN THESE TERMS AND CONDITIONS SHALL BE CONSTRUED AS GRANTING OR CONFERRING ANY RIGHTS BY LICENSE, PATENT, OR ANY OTHER INDUSTRIAL OR INTELLECTUAL PROPERTY RIGHT OF TI, ITS SUPPLIERS/LICENSORS OR ANY OTHER THIRD PARTY, TO USE THE EVM IN ANY FINISHED END-USER OR READY-TO-USE FINAL PRODUCT, OR FOR ANY INVENTION, DISCOVERY OR IMPROVEMENT MADE, CONCEIVED OR ACQUIRED PRIOR TO OR AFTER DELIVERY OF THE EVM.
7. *USER'S INDEMNITY OBLIGATIONS AND REPRESENTATIONS.* USER WILL DEFEND, INDEMNIFY AND HOLD TI, ITS LICENSORS AND THEIR REPRESENTATIVES HARMLESS FROM AND AGAINST ANY AND ALL CLAIMS, DAMAGES, LOSSES, EXPENSES, COSTS AND LIABILITIES (COLLECTIVELY, "CLAIMS") ARISING OUT OF OR IN CONNECTION WITH ANY HANDLING OR USE OF THE EVM THAT IS NOT IN ACCORDANCE WITH THESE TERMS AND CONDITIONS. THIS OBLIGATION SHALL APPLY WHETHER CLAIMS ARISE UNDER STATUTE, REGULATION, OR THE LAW OF TORT, CONTRACT OR ANY OTHER LEGAL THEORY, AND EVEN IF THE EVM FAILS TO PERFORM AS DESCRIBED OR EXPECTED.
8. *Limitations on Damages and Liability:*
- 8.1 *General Limitations.* IN NO EVENT SHALL TI BE LIABLE FOR ANY SPECIAL, COLLATERAL, INDIRECT, PUNITIVE, INCIDENTAL, CONSEQUENTIAL, OR EXEMPLARY DAMAGES IN CONNECTION WITH OR ARISING OUT OF THESE TERMS AND CONDITIONS OR THE USE OF THE EVMS PROVIDED HEREUNDER, REGARDLESS OF WHETHER TI HAS BEEN ADVISED OF THE POSSIBILITY OF SUCH DAMAGES. EXCLUDED DAMAGES INCLUDE, BUT ARE NOT LIMITED TO, COST OF REMOVAL OR REINSTALLATION, ANCILLARY COSTS TO THE PROCUREMENT OF SUBSTITUTE GOODS OR SERVICES, RETESTING, OUTSIDE COMPUTER TIME, LABOR COSTS, LOSS OF GOODWILL, LOSS OF PROFITS, LOSS OF SAVINGS, LOSS OF USE, LOSS OF DATA, OR BUSINESS INTERRUPTION. NO CLAIM, SUIT OR ACTION SHALL BE BROUGHT AGAINST TI MORE THAN ONE YEAR AFTER THE RELATED CAUSE OF ACTION HAS OCCURRED.
- 8.2 *Specific Limitations.* IN NO EVENT SHALL TI'S AGGREGATE LIABILITY FROM ANY WARRANTY OR OTHER OBLIGATION ARISING OUT OF OR IN CONNECTION WITH THESE TERMS AND CONDITIONS, OR ANY USE OF ANY TI EVM PROVIDED HEREUNDER, EXCEED THE TOTAL AMOUNT PAID TO TI FOR THE PARTICULAR UNITS SOLD UNDER THESE TERMS AND CONDITIONS WITH RESPECT TO WHICH LOSSES OR DAMAGES ARE CLAIMED. THE EXISTENCE OF MORE THAN ONE CLAIM AGAINST THE PARTICULAR UNITS SOLD TO USER UNDER THESE TERMS AND CONDITIONS SHALL NOT ENLARGE OR EXTEND THIS LIMIT.
9. *Return Policy.* Except as otherwise provided, TI does not offer any refunds, returns, or exchanges. Furthermore, no return of EVM(s) will be accepted if the package has been opened and no return of the EVM(s) will be accepted if they are damaged or otherwise not in a resalable condition. If User feels it has been incorrectly charged for the EVM(s) it ordered or that delivery violates the applicable order, User should contact TI. All refunds will be made in full within thirty (30) working days from the return of the components(s), excluding any postage or packaging costs.
10. *Governing Law:* These terms and conditions shall be governed by and interpreted in accordance with the laws of the State of Texas, without reference to conflict-of-laws principles. User agrees that non-exclusive jurisdiction for any dispute arising out of or relating to these terms and conditions lies within courts located in the State of Texas and consents to venue in Dallas County, Texas. Notwithstanding the foregoing, any judgment may be enforced in any United States or foreign court, and TI may seek injunctive relief in any United States or foreign court.

Mailing Address: Texas Instruments, Post Office Box 655303, Dallas, Texas 75265
Copyright © 2015, Texas Instruments Incorporated

IMPORTANT NOTICE

Texas Instruments Incorporated and its subsidiaries (TI) reserve the right to make corrections, enhancements, improvements and other changes to its semiconductor products and services per JESD46, latest issue, and to discontinue any product or service per JESD48, latest issue. Buyers should obtain the latest relevant information before placing orders and should verify that such information is current and complete. All semiconductor products (also referred to herein as "components") are sold subject to TI's terms and conditions of sale supplied at the time of order acknowledgment.

TI warrants performance of its components to the specifications applicable at the time of sale, in accordance with the warranty in TI's terms and conditions of sale of semiconductor products. Testing and other quality control techniques are used to the extent TI deems necessary to support this warranty. Except where mandated by applicable law, testing of all parameters of each component is not necessarily performed.

TI assumes no liability for applications assistance or the design of Buyers' products. Buyers are responsible for their products and applications using TI components. To minimize the risks associated with Buyers' products and applications, Buyers should provide adequate design and operating safeguards.

TI does not warrant or represent that any license, either express or implied, is granted under any patent right, copyright, mask work right, or other intellectual property right relating to any combination, machine, or process in which TI components or services are used. Information published by TI regarding third-party products or services does not constitute a license to use such products or services or a warranty or endorsement thereof. Use of such information may require a license from a third party under the patents or other intellectual property of the third party, or a license from TI under the patents or other intellectual property of TI.

Reproduction of significant portions of TI information in TI data books or data sheets is permissible only if reproduction is without alteration and is accompanied by all associated warranties, conditions, limitations, and notices. TI is not responsible or liable for such altered documentation. Information of third parties may be subject to additional restrictions.

Resale of TI components or services with statements different from or beyond the parameters stated by TI for that component or service voids all express and any implied warranties for the associated TI component or service and is an unfair and deceptive business practice. TI is not responsible or liable for any such statements.

Buyer acknowledges and agrees that it is solely responsible for compliance with all legal, regulatory and safety-related requirements concerning its products, and any use of TI components in its applications, notwithstanding any applications-related information or support that may be provided by TI. Buyer represents and agrees that it has all the necessary expertise to create and implement safeguards which anticipate dangerous consequences of failures, monitor failures and their consequences, lessen the likelihood of failures that might cause harm and take appropriate remedial actions. Buyer will fully indemnify TI and its representatives against any damages arising out of the use of any TI components in safety-critical applications.

In some cases, TI components may be promoted specifically to facilitate safety-related applications. With such components, TI's goal is to help enable customers to design and create their own end-product solutions that meet applicable functional safety standards and requirements. Nonetheless, such components are subject to these terms.

No TI components are authorized for use in FDA Class III (or similar life-critical medical equipment) unless authorized officers of the parties have executed a special agreement specifically governing such use.

Only those TI components which TI has specifically designated as military grade or "enhanced plastic" are designed and intended for use in military/aerospace applications or environments. Buyer acknowledges and agrees that any military or aerospace use of TI components which have **not** been so designated is solely at the Buyer's risk, and that Buyer is solely responsible for compliance with all legal and regulatory requirements in connection with such use.

TI has specifically designated certain components as meeting ISO/TS16949 requirements, mainly for automotive use. In any case of use of non-designated products, TI will not be responsible for any failure to meet ISO/TS16949.

Products

Audio	www.ti.com/audio
Amplifiers	amplifier.ti.com
Data Converters	dataconverter.ti.com
DLP® Products	www.dlp.com
DSP	dsp.ti.com
Clocks and Timers	www.ti.com/clocks
Interface	interface.ti.com
Logic	logic.ti.com
Power Mgmt	power.ti.com
Microcontrollers	microcontroller.ti.com
RFID	www.ti-rfid.com
OMAP Applications Processors	www.ti.com/omap
Wireless Connectivity	www.ti.com/wirelessconnectivity

Applications

Automotive and Transportation	www.ti.com/automotive
Communications and Telecom	www.ti.com/communications
Computers and Peripherals	www.ti.com/computers
Consumer Electronics	www.ti.com/consumer-apps
Energy and Lighting	www.ti.com/energy
Industrial	www.ti.com/industrial
Medical	www.ti.com/medical
Security	www.ti.com/security
Space, Avionics and Defense	www.ti.com/space-avionics-defense
Video and Imaging	www.ti.com/video

TI E2E Community

e2e.ti.com