

PRODUCT NUMBER
66950-XXX

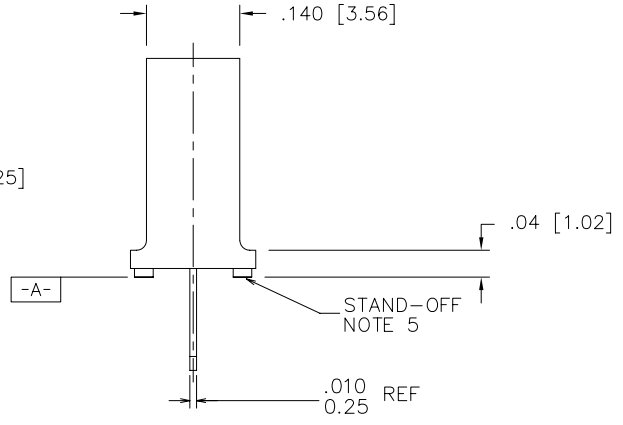
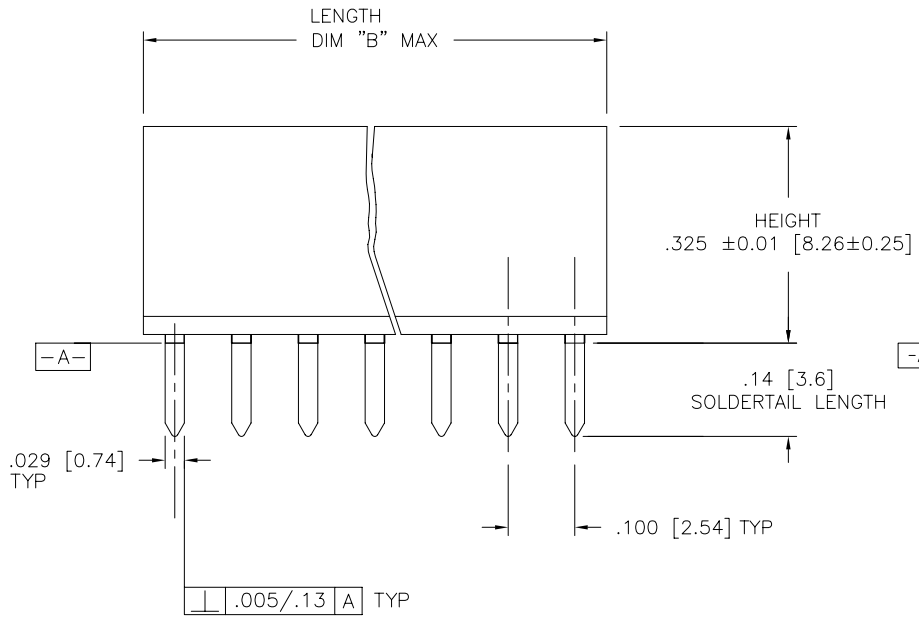
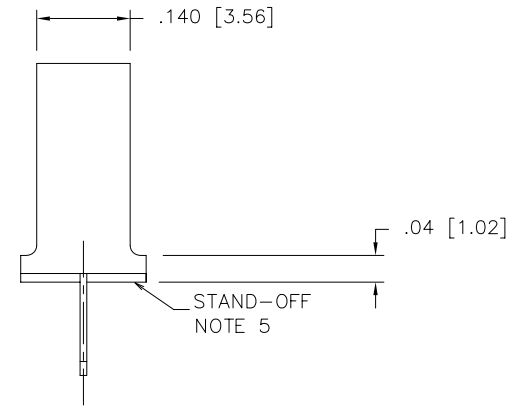
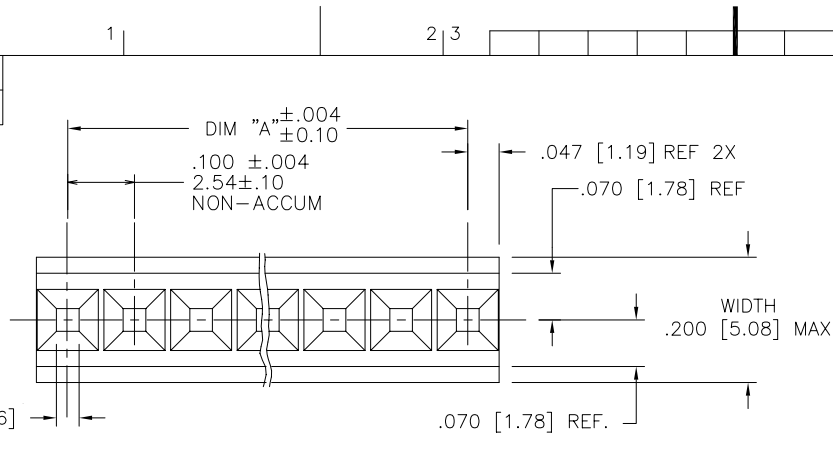

Copyright FCI

mat'l. code NOTES 1 & 2		surface ISO 1302 ✓		tolerance ISO 406 ISO 1101		projection INCH/MM		product family CARD CONN	
ltr		ecn no dr		date		tolerances unless otherwise specified		title	
D	V11848	JGS	7/12/91	angles	linear	.XX±.01/.X±.3	INCH/MM	VERTICAL CARD CONN.	
E	V23245	MRC	10/13/92			.XXX±.0.005/.XX±.13		.100/2.54 CTR. SINGLE. ROW	
F	V70788	LSS	6/223/97	0'±2'		.XXXX±.0020/.XXX±.051	scale 1:4	dwg no sheet 1 of 3 size	
G	v94468	MDF	12/27/99	dr	J.SHREINER	7/12/91		66950 A3	
H	M05-0216	ERE	10/11/05	enr	M.HAHN	7/12/91		type Product Customer Drawing	
J	M06-0210	MHT	6/03/06	chr	M.HAHN	7/12/91			
				appd	M.HAHN	7/12/91			
sheet index	revision sheet	J	J	J					
		1	2	3					

form: A3

PRODUCT NUMBER
SEE TABLE

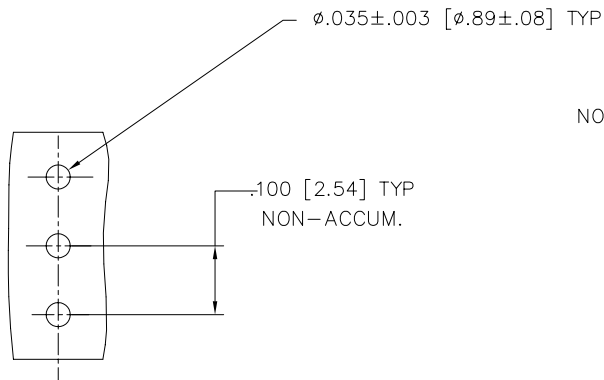

FIGURE "A"
SCALE 4:1

NOTES.

- ① HOUSING MATERIAL: FILLED POLYESTER,
FLAME RETARDANT PER UL 94V-0.
COLOR: BLACK.
- ② TERMINAL MATERIAL:
BODY: BRASS
SPRING: BeCu. HEAT TREATED
BODY PLATING: 15u" [.38u] Au OVER 50u" [1.27]u Ni IN CONTACT AREA
SPRING PLATING: GOLD FLASH
3. MARKING: FCI PART NUMBER AND DATE CODE LEGIBLE ON TUBE LABEL.
4. APPLICATION INFORMATION:
A. RECOMMENDED MOUNTING HOLE PATTERN IS SHOWN IN FIGURE A.
B. ALL MATING PINS TO BE .025 [.64] SQUARE ON TRUE CENTER OF GIVEN TERMINAL SPACINGS, WITHIN .015 [.38] DIAMETER.
C. SUGGESTED MATING PIN LENGTH, .210 ±.020 [5.33 ±.51].
- ⑤ STAND-OFF CONFIGURATION BUMP OR RIB, AT MANUFACTURERS' OPTION.
- ⑥ ADD "LF" SUFFIX AT THE END OF PART NUMBER FOR LEAD FREE OPTION.
- ⑦ THESE PRODUCTS MEET EUROPEAN UNION DIRECTIVES AND OTHER COUNTRY REGULATIONS AS DESCRIBED IN GS-22-008.
8. THIS PART WILL WITHSTAND EXPOSURE TO 260°C PEAK TEMPERATURE FOR 20 SECONDS IN WAVE SOLDER, INFRA-RED OR VAPOR PHASE SOLDER PROCESS.



Copyright FCI

mat'l. code		surface ISO 1302 ✓		tolerance ISO 406 ISO 1101		projection 		product family CARD CONN	
ltr	ecn	no	dr	date	tolerances unless otherwise specified		title		
J					angles	linear	INCH/MM		VERTICAL CARD CONN.
					0°±2'	.XX±.01/.X±.3 .XXX±.0.005/.XX±.13 .XXXX±.0020/.XXX±.051	scale 1:4		.100/2.54 CTR. SINGLE. ROW
			dr	J.SHREINER	7/12/91			dwg no	
			enr	M.HAHN	7/12/91			sheet 2 of 3	
			chr	M.HAHN	7/12/91			66950	
			appd	M.HAHN	7/12/91			A3	
sheet index	revision sheet							type Product Customer Drawing	

PRODUCT NO.	NO OF POSITIONS	DIM A	DIM B	LEAD FREE OPTION
66950-001	U N A S S I G N E D			
-002	1 X 2	.100/2.54	.200/5.08	NOTE 6,7
-003	1 X 3	.200/5.08	.300/7.62	
-004	1 X 4	.300/7.62	.400/10.16	
-005	1 X 5	.400/10.16	.500/12.70	
-006	1 X 6	.500/12.70	.600/15.24	
-007	1 X 7	.600/15.24	.700/17.78	
-008	1 X 8	.700/17.78	.800/20.32	
-009	1 X 9	.800/20.32	.900/22.86	
-010	1 X 10	.900/22.86	1.000/25.40	
-011	1 X 11	1.000/25.40	1.100/27.94	
-012	1 X 12	1.100/27.94	1.200/30.48	
-013	1 X 13	1.200/30.48	1.300/33.02	
-014	1 X 14	1.300/33.02	1.400/35.56	
-015	1 X 15	1.400/35.56	1.500/38.10	
-016	1 X 16	1.500/38.10	1.600/40.64	
-017	1 X 17	1.600/40.64	1.700/43.18	
-018	1 X 18	1.700/43.18	1.800/45.72	
-019	1 X 19	1.800/45.72	1.900/48.26	
-020	1 X 20	1.900/48.26	2.000/50.80	
-021	1 X 21	2.000/50.80	2.100/53.34	
-022	1 X 22	2.100/53.34	2.200/55.88	
-023	1 X 23	2.200/55.88	2.300/58.42	
-024	1 X 24	2.300/58.42	2.400/60.96	
-025	1 X 25	2.400/60.96	2.500/63.50	
-026	1 X 26	2.500/63.50	2.600/66.04	
-027	1 X 27	2.600/66.04	2.700/68.58	
-028	1 X 28	2.700/68.58	2.800/71.12	
-029	1 X 29	2.800/71.12	2.900/73.66	
-030	1 X 30	2.900/73.66	3.000/76.20	
-031	1 X 31	3.000/76.20	3.100/78.74	
-032	1 X 32	3.100/78.74	3.200/81.28	
-033	1 X 33	3.200/81.28	3.300/83.82	
-034	1 X 34	3.300/83.82	3.400/86.36	
-035	1 X 35	3.400/86.36	3.500/88.90	
66950-036	1 X 36	3.500/88.90	3.600/91.44	

OBS



Copyright FCJ

mat'l. code		surface ISO 1302 <input checked="" type="checkbox"/>		tolerance ISO 406 ISO 1101		projection 		product family CARD CONN	
ltr	ecn no	dr	date	tolerances unless otherwise specified				title	
J				angles	linear	.XX±.01/.X±.3		VERTICAL CARD CONN.	
				0'±2'		.XXX±.0.005/.XX±.13		.100/2.54 CTR. SINGLE. ROW	
						.XXXX±.0020/.XXX±.051		scale 1:4	
				dr	J.SHREINER	7/12/91		dwg no	
				enr	M.HAHN	7/12/91		sheet 3 of 3 size	
				chr	M.HAHN	7/12/91		66950 A3	
				appd	M.HAHN	7/12/91		type Product Customer Drawing	
sheet index	revision sheet								

