

PROD	LOC	DIST	P	F	ZONE	LTR	DESCRIPTION	DATE	APPD
4085	DF	50				B	REV & REDRAWN; 0600-3588-95 CT	3-95	CS

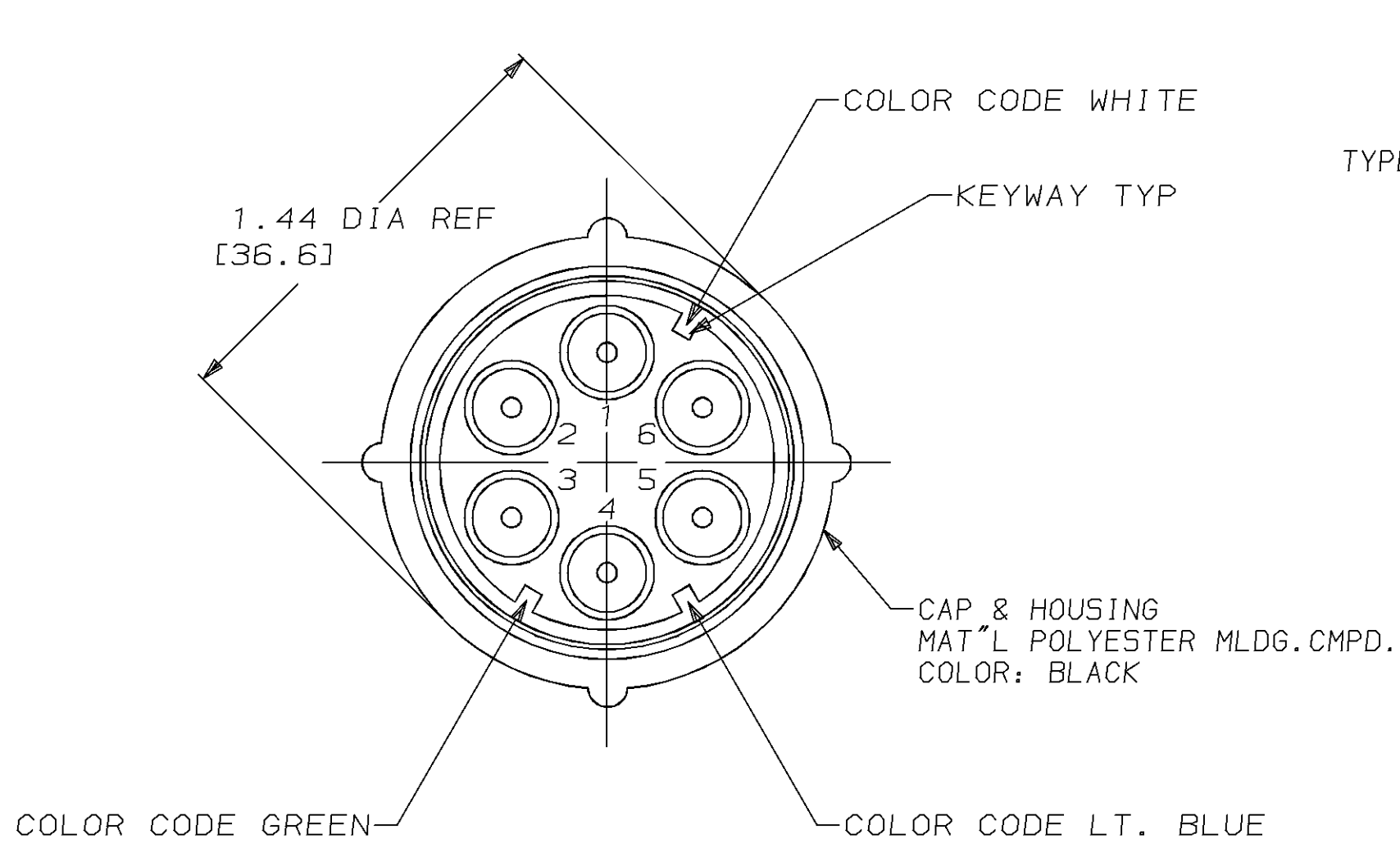

△ PIN: TYPE II (QTY=6)  
 GOLD PLATED PER MIL-G-45204  
 TYPE II .000050 [0.00127] MIN THK

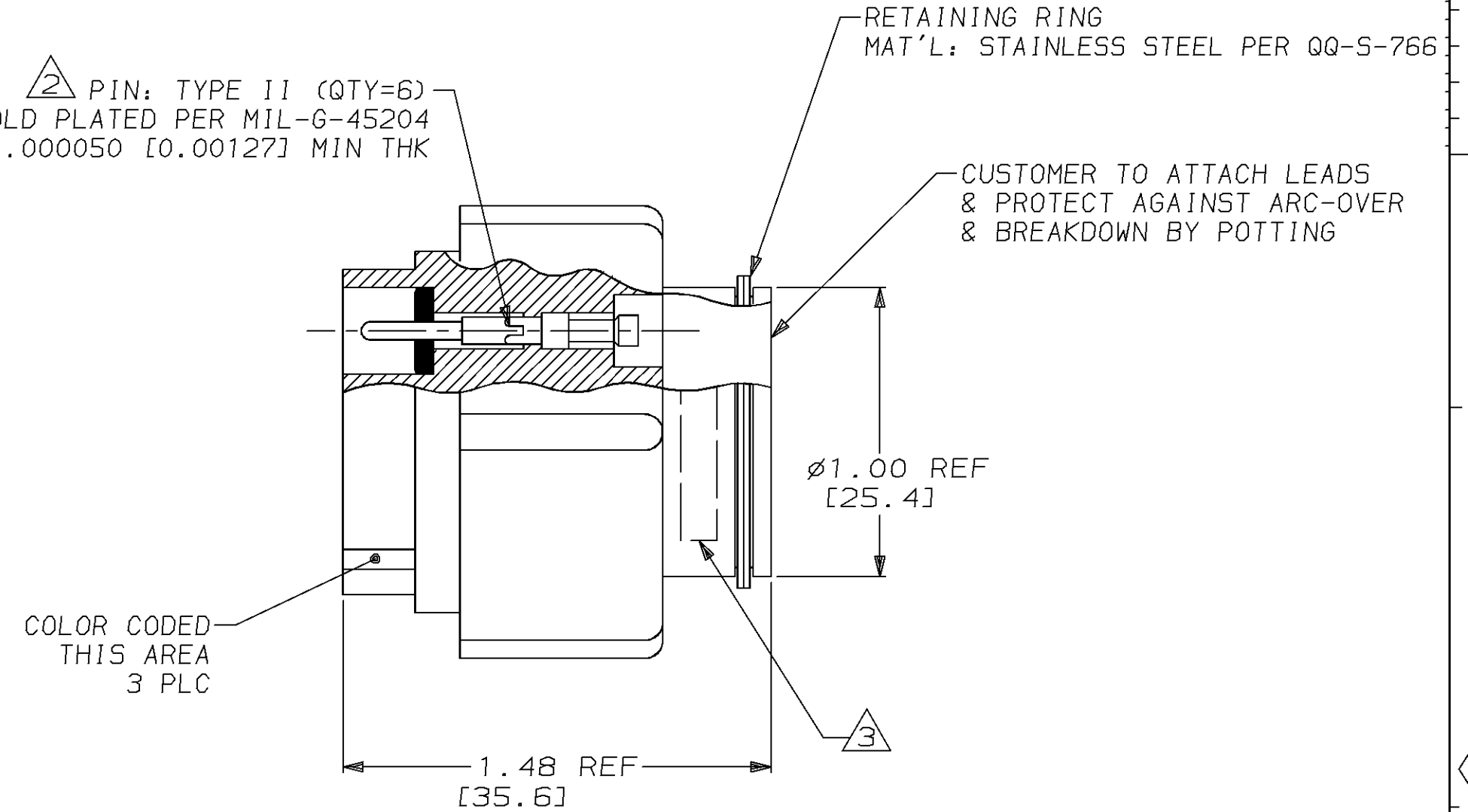

1. PLUG ASS'Y WILL WITHSTAND WITHOUT BREAKDOWN 27 KVDC PIN TO PIN & 27 KVDC PIN TO GROUND WHEN MATED WITH RECEPT.
- △ 2 TYPE II PINS TO ACCEPT (1) 20 AWG, (1) 22 AWG, OR (1) 24 AWG STRANDED WIRE. USE AMP HAND TOOL #45099.
- △ 3 MARKED PER MIL-STD-130 WITH WHITE INK (AMP INFO).
4. PLUGS AND PINS TO BE PACKAGED SEPARATELY.
5. TO REMOVE PINS USE EXTRACTION TOOL #861751-1.

	155336	YES	20,22,24	868384-2
SUPERSEDED BY 868384-2	A166866	YES	20,22,24	868384-1
	CUST P/N	COLOR CODE	RANGE WIRE SIZE	PART NO.

DO NOT SCALE PRINT. UNLESS SPECIFIED DIMENSIONS IN INCHES [mm] TOLERANCES ON : 2 PLC DEC ± - 3 PLC DEC ± - ANGLES ± -	DR 3-31-95 C.C. THOMAS	AMP Incorporated Harrisburg, PA 17105-3608		
	CHK 3-31-95 C.SHELLY			
MATERIAL SEE CALLOUT	APPD 3-31-95 C.SHELLY	NAME PLUG KIT, LGH, 6 POSN.		
FINISH SEE CALLOUT	APPD 3-31-95 C.C. THOMAS	SIZE C	CAGE CODE 00779	DRAWING NO C=868384
	PRODUCT SPEC -	SCALE 2:1	SHEET 1 OF 1	
	APPLICATION SPEC -			
	WEIGHT -			

THIS DRAWING IS A CONTROLLED DOCUMENT FOR AMP INCORPORATED. IT IS SUBJECT TO CHANGE AND THE CONTROLLING ENGINEERING ORGANIZATION SHOULD BE CONTACTED FOR THE LATEST REVISION.