

**NOT RECOMMENDED FOR NEW DESIGNS  
RECOMMENDED REPLACEMENT PART  
ISL43L210**

**Ultra Low ON-Resistance, Single Supply, Differential SPST Analog Switches**

The Intersil ISL43L710, ISL43L711, ISL43L712 devices are low ON-resistance, low voltage, bidirectional, precision, differential single-pole/single-throw (SPST) analog switches designed to operate from a single +1.65V to +3.6V supply. Targeted applications include battery powered equipment that benefit from low R<sub>ON</sub> (0.16Ω), low power consumption (0.12μW) and fast switching speeds (t<sub>ON</sub> = 13ns, t<sub>OFF</sub> = 13ns).

Cell phones, for example, often face ASIC functionality limitations. The number of analog input or GPIO pins may be limited and digital geometries are not well suited to analog switch performance. This family of parts may be used to switch in additional functionality while reducing ASIC design risk. The ISL43L71X are offered in small form factor packages, alleviating board space limitations.

The ISL43L710, ISL43L711, ISL43L712 are differential single-pole/single-throw (SPST) devices. The ISL43L710 has two normally open (NO) switches; the ISL43L711 has two normally closed (NC) switches; the ISL43L712 has one normally open (NO) and one normally closed (NC) switch and can be used as an SPDT. The ISL43L712 is equipped with an inhibit pin to simultaneously open all signal paths.

Table 1 summarizes the performance of this family.

**TABLE 1. FEATURES AT A GLANCE**

	ISL43L710	ISL43L711	ISL43L712
<b>NUMBER OF SWITCHES</b>	2	2	2
<b>SW 1/SW 2</b>	NO/NO	NC/NC	NO/NC
<b>1.8V R<sub>ON</sub></b>	0.26Ω	0.26Ω	0.26Ω
<b>1.8V t<sub>ON</sub>/t<sub>OFF</sub></b>	30ns/25ns	30ns/25ns	30ns/25ns
<b>3V R<sub>ON</sub></b>	0.16Ω	0.16Ω	0.16Ω
<b>3V t<sub>ON</sub>/t<sub>OFF</sub></b>	13ns/13ns	13ns/13ns	13ns/13ns
<b>PACKAGES</b>	8 Ld 3x3 thin DFN, 8 Ld MSOP		

**Related Literature**

Technical Brief TB363 “Guidelines for Handling and Processing Moisture Sensitive Surface Mount Devices (SMDs)”.

Application Note AN557 “Recommended Test Procedures for Analog Switches”.

**Features**

- Pb-Free Available (RoHS Compliant) (See Ordering info)
- Low ON Resistance (R<sub>ON</sub>)
  - V+ = 3.0V ..... 0.16Ω
  - V+ = 1.8V ..... 0.26Ω
- R<sub>ON</sub> Matching Between Channels ..... 0.005Ω
- R<sub>ON</sub> Flatness Over Signal Range ..... 0.008Ω
- Single Supply Operation ..... +1.65V to +3.6V
- Low Power Consumption (P<sub>D</sub>) ..... <0.12μW
- Fast Switching Action (V+ = 3.0V)
  - t<sub>ON</sub> ..... 13ns
  - t<sub>OFF</sub> ..... 13ns
- ESD HBM Rating ..... >8kV
- 1.8V Logic Compatible (+3V Supply)
- Available in 8 Ld TDFN and 8 Ld MSOP Packages

**Applications**

- Battery Powered, Handheld, and Portable Equipment
  - Cellular/Mobile Phones
  - Pagers
  - Laptops, Notebooks, Palmtops
- Portable Test and Measurement
- Medical Equipment
- Audio and Video Switching

**Truth Table**

LOGIC		ISL43L710	ISL43L711
		SW 1, 2	SW 1, 2
0		OFF	ON
1		ON	OFF
INH	LOGIC	ISL43L712	
		SW 1	SW 2
1	X	OFF	OFF
0	0	OFF	ON
0	1	ON	OFF

NOTE:

1. Logic “0” ≤ 0.5V. Logic “1” ≥ 1.4V with a 3V Supply.

# ISL43L710, ISL43L711, ISL43L712

## Pinouts (Note 2)

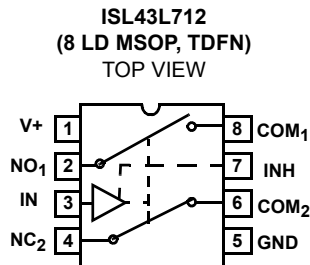
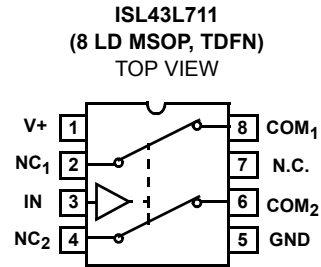
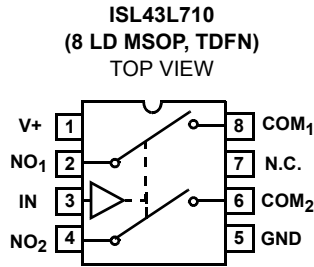

NOTE:

- Switches Shown for Logic "0" Input.

## Ordering Information

PART NUMBER (Note 3)	PART MARKING	TEMP. RANGE (°C)	PACKAGE	PKG. DWG. #
ISL43L710IU	L710	-40 to +85	8 Ld MSOP	M8.118
ISL43L710IUZ (Note 4)	L710Z	-40 to +85	8 Ld MSOP (Pb-free)	M8.118
ISL43L710IR	L71	-40 to +85	8 Ld 3x3 TDFN	L8.3x3A
ISL43L711IU	L711	-40 to +85	8 Ld MSOP	M8.118
ISL43L711IR	L71	-40 to +85	8 Ld 3x3 TDFN	L8.3x3A
ISL43L712IU	L712	-40 to +85	8 Ld MSOP	M8.118
ISL43L712IR	L72	-40 to +85	8 Ld 3x3 TDFN	L8.3x3A
ISL43L712IUZ (Note 4)	L712Z	-40 to +85	8 Ld MSOP (Pb-free)	M8.118
ISL43L712IRZ (Note 4)	L72Z	-40 to +85	8 Ld 3x3 TDFN (Pb-free)	L8.3x3A

NOTES:

- Add "-T" suffix for tape and reel. Please refer to TB347 for details on reel specifications.
- These Intersil Pb-free plastic packaged products employ special Pb-free material sets, molding compounds/die attach materials, and 100% matte tin plate plus anneal (e3 termination finish, which is RoHS compliant and compatible with both SnPb and Pb-free soldering operations). Intersil Pb-free products are MSL classified at Pb-free peak reflow temperatures that meet or exceed the Pb-free requirements of IPC/JEDEC J STD-020.

## Pin Descriptions

PIN	FUNCTION
V+	System Power Supply Input (+1.65V to +3.6V)
GND	Ground Connection
IN	Digital Control Input
COM	Analog Switch Common Pin
NO	Analog Switch Normally Open Pin
NC	Analog Switch Normally Closed Pin
INH	Digital Control Input. Connect to GND for Normal Operation. Connect to V+ to turn all switches off.
N.C.	No Connect

# ISL43L710, ISL43L711, ISL43L712

## Absolute Maximum Ratings

V+ to GND	-0.3 to 4.7V
Input Voltages	
IN (Note 5)	-0.3 to ((V+) + 0.3V)
NO, NC (Note 5)	-0.3 to ((V+) + 0.3V)
Output Voltages	
COM (Note 5)	-0.3 to ((V+) + 0.3V)
Continuous Current (Any Terminal)	300mA
Peak Current, IN, NO, NC, or COM (Pulsed 1ms, 10% Duty Cycle, Max)	500mA
ESD Rating (Per MIL-STD-883 Method 3015)	>8kV

## Thermal Information

Thermal Resistance (Typical, Note 6)	$\theta_{JA}$ (°C/W)
8 Ld 3x3 thin DFN Package	110
8 Ld MSOP Package	190
Maximum Junction Temperature (Plastic Package)	+150°C
Maximum Storage Temperature Range	-65°C to +150°C
Maximum Lead Temperature (Soldering 10s) (Lead Tips Only)	+300°C

## Operating Conditions

Temperature Range . . . . . -40°C to +85°C

*CAUTION: Stresses above those listed in "Absolute Maximum Ratings" may cause permanent damage to the device. This is a stress only rating and operation of the device at these or any other conditions above those indicated in the operational sections of this specification is not implied.*

### NOTES:

- Signals on NC, NO, COM, or IN exceeding V+ or GND are clamped by internal diodes. Limit forward diode current to maximum current ratings.
- $\theta_{JA}$  is measured with the component mounted on a low effective thermal conductivity test board in free air. See Tech Brief TB379 for details.

## Electrical Specifications - 3V Supply

Test Conditions: V+ = +2.7V to +3.3V, GND = 0V,  $V_{INH} = 1.4V$ ,  $V_{INL} = 0.5V$  (Note 7),  
Unless Otherwise Specified

PARAMETER	TEST CONDITIONS	TEMP (°C)	MIN (Notes 8, 9)	TYP	MAX (Notes 8, 9)	UNITS
<b>ANALOG SWITCH CHARACTERISTICS</b>						
Analog Signal Range, $V_{ANALOG}$		Full	0	-	V+	V
ON Resistance, $R_{ON}$	V+ = 2.7V, $I_{COM} = 100mA$ , $V_{NO}$ or $V_{NC} = 0V$ to V+ (See Figure 4)	25	-	0.17	0.25	$\Omega$
		Full	-	-	0.3	$\Omega$
$R_{ON}$ Matching Between Channels, $\Delta R_{ON}$	V+ = 2.7V, $I_{COM} = 100mA$ , $V_{NO}$ or $V_{NC} =$ Voltage at Max $R_{ON}$ , (Note 11)	25	-	0.005	0.02	$\Omega$
		Full	-	-	0.04	$\Omega$
$R_{ON}$ Flatness, $R_{Flat(ON)}$	V+ = 2.7V, $I_{COM} = 100mA$ , $V_{NO}$ or $V_{NC} = 0V$ to V+, (Note 12)	25	-	0.008	0.06	$\Omega$
		Full	-	-	0.07	$\Omega$
NO or NC OFF Leakage Current, $I_{NO(OFF)}$ or $I_{NC(OFF)}$	V+ = 3.3V, $V_{COM} = 0.3, 3V$ , $V_{NO}$ or $V_{NC} = 3V, 0.3V$	25	-3	-	3	nA
		Full	-60	-	60	nA
COM ON Leakage Current, $I_{COM(ON)}$	V+ = 3.3V, $V_{COM} = 0.3V, 3V$ , or $V_{NO}$ or $V_{NC} = 0.3V, 3V$	25	-3	-	3	nA
		Full	-80	-	80	nA
<b>DYNAMIC CHARACTERISTICS</b>						
Turn-ON Time, $t_{ON}$	V+ = 2.7V, $V_{NO}$ or $V_{NC} = 1.5V$ , $R_L = 50\Omega$ , $C_L = 35pF$ , $V_{IN} = 0$ to 2.7V, (See Figure 1, Note 10)	25	-	15	25	ns
		Full	-	-	30	ns
Turn-OFF Time, $t_{OFF}$	V+ = 2.7V, $V_{NO}$ or $V_{NC} = 1.5V$ , $R_L = 50\Omega$ , $C_L = 35pF$ , $V_{IN} = 0$ to 2.7V, (See Figure 1, Note 10)	25	-	15	25	ns
		Full	-	-	30	ns
Charge Injection, Q	$C_L = 1.0nF$ , $V_G = 0V$ , $R_G = 0\Omega$ , (See Figure 2)	25	-	-125	-	pC
OFF Isolation	$R_L = 50\Omega$ , $C_L = 5pF$ , $f = 100kHz$ , $V_{COM} = 1 V_{RMS}$ , (See Figure 3)	25	-	62	-	dB
Crosstalk (Channel-to-Channel)	$R_L = 50\Omega$ , $C_L = 5pF$ , $f = 100kHz$ , $V_{COM} = 1 V_{RMS}$ , (See Figure 5)	25	-	-94	-	dB
NO or NC OFF Capacitance, $C_{OFF}$	$f = 1MHz$ , $V_{NO}$ or $V_{NC} = V_{COM} = 0V$ , (See Figure 6)	25	-	182	-	pF
COM OFF Capacitance, $C_{COM(OFF)}$	$f = 1MHz$ , $V_{NO}$ or $V_{NC} = V_{COM} = 0V$ , (See Figure 6)	25	-	182	-	pF
COM ON Capacitance, $C_{COM(ON)}$	$f = 1MHz$ , $V_{NO}$ or $V_{NC} = V_{COM} = 0V$ , (See Figure 6)	25	-	290	-	pF

## ISL43L710, ISL43L711, ISL43L712

### Electrical Specifications - 3V Supply

Test Conditions:  $V_+ = +2.7V$  to  $+3.3V$ ,  $GND = 0V$ ,  $V_{INH} = 1.4V$ ,  $V_{INL} = 0.5V$  (Note 7),  
Unless Otherwise Specified (Continued)

PARAMETER	TEST CONDITIONS	TEMP (°C)	MIN (Notes 8, 9)	TYP	MAX (Notes 8, 9)	UNITS
<b>POWER SUPPLY CHARACTERISTICS</b>						
Power Supply Range		Full	1.65	-	3.6	V
Positive Supply Current, $I_+$	$V_+ = 1.65V$ to $3.6V$ , $V_{IN} = 0V$ or $V_+$ , all channels on or off	25	-	-	30	nA
		Full	-	-	750	nA
<b>DIGITAL INPUT CHARACTERISTICS</b>						
Input Voltage Low, $V_{INL}$		Full	-	-	0.5	V
Input Voltage High, $V_{INH}$		Full	1.4	-	-	V
Input Current, $I_{INH}$ , $I_{INL}$	$V_+ = 3.3V$ , $V_{IN} = 0V$ or $V_+$ (Note 10)	Full	-0.5	-	0.5	$\mu A$

**NOTES:**

7.  $V_{IN}$  = input voltage to perform proper function.
8. The algebraic convention, whereby the most negative value is a minimum and the most positive a maximum, is used in this data sheet.
9. Parameters with MIN and/or MAX limits are 100% tested at  $+25^\circ C$ , unless otherwise specified. Temperature limits established by characterization and are not production tested.
10. Limits established by characterization and are not production tested.
11.  $R_{ON}$  matching between channels is calculated by subtracting the channel with the highest max  $R_{on}$  value from the channel with lowest max  $R_{on}$  value.
12. Flatness is defined as the difference between maximum and minimum value of on-resistance over the specified analog signal range.

### Electrical Specifications - 1.8V Supply

Test Conditions:  $V_+ = +1.65V$  to  $+2.0V$ ,  $GND = 0V$ ,  $V_{INH} = 1.0V$ ,  $V_{INL} = 0.4V$  (Note 7),  
Unless Otherwise Specified

PARAMETER	TEST CONDITIONS	TEMP (°C)	MIN (Notes 8, 9)	TYP	MAX (Notes 8, 9)	UNITS
<b>ANALOG SWITCH CHARACTERISTICS</b>						
Analog Signal Range, $V_{ANALOG}$		Full	0	-	$V_+$	V
ON Resistance, $R_{ON}$	$V_+ = 1.8V$ , $I_{COM} = 100mA$ , $V_{NO}$ or $V_{NC} = 0V$ to $V_+$ , (See Figure 4, Note 10)	25	-	0.26	0.35	$\Omega$
		Full	-	-	0.4	$\Omega$
$R_{ON}$ Matching Between Channels, $\Delta R_{ON}$	$V_+ = 1.8V$ , $I_{COM} = 100mA$ , $V_{NO}$ or $V_{NC} =$ Voltage at Max $R_{ON}$ , (Note 11)	25	-	0.005	-	$\Omega$
		Full	-	0.005	-	$\Omega$
$R_{ON}$ Flatness, $R_{FLAT(ON)}$	$V_+ = 1.8V$ , $I_{COM} = 100mA$ , $V_{NO}$ or $V_{NC} = 0V$ to $V_+$ , (Note 12)	25	-	0.074	-	$\Omega$
		Full	-	0.082	-	$\Omega$
NO or NC OFF Leakage Current, $I_{NO(OFF)}$ or $I_{NC(OFF)}$	$V_+ = 2.0V$ , $V_{COM} = 0.3V$ , $1.8V$ , $V_{NO}$ or $V_{NC} = 1.8V$ , $0.3V$	25	-3	-	3	nA
		Full	-60	-	60	nA
COM ON Leakage Current, $I_{COM(ON)}$	$V_+ = 2.0V$ , $V_{COM} = 0.3V$ , $1.8V$ , or $V_{NO}$ or $V_{NC} = 0.3V$ , $1.8V$	25	-3	-	3	nA
		Full	-80	-	80	nA
<b>DYNAMIC CHARACTERISTICS</b>						
Turn-ON Time, $t_{ON}$	$V_+ = 1.65V$ , $V_{NO}$ or $V_{NC} = 1.0V$ , $R_L = 50\Omega$ , $C_L = 35pF$ , $V_{IN} = 0$ to $1.65V$ , (See Figure 1, Note 10)	25	-	30	40	ns
		Full	-	-	45	ns
Turn-OFF Time, $t_{OFF}$	$V_+ = 1.65V$ , $V_{NO}$ or $V_{NC} = 1.0V$ , $R_L = 50\Omega$ , $C_L = 35pF$ , $V_{IN} = 0$ to $1.65V$ , (See Figure 1, Note 10)	25	-	25	35	ns
		Full	-	-	40	ns
Charge Injection, Q	$C_L = 1.0nF$ , $V_G = 0V$ , $R_G = 0\Omega$ , (See Figure 2)	25	-	-80	-	pC
OFF Isolation	$R_L = 50\Omega$ , $C_L = 5pF$ , $f = 100kHz$ , $V_{COM} = 1 V_{RMS}$ , (See Figure 3 and Figure 5)	25	-	62	-	dB
Crosstalk (Channel-to-Channel)		25	-	-94	-	dB

**Electrical Specifications - 1.8V Supply**

Test Conditions:  $V_+ = +1.65V$  to  $+2.0V$ ,  $GND = 0V$ ,  $V_{INH} = 1.0V$ ,  $V_{INL} = 0.4V$  (Note 7), Unless Otherwise Specified (Continued)

PARAMETER	TEST CONDITIONS	TEMP (°C)	MIN (Notes 8, 9)	TYP	MAX (Notes 8, 9)	UNITS
NO or NC OFF Capacitance, $C_{OFF}$	$f = 1MHz$ , $V_{NO}$ or $V_{NC} = V_{COM} = 0V$ , (See Figure 6)	25	-	182	-	pF
COM OFF Capacitance, $C_{COM(OFF)}$	$f = 1MHz$ , $V_{NO}$ or $V_{NC} = V_{COM} = 0V$ , (See Figure 6)	25	-	182	-	pF
COM ON Capacitance, $C_{COM(ON)}$	$f = 1MHz$ , $V_{NO}$ or $V_{NC} = V_{COM} = 0V$ , (See Figure 6)	25	-	290	-	pF
<b>POWER SUPPLY CHARACTERISTICS</b>						
Positive Supply Current, $I_+$	$V_+ = 1.65V$ to $3.6V$ , $V_{IN} = 0V$ or $V_+$ , all channels on or off	25	-	-	30	nA
		Full	-	-	750	nA
<b>DIGITAL INPUT CHARACTERISTICS</b>						
Input Voltage Low, $V_{INL}$		Full	-	-	0.4	V
Input Voltage High, $V_{INH}$		Full	1.0	-	-	V
Input Current, $I_{INH}$ , $I_{INL}$	$V_+ = 2.0V$ , $V_{IN} = 0V$ or $V_+$ (Note 10)	Full	-0.5	-	0.5	$\mu A$

**Test Circuits and Waveforms**

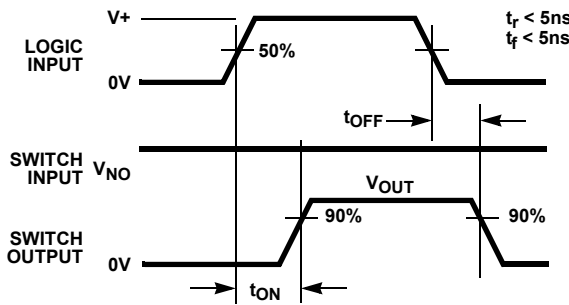

Logic input waveform is inverted for switches that have the opposite logic sense.

FIGURE 1A. MEASUREMENT POINTS

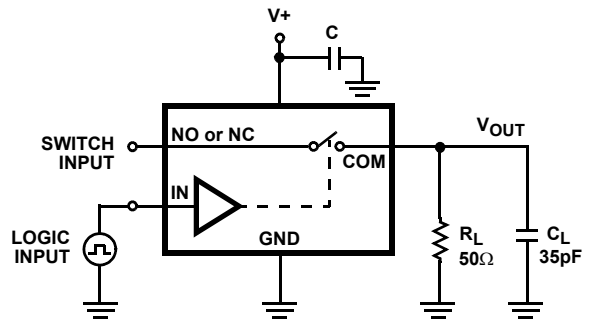

Repeat test for all switches.  $C_L$  includes fixture and stray capacitance.

$$V_{OUT} = V_{(NO\ or\ NC)} \frac{R_L}{R_L + R_{(ON)}}$$

FIGURE 1B. TEST CIRCUIT

FIGURE 1. SWITCHING TIMES

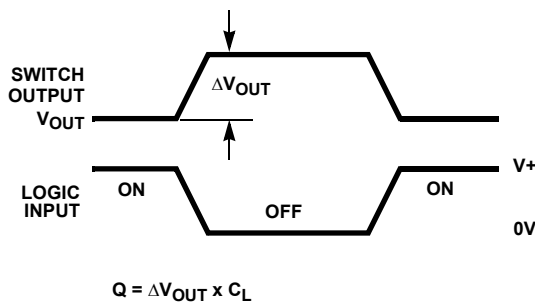

FIGURE 2A. MEASUREMENT POINTS

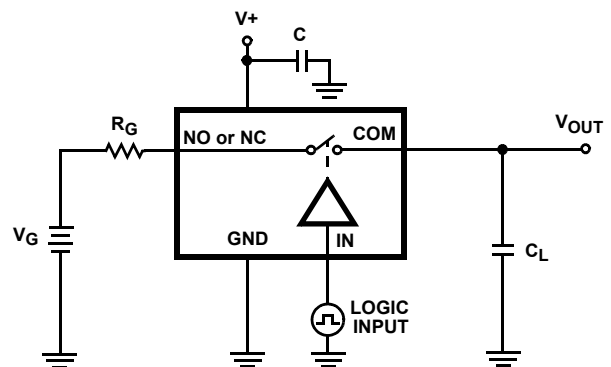

FIGURE 2B. TEST CIRCUIT

FIGURE 2. CHARGE INJECTION

Test Circuits and Waveforms (Continued)

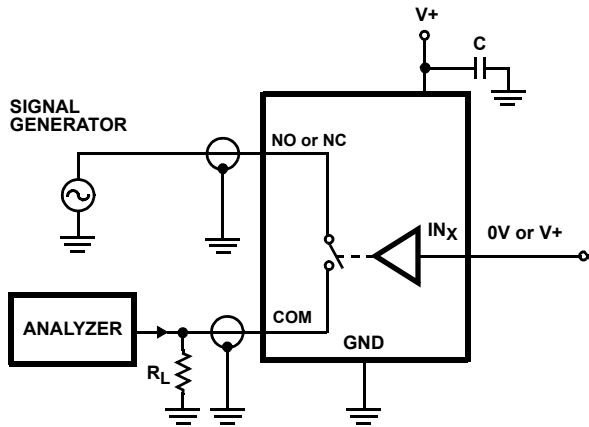

FIGURE 3. OFF ISOLATION TEST CIRCUIT

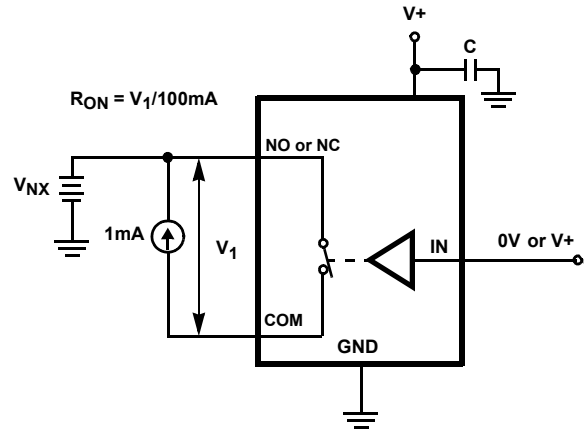

FIGURE 4.  $R_{ON}$  TEST CIRCUIT

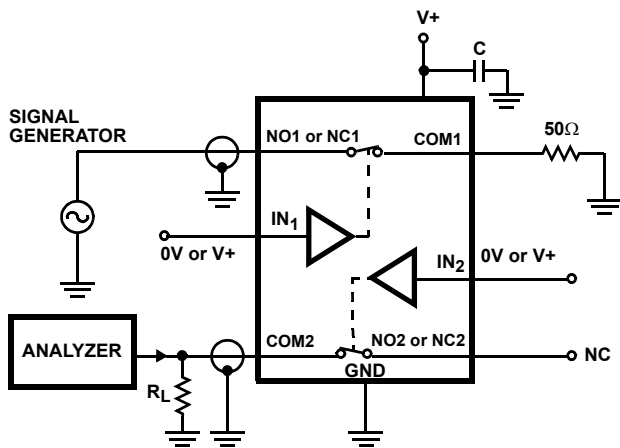

FIGURE 5. CROSSTALK TEST CIRCUIT

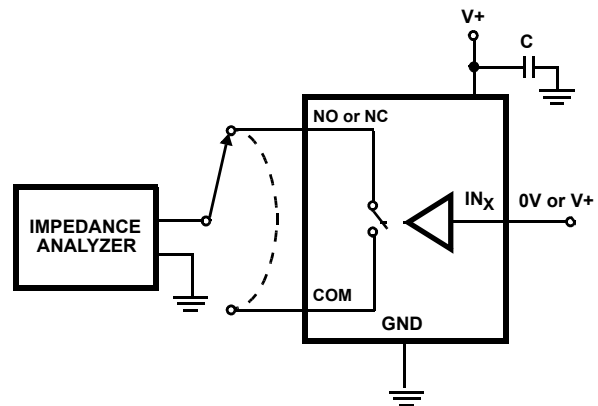

FIGURE 6. CAPACITANCE TEST CIRCUIT

Detailed Description

The ISL43L71x family of devices are bidirectional, single pole/single throw (SPST) analog switches that offer precise switching capability from a single 1.65V to 3.6V supply with low on-resistance ( $0.16\Omega$ ) and high speed operation ( $t_{ON} = 13ns$ ,  $t_{OFF} = 13ns$ ). The device is especially well suited for portable battery powered equipment due to its low operating supply voltage (1.65V), low power consumption ( $2.7\mu W$  max), low leakage currents (80nA max), and the tiny TDFN and MSOP packaging. The ultra low on-resistance and  $R_{ON}$  flatness provide very low insertion loss and distortion to application that require signal reproduction.

Supply Sequencing and Overvoltage Protection

With any CMOS device, proper power supply sequencing is required to protect the device from excessive input currents which might permanently damage the IC. All I/O pins contain ESD protection diodes from the pin to V+ and to GND (See Figure 7). To prevent forward biasing these diodes, V+ must

be applied before any input signals, and the input signal voltages must remain between V+ and GND. If these conditions cannot be guaranteed, then one of the following two protection methods should be employed.

Logic inputs can easily be protected by adding a  $1k\Omega$  resistor in series with the input (See Figure 7). The resistor limits the input current below the threshold that produces permanent damage, and the sub-microamp input current produces an insignificant voltage drop during normal operation.

This method is not acceptable for the signal path inputs. Adding a series resistor to the switch input defeats the purpose of using a low  $R_{ON}$  switch, so two small signal diodes can be added in series with the supply pins to provide overvoltage protection for all pins (See Figure 7). These additional diodes limit the analog signal from 1V below V+ to 1V above GND. The low leakage current performance is

unaffected by this approach, but the switch signal range is reduced and the resistance may increase, especially at low supply voltages.

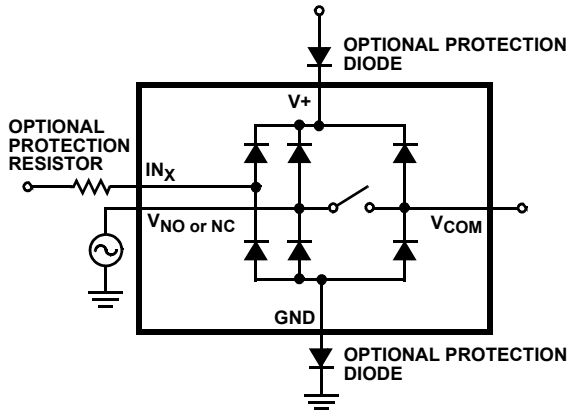

FIGURE 7. OVERVOLTAGE PROTECTION

### Power-Supply Considerations

The ISL43L71x construction is typical of most single supply CMOS analog switches, in that they have two supply pins: V+ and GND. V+ and GND drive the internal CMOS switches and set their analog voltage limits. Unlike switches with a 4V maximum supply voltage, the ISL43L71x 4.7V maximum supply voltage provides plenty of room for the 10% tolerance of 3.6V supplies, as well as room for overshoot and noise spikes.

The minimum recommended supply voltage is 1.65V but the part will operate with a supply below 1.5V. It is important to note that the input signal range, switching times, and on-resistance degrade at lower supply voltages. Refer to the electrical specification tables and *Typical Performance* curves for details.

V+ and GND also power the internal logic and level shifters. The level shifters convert the input logic levels to switched V+ and GND signals to drive the analog switch gate terminals.

This family of switches cannot be operated with bipolar supplies, because the input switching point becomes negative in this configuration.

### Logic-Level Thresholds

This switch family is 1.8V CMOS compatible (0.5V and 1.4V) over a supply range of 2V to 3.6V (See Figure 14). At 3.6V the  $V_{IH}$  level is about 1.27V. This is still below the 1.8V CMOS guaranteed high output minimum level of 1.4V, but noise margin is reduced.

The digital input stages draw supply current whenever the digital input voltage is not at one of the supply rails. Driving the digital input signals from GND to V+ with a fast transition time minimizes power dissipation.

### High-Frequency Performance

In 50Ω systems, signal response is reasonably flat even past 20MHz with a -3dB bandwidth of 175MHz (See Figure 15). The frequency response is very consistent over a wide V+ range, and for varying analog signal levels.

An OFF switch acts like a capacitor and passes higher frequencies with less attenuation, resulting in signal feedthrough from a switch's input to its output. Off Isolation is the resistance to this feedthrough, while Crosstalk indicates the amount of feedthrough from one switch to another. Figure 16 details the high Off Isolation and Crosstalk rejection provided by this family. At 100kHz, Off Isolation is about 62dB in 50Ω systems, decreasing approximately 20dB per decade as frequency increases. Higher load impedances decrease Off Isolation and Crosstalk rejection due to the voltage divider action of the switch OFF impedance and the load impedance.

### Leakage Considerations

Reverse ESD protection diodes are internally connected between each analog-signal pin and both V+ and GND. One of these diodes conducts if any analog signal exceeds V+ or GND.

Virtually all the analog leakage current comes from the ESD diodes to V+ or GND. Although the ESD diodes on a given signal pin are identical and therefore fairly well balanced, they are reverse biased differently. Each is biased by either V+ or GND and the analog signal. This means their leakages will vary as the signal varies. The difference in the two diode leakages to the V+ and GND pins constitutes the analog-signal-path leakage current. All analog leakage current flows between each pin and one of the supply terminals, not to the other switch terminal. This is why both sides of a given switch can show leakage currents of the same or opposite polarity. There is no connection between the analog signal paths and V+ or GND.

Typical Performance Curves  $T_A = +25^\circ\text{C}$ , Unless Otherwise Specified

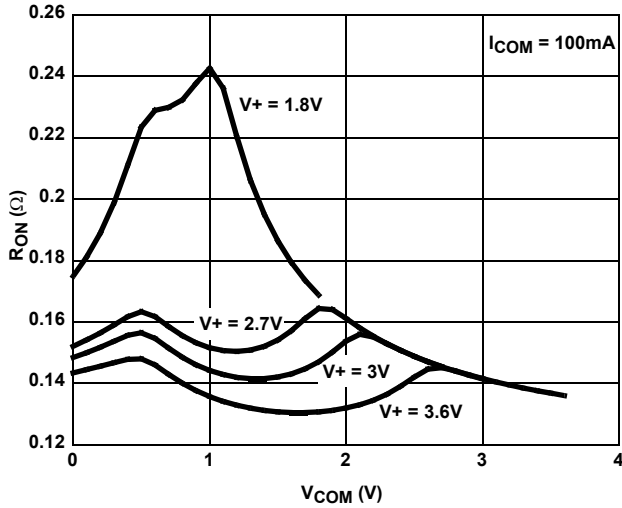

FIGURE 8. ON RESISTANCE vs SUPPLY VOLTAGE vs SWITCH VOLTAGE

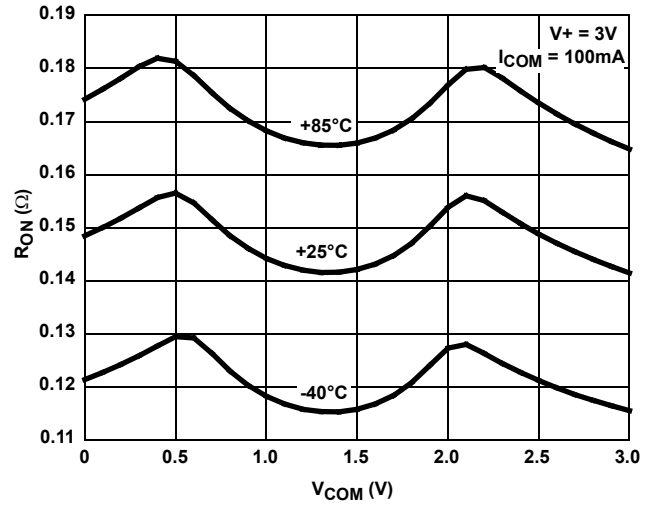

FIGURE 9. ON RESISTANCE vs SWITCH VOLTAGE

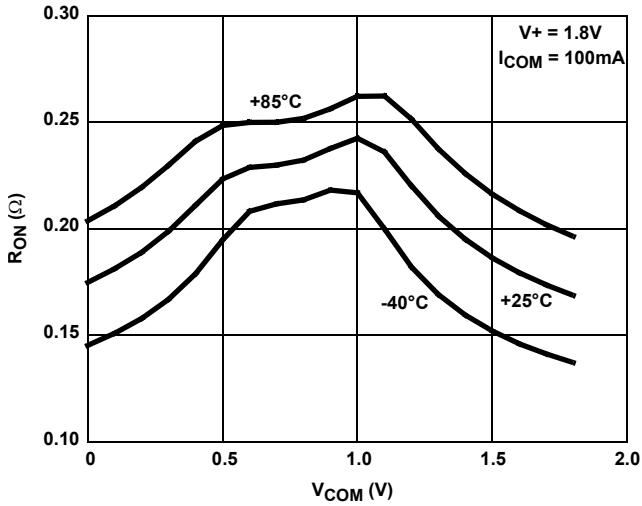

FIGURE 10. ON RESISTANCE vs SWITCH VOLTAGE

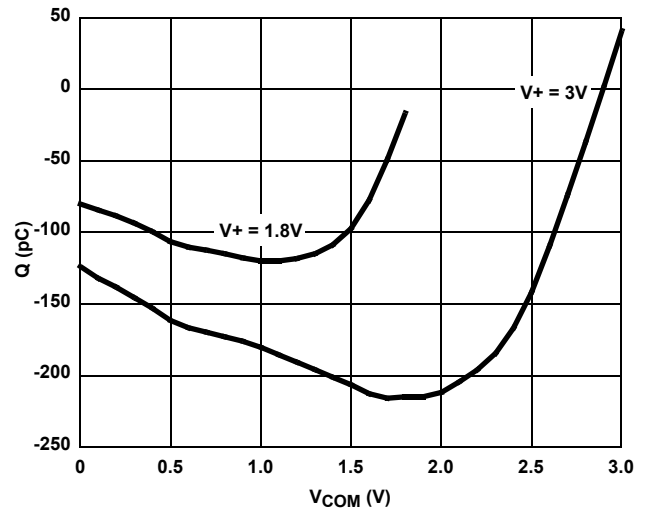

FIGURE 11. CHARGE INJECTION vs SWITCH VOLTAGE

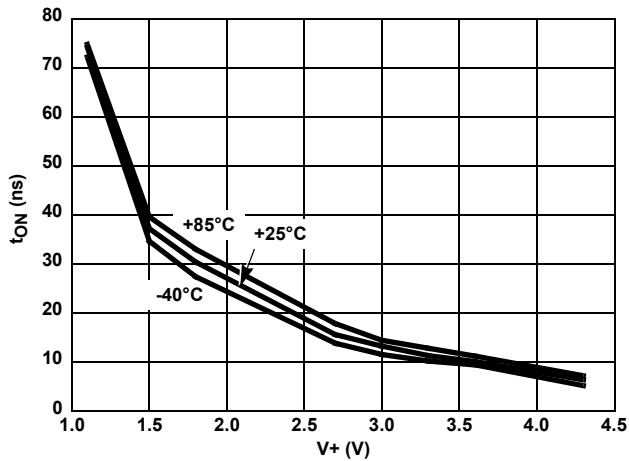

FIGURE 12. TURN-ON TIME vs SUPPLY VOLTAGE

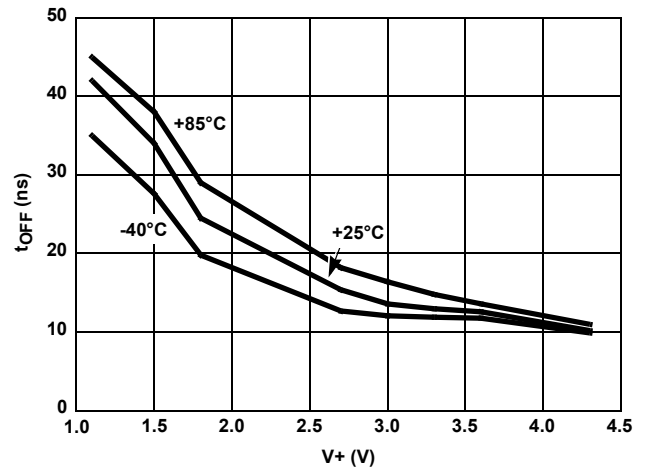

FIGURE 13. TURN-OFF TIME vs SUPPLY VOLTAGE



**Typical Performance Curves**  $T_A = +25^\circ\text{C}$ , Unless Otherwise Specified (Continued)

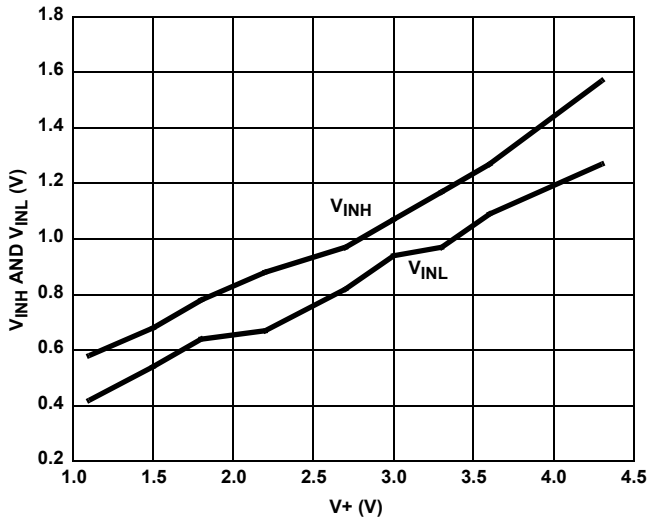

FIGURE 14. DIGITAL SWITCHING POINT vs SUPPLY VOLTAGE

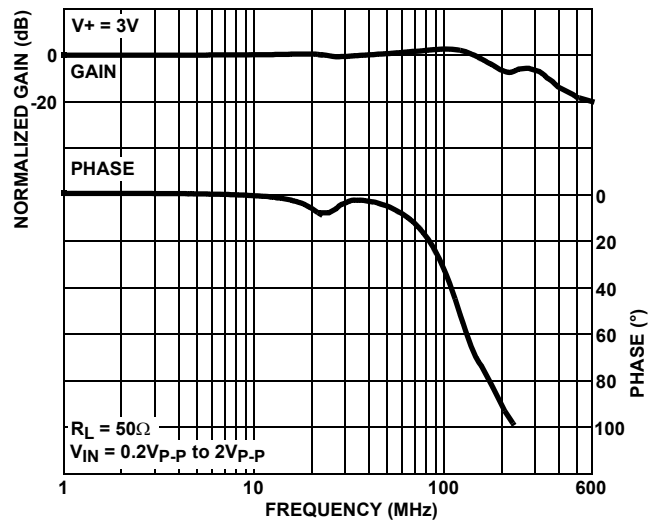

FIGURE 15. FREQUENCY RESPONSE

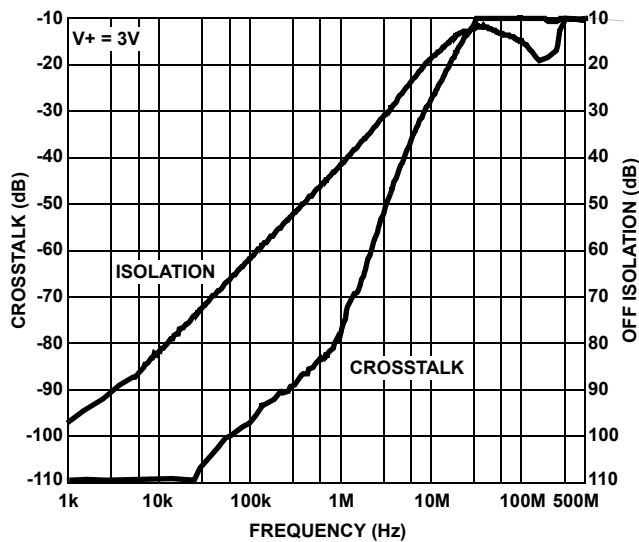

FIGURE 16. CROSSTALK AND OFF ISOLATION

**Die Characteristics**

SUBSTRATE POTENTIAL (POWERED UP):

GND

TRANSISTOR COUNT:

114

PROCESS:

Submicron CMOS

Thin Dual Flat No-Lead Plastic Package (TDFN)

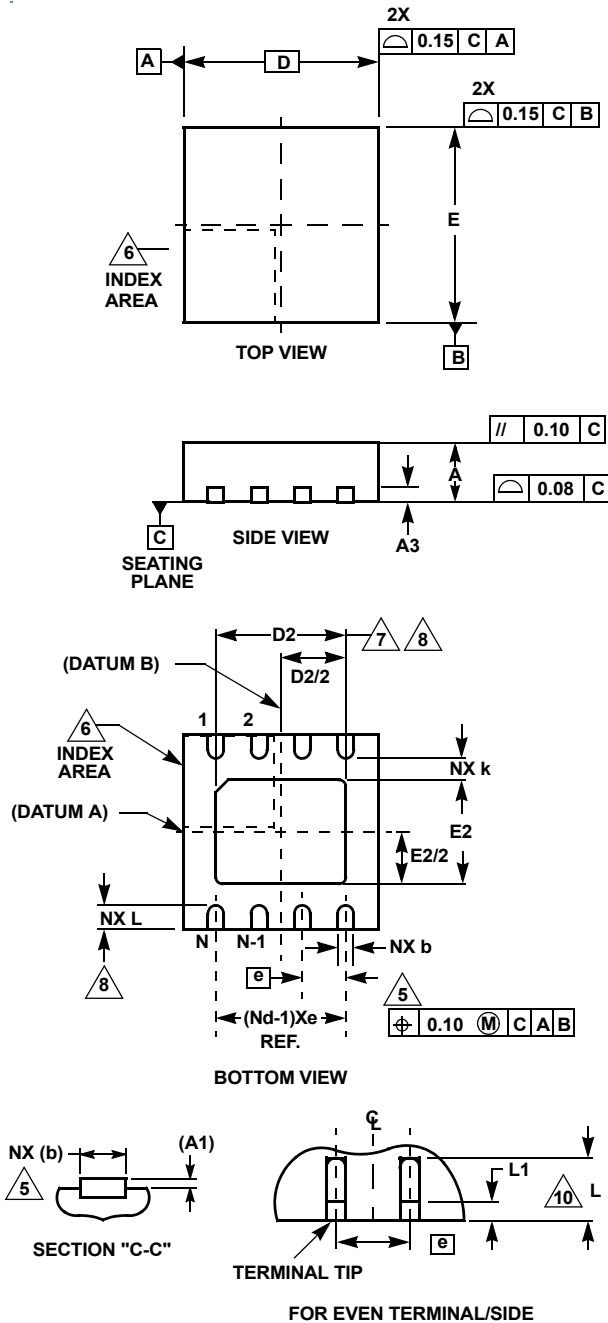

L8.3x3A

8 LEAD THIN DUAL FLAT NO-LEAD PLASTIC PACKAGE

SYMBOL	MILLIMETERS			NOTES
	MIN	NOMINAL	MAX	
A	0.70	0.75	0.80	-
A1	-	0.02	0.05	-
A3	0.20 REF			-
b	0.25	0.30	0.35	5, 8
D	3.00 BSC			-
D2	2.20	2.30	2.40	7, 8, 9
E	3.00 BSC			-
E2	1.40	1.50	1.60	7, 8, 9
e	0.65 BSC			-
k	0.25	-	-	-
L	0.20	0.30	0.40	8
N	8			2
Nd	4			3

Rev. 3 11/04

NOTES:

1. Dimensioning and tolerancing conform to ASME Y14.5-1994.
2. N is the number of terminals.
3. Nd refers to the number of terminals on D.
4. All dimensions are in millimeters. Angles are in degrees.
5. Dimension b applies to the metallized terminal and is measured between 0.15mm and 0.30mm from the terminal tip.
6. The configuration of the pin #1 identifier is optional, but must be located within the zone indicated. The pin #1 identifier may be either a mold or mark feature.
7. Dimensions D2 and E2 are for the exposed pads which provide improved electrical and thermal performance.
8. Nominal dimensions are provided to assist with PCB Land Pattern Design efforts, see Intersil Technical Brief TB389.
9. Compliant to JEDEC MO-WEEC-2 except for the "L" min dimension.

Mini Small Outline Plastic Packages (MSOP)

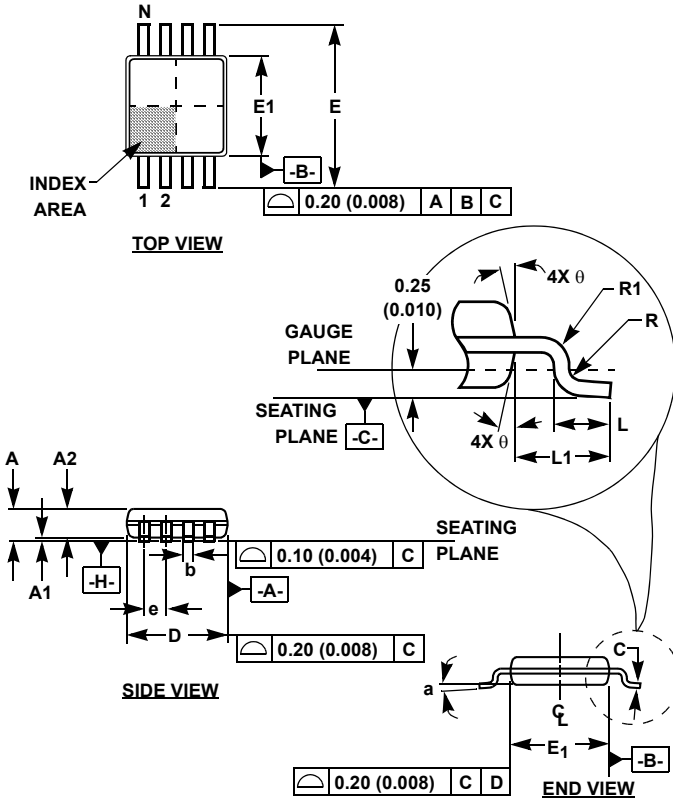

M8.118 (JEDEC MO-187AA)  
8 LEAD MINI SMALL OUTLINE PLASTIC PACKAGE

SYMBOL	INCHES		MILLIMETERS		NOTES
	MIN	MAX	MIN	MAX	
A	0.037	0.043	0.94	1.10	-
A1	0.002	0.006	0.05	0.15	-
A2	0.030	0.037	0.75	0.95	-
b	0.010	0.014	0.25	0.36	9
c	0.004	0.008	0.09	0.20	-
D	0.116	0.120	2.95	3.05	3
E1	0.116	0.120	2.95	3.05	4
e	0.026 BSC		0.65 BSC		-
E	0.187	0.199	4.75	5.05	-
L	0.016	0.028	0.40	0.70	6
L1	0.037 REF		0.95 REF		-
N	8		8		7
R	0.003	-	0.07	-	-
R1	0.003	-	0.07	-	-
θ	5°	15°	5°	15°	-
α	0°	6°	0°	6°	-

Rev. 2 01/03

NOTES:

- These package dimensions are within allowable dimensions of JEDEC MO-187BA.
- Dimensioning and tolerancing per ANSI Y14.5M-1994.
- Dimension "D" does not include mold flash, protrusions or gate burrs and are measured at Datum Plane. Mold flash, protrusion and gate burrs shall not exceed 0.15mm (0.006 inch) per side.
- Dimension "E1" does not include interlead flash or protrusions and are measured at Datum Plane. [-H-] Interlead flash and protrusions shall not exceed 0.15mm (0.006 inch) per side.
- Formed leads shall be planar with respect to one another within 0.10mm (0.004) at seating Plane.
- "L" is the length of terminal for soldering to a substrate.
- "N" is the number of terminal positions.
- Terminal numbers are shown for reference only.
- Dimension "b" does not include dambar protrusion. Allowable dambar protrusion shall be 0.08mm (0.003 inch) total in excess of "b" dimension at maximum material condition. Minimum space between protrusion and adjacent lead is 0.07mm (0.0027 inch).
- Datums [-A-] and [-B-] to be determined at Datum plane [-H-].
- Controlling dimension: MILLIMETER. Converted inch dimensions are for reference only.

All Intersil U.S. products are manufactured, assembled and tested utilizing ISO9001 quality systems.  
Intersil Corporation's quality certifications can be viewed at [www.intersil.com/design/quality](http://www.intersil.com/design/quality)

*Intersil products are sold by description only. Intersil Corporation reserves the right to make changes in circuit design, software and/or specifications at any time without notice. Accordingly, the reader is cautioned to verify that data sheets are current before placing orders. Information furnished by Intersil is believed to be accurate and reliable. However, no responsibility is assumed by Intersil or its subsidiaries for its use; nor for any infringements of patents or other rights of third parties which may result from its use. No license is granted by implication or otherwise under any patent or patent rights of Intersil or its subsidiaries.*

For information regarding Intersil Corporation and its products, see [www.intersil.com](http://www.intersil.com)