



## Multilayer Diplexer

For 698-960MHz / 1570-2690MHz

DPX Series 1.6x0.8mm [EIA 0603] TYPE

P/N: **DPX162690DT-8058A1**

## DPX162690DT-8058A1

### ■ SHAPES AND DIMENSIONS

[Top View]

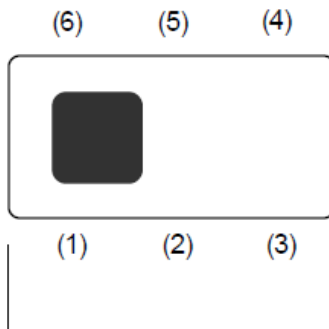

[Bottom View]

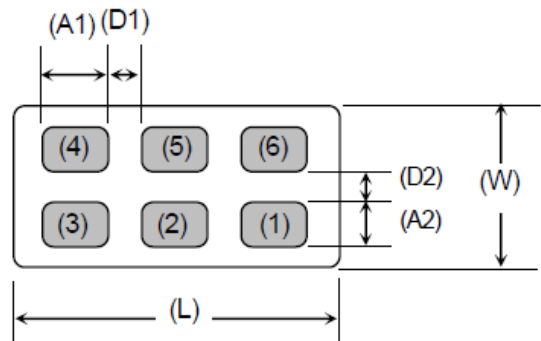

[Side View]



Dimensions (mm)

L	W	T	A1	D1	A2	D2
1.60	0.80	0.80	0.35	0.22	####	0.22
+/-0.10	+/-0.15	Max	+/-0.05	+/-0.05	+/-0.05	+/-0.05

Terminal functions

(1)	GND
(2)	Common Port
(3)	GND

(4)	High-Band Port
(5)	GND
(6)	Low-Band Port

### ■ TERMINATION FINISH

Material
Au plate

## DPX162690DT-8058A1

### ■ ELECTRICAL CHARACTERISTICS

( Measurement )

#### Low-Band

Parameter	Frequency (MHz)	TDK Spec		
		Min.	Typ.	Max.
Insertion Loss (dB)	698 to 960	-	0.58	0.73
Insertion Loss (dB) ( -40 to +85 °C )	698 to 960	-	0.65	0.83
Return Loss@Common (dB)	698 to 960	12	19	-
Return Loss@Low-Band (dB)	698 to 960	12	19	-
Attenuation (dB)	1570 to 2690	25	28	-
Characteristic Impedance (ohm)		50 (Nominal)		

Ta = +25+/-5°C

#### High-Band

Parameter	Frequency (MHz)	TDK Spec		
		Min.	Typ.	Max.
Insertion Loss (dB)	1570 to 2690	-	0.47	0.70
Insertion Loss (dB) ( -40 to +85 °C )	1570 to 2690	-	0.52	0.78
Return Loss@Common (dB)	1570 to 2690	12	16	-
Return Loss@High-Band (dB)	1570 to 2690	12	17	-
Attenuation (dB)	698 to 814	20	23	-
	814 to 905	23	25	-
	905 to 960	20	24	-
	5150 to 5850	12	15	-
Characteristic Impedance (ohm)		50 (Nominal)		

Ta = +25+/-5°C

## DPX162690DT-8058A1

### ■ ELECTRICAL CHARACTERISTICS

( Measurement )

#### Isolation

Parameter	Frequency (MHz)	TDK Spec		
		Min.	Typ.	Max.
Isolation (dB)	698 to 814	20	23	-
	814 to 905	23	26	-
	905 to 960	20	29	-
	1570 to 2690	25	29	-

Ta = +25+/-5°C

### ■ MAXIMUM RATINGS

Parameter		TDK Spec	Conditions
Operating temperature (°C)		-40 to +85 °C	
Storage temperature (°C)		-40 to +85 °C	
Power Handling (W) <sup>*1</sup>	Frequency (MHz)		
	Low-Band	698 to 960	4 CW Duty 50%
	High-Band	1570 to 2690	3 CW Duty 50%
Human Body Model : HBM	@Each Port (V)	+/-1000	100pF / 1500ohm
Machine Model : MM	@Each Port (V)	+/-150	200pF / 0ohm
Charged Device Model : CDM	@Each Port (V)	+/-500	Humidity : 60%RH max

\*1 : Refer to 3GPP TS 38.101-1 V15.2.0

# DPX162690DT-8058A1

## FREQUENCY CHARACTERISTICS

Low-Band Port

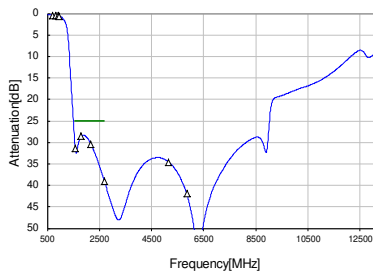

Insertion Loss	
698 MHz	0.39 dB
814 MHz	0.43 dB
905 MHz	0.49 dB
960 MHz	0.58 dB

Attenuation	
1570 MHz	31.48 dB
1805 MHz	28.49 dB
2170 MHz	30.39 dB
2690 MHz	39.06 dB
5150 MHz	34.55 dB
6850 MHz	41.95 dB

High-Band Port

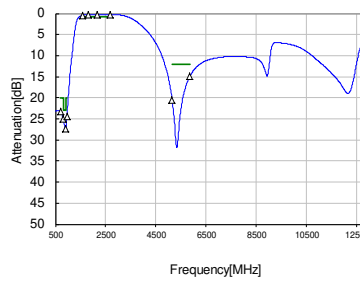

Insertion Loss	
1570 MHz	0.47 dB
1805 MHz	0.26 dB
2170 MHz	0.26 dB
2690 MHz	0.25 dB

Attenuation	
698 MHz	23.27 dB
814 MHz	25.03 dB
905 MHz	27.27 dB
960 MHz	24.32 dB
5150 MHz	20.56 dB
6850 MHz	14.96 dB

Low-Band Port

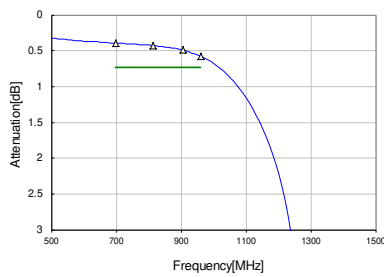

Insertion Loss	
698 MHz	0.39 dB
814 MHz	0.43 dB
905 MHz	0.49 dB
960 MHz	0.58 dB

High-Band Port

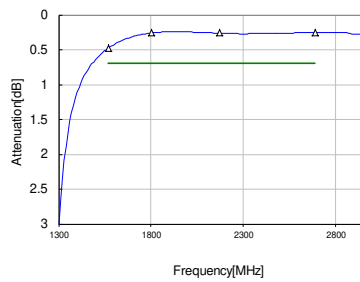

Insertion Loss	
1570 MHz	0.47 dB
1805 MHz	0.26 dB
2170 MHz	0.26 dB
2690 MHz	0.25 dB

Common Port Return Loss

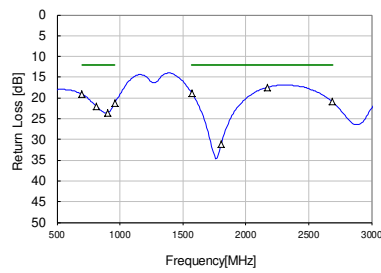

698 MHz	19.07 dB
814 MHz	21.97 dB
905 MHz	23.67 dB
960 MHz	21.20 dB

1570 MHz	18.85 dB
1805 MHz	31.07 dB
2170 MHz	17.49 dB
2690 MHz	20.93 dB

Isolation

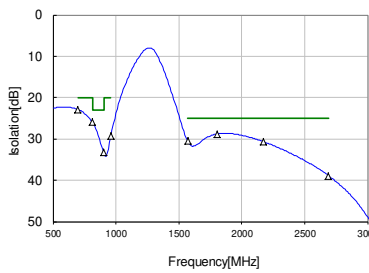

698 MHz	22.9 dB
814 MHz	25.9 dB
905 MHz	33.2 dB
960 MHz	29.3 dB

1570 MHz	30.5 dB
1805 MHz	28.8 dB
2170 MHz	30.6 dB
2690 MHz	38.9 dB

Low-Band Port Return Loss

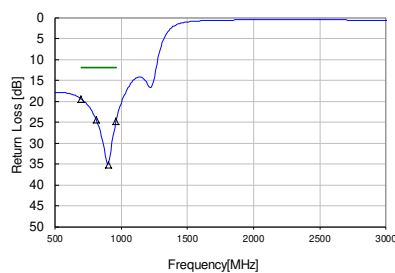

698 MHz	19.45 dB
814 MHz	24.32 dB
905 MHz	35.12 dB
960 MHz	24.81 dB

High-Port Return Loss

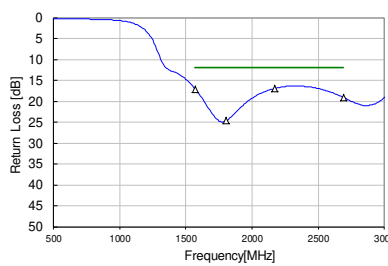

1570 MHz	17.14 dB
1805 MHz	24.65 dB
2170 MHz	16.99 dB
2690 MHz	19.08 dB

## DPX162690DT-8058A1

### RECOMMENDED LAND PATTERN

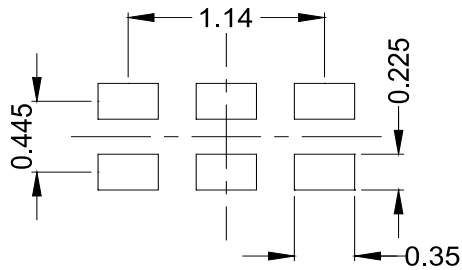

unit : mm

### EVALUATION BOARD

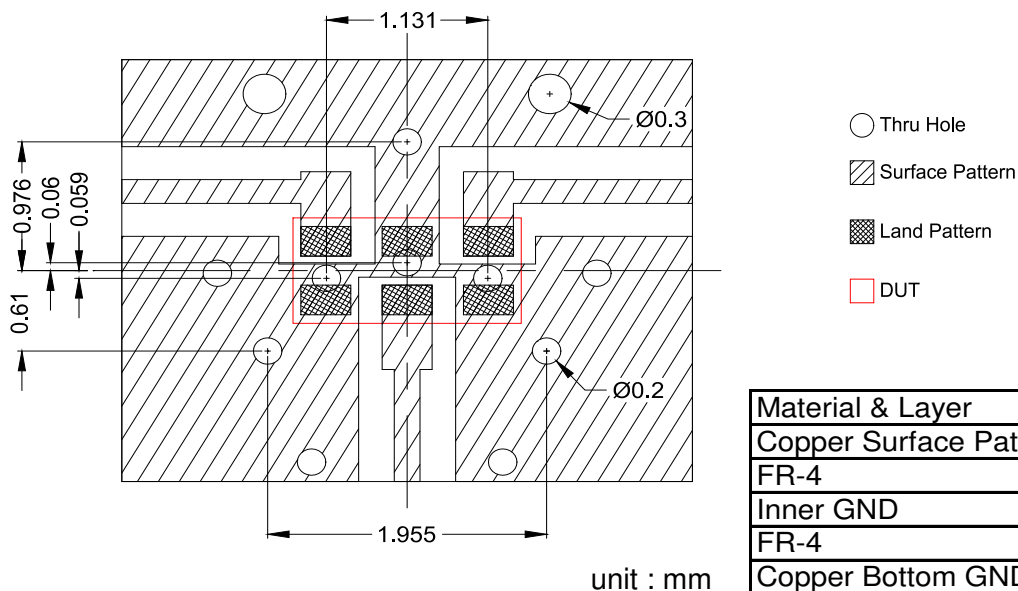

unit : mm

\* Line width should be designed to match 50 ohm characteristic impedance depending on PCB material and thickness.

\*\* The position of the through hole which have possibility of influence to the performance are indicated by dimension line.

### ENVIRONMENT INFORMATION

RoHS Statement

RoHS Compliance

All specifications are subject to change without notice.

Before using these products, be sure to request the delivery specifications.

## DPX162690DT-8058A1

### RECOMMENDED REFLOW PROFILE

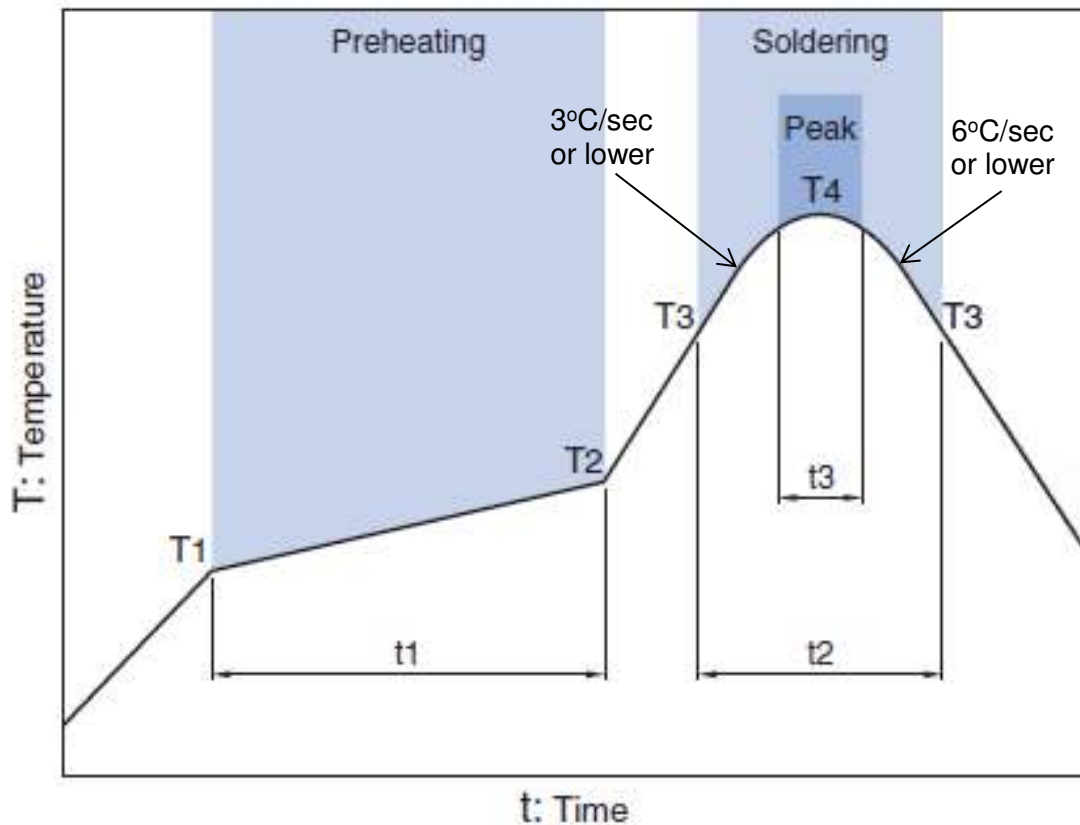

Preheating			Soldering			
Temp.		Time	Critical zone (T3 to T4)		Peak	
T1	T2	t1	T3	t2	T4	t3 *
150°C	200°C	60 to 120sec	217°C	60 to 120sec	240 to 260°C	30 sec Max

\* t3 : Time within 5°C of actual peak temperature

The maximum number of reflow is 3.

Note: Lead free solder is recommended.  
Recommended solder is Sn-3.0Ag-0.5Cu. (M705 by Senju Metal Industry)

### GENERAL TECHNICAL INFORMATION

[https://product.tdk.com/en/system/files?file=dam/doc/product/rf/rf/diplexer/general\\_tech\\_info/rf\\_general-technical-info\\_02\\_en.pdf](https://product.tdk.com/en/system/files?file=dam/doc/product/rf/rf/diplexer/general_tech_info/rf_general-technical-info_02_en.pdf)

All specifications are subject to change without notice.  
Before using these products, be sure to request the delivery specifications.

**DPX162690DT-8058A1****PACKAGING STYLE**

Reel Dimensions

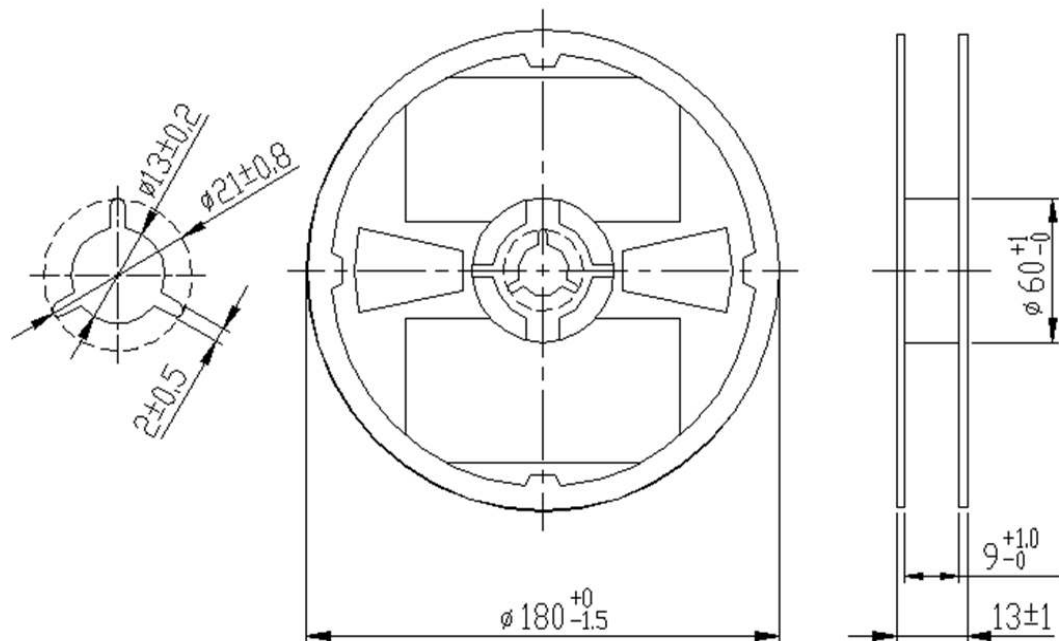

Dimensions in mm

Carrier Tape

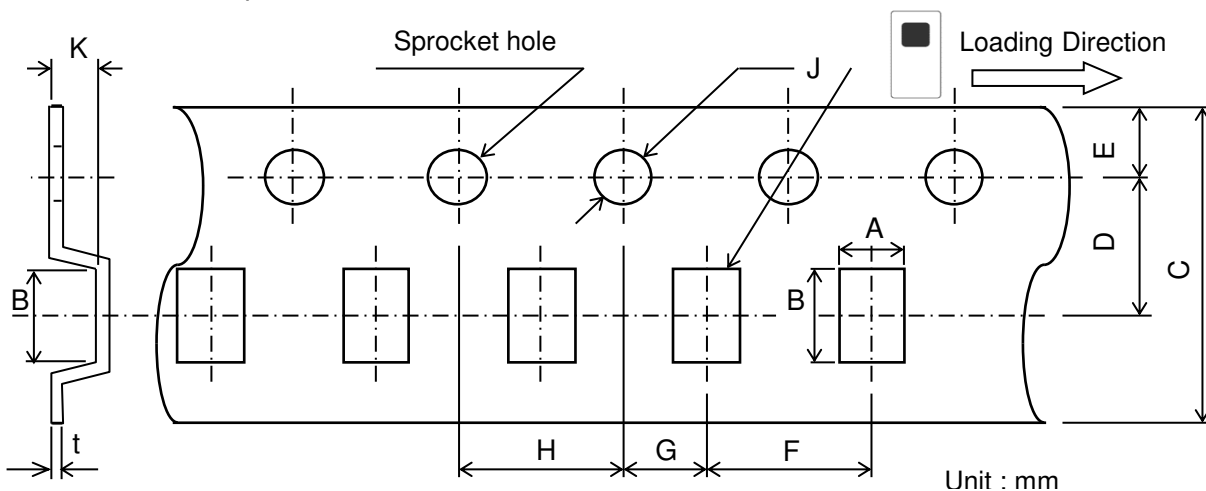

Dimensions (mm)

A	B	C	D	E	F	G	H	J	K	t
0.97	1.8	8.0	3.5	1.75	4.0	2.0	4.0	1.5	1.0	0.25
+/-0.05	+/-0.05	+0.3/-0.1	+/-0.05	+/-0.1	+/-0.1	+/-0.05	+/-0.1	+0.1/-0	Max	+/-0.05

STANDARD PACKAGE QUANTITY ( pieces/reel )
4,000

All specifications are subject to change without notice.  
Before using these products, be sure to request the delivery specifications.



## REMINDERS FOR USING THESE PRODUCTS

Before using these products, be sure to request the delivery specifications.

### SAFETY REMINDERS

Please pay sufficient attention to the warnings for safe designing when using these products.

#### REMINDERS

The products listed on this catalog are intended for use in general electronic equipment (AV equipment, telecommunications equipment, home appliances, amusement equipment, computer equipment, personal equipment, office equipment, measurement equipment, industrial robots) under a normal operation and use condition.

The products are not designed or warranted to meet the requirements of the applications listed below, whose performance and/or quality require a more stringent level of safety or reliability, or whose failure, malfunction or trouble could cause serious damage to society, person or property.

Please understand that we are not responsible for any damage or liability caused by use of the products in any of the applications below or for any other use exceeding the range or conditions set forth in this catalog.

- |   |  |
|---|--|
| (1) Aerospace/Aviation equipment                                  | (8) Public information-processing equipment                                  |
| (2) Transportation equipment (cars, electric trains, ships, etc.) | (9) Military equipment   |
| (3) Medical equipment   | (10) Electric heating apparatus, burning equipment                           |
| (4) Power-generation control equipment                            | (11) Disaster prevention/crime prevention equipment                          |
| (5) Atomic energy-related equipment                               | (12) Safety equipment  |
| (6) Seabed equipment  | (13) Other applications that are not considered general-purpose applications |
| (7) Transportation control equipment                              |  |

When using this product in general-purpose applications, you are kindly requested to take into consideration securing protection circuit/equipment or providing backup circuits, etc., to ensure higher safety.