

This document is the property of Amphenol Corporation and is delivered on the express condition that is not to be disclosed, reproduced or used, in whole or in part, for manufacture or sale by anyone other than Amphenol Corporation without its prior consent, and that no right is granted to disclose or to use any information in this document.

The marking on this product doesn't contain environmental hazardous materials per Material Specification 55-00259 for Sony GP compliant or per directive 2011/65/EU for RoHS compliant.



ORIGINAL



REVISIONS				
SYM	ECN No.	DESCRIPTION	DATE	APPROVED
A	NE-17046	RELEASE TO PRODUCTION	03/15/2017	Arron Lin
B	NE-17176	UPDATE PACKING	08/02/2017	Arron Lin

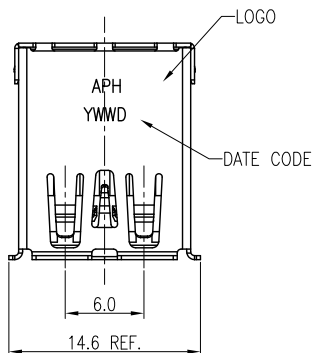

P/N: GSB311JXX0H3HR

CONTACT FINISH: COLOR OPTION / SHELL PLATING OPTION
 1: FLASH GOLD 5: BLUE (300C) /BLACK NICKEL
 2: 15u" GOLD 6: BLACK /BLACK NICKEL
 3: 30u" GOLD 7: BLUE (300C) /NICKEL
 8: BLACK /NICKEL

NOTES:

- MATERIAL:
 HOUSING: THERMOPLASTIC PA10T(HF) , UL94V-0, COLOR: OPTION.
 COVER: THERMOPLASTIC PA10T(HF) , UL94V-0, COLOR: OPTION.
 USB 3.0 TERMINAL(5~9PIN): BRASS.
 USB 2.0 TERMINAL(1~4PIN): PHOSPHOR BRONZE,
 SHELL: STEEL
- FINISH:
 TERMINAL:
 CONTACT AREA: SELECTIVE GOLD PLATING ;
 SOLDERING AREA: MATTE TIN PLATING 100 μ" THICKNESS MIN.;
 UNDER PLATING: NICKEL PLATING 50 μ" THICKNESS MIN.OVERALL.
 SHELL:
 BLACK NICKEL OR NICKEL PLATING 50 μ" THICKNESS MIN.OVERALL.
- THIS PRODUCT DOESN'T CONTAIN ENVIRONMENTAL HAZARDOUS PER DIRECTIVE 2011/65/EU FOR RoHS COMPLIANT.
- PRODUCT SPECIFICATION REFER TO : PS-7425.

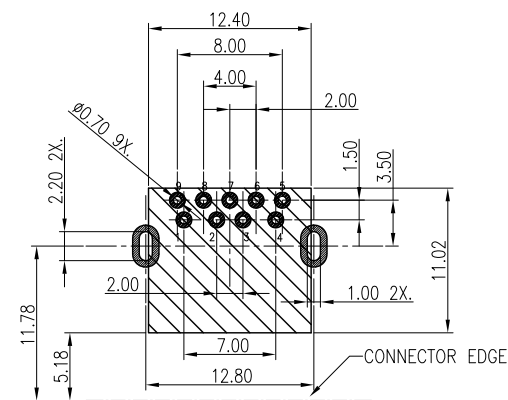
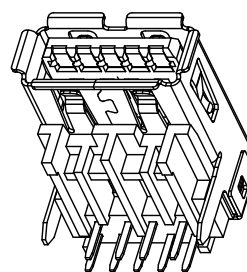
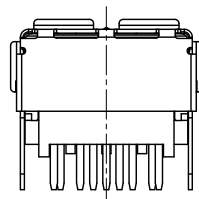
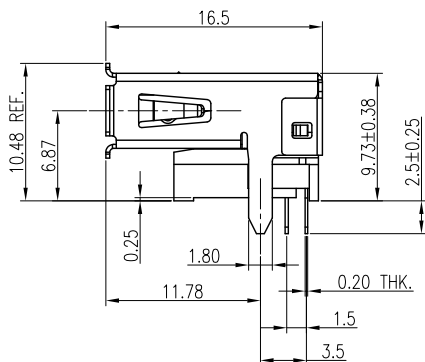
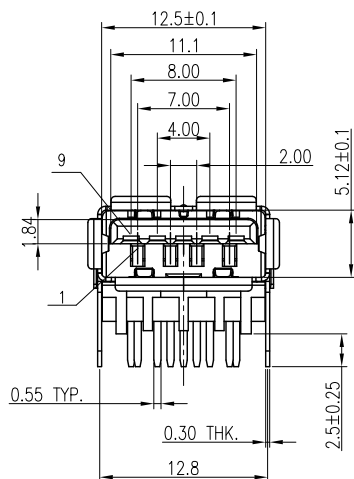

RECOMMENDED PCB LAYOUT
 TOP VIEW, THK=1.6MM
 KEEP OUT AREA.

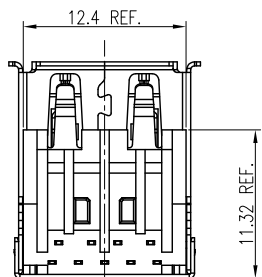

Pin Number	Signal Name
1	VBUS
2	D-
3	D+
4	GND
5	SSRX-
6	SSRX+
7	GND_DRAIN
8	SSTX-
9	SSTX+
Shell	Shield

TOLERANCE	APPROVALS	DATE	TITLE	UNIT	SIZE	PART No.
X. ±0.30	DRAWN Debby hung	08/02/2017	USB 3.0 TYPE A CONN. HIGH-RISE R/A DIP TYPE (CH=6.87H)	mm	A3	GSB311JXX0H3HR
X.X ±0.20	CHECKED Sandy Wu	08/02/2017				
X.XX ±0.10	APPROVED Arron Lin	08/02/2017				
X.XXX						
ANGULAR ±1°	DWG TYPE CUST DWG	PROJECT CODE OTHER		SCALE NA	SHEET 1 OF 2	DWG No. GSB311JXX0H3HR
UNLESS OTHERWISE SPECIFIED						REV. B

Amphenol®
 Amphenol Corporation
 Amphenol Taiwan Corporation

This document is the property of Amphenol Corporation and is delivered on the express condition that is not to be disclosed, reproduced or used, in whole or in part, for manufacture or sale by anyone other than Amphenol Corporation without its prior consent, and that no right is granted to disclose or to use any information in this document.
 The marking on this product doesn't contain environmental hazardous materials per Material Specification 55-00259 for Sony GP compliant or per directive 2011/65/EU for RoHS compliant.



ORIGINAL



REVISIONS				
SYM	ECN No.	DESCRIPTION	DATE	APPROVED
A	NE-17046	RELEASE TO PRODUCTION	03/15/2017	Arron Lin
B	NE-17176	UPDATE PACKING	08/02/2017	Arron Lin

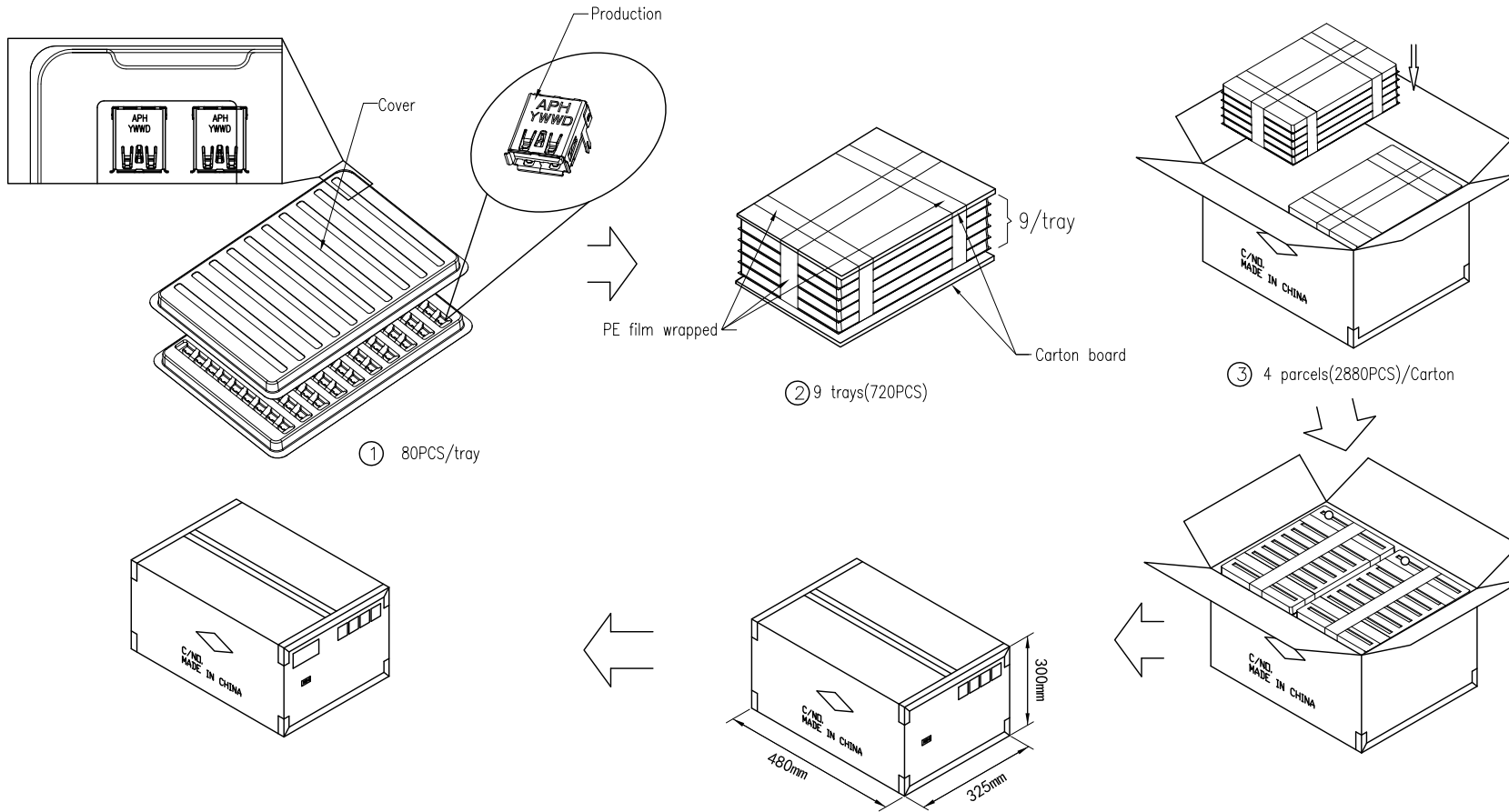

PACKAGING BY TRAY	10.4	8.1	80	36	2880	GSB311JXX0H3HR
	G/W KG	N/W KG	PCS/TRAY	TRAYS/BOX	QUANTITY (PCS)	PART NUMBER

TOLERANCE	APPROVALS	DATE	TITLE		PART No.	
X. ±0.30	DRAWN Debby Hung	08/02/2017	USB 3.0 TYPE A CONN. HIGH-RISE R/A DIP TYPE (CH=6.87H)		Amphenol® Amphenol Corporation Amphenol Taiwan Corporation	
X.X ±0.20	CHECKED Sandy Wu	08/02/2017				
X.XX ±0.10	APPROVED Arron Lin	08/02/2017				
ANGULAR ±1°	DWG TYPE CUST DWG	PROJECT CODE OTHER				
UNLESS OTHERWISE SPECIFIED			UNIT mm	SCALE NA	SIZE A3	SHEET 2 OF 2
					PART No. GSB311JXX0H3HR DWG No. GSB311JXX0H3HR REV. B	