

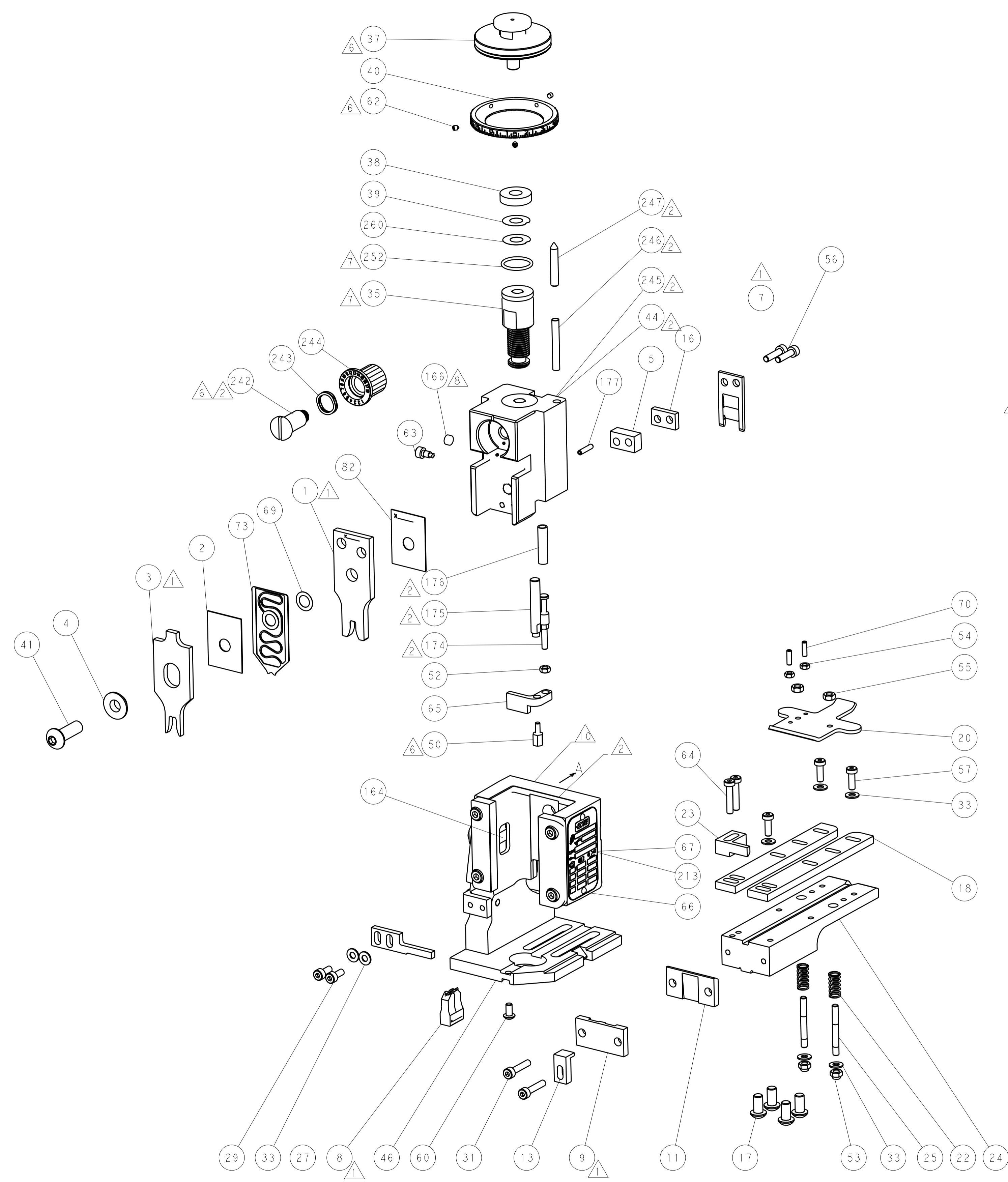

| LOC |    | DIST |     | REVISIONS   |      |     |      |
|-----|----|------|-----|-------------|------|-----|------|
| A   | 66 | P    | LYN | DESCRIPTION | DATE | DWN | APVD |
|     |    | -    |     | SEE SHEET 1 |      |     |      |

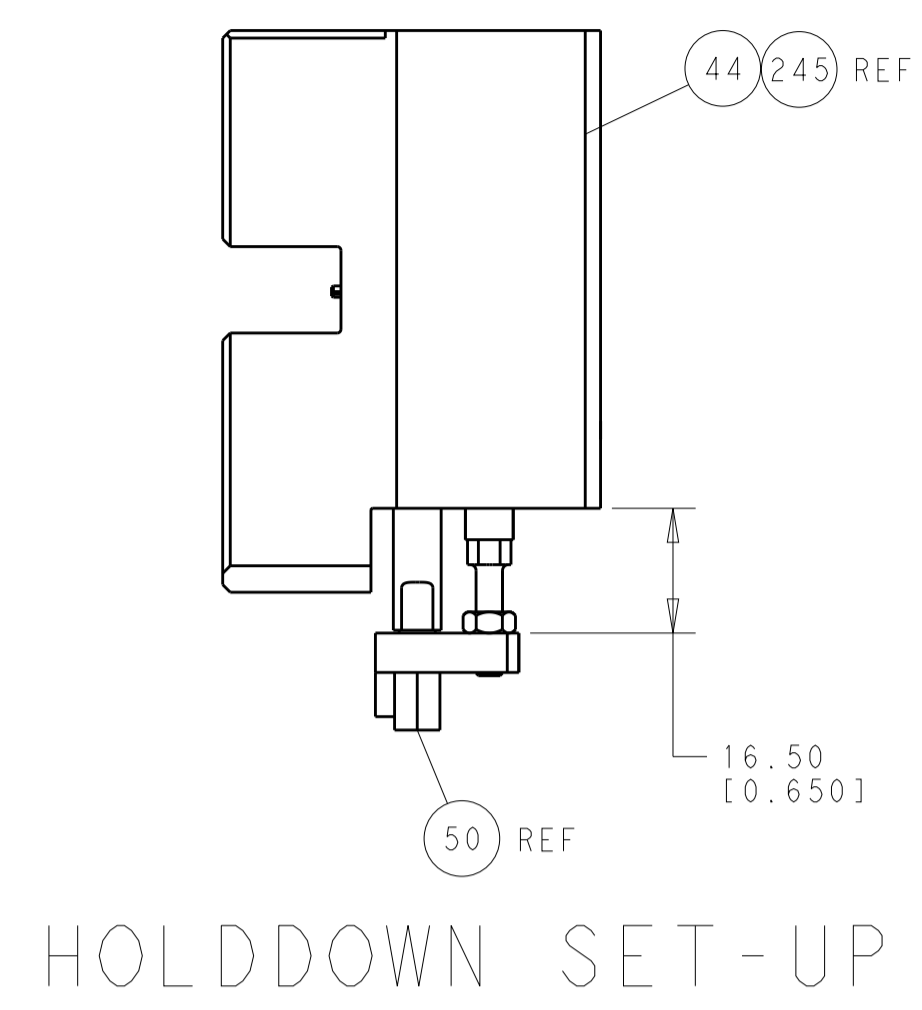

FEED TYPE

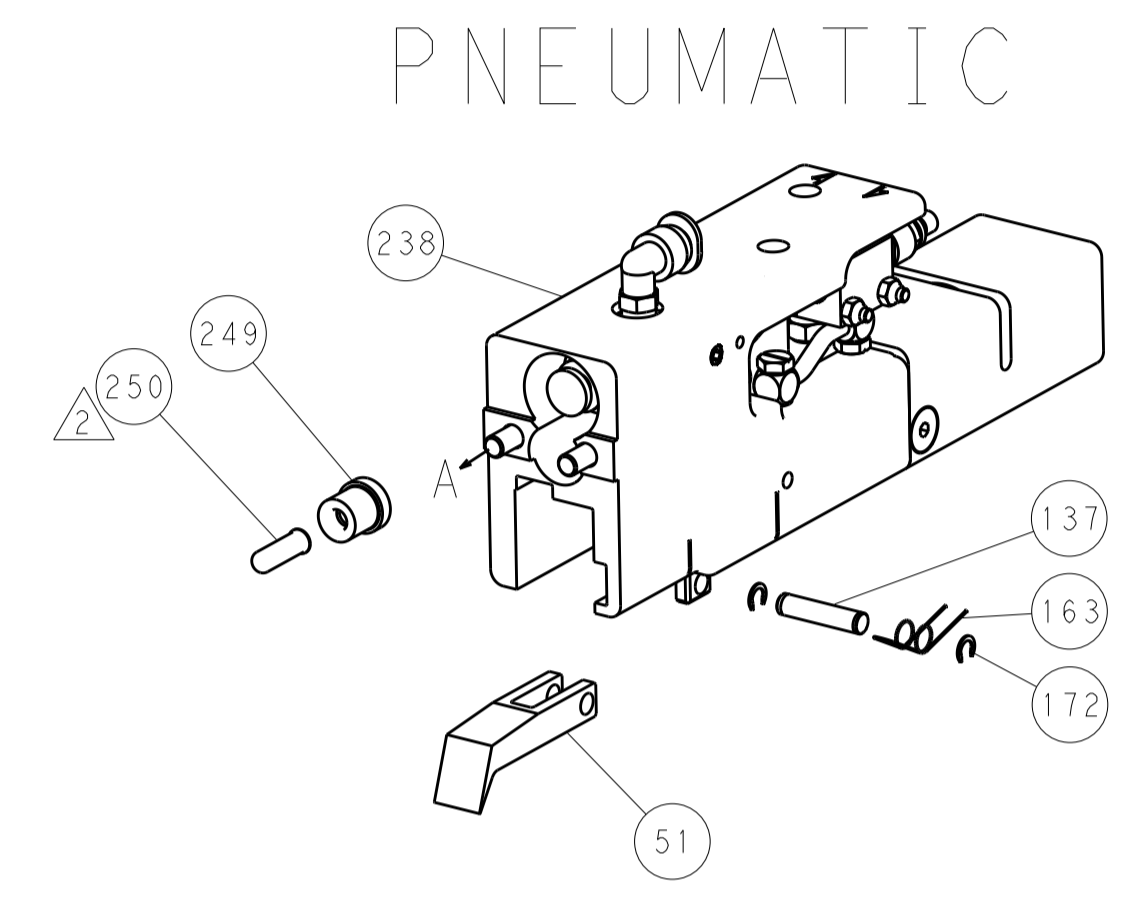

CAM POSITION

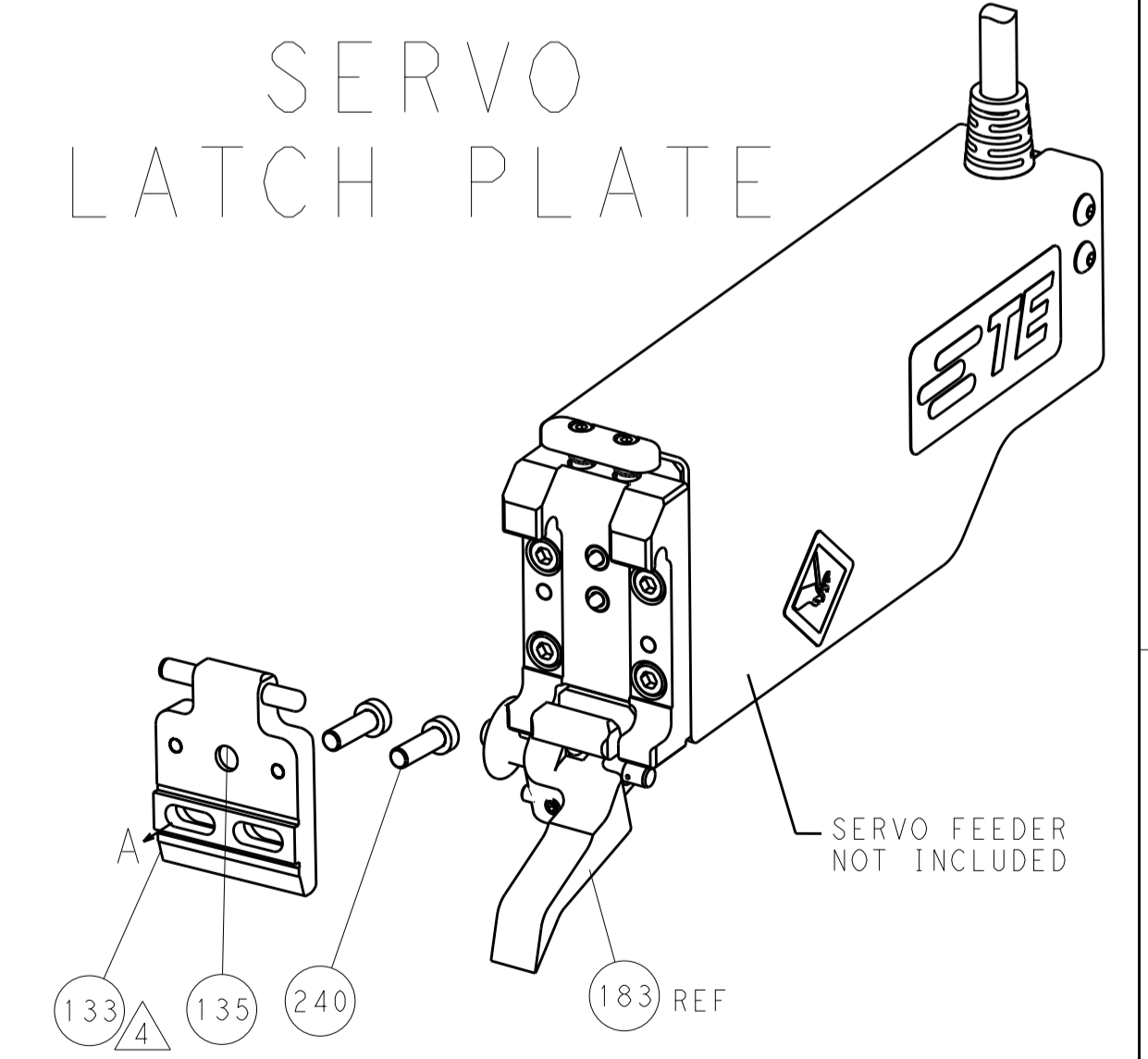
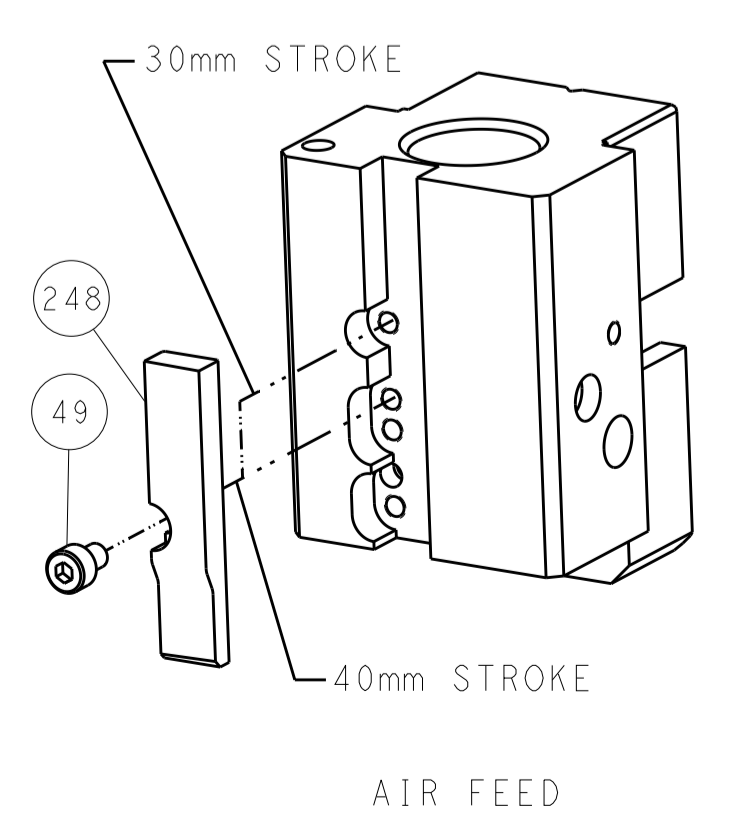

ATLANTIC VERSION  
 Shown on sheets 1 of 4 & 2 of 4  
 (Pacific version shown on sheets 3 of 4 & 4 of 4)

|             |              |  |             |                  |        |                 |   |
|-------------|--------------|--|-------------|------------------|--------|-----------------|---|
| DIMENSIONS: |              | TOLERANCES UNLESS OTHERWISE SPECIFIED: |             | DWN              |        | TE Connectivity |   |
| mm          | 0 PLC ±0.5   | 1 PLC ±0.5                             | 2 PLC ±0.13 | 3 PLC ±0.013     | Y. YIN | 26MAR2013       | TE Connectivity Harrisburg, PA 17105-3608 |
|             | 4 PLC ±0.001 | ANGLES ±0.001                          |             |                  | CHK    | G. BAILEY       |   |
| MATERIAL:   | FINISH:      | APVD                                   | NAME        | PRODUCT SPEC     | U. GUO | 26MAR2013       |   |
|             |              | WEIGHT                                 | SIZE        | APPLICATION SPEC |        |                 |   |
|             |              |  | A11         |                  |        |                 |   |
|             |              | Customer Accessible Production Drawing | SCALE       | 1:1              | SHEET  | 2               | OF 4                                      |
|             |              |  | REV         | A                |        |                 |   |



| LOC |    | DIST |     | REVISIONS   |      |     |      |
|-----|----|------|-----|-------------|------|-----|------|
| A   | 66 | P    | LTM | DESCRIPTION | DATE | OWN | APVD |
| -   | -  | -    | -   | SEE SHEET 1 | -    | -   | -    |

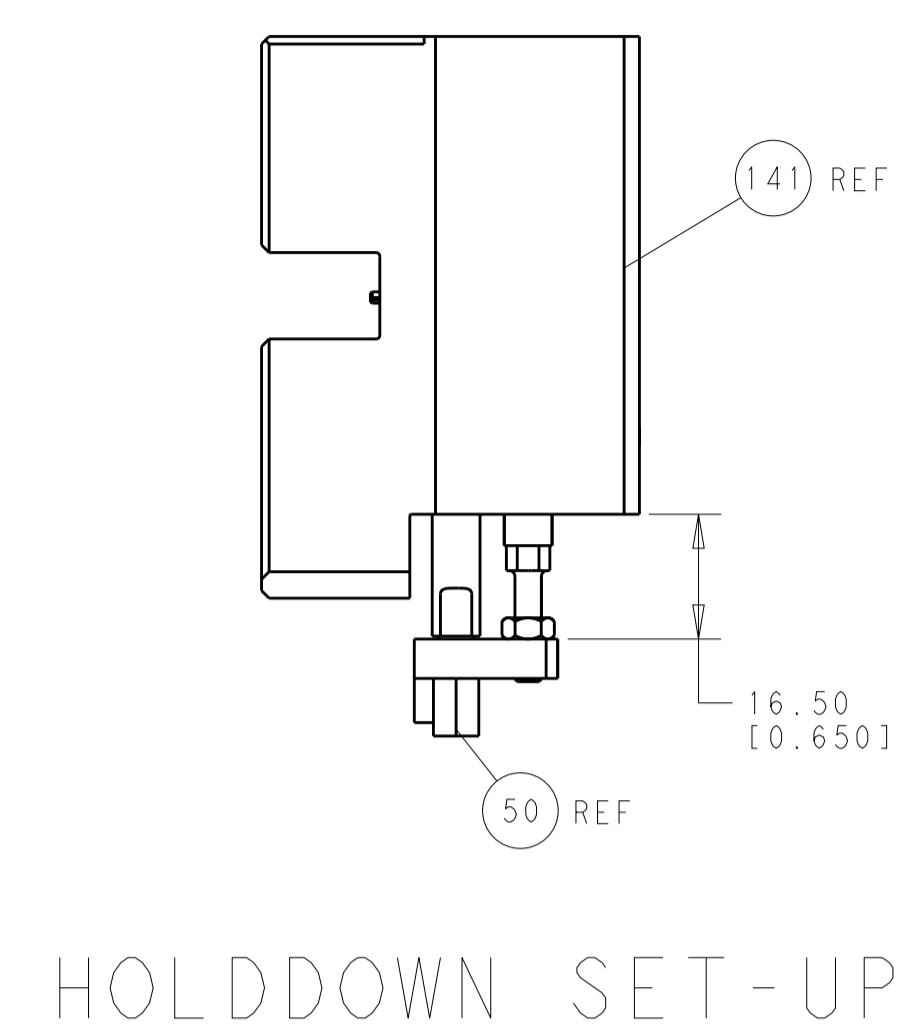

FEED TYPE

PNEUMATIC

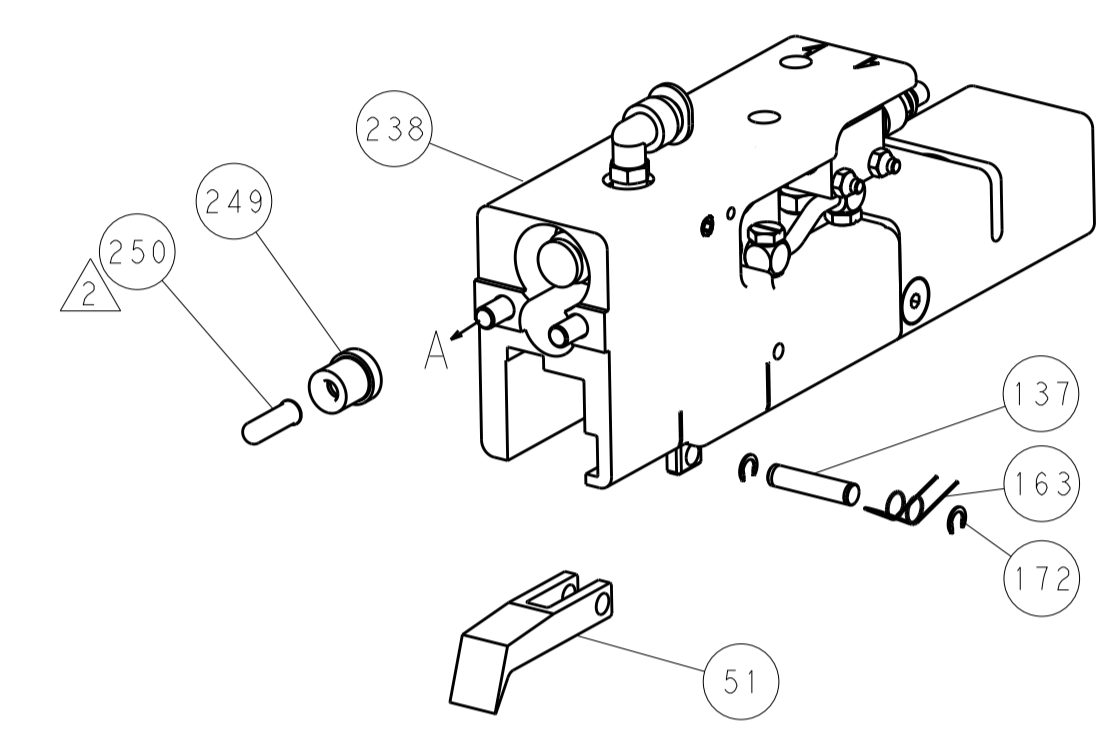

SERVO LATCH PLATE

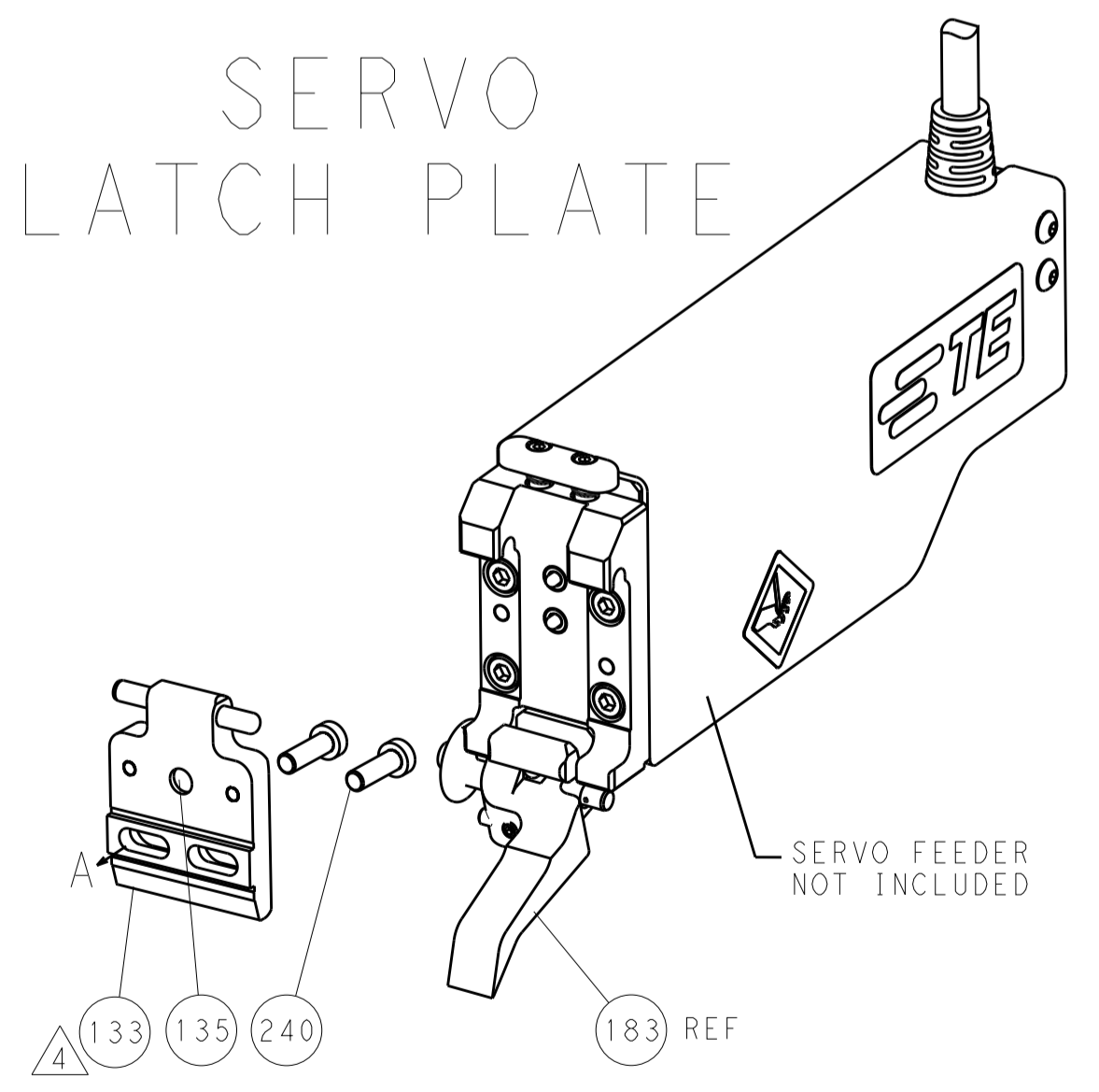

CAM POSITION

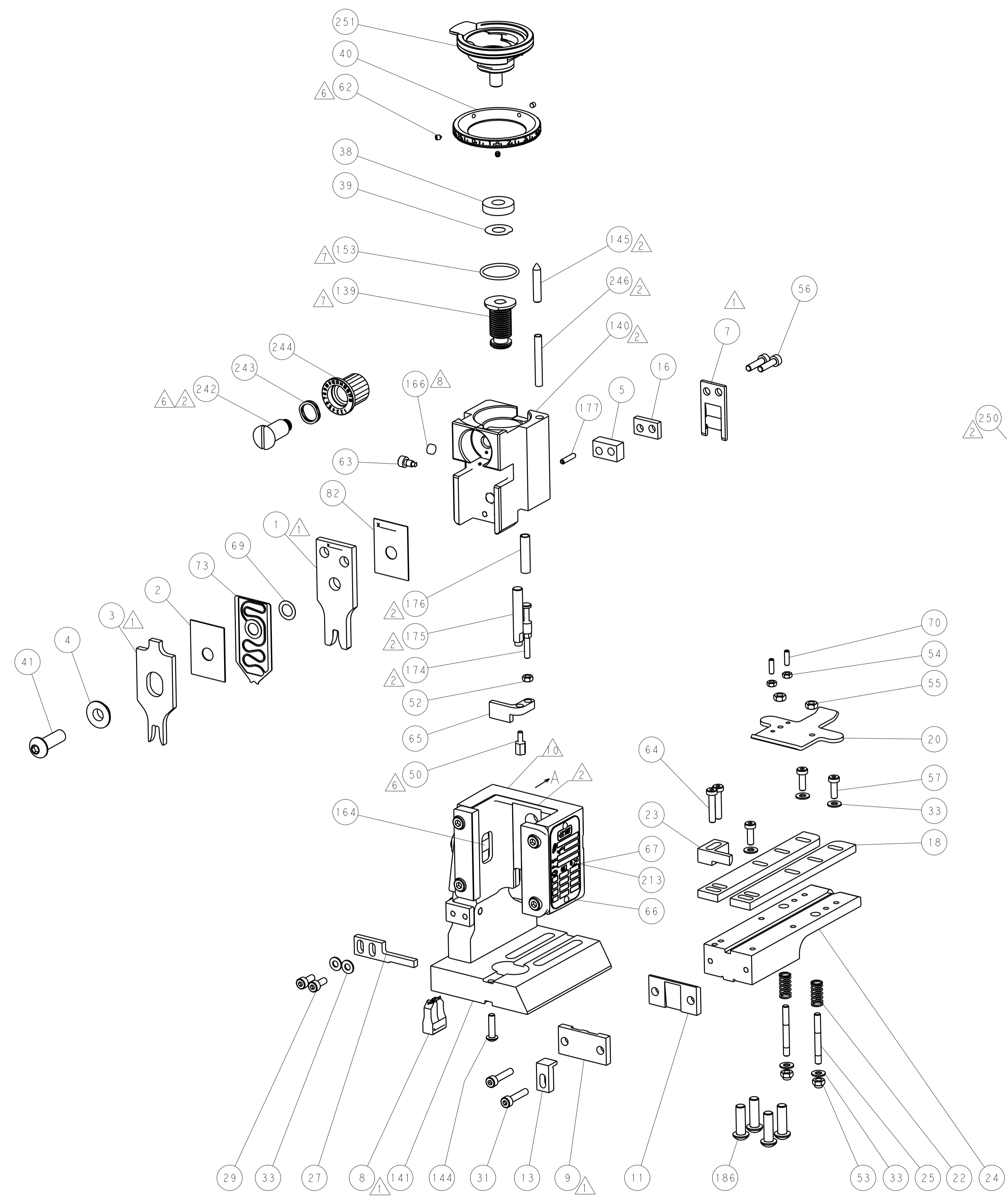
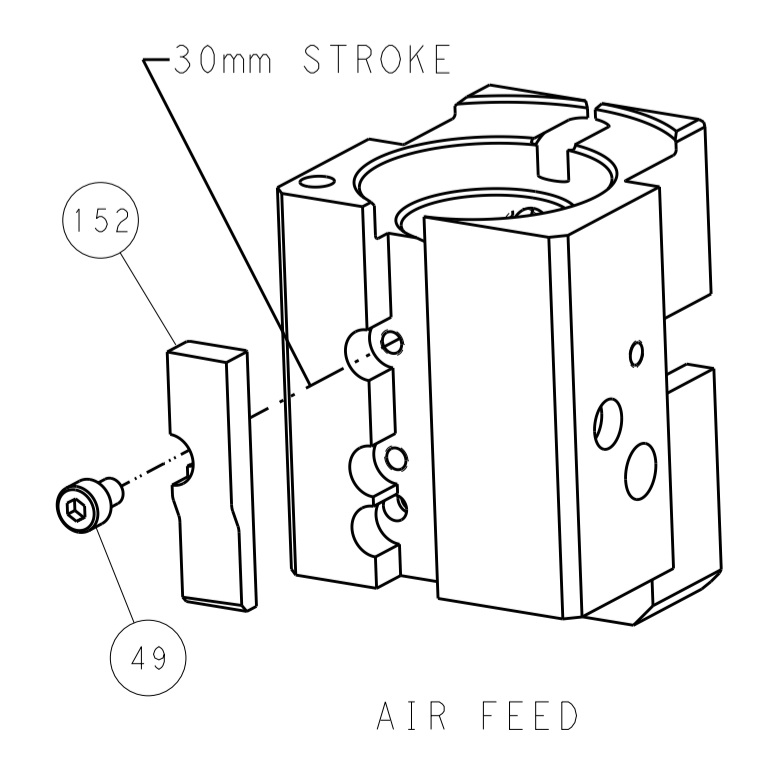

PACIFIC VERSION  
 Shown on sheets 3 of 4 & 4 of 4  
 (Atlantic version shown on sheets 1 of 4 & 2 of 4)

|  |  |   |  |  |  |   |  |
|--|--|---|--|--|--|---|--|
| DIMENSIONS:<br>mm<br>                  |  | TOLERANCES UNLESS OTHERWISE SPECIFIED:<br>0 PLC ±.5<br>1 PLC ±0.5<br>2 PLC ±0.13<br>3 PLC ±0.013<br>4 PLC ±0.0013<br>ANGLES ±.1 |  | DWN Y. YIN 26MAR2013<br>CHK G. BAILEY 26MAR2013<br>APVD H. GUO 26MAR2013 |  | NAME<br>Ocean End Feed Applicator                               |  |
| MATERIAL:                              |  | FINISH:   |  | WEIGHT:  |  | SIZE: CAGE CODE DRAWING NO. RESTRICTED TO<br>A1 00779 ©=2150320 |  |
| Customer Accessible Production Drawing |  |   |  | SCALE: 1:1   |  | SHEET 4 OF 4 REV A  |  |