

PART NUMBER	REV	FIRST USED
1385302-1	A	122500-1
1385302-2	A	565435-5
1385302-3	A	354500-1

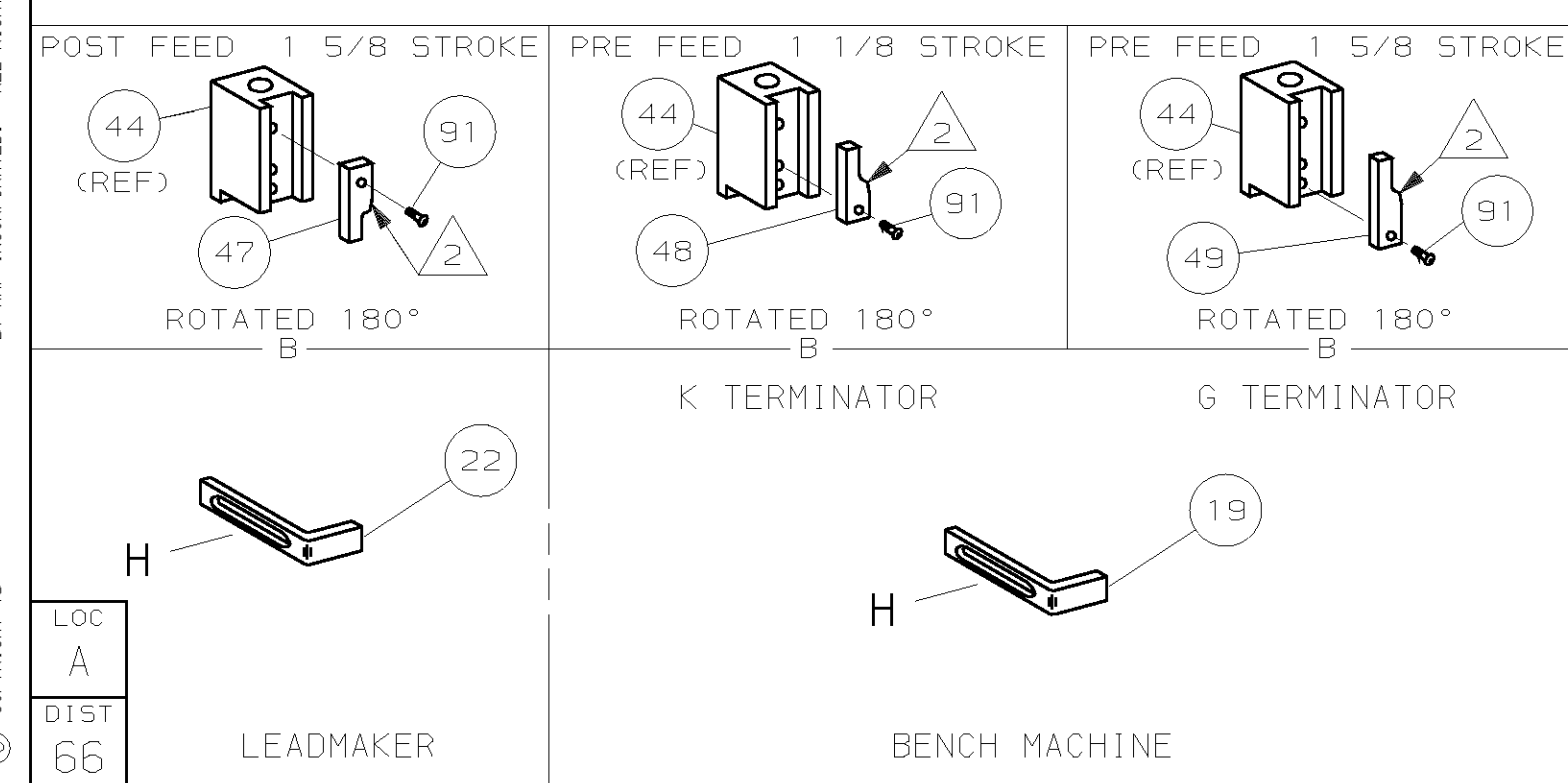
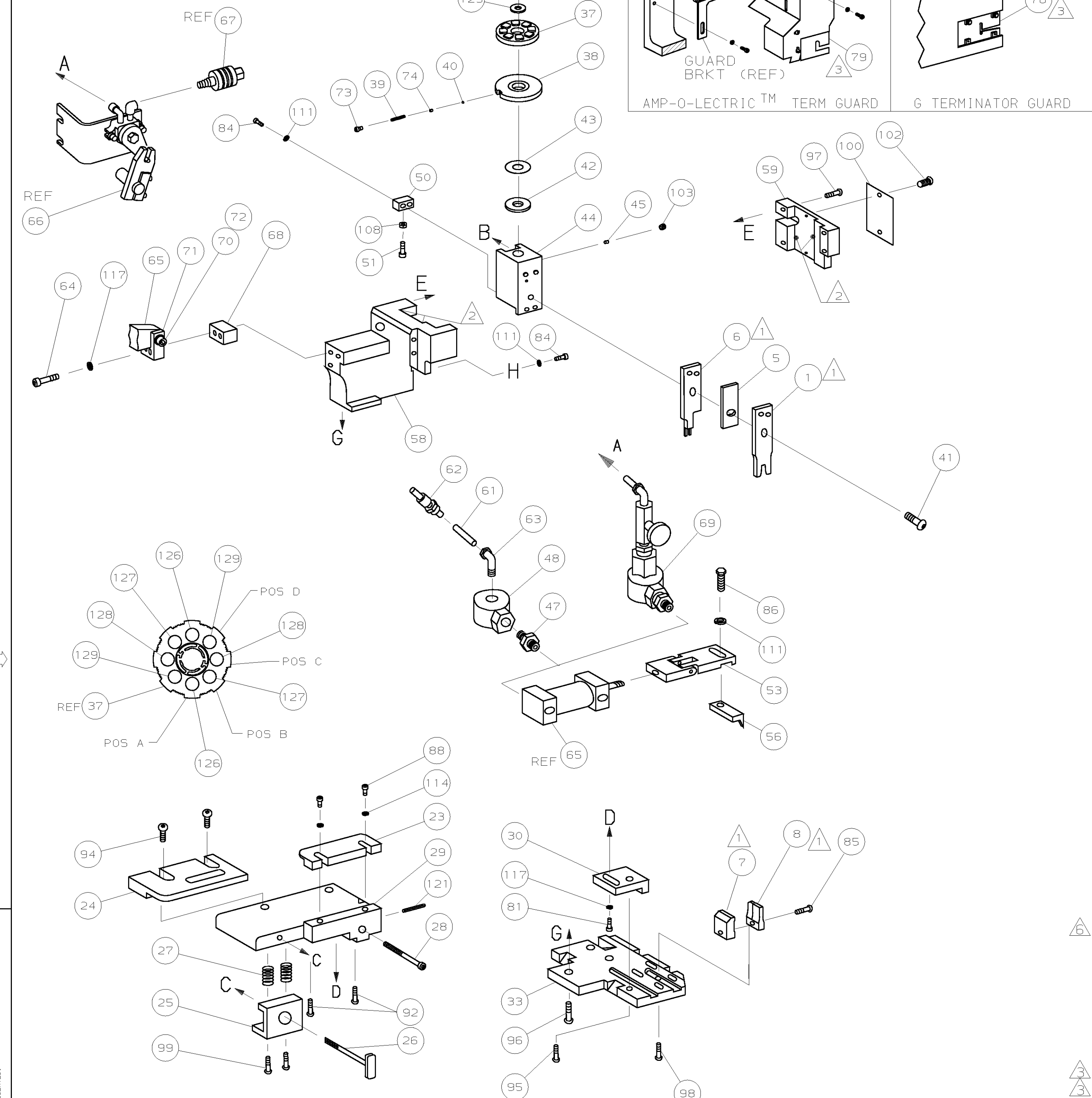

- 1 RECOMMENDED SPARE PARTS.
- 2 GREASE LIGHTLY.
- 3 GUARD MUST BE IN PLACE WHEN OPERATING APPLICATOR IN A BENCH MACHINE.
- 4 SEE DRAWING FOR COMPONENTS
- 5. ITEMS WITH QTY OF REF SPECIFIED (EXCEPT ITEMS 78 AND 79) ARE USED ON ITEM 46.
- 6 CUT TO LENGTH AT ASSY

TERMINAL NAME: TERMINAL, BLADE		286986		CRIMP DATA (NON-AMP TERMINAL-CUST SPEC)	
PAD LTR	CRIMP HEIGHT	WIRE SIZE			
A	.127 ±.002 [3.23 ±0.05mm]	14			
B	.120 ±.002 [3.05 ±0.05mm]	16			
C	.116 ±.002 [2.95 ±0.05mm]	18			
D	NOT USED	USED			
CRIMP WIRE	SIZE	TYPE	RANGE		
	.140 [3.56mm]	F	14-18		
INSUL	-	-	-		
WIRE STRIP LENGTH	TERM APPL SPEC	FEED	APPL INSTRUCTION	SET UP GAGE	LAYOUT
.208-.224	NONE	.310	408-8040	458637-1	L2563

QTY	RECD	PER	ASSY	PARTS LIST	DESCRIPTION	ITEM NO
2	2	2	-	C	4-354778-9	PIN, WIRE DISC (.2740)C 129
2	2	2	-	C	4-354778-1	PIN, WIRE DISC (.2700)B 127
2	2	2	-	C	2-354778-7	PIN, WIRE DISC (.2630)A 126
1	1	1	-	A	986950-1	WASHER, FLAT PRECISION 125
1	1	1	-	A	217238-1	GENERAL INSTRUCTION PACKAGE 124
1	1	1	-	-	4088040	SF APPL INST 408-8040 123
						122
1	1	1	-	A	4-21028-0	PIN, SLT SPR (ø.093x.75)ST GDE PL 121
1	1	1	-	A	1-21030-1	PIN, DOWEL (ø.187x.50)LEVER 120
1	1	1	-	A	1-21030-6	PIN, DOWEL (ø.187x1.25)HOUSING 119
1	1	1	-	A	21045-3	RING, RET "C" (ø.187)FD FING PIN 118
1	1	1	-	A	21024-5	WASHER, LOCK (#10)ADJ BLOCK 117
1	1	1	-	A	21024-5	WASHER, LOCK (#10)ADJ PLATE 116
1	1	1	-	A	21024-5	WASHER, LOCK (#10)FEED GDE ROD 115
2	2	2	-	A	21024-2	WASHER, LOCK (#4)FRONT STP GUIDE 114
1	1	1	-	A	5-21028-1	PIN, SLT SPR (ø.125x.50)ADJ ROD 113
						112
4	4	4	-	A	21024-4	WASHER, LOCK (#8)STRIPPER 111
1	1	1	-	A	21899-4	WASHER, FLAT (ø5/16)SCREW ADJ 110
						109
						108
1	1	1	-	A	21068-5	NUT, HEX (6-32)FEED ADJ 107
						106
						105
						104
1	1	1	-	A	21009-2	SCR, SKT 5ET (1/4-20x.25 LW)RAM 103
2	2	2	-	A	21017-2	SCR, DRIVE (#2x.19)ID PLATE 102
1	1	1	-	A	6-23715-5	SCR, PAN HD (6-32x1.50)FEED ADJ 101
1	1	1	-	B	461264-1	PLATE, IDENTIFICATION 100
2	2	2	-	A	3-21002-0	SCR, BHC (10-32x.88)DRAG 99
1	1	1	-	A	22733-8	SCR, BHC (8-32x.38 LW)ANVIL 98
1	1	1	-	A	2-21002-9	SCR, BHC (10-32x.75)CAP 97
1	1	1	-	A	2-22733-8	SCR, BHC (1/4-20x.62)HOUSING 96
1	1	1	-	A	2-21002-7	SCR, BHC (10-32x.50)56 ADJ BLOCK 95
4	4	4	-	A	2-21002-2	SCR, BHC (8-32x.50)TERM H DWN 94
						93
2	2	2	-	A	1-21002-4	SCR, BHC (4-40x.38)FENCE 92
1	1	1	-	A	1-21002-7	SCR, BHC (6-32x.38)CAM 91
						90
						89
2	2	2	-	A	1-21000-4	SCR, SHC (4-40x.38)F ST GUIDE 88
						87
1	1	1	-	A	2-22603-0	SCR, HEX HD (8-32x.31)FEED FINGER 86
1	1	1	-	A	2-21000-6	SCR, SHC (8-32x.38)SHEAR 85
3	3	3	-	A	2-21000-7	SCR, SHC (8-32x.50)STRIPPER 84
1	1	1	-	A	3-21000-7	SCR, SHC (10-32x.75)FEED ROD GD 83
1	1	1	-	A	3-21000-6	SCR, SHC (10-32x.62)FD ADJ BLK 82
1	1	1	-	A	3-21000-4	SCR, SHC (10-32x.38)56 ADJ BL 81
1	1	1	-	A	3-21000-4	SCR, SHC (10-32x.38)PIVOT BLK 80
-	-	-	-	B	455749-1	GUARD, WINDOW 79
REF	-	-	-	B	679532-1	INSERT, GUARD 78
						77
						76
						75
1	1	1	-	A	690603-1	SPRING, ASSIST 74
1	1	1	-	A	23030-1	SCR, SHC (6-32x.25 SL)INS DISC 73
1	1	1	-	A	4-21002-8	SCR, BHC (3/8x1.00)FEED MT 72
1	1	1	-	B	459610-3	MOUNT, FEED BRACKET 71
-3	-2	-1	U/M	DWG SIZE	PART NO	DESCRIPTION
						ITEM NO

QTY	RECD	PER	ASSY	PARTS LIST	DESCRIPTION	ITEM NO
-1					LEADMAKER	AIRFEED
-2					BENCH MODEL K	AIRFEED
-3					BENCH MODEL G	AIRFEED
1	1	1	-	A	21024-8	WASHER, LOCK (3/8)FEED BRKT 70
-	1	-	-	C	692655-5	AIR FEED VALVE ASSY 69
1	1	1	-	A	461690-1	SPACER, AIR FEED 68
-	REF	-	-	A	24042-2	VALVE, SHUT OFF 67
-	REF	-	-	C	692655-6	AIR FEED VALVE ASSY 66
1	1	1	-	B	461065-2	AIR FEED ASSY (2 INCH) 65
2	2	2	-	A	4-21000-3	SCR, SHC (10-32x2.00)AIR ASSY 64
1	-	1	-	A	980285-2	ELBOW, SWIVEL 1/8 NPT - 1/4 T 63
1	-	1	-	A	23238-1	QUICK DISCONNECT 62
21.00	-	21.00	IN	A	27319-4	TUBING, POLY-FLO ø.25 61
1	1	1	-	A	454178-1	GUIDE, FEED ROD 60
1	1	1	-	C	454220-1	CAP, RAM 59
1	1	1	-	D	454485-1	HOUSING 58
						57
1	1	1	-	B	1-694433-7	PAWL, FEED 56
1	1	1	-	B	240624-1	PIN, FEED FINGER 55
1	1	1	-	B	691499-1	SPRING, FEED FINGER 54
1	1	1	-	B	461062-1	FEED FINGER ASSY 53
1	1	1	-	A	455679-2	LEVER, TERMINAL FEED ARM 52
1	1	1	-	A	811242-2	BUMPER, HOLDDOWN 51
1	1	1	-	A	690753-1	SPACER, TONKER 50
1	-	-	-	B	690602-6	CAM, PRE-FEED 1 5/8 ST 49
1	-	1	-	A	22374-7	VALVE, QUICK EXHAUST 48
1	-	1	-	A	22304-1	NIPPLE, HEX 1/8 NPT 47
						46
1	1	1	-	A	690191-1	PLUG, NYLON 45
1	1	1	-	C	455673-2	RAM 44
1	1	1	-	A	690125-1	WASHER, LAMINATED 43
1	1	1	-	A	690124-7	WASHER, RAM 42
1	1	1	-	A	7-21002-9	BOLT, CRIMPER (5/16x1.00) 41
1	1	1	-	A	23241-6	BALL, STEEL 40
1	1	1	-	A	690170-1	SPRING, COMPRESSION 39
1	1	1	-	C	690142-1	DISC, INSULATION 38
1	1	1	-	D	354777-1	WIRE DISC, PLASTIC 37
1	1	1	-	A	22480-5	WASHER, SPRING 36
1	1	1	-	B	690212-1	POST, RAM 35
						34
1	1	1	-	D	455675-1	PLATE, BASE 33
1	1	1	-	A	690432-3	SCREW, ADJUSTMENT 32
						31
1	1	1	-	B	455689-1	BLOCK, STRIP GUIDE ADJ 30
1	1	1	-	C	1-455671-5	PLATE, STRIP GUIDE 29
1	1	1	-	A	690432-3	SCREW, ADJUSTMENT 28
2	2	2	-	A	1-22284-0	SPRING, DRAG 27
1	1	1	-	B	690546-1	LEVER, DRAG RELEASE 26
1	1	1	-	B	3-690754-0	DRAG, TERMINAL 25
1	1	1	-	D	8-690440-0	GUIDE, STRIP (REAR) 24
1	1	1	-	A	690712-2	GUIDE, STRIP (FRONT) 23
-	-	1	-	B	690472-2	STRIPPER 22
1	1	1	-	A	4-22284-9	SPRING, FEED RETURN 21
						20
1	1	-	-	B	690472-9	STRIPPER 19
						18
						17
						16
						15
						14
						13
						12
						11
						10
						9
1	1	1	-	C	1424383-1	ANVIL 8
1	1	1	-	A	1-853714-4	PLATE, REAR SHEAR 7
1	1	1	-	B	853721-7	BLADE, SLUG 6
1	1	1	-	B	455888-6	SPACER 5
						4
						3
						2
1	1	1	-	C	1424382-1	CRIMPER, WIRE 1
-3	-2	-1	U/M	DWG SIZE	PART NO	DESCRIPTION
						ITEM NO

DIMENSIONS IN INCHES. DO NOT SCALE PRINT. TOLERANCES UNLESS OTHERWISE SPECIFIED:		MATERIAL		FINISH	
2 PLC DEC ±					
3 PLC DEC ±					
4 PLC DEC ±					
ANGLES ±					
SURF TEXTURE:	✓				
REMOVE BURRS, BREAK SHARP EDGES R.015 MAX					
DR B.HIGMAN	07/19/01	APP T.ELBIN	07/19/01	AMP Incorporated Harrisburg, PA 17105-3608	
CHK B.HIGMAN	07/19/01	REL		NAME SIDE FEED HDM APPLICATOR MACHINE REF MINI APPL	
				SCALE	DWG NO 1385302 SHEET 1 OF 1 REV A1

THIS DRAWING IS A CONTROLLED DOCUMENT.

THIS DRAWING IS UNRELEASED. RELEASE FOR PUBLICATION BY AMP INCORPORATED. ALL RIGHTS RESERVED. AMP 1756 REV 3-92 14-APR-04 06:56:47 US016926

1385302