



# RF Coax Products



## Introduction

### Product Facts

- Listed under the Component Program of Underwriters Laboratories Inc., File No. E-81956 as indicated by Product Family**

- Recognized under the Component Program of Underwriters Laboratories Inc., File No. E-81956 as indicated by Product Family**

- Certified by Canadian Standards Association File No. LR 7189 as indicated by Product Family**

- Produced under a Quality Management System certified to ISO 9001**

A copy of the certificate is available upon request

The Tyco Electronics RF Coaxial catalog combines the best products from industry leading brand names like M/A-COM and AMP. We have integrated these into one cohesive set of RF products focused specifically on wireless, wireline carrier, and enterprise networking sectors of the world telecom equipment market.

Tyco Electronic's broadest selection of RF connectors and coaxial cable assemblies provides you with a solution for every interconnection requirement.

Type N and 7/16 connectors are used where high power and rugged reliability are required, typically as antenna feeds, filter/combiner I/O's, and power amplifier outputs. SMA, SMB, and TNC connectors are the primary cable interface for inner cabinet routing and are available in panel mount, board mount, and cable terminations. Subminiature connectors

such as MCX, SMP, DIN, and BlindMate provide panel to board and back-plane connections. Finally, our micro miniature SSMT, and MMCX series provide excellent board to board and card edge to board solutions.

All of these interfaces are supported with cable terminating tools and between series adapters to meet all your requirements for trouble free terminations at the lowest applied cost. The appendices hold a wealth of information including a Theory and Application tutorial, RG/U cable specification tables, Application notes on White Bronze plating and intermodulation distortion.

Whether you need rugged external RF power cables, panel mount, board to board, blindmate, or DIN, Tyco Electronics has the connection.

### How to Use This Catalog

Based on the communications gear that you are designing:

- Wireless Basestations
- Carrier Rack Equipment
- Chassis Set Top Box
- NIC Card

Typical equipment drawings on pages 306-309 guide you to the interconnect section(s) in this catalog.

Selection guides will direct you to products based on performance and mechanical requirements such as impedance, VSWR, max. frequency, power handling, etc.

There are other guides to help you find the right connection: A table of contents listed by interface type, a complete connector type selector describes each interface with typical applications, and a mini-selection guide shows key parameters to quickly pinpoint the right connector type.

### Need more information?

Call Technical Support at the numbers listed below.

Technical Support is staffed with specialists well versed in all Tyco Electronics products. They can provide you with:

- Technical Support
- Catalogs
- Technical Documents
- Product Samples
- Tyco Electronics Authorized Distributor Locations

### Restriction on the use of Hazardous Substances (RoHS)

At Tyco Electronics, we're ready to support your RoHS requirements. We've assessed more than 1.5 million end items/components for RoHS compliance, and issued new part numbers where any change was required to eliminate the restricted materials. Part numbers in this catalog are identified as:

**RoHS Compliant** — Part numbers in this catalog are RoHS Compliant, unless marked otherwise. These products comply with European Union Directive 2002/95/EC as amended 1 January 2006 that restricts the use of lead, mercury, cadmium, hexavalent chromium, PBB, and PBDE in certain electrical and electronic products sold into the EU as of 1 July 2006.

NOTE: For purposes of this Catalog, included within the definition of RoHS Compliant are products that are clearly "Out of Scope" of the RoHS Directive such as hand tools and other non-electrical accessories.

**Non-RoHS Compliant** — These part numbers are identified with a "◆" symbol. These products do not comply with the material restrictions of the European Union Directive 2002/95/EC.

NOTE: Information regarding RoHS compliance is provided based on reasonable inquiry of our suppliers and represents our current actual knowledge based on the information provided by our suppliers. This information is subject to change. For latest compliance status, refer to our website referenced at right.

### Getting the Information You Need

Our comprehensive on-line RoHS Customer Support Center provides a forum to answer your questions and support your RoHS needs. A RoHS FAQ (Frequently Asked Questions) is available with links to more detailed information. You can also submit RoHS questions and receive a response within 24 hours during a normal work week. The Support Center also provides:

- Cross-Reference from Non-compliant to Compliant Products
- Ability to browse RoHS Compliant Products in our on-line catalog
- Downloadable Technical Data Customer Information Presentation
- More detailed information regarding the definitions used above
- So whatever your questions when it comes to RoHS, we've got the answers at [www.tycoelectronics.com/leadfree](http://www.tycoelectronics.com/leadfree)

RoHS  
Customer  
Support  
Center



## RF Catalog Table of Contents

### Disclaimer

While Tyco Electronics Corporation and its affiliates referenced herein ("Tyco Electronics") have made every reasonable effort to ensure the accuracy of the information in this catalog, Tyco Electronics does not guarantee that it is error-free, nor does Tyco Electronics make any other representation, warranty or guarantee that the information is accurate, correct, reliable or current.

Tyco Electronics reserves the right to make any adjustments to the information contained herein at any time without notice. Tyco Electronics expressly disclaims all implied warranties regarding the information contained herein, including, but not limited to, any implied warranties of merchantability or fitness for a particular purpose. Tyco Electronics' only obligations are those in the Tyco Electronics Standard Terms and Conditions of Sale, and in no case will Tyco Electronics be responsible for any incidental, indirect, or consequential damages arising from the sale, resale, use, or misuse of its products. Users should independently evaluate the suitability of, and test each product for, their application.

The dimensions, specifications, designs, construction, materials and processes in this catalog are for reference purposes only and are subject to change without notice. Please consult Tyco Electronics for the most current product information.

The export of certain Tyco Electronics products is restricted by the Arms Export Control Act (Title 22, U.S.C. Sec 2751, et seq.) or the Export Administration Act of 1979, as amended (Title 50, U.S.C., App. 2401 et seq.). Orders may be subject to export approval by the U.S. Government. Buyer must comply with all applicable export laws of all applicable jurisdictions.

© Copyright 2007, 2000, 1998, 1994, 1992, 1990, and 1982 by Tyco Electronics Corporation.

All International Rights Reserved.

ACTION PIN, AMP, AMP-HDI, AMPLIMITE, AMP-O-LECTRIC, CERTI-CRIMP, COAXICON, M/A-COM, OSP, OSSP, PIDG, PRO-CRIMPER, RAYCHEM, SIEMAX, SMT/QuickGrip, SOLISTRAND, STAX, TE LOGO, TYCO ELECTRONICS and Z-PACK are trademarks.

AT&T is a trademark of AT&T Corporation. BELDEN is a trademark of Belden Wire and Cable Company.

BERK-TEK is a trademark of Nexans, Inc. COMM/SCOPE is a trademark of Commscope, Inc.

DANIELS is a trademark of Daniels Manufacturing Corporation.

GPO is a trademark of Corning Gilbert, Inc. HIROSE is a trademark of Hirose Electric.

MURATA is a trademark of Murata Electronics, Inc.

ROLM is a trademark of the Rolm Corp.

TPX is a trademark of Mitsui Chemicals America, Inc.

TROMPETER is a trademark of Trompeter Electronics, Inc.

VALOX is a trademark of General Electric Company.

Other products, logos, and company names mentioned herein may be trademarks of their respective owners.

See inside back cover for Global Contacts and phone numbers.

### Miniature Connectors

7-16 Series Connectors .....	7-11
Lightning Protection Connectors .....	12-19
Surge Protectors .....	12-15
λ/4 Wave Stub Tuners .....	16-19
N Series Connectors.....	20-25
Quick Lock N (QLN) Series Connectors .....	26-28
TNC Connectors .....	29-43
BNC Connectors.....	44-77
Mini BNC Connectors .....	78-81
Decoupled Connectors.....	82-87
Self-Terminating PC Board Connectors .....	88
Twin BNC Connectors.....	89-92
F Series and G Series Connectors .....	93-99

### Subminiature Connectors

SMA Connectors.....	100-123
QMA Connectors .....	124-128
DIN Connectors .....	129-156
Series 1.0/2.3 .....	129-137
Series 1.6/5.6 .....	138-146
Measurement Accessories.....	147-150
Coaxial Cables .....	151
SMP Connectors .....	152-156
Blind Mate Connectors .....	157-175
OSP Miniature Blind Mate Connectors .....	157-168
OSSP Subminiature Blind Mate Connectors.....	169-175
SMB Connectors.....	176-192
SMC Connectors.....	193-195
MCX Connectors.....	196-203
Compression Coax Board-to-Board Connectors.....	204
STAX Coax Connectors .....	205, 206

### Micro Miniature RF Coax Connectors

SMT/QuickGrip Connectors.....	207-211
SSMT Connectors .....	212-217
MMCX Connectors.....	218-221
UMCC Connectors.....	222-228
Switching Coax Connectors .....	229-236
Quick Snap Stripline (QSL) Connectors .....	237

### Multi Position Connectors

DIN Inserts .....	238-241
Size 8 Contacts .....	242, 243
COAXICON Contacts.....	244-248
SIEMAX Connectors .....	249, 250

### Between Series Adapters.....

.....	251-260
-------	---------

### Coaxial Terminations .....

.....	261
-------	-----

### Application Tooling .....

.....	262-268
-------	---------

### Cable Assembly Capabilities .....

.....	269-271
-------	---------

### Appendix

A - Theory and Application.....	272-277
B - White Bronze Application Note .....	278-280
C - Intermodulation Application Note .....	281-283
D - Typical Coaxial Cable Specifications .....	284-298
E - Maximum Power Handling Capabilities for Cables .....	299
F - Nominal Loss Characteristics for Cables.....	300
G - Glossary of Terms.....	301-305

### RF Coaxial Solutions for Communications Equipment Overview.....

.....	306-309
-------	---------

### RoHS Compliant to Non-RoHS Compliant Part Number Cross Reference .....

.....	310-312
-------	---------

### M/A-COM Part Number Cross Reference.....

.....	313, 314
-------	----------

### Part Number Index .....

.....	315-318
-------	---------



## Connector Selection

### Connector Types

**7-16 Series** connectors are designed for medium to high power applications such as cellular base stations, control components, antenna and broadcast. The 7-16 Series minimizes intermodulation distortion by white bronze or silver plating the electrical path. Combined hex/knurl coupling nuts allow for manual or torque tightening, further reducing distortion by providing a strong butt joint.

**Lightning Protection** devices have an integral surge arrester capsule which is designed to protect equipment from high current pulses. It is effective against very fast rise times as induced by electromagnetic pulses from nuclear explosions (NEMP) and the slower pulses arising from lightning strikes (LEMP).

**N Series** threaded connectors have an air dielectric interface and are low cost. These connectors operate to 11 GHz and are commonly used in cable-based local-area networks (LAN's) medium power transmitters, and base station antenna applications.

**TNC** connectors have an interface similar to BNC except for a threaded coupling nut. The tighter fit provided by this screw-on connection improves interface control allowing connectors to operate up to 11 GHz. TNC connectors are excellent for mobile units where top-notch performance is required under vibration.

**BNC** connectors offer easy engagement and disengagement using bayonet couplings and overlapping dielectrics. They are most useful for frequently coupled and uncoupled RF connections with frequencies below 4 GHz. BNC connectors find applications in flexible networks, instrumentation, and computer peripheral interconnections.

**F & G Series** connectors offer enhanced performance beyond 1 GHz. Designed to meet the rigorous requirements of Bellcore TA-NWT-001503 and SCTE specifications, the F & G series provides high current carrying capabilities in both sealed and un-sealed configurations. Plugs, jacks and adapters are available in threaded and push-on versions. These connectors meet the evolving needs of the communications industry for increased reliability and performance.

**SMA** threaded connectors are widely used in microwave communications. Connectors operate to at least 12.4 GHz on flexible coax cables, and up to 26.5 GHz on semi-rigid coax cables. Crimp-on SMA connectors that operate to 26.5 GHz are available.

**Blind Mate** connectors operate to 22 GHz for OSP connectors, 28 GHz for OSSP connectors, and 40 GHz for SMP style connectors. These connectors offer easy slide-on connection and require less alignment between the cable and the equipment than other connectors with comparable band width. Blind Mate connectors are widely used as coaxial interconnects between plug-in modules and motherboards when axial and radial misalignments are necessary.

**SMB** connectors feature a snap coupling for fast connection. A self centering outer spring and overlapping dielectric allows easy snap-on and excellent performance even in moderate vibration. The SMB is smaller in size than the SMA and excellent where engineers are concerned about circuit miniaturization. Typical application is inter- or intra-board connection of RF or digital signals. Commercial 50 ohm versions operate to 4 GHz, and 75 ohm versions reach 2 GHz.

**MCX** connectors offer a high reliability, space saving sub-miniature coaxial cable to cable and cable to board interconnection system. The MCX connectors impedance types are applicable up to 6 GHz.

**Surface Mount (SMT)** connectors. The RF solution to the communication and information age. Tyco Electronics' SSMT and SMT Quick Grip connectors are designed to meet the growing demand for surface mount RF connector technology. These connectors operate up to 6 GHz utilizing cable assembly design to terminate to SMT connectors. Surface mount connectors contribute to high density packaging and high volume manufacturing requirements.

**Multi Position** connectors. These connector series, including the 1.0/2.3 (CECC 22230), 1.6/5.6 (CECC 22240), Subminiature D (DIN 41652 and CECC 75 301-082), and Tyco Electronics' own SIEMAX multi coax connector series offer the customer a broad choice of options where density and performance are a major concern. The 1.0/2.3 series contacts are available in both 50 and 75 Ohm versions and are designed for use to 10 GHz. The different types of coupling mechanisms, such as screw on, slide-in and latching coupling provide for a variety of space-saving installations. The connector series 1.6/5.6 has been modified to incorporate improved technical advantages. A 75 Ohm design for use up to 8 GHz, it offers excellent screening effectiveness and is a most suitable component for those applications where the transmission of high bit rates is required. In Subminiature D type connectors these interfaces provide good electrical grounding and electromagnetic shielding in a small package size. These plug connectors address the increasing demands related to EMC (electromagnetic compatibility) and RFI (immunity to radiated noise), and are widely used as interface connectors in office and data systems, telecommunications equipment, and in measurement and control systems. Tyco Electronics' SIEMAX connectors combine the benefits of surface mount technology and modular design. This 75 Ohm connector series operates up to 2 GHz and offers a compact grid pitch of 10mm. Its uses include multiplex and high-density systems, and Base Station applications.

**Miscellaneous** connector types include multiple-circuit connectors that use coaxial contacts in a pin-and-socket configuration, crimp-on ferrules that offer fast, reliable connections for attaching one or more ground taps to shielded wire and braided shield terminations for connecting cable shields to pc boards. Also available are network/premises interconnect products for Ethernet/IEEE 802.3 systems and coaxial taps for simple, dependable connections from transceiver to LAN without cutting the cable.

## Connector Selection Guide

Product	Nominal Impedance Ohms	Maximum Frequency GHz	Temperature Rating C	Cable Retention		Coupling Mechanism	Maximum Peak Voltage	Durability Cycles	Connector Body Finish	Page No.
				lb	[N]					
7-16 Series	50	7	-55° to +155°	RG8A/U	—	Threaded	4000	500	White Bronze	7
Lightning Protection	50	2.5	-45° to +85°	Adapter	—	Threaded	650	500	White Bronze	12
N Series Commercial	50	11	-65° to +85°	90 (RG-214/U)	400.3	Threaded	1000	500	Nickel	20
TNC Single Crimp	50	7	-65° to +165°	60 (RG-58C/U)	266.9	Threaded	500	500	Silver	29
TNC Dual Crimp	50	11	-65° to +165°	60 (RG-58C/U)	266.9	Threaded	500	500	Silver or Nickel	29
TNC Commercial	50	7	-55° to +85°	60 (RG-58C/U)	266.9	Threaded	500	500	Nickel	29
TNC 75 Ohm	75	2	-55° to +85°	60 (RG-59B/U)	266.9	Threaded	500	500	Nickel	29
BNC Single Crimp	50	2.5	-65° to +165°	60 (RG-58C/U)	266.9	Bayonet	500	500	Silver or Nickel	44
BNC Dual Crimp	50	4	-65° to +165°	60 (RG-58C/U)	266.9	Bayonet	500	500	Silver or Nickel	44
BNC Dual Crimp Commercial	50	4	-55° to +85°	60 (RG-58C/U)	266.9	Bayonet	500	500	Nickel	44
BNC Hex Crimp	50	4	-55° to +85°	60 (RG-58C/U)	266.9	Bayonet	500	500	Nickel	44
BNC Field Serviceable	50	4	-65° to +165°	40 (RG-142B/U)	177.9	Bayonet	500	500	Nickel	44
BNC 75 Ohm	75	2	-65° to +85°	60 (RG-59B/U)	266.9	Bayonet	500	500	Nickel	44
Twin BNC	Non-constant	—	-55° to +85°	25 (RG-108/U)	111.2	Bayonet	500	200	Silver or Nickel	89
F Series	75	—	-55° to +85°	40 (Series 59, 6, 7 Single Braid)	—	Threaded (F)	500	200	Nickel	93
G Series	75	—	-55° to +85°	40 (Series 59, 6, 7 Single Braid)	—	Push-On (G)	500	200	Nickel	93
SMA Semi-Rigid	50	26.5	-65° to +105°	60 (RG-402/U)	266.9	Threaded	500	500	Gold or Passivated Stainless Steel	100
SMA Flexible	50	12.4	-65° to +165°	40 (RG-58C/U)	177.9	Threaded	500	500	Gold or Passivated Stainless Steel	100
SMP	50	40	-65° to +165°	20 (RG-405/U)	89	Snap-On	500	100	Gold	152
OSP Semi-Rigid	50	22	-65° to +125°	60 (RG-402/U)	267.02	Push-On	500	5000	Gold or Passivated Stainless Steel	157
OSP Flexible	50	12.4	-65° to +125°	40 (RG-58/U)	178	Push-On	335	5000	Gold or Passivated Stainless Steel	157
OSSP Semi-Rigid	50	28	-65° to +125°	20 (RG-405/U)	89	Push-On	335	5000	Gold or Passivated Stainless Steel	169
OSSP Flexible	50	—	-65° to +125°	20 (RG-316/U)	89	Push-On	250	5000	Gold or Passivated Stainless Steel	169
SMB	50	4	-65° to +85°	20 (RG-316/U)	89	Snap-On	335	500	Nickel	176
SMC	50	10	-65° to +85°	20 (RG-174/U)	89	Threaded	250	500	Gold	193
MCX Connectors	50	6	-65° to +165°	20 (RG-316/U)	32	Snap-On	500	500	Nickel	196
	75	6	-65° to +165°	20 (RG-187/U)	32	Snap-On	500	500	Nickel	196
SMT Quick Grip	50	3	-40° to +125°	Omni-Flex	—	Snap-On	250	5	Gold	207
SSMT	50	6	-40° to +125°	Omni-Flex	—	Snap-On	250	100	Gold	212
MMCX	50	6	-55° to +155°	10 (RG-178/U)	44.5	Snap-On	500	500	Gold	218
Mini BNC	75	2	-40° to +85°	20 (735A)	—	Bayonet	300	500	Nickel	78
QMA	50	6	-40° to +125°	20 (RG-316/U)	—	Quick Lock	335	100	Nickel	124
Comp. Coax	50	4	-40° to +125°	N/A	—	N/A	125	25	Gold	204
	50	10	-40° to +85°	—	—	Thread/Snap/Slide	500	500	—	129
DIN 1.0/2.3	75	2	-40° to +85°	—	—	Thread/Snap/Slide	500	500	—	129
	50	2.4	—	N/A	—	N/A	—	30,000	—	229

**Connector Selection** (Continued)

**Method of Termination**

Tyco Electronics provides connectors that can be terminated to coaxial cable, printed circuit boards or other connector interfaces.

Selection of the proper connector to terminate to an RG cable is simplified by using the format of this catalog. Experience has proven that certain connector types lend themselves to termination of particular coax cable sizes. For example, miniature cables such as RG 188 are most practically terminated to subminiature connectors such as SMB and SMC styles. Figure 3 illustrates the interface diameters of each connector type and the dielectric outside diameter (DOD) of popular RG cables. It is most economical to select a connector that terminates to a cable with a dielectric diameter close in size to the connector's interface diameter. The product information sections of this catalog have been organized so that all connector construction types are grouped together by cable size. This allows easy selection of the connector construction best suited for the application.

Tyco Electronics continually looks at new cable types and will release new part numbers based upon general market or specific customer needs. If you cannot find a Tyco Electronics part number for a specific cable type, please contact one of our sales locations or your local distributor to make an inquiry.

Tyco Electronics offers a wide range of connector configurations for terminating to printed circuit boards. Also available are connectors which allow the interconnection of one interface type to another.

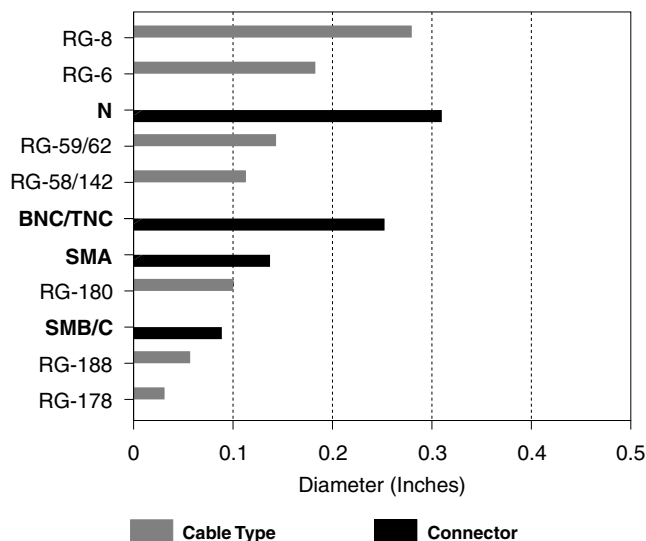

Figure 3

By reviewing this catalog, a connector can be found to match most any application. Since the RF connector is a part of a transmission line system, make sure when selecting a new connector design, that it is compatible with the overall system's performance.

**Construction**

The construction of a connector will greatly affect the purchase price. The connector tables in this catalog include construction details that allow you to select connectors that meet your requirements at the lowest price. Commercial designs use lower cost materials, such as zinc diecast bodies, polypropylene insulators and silver-plated contacts. Specific details of connector construction are listed in each product section of this catalog.

The materials used affect both performance and cost. Common base metals include brass, beryllium copper and stainless steel. The most common plating used for the center contact is gold because of its low contact resistance, superior mating properties and corrosion resistance.

PTFE, polypropylene and polymethylpentene (TPX) are the most common connector dielectrics. PTFE offers the lowest loss, the most stable electrical properties and high-est operating temperature. But since it cannot be injection molded, manufacturing is more costly than other materials. Be certain, when specifying connectors, that the temperature and voltage limitations are taken into consideration.

**Assembly**

There are several methods of assembly or termination, but they can be categorized into two major areas: (1) Solder center conductor and clamp braid (Category A) and (2) Crimp center conductor and crimp braid. Other methods are derived from combinations of the above, (e.g., solder center conductor and crimp braid. Method (1) (Category A) is generally used where no specialized tools are available, such as with field installations. With the development of low cost assembly tools, method (2) is becoming more popular for field installation.

**Crimping** is preferred in most manufacturing environments where assembly tooling is available because terminations can be made in the least amount of time and with the greatest reliability. The design of crimp tools assures that every termination is made the same; this cannot be done with a clamp design without further testing or inspection. Figure 4 illustrates the difference between braid crimping using AMP "O" crimp and the industry-standard hex crimp. The AMP "O" crimp gives a more consistent pressure on the outer collar. In addition, the crimp of the center conductor provides superior VSWR as shown in Figure 5.

Benefits derived by using AMP "O" crimp:

- No soldering of center contact is required. This alleviates all prospective problems associated with the soldering process such as excess solder, cold solder joints and overheating the dielectric.
- Fewer parts resulting in less assembly errors
- Braid crimping which eliminates the need for the combing, screwing and torquing associated with the braid clamp.

TPX is a trademark of Mitsui Chemicals America, Inc.

## 7-16 Series Connectors

### Product Facts

- Designed for cellular base-stations, control component, antenna and broadcast applications
- Available in White Bronze plating
- Minimizes Intermodulation Distortion by the use of non-ferrous materials
- Hex knurl for wrench tightening
- Available for several popular RG cable sizes in solder-clamp and crimp-crimp attachment styles



Tyco Electronics offers a comprehensive range of 7-16 Connectors to suit today's challenging Wireless Infrastructure Market. This market demands reliable, intermodulation sensitive connectors that accommodate higher power.

Tyco Electronics 7-16 Coaxial Connector Series provides reliable, intermodulation-minimizing solutions that also provide a logical alternative to N Series connectors in high power applications where a more rugged interface design is required. Typical examples of this include transmitter to antenna links and channel switching networks.

The 7-16 Series conforms to CECC 22190 and IEC 169-4 specification standards and has a 2.7kV working voltage at the connector interface and maximum power handling capability of 4kW.

The series has been designed for these demanding environments and can withstand a minimum of 500 mating cycles. Popular RG cable sizes are covered in both solder/clamp and crimp attachment styles. Two piece combination connectors adapt to straight or right-angle configurations, minimizing the number of different part codes needed by the customer. Series N to 7-16 between series adapters facilitate the transition between system interfaces as well as providing a test interface.

The increased customer demand for greater channel capacity combined with increased sensitivity of receivers has exposed the IMD (Intermodulation Distortion) phenomenon. To address this problem 7-16 Connectors have been

designed to reduce IMD through the use of non-ferrous base materials and by silver plating of the electrical path. The proprietary White Bronze plating technique is standard, providing high corrosion resistance, low porosity, scratch resistance, low RF loss and a non-magnetic finish. Incorporation of hex-knurl coupling nuts allow for hand or wrench tightening of connectors, depending upon the application.

Tyco Electronics is a global ISO 9001 certified manufacturer and maintains a complete in-house Intermodulation Testing facility. Connector part numbers shown form just a small part of the extensive interconnect package that Tyco Electronics offers for the professional wireless and telecom markets.

### Related Product Data

**N Connectors** — Pages 20-25

### Application Notes —

White Bronze — Appendix B  
Intermodulation — Appendix C

### Between Series Adapters

For 7-16 Series Between Series Adapters, see pages 251-260.

**7-16 Series Connectors** (Continued)

**General Specifications**
**Materials**

Female Contacts (inner and outer)	Beryllium Copper
Other Metal Parts	Brass
Insulators	Fluorocarbon Polymer
Gaskets	Silicone Rubber
Finishes	
Parts in the electrical path	Silver over copper
Other Metal Parts	White Bronze

**Electrical**

Frequency Range	DC-7GHz
Impedance	50 Ohms
Insulation Resistance	10,000 Megohms Minimum 2.7kV (connector)
Maximum Working Voltage rms (sea level)	1.4kV (versions for RG 213, 214 and 393)
Maximum Proof Voltage rms (sea level)	2.7kV (connector) 1.4kV (versions for RG 213, 214 and 393)
Center Contact Resistance	0.8 milliohm (max.) after conditioning
Insertion Loss	<1.5dB to 5 GHz
VSWR	1.02 + 0.03f up to 7 GHz where f is measured in GHz
Intermodulation	Better than -150dBc

**Mechanical**

Coupling Torque	18.5 – 22 ft.-lbs.
Proof Torque	25 ft.-lbs.
Mechanical Endurance	500 mating cycles

**Environmental**

Temperature Rating	-55°C to +155°C
--------------------	-----------------



**7-16 Series Connectors** (Continued)

**Straight Cable Plug  
Solder/Solder**

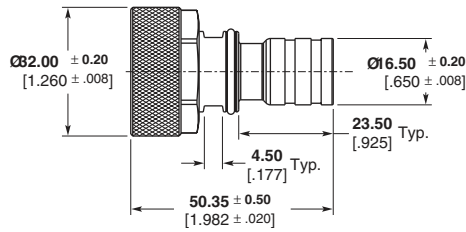

Cable Type	Body Plating	Part No.
1/2" Corrugated	White Bronze/ Gold	<b>1460159-1</b>

**Straight Cable Plug  
Crimp/Crimp**

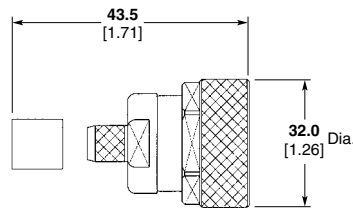

Cable Type	Body Plating	Part No.
RG 8A/U, RG 213/U	White Bronze	<b>6331959-1</b>
RG 9B/U, RG 214/U	White Bronze	<b>6362765-1</b>

**Right-Angle Cable Plug  
Solder/Crimp**

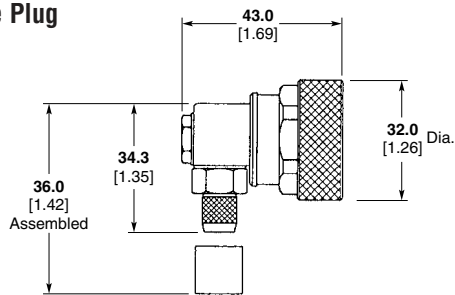

Cable Type	Body Plating	Part No.
RG 58C/U, RG 141A/U	White Bronze	<b>6408028-1</b>
RG 213/U	White Bronze	<b>6408030-1</b>
RG 214/U	White Bronze	<b>6312113-1</b>

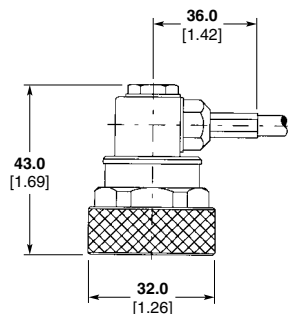

**Note:** Part Numbers are RoHS compliant except: ♦ Indicates non-RoHS compliant.

**7-16 Series Connectors (Continued)**

**Right-Angle Cable Plug Solder/Clamp**

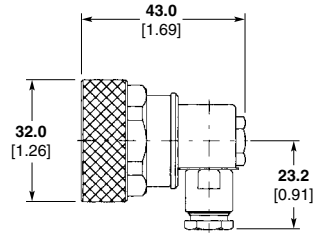

Cable Type	Body Plating	Part No.
RG 55B/U, RG 58C/U, RG 141A/U, RG 142B/U, RG 223/U, RG 400/U	White Bronze	6408026-1
T-Flex 402	Silver	6328873-1

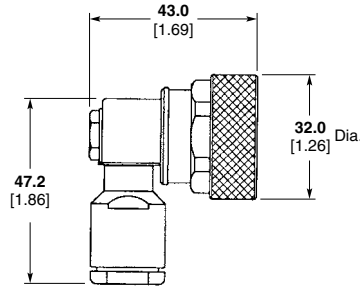

Cable Type	Body Plating	Part No.
RG 213/U, RG 214/U, RG 393/U	White Bronze	6408027-1
RG 8A/U, RG 9B/U, RG 213/U, RG 214/U	White Bronze	6408038-1

**Straight Panel Mount Cable Jacks Crimp/Crimp**

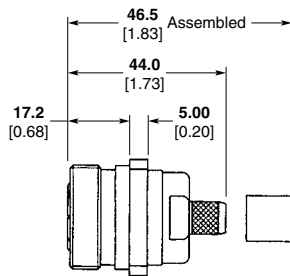

**Mounting Detail**

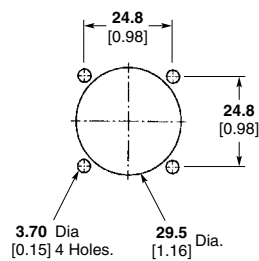

Cable Type	Body Plating	Part No.
RG 8A/U, RG 213/U	White Bronze	6408032-1
RG 9B/U, RG 214/U	White Bronze	6408033-1

**Panel Socket Launcher**

**Mounting Detail**

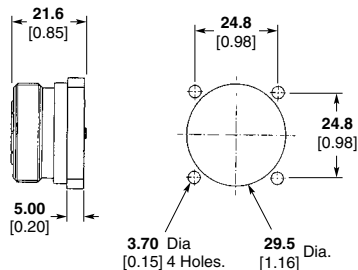

Body Plating	Part No.
White Bronze	6311225-1
White Bronze	1460052-2

**Note:** Part Numbers are RoHS compliant except: ♦ Indicates non-RoHS compliant.

**7-16 Series Connectors** (Continued)

**Right-Angle Panel Jack Solder/Clamp**

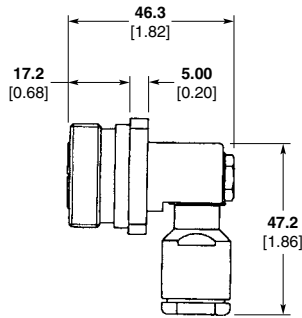

**Mounting Detail**

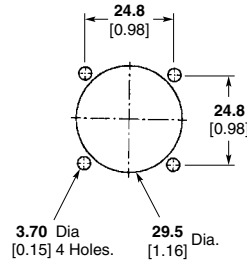

Cable Type	Body Plating	Part No.
RG 213/U, RG 214/U, RG 393	White Bronze	6408036-1
RG 58C/U, RG 142B/U, RG 223/U, RG 400/U	White Bronze	6363527-1

**Combination Panel Jack Solder/Crimp**

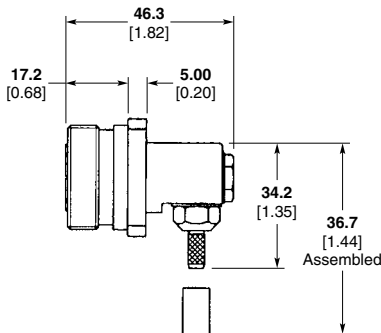

**Mounting Detail**

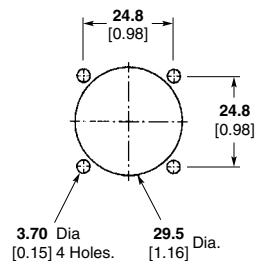

Cable Type	Body Plating	Part No.
RG 55B/U, RG 142B/U, RG 233/U, RG 400/U	White Bronze	6363524-1
RG 8A/U, RG 213/U	White Bronze	6363525-1
RG 9B/U, RG 214/U	White Bronze	6363526-1

**Bulkhead Adapter Jack/Jack**

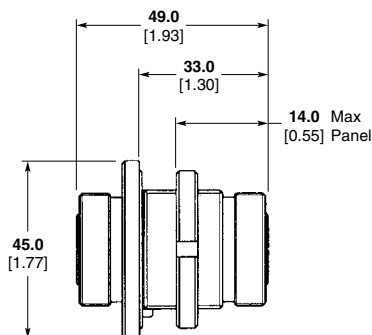

Body Plating	Part No.
White Bronze	6408037-1

**Note:** Part Numbers are RoHS compliant except: ♦ Indicates non-RoHS compliant.

## Lightning and EMP Protection Devices

### Product Facts

- Cellular operator protection against EMP (electro-magnetic pulses) caused by lightning strikes
- Two different categories: Surge protectors and Quarter wave stub tuners
- For use in cellular infrastructure including GSM, DCS 1800, and PCS 1900 systems
- Incorporates Gas Discharge Tube (GDT) technology



Tyco Electronics has developed a unique series of Lightning and EMP protection devices for use in cellular infrastructure including GSM, DCS 1800, and PCS 1900 systems. These devices are designed to offer the cellular operator protection against EMP (electro-magnetic pulses) caused by lightning strikes. Direct or even near strikes produce fast rising electric fields within micro-seconds. These fields generate high voltage pulses through unprotected antennas and transmission lines which lead to the primary communication equipment. High voltage pulses can cause extensive damage leading to costly repairs as well as significant loss of service to

subscribers. These protective devices come in two different categories: surge protectors and quarter wave stub tuners.

To ensure that proper, low level contact resistance is established between the LP device and mounting wall, it is recommended that a minimum torque of 50 in/lbs / 5.65 n/m be applied to tighten the connector mounting nut. A recommended minimum torque of 35 in/lbs / 3.95 n/m should also be applied for installation of replacement surge protector capsules to ensure proper protection performance.

In order to ensure that resultant currents from lightning or EMP strikes do not

interfere with parallel transmission lines within protected electronic equipment, surge protector devices must be installed with proper orientation. The surge protector side of the device should be mounted in the unprotected side of the equipment while the mounting nut is positioned internally in the protected area.

It is important when planning lightning protection, that the user can estimate the potential number of direct strikes. This information may influence the type of device selected or the requirement for routine maintenance checks. Significant attention must be paid to the height of sup-

porting structure as this, when related to the typical number of thunderstorms in a particular region, allows us to estimate the probability of a direct strike taking place. To assist our customers in this, the following table and chart has been included in this note. This should enable lightning protection planners to establish the likelihood of direct strikes across a network anywhere in the world.

Detailed application notes are available for proper selection of lightning protection devices (surge protectors & stub tuners) as well as intermodulation and White Bronze plating.

### Selecting your RF Coaxial Lightning Protection Device

#### Between Series Adapters

For 7-16 Series and N Series Between Series Adapters, please see pages 251-260.

Number of Thunderstorm Days per year	hmax/m 10%	hmax/m 20%	hmax/m 50%
05	28	39	61
10	18	26	40
15	14	20	31
20	12	17	26
30	9.4	13	20
40	7.9	11	17
50	6.9	9.5	15
70	5.6	8.0	12
90	4.8	7.0	10.6
130	3.9	5.5	8.5
150	3.5	5.0	7.7
180	3.1	4.4	6.9

**Table 1:** Maximum height of supporting building for a given number of thunderstorm days (when hmax is exceeded, probability of direct strike to supporting building within 15 years is greater than 10% for hmax values given in second column, 20% for hmax values given in third column and 50% for hmax values given in the fourth column).



## Surge Protectors

### Product Facts

- Excellent for Broadband Frequency Applications
- Field Replaceable Gas Discharge Tube
- Available Interfaces Facilitate Retrofit Capabilities
- Low VSWR up to 2.5GHz
- Specialized White Bronze Finish



### Selection of a Lightning Protection Device

At right are the basic advantages and limitations for both types of protection to use in the proper selection for your application.

### Advantages

- Broadband
- Allows DC bias on the transmission line. (critical for applications using mast top electronics.)
- No harmonic passband
- Ease of retrofitting antenna sights
- GDT easily accessible for replacement

### Limitations

- Routine maintenance recommended
- 3 GHZ maximum frequency
- Initial pass-through voltage

These devices incorporate Gas Discharge Tube (GDT) technology. A GDT is a hermetically sealed tube containing an inert gas. The tube is inserted in the side of the device through an easily accessible weather sealed port. During normal operation the tube is inactive. When an installation is struck by lightning, a high voltage impulse will appear on the coaxial line. As the impulse amplitude rises, a level is reached where the impulse surpasses the dynamic voltage threshold of the tube and the electrodes arc over to discharge the energy to ground. Prior to activation of the tube, there will be a short period of time where energy will be present on the line. This *residual pulse* is equal to the dynamic voltage threshold of the tube. The maximum impulse voltage a tube can handle without discharging is referred to as the *impulse sparkover voltage*. This capacity of the GDT is quoted as follows:

Characteristic	Symbol	Definition	Impulse	Typical Value
Impulse sparkover voltage	$U_{zdyn}$	Dynamic voltage threshold	1kV/ $\mu$ S	650V

In the case of the referenced chart, the voltage will rise at one kilovolt per microsecond and the tube will fire after 650 nanoseconds. During activation a small percentage of voltage (called arc voltage) will still pass through. This will be approximately 30 volts. When the pulse subsides, the tube again becomes inactive leaving a small *residual voltage* on the line. A direct lightning strike results in an impulse current of high amplitude. The capability of a device to protect a system is defined as the *impulse discharge current* rating. This is defined as the peak current of an impulse which the device can withstand ten times (5 at each polarity at fixed intervals) without affecting the device. *maximum impulse discharge current* is the peak current of an impulse the device can withstand once.

Surge protectors are often used in applications requiring a standing DC line voltage. This is typical in applications with mast top electronics. The maximum voltage capacity of a surge protector prior to it surpassing the static voltage threshold and discharging it to ground is defined as its D.C.

**Surge Protectors (Continued)**

*sparkover voltage.* This capacity is quoted as follows:

Characteristic	Symbol	Definition	Impulse	Typical Value
d.c. sparkover voltage	$U_{zstat}$	Static voltage threshold	n/a	230V

In these applications it is important to select a device that will assure the tube can return to its inactive state after the passage of a surge. This feature of the Surge protector is known as the *holdover voltage*. If the device continues to conduct, the protected line will be short circuited and the tube will heat up (glow mode). If left in this state, the tube can overheat and

destruct. GDT's have a finite life span which is inversely proportional to the energy dissipated. At extremes it is possible to reach a level where the tube is unable to discharge all the energy and is destroyed. It is therefore necessary to schedule routine maintenance checks and periodically replace the tube within the surge protector.

Surge protectors offer excellent lightning protection for broadband systems and are usable up to 3 GHz. Standard interfaces include 7-16, N, and SMA. Configurations include straight and bulkhead mounted adapters which allows for ease of assimilation into existing systems.

**Specifications**

Requirement	Detail
<b>Electrical</b>	
Frequency Range	DC to 3GHz
Impedance	50Ω
VSWR Performance	≤ 1.33:1
Insertion Loss (Typical)	0.45dB
Impulse Discharge Current (8/20μs, multiple strike)	20kA
Maximum Impulse Discharge Current (8/20μs, single strike)	50kA
Dynamic Sparkover Voltage, NEMP (1kV/μs)	2,000V
Dynamic Sparkover Voltage, LEMP (1kV/μs)	800V
Dynamic Sparkover Voltage, Static (<100V/μs)	90V*
<b>Materials</b>	
Body Parts	Brass
Gaskets	Silicone Rubber
Female Contacts	Beryllium Copper
Male Contacts	Brass
Insulators	P.T.F.E.
<b>Environmental</b>	
Operating Temperature Range	-45° C to +85° C
Relative Humidity	up to 100%

\* Determined by gas tube used, can be higher than value shown.

**N Series Jack to SMA Bulkhead Jack Adapter**

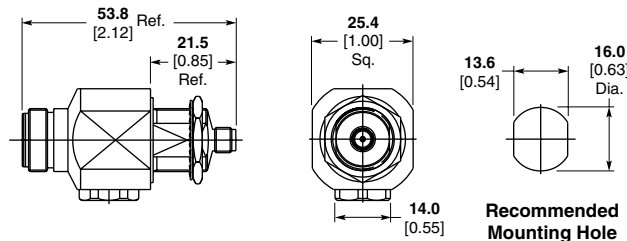

**Recommended Mounting Hole**

Frequency Range	DC to 3GHz
Contact Plating	Gold
Body Plating	White Bronze
Max Panel	10.00mm
Compliant With	CECC22210/ CEC22110
Coupling Torque	0.7-1.1Nm
Proof Torque	1.7Nm both ends
Endurance	500 Matings

**Part Number**  
**6312079-1**

**Note:** Part Numbers are RoHS compliant except: ♦ Indicates non-RoHS compliant.

**Surge Protectors** (Continued)

**N Series Jack to N Series Bulkhead Jack Adapter**

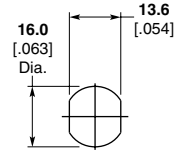
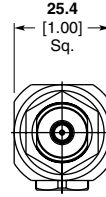
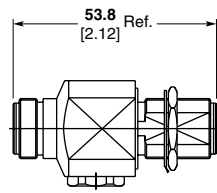

**Recommended Mounting Hole**

Frequency Range	DC to 3.0 GHz
Contact Plating	Gold
Body Plating	White Bronze
Max Panel	10.00mm
Compliant With	CECC22210
Coupling Torque	0.7-1.1 Nm
Proof Torque	1.7 Nm
Endurance	500 Matings

**Part Number**

**6312138-1**

**7-16 Plug to 7-16 Jack Adapter**

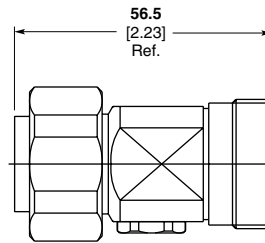
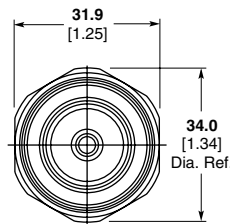

Frequency Range	DC to 3.0 GHz
Contact Plating	Silver
Body Plating	White Bronze
Compliant With	CECC22190
Coupling Torque	25 - 30 Nm
Proof Torque	35Nm
Endurance	500 Matings

**Part Number**

**6312121-1**

**Gas Discharge Tube Replacement**



**Part Number**

**1402314-1**

d.c. Sparkover Voltage:	230V ± 46V
Impulse Sparkover Voltage:	700V typ.
(1kV/mS)	(900V max)
Glow Discharge Voltage:	72V
Arc Discharge Voltage:	10V
a.c. Discharge Current:	20A
(1 sec, 50Hz)	
Impulse Discharge Current:	20kA (50kA for
(8/20mS waveform)	one strike)
Insulation Resistance (@100V):	10GW
Capacitance:	2pF

**Note:** Part Numbers are RoHS compliant except: ♦ Indicates non-RoHS compliant.

**$\lambda/4$  Stub Tuners**

**Product Facts**

- Ideal for use with GSM, PCS and DCS
- Maintenance Free Operation
- Low VSWR Within Specified Bandwidth
- Configurations include direct attachments to Cable variants
- Optional White Bronze Finish



**Advantages**

- Low VSWR in pass-band
- Minimal maintenance
- Pass-through voltage eliminated
- No sparkover or residual voltage concerns
- Ease of retro-fitting antenna sights

**Limitations**

- Frequency specific
- Harmonic passband
- Does not allow DC bias on transmission line

These devices are three port coaxial connectors. The third port extending from the main through path is terminated in a short circuit at a pre-determined distance calculated to be exactly one quarter wavelength at the desired center frequency (see graph).

Unlike surge protectors, this design eliminates concerns about residual pulse, sparkover voltage and residual voltage ensuring greater protection for sensitive electronic equipment. As opposed to surge protectors, stub tuners will absorb lightning strikes without need for replacing components. These devices yield very low VSWR and feature high attenuation within a relatively narrow pass-band ( $\pm 70$  MHz) but are application specific. Stub tuners also pass energy in bands that are harmonically related to the fundamental center frequency. The graphs below show a typical test impulse and the response of a stub tuner.

Stub tuners are classified into two broad categories—simple and broadband. The simple stub tuner exhibits a V-shaped response on the VSWR vs. frequency plot. The trough of the V is designed to occur at the required  $F_0$  and the bandwidth is restricted to approximately 8%. The broadband tuner employs extra RF techniques, similar to multiple cavity filtering, which increase the effective bandwidth by approximately 20%.

Tyco Electronics offers a wide variety of stub tuners for the most popular frequency bands to facilitate purchase without need for custom design and manufacturing. Designs exist for GSM, PCS 1900, DCS 1800

frequencies with standard industry interfaces including SMA, 7-16, and Type N. Configurations include cable assemblies, cabled connectors, and adapters for ease of assimilation into existing systems. Stub tuners are maintenance free since they incorporate no active components though it is recommended that a check of the stub tuner affixment be made following heavy discharges at an installation.

**Typical Test Impulse**

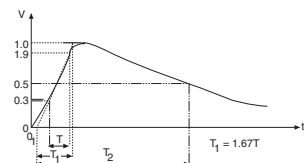

**Typical  $\lambda/4$  Test Response**

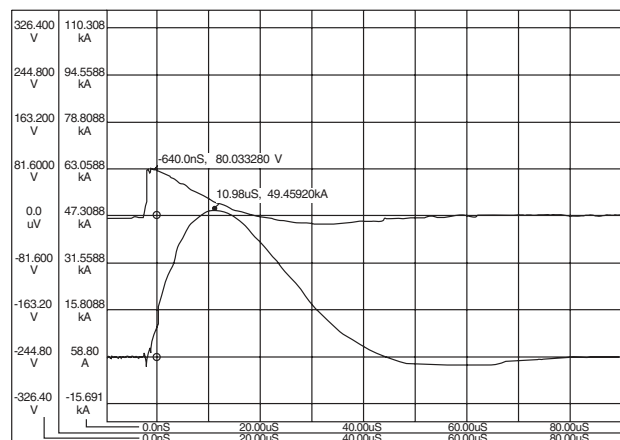

**$\lambda/4$  Shorting Stub Basics**

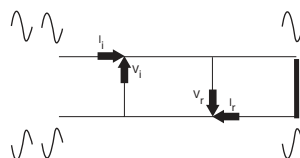



**$\lambda/4$  Stub Tuners** (Continued)

Requirement	Detail (Type-N, 7-16)
<b>Electrical</b>	
Impedance	50 $\Omega$
VSWR Performance in Band	$\leq 1.2:1$
Insertion Loss (Typical)	0.2dB
DC Resistance (stub outer to inner)	1m $\Omega$
Dynamic Voltage @ 250A/ms	$\leq 15V$
Residual Voltage @ 2500A, 8/20 $\mu$ s	$\leq 15V$
Outer Conductor Contact Resistance	10m $\Omega$
DC Resistance (through-path center contact)	100m $\Omega$
<b>Materials</b>	
Body parts	Brass
Gasket	Silicone Rubber
Female contacts	Beryllium Copper
Male Contacts	Brass
Insulators	P.T.F.E.
<b>Environmental</b>	
Operating temperature range	-45°C to +85°C
Relative humidity (non-condensing)	up to 100%

**DCS 1800**

**Type N Clamp Bulkhead Jack**

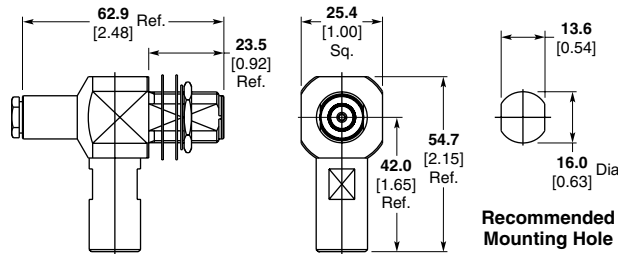

Bandwidth	$\pm 70$ MHz
Center Frequency	1795 MHz
Contact Plating	Silver
Body Plating	Silver
Max Panel	10.00mm
Compliant With	CECC22210
Coupling Torque	0.7-1.1Nm
Proof Torque	1.7Nm
Endurance	500 Matings

Cable	Part No.
T-Flex402	6329818-1

**7-16 Jack to 7-16 Bulkhead Jack Adapter**

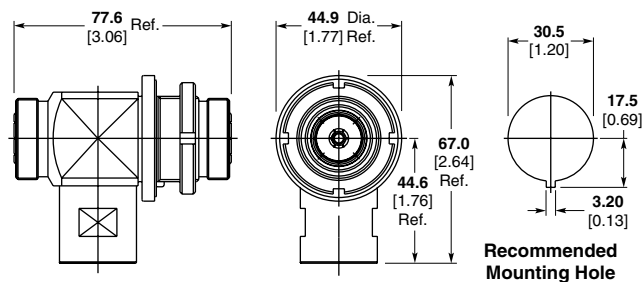

Bandwidth	$\pm 70$ MHz
Center Frequency	1795 MHz
Contact Plating	Silver
Body Plating	White Bronze
Max Panel	8.00mm
Compliant With	CECC22190
Coupling Torque	25 - 30Nm
Proof Torque	35Nm
Endurance	500 Matings

Part Number
6361137-1

**Note:** Part Numbers are RoHS compliant except: ♦ Indicates non-RoHS compliant.

**$\lambda/4$  Stub Tuners (Continued)**

**DCS 1800 (Continued)**

**Type N Crimp Bulkhead Jack**

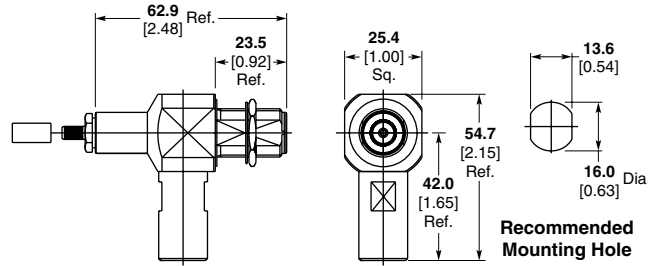

Cable	Part No.
RG58C/U	1329819-1

Bandwidth	± 70 MHz
Center Frequency	1795 MHz
Contact Plating	Silver
Body Plating	Silver
Max Panel	10.00mm
Compliant With	CECC22210
Coupling Torque	0.7-1.1Nm
Proof Torque	1.7Nm
Endurance	500 Matings

**Type N Jack to Type N Bulkhead Jack Adapter**

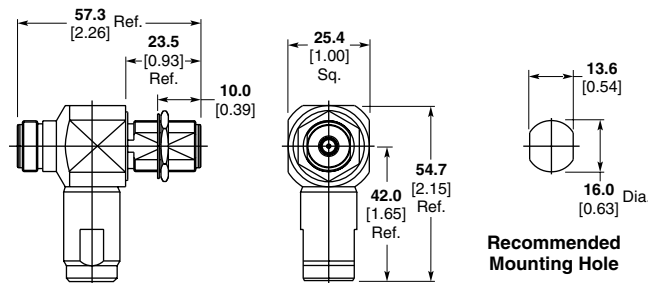

Part Number
1361138-1

Bandwidth	± 70 MHz
Center Frequency	1795 MHz
Contact Plating	Silver
Body Plating	Silver
Max Panel	10.00mm
Compliant With	CECC22210
Coupling Torque	0.7-1.1Nm
Proof Torque	1.7Nm
Endurance	500 Matings

**GSM**

**7-16 Bulkhead Jack to 7-16 Bulkhead Jack**

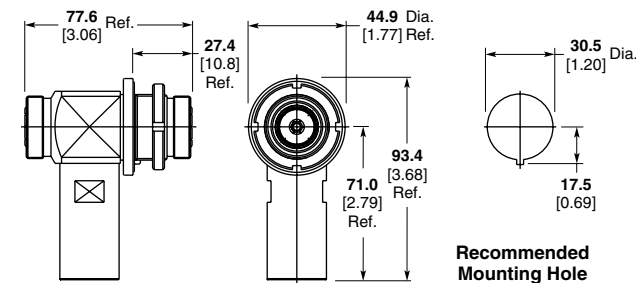

Cable	Part No.
T-Flex 402 Cable	6408399-1

Bandwidth	± 70 MHz
Center Frequency	925 MHz
Contact Plating	Silver
Body Plating	White Bronze
Max Panel	8.00mm
Compliant With	CECC22190
Coupling Torque	25 - 30Nm
Proof Torque	35Nm
Endurance	500 Matings

**PCS 1900**

**Type N Clamp Bulkhead Jack**

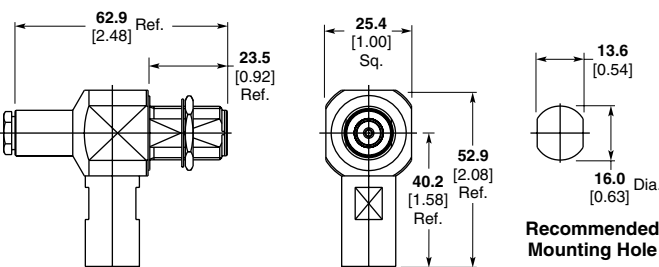

Cable	Part No.
T-Flex 402	1312137-1

Bandwidth	± 70 MHz
Center Frequency	1920 MHz
Contact Plating	Silver
Body Plating	Silver
Max Panel	10.00mm
Compliant With	CECC22210
Coupling Torque	0.7-1.1Nm
Proof Torque	1.7Nm
Endurance	500 Matings

**Note:** Part Numbers are RoHS compliant except: ♦ Indicates non-RoHS compliant.

**$\lambda/4$  Stub Tuners (Continued)**

**PCS 1900 (Continued)**

**Type N Crimp Bulkhead Jack**

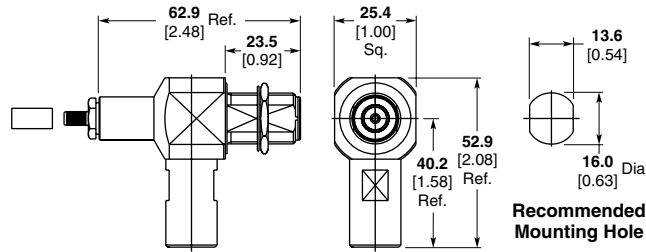

Bandwidth	± 70 MHz
Center Frequency	1920 MHz
Contact Plating	Silver
Body Plating	Silver
Max Panel	10.00mm
Compliant With	CECC22210
Coupling Torque	0.7-1.1Nm
Proof Torque	1.7Nm
Endurance	500 Matings

Cable	Part No.
RG58 C/U	6312139-1

**7-16 Clamp Bulkhead Jack**

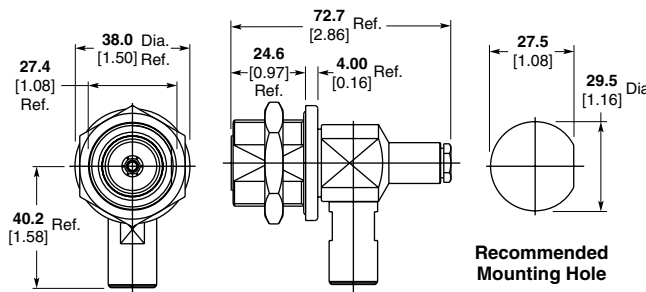

Bandwidth	1920 MHz
Center Frequency	± 70 MHz
Contact Plating	Silver
Body Plating	Silver
Max Panel	8.00mm
Compliant With	CECC 22190
Coupling Torque	25-30 Nm
Proof Torque	35 Nm
Endurance	500 Matings

Cable	Part No.
T-Flex402	6312123-1

**7-16 Bulkhead Jack to 7-16 Bulkhead Jack Adapter**

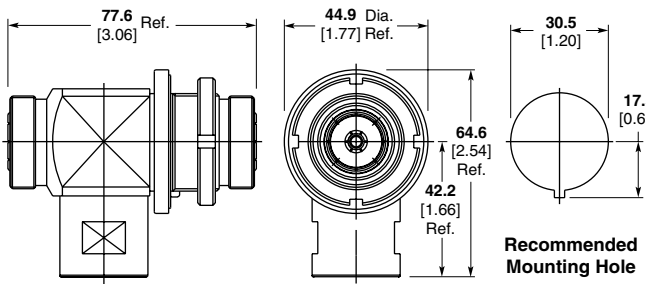

Bandwidth	1920 MHz
Center Frequency	± 70 MHz
Contact Plating	Silver
Body Plating	White Bronze
Max Panel	8.00mm
Compliant With	CECC 22190
Coupling Torque	25-30 Nm
Proof Torque	35 Nm
Endurance	500 Matings

Part Number
6312124-1

**Type N Bulkhead Jack to Type N Bulkhead Jack Adapter**

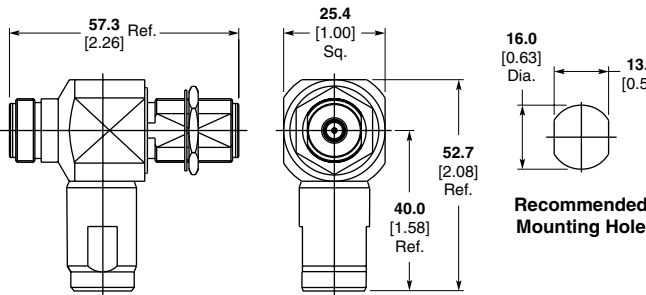



Bandwidth	± 70 MHz
Center Frequency	1920 MHz
Contact Plating	Silver
Body Plating	Silver
Max Panel	10.00mm
Compliant With	CECC22210
Coupling Torque	0.7-1.1Nm
Proof Torque	1.7Nm
Endurance	500 Matings

Part Number
6361139-1

**Note:** Part Numbers are RoHS compliant except: ♦ Indicates non-RoHS compliant.

## N Series Connectors

### Product Facts

- Designated connectors are MIL-C-39012, Class II, Category B qualified
- Captive center contacts
- Completely crimpable application – one hand tool crimps all cables with single or double braided shields of a given size
- Impedance matching crimps
- Broad band performance – low VSWR
- Superior cable retention
- PTFE dielectric
- Silver or nickel finish
- Fully intermateable with MIL-C-39012 connectors
- Listed under the Component Program of Underwriters Laboratories Inc., File No. E81956 
- Recognized under the Component Program of Underwriters Laboratories Inc., File No. E81956 
- Certified by Canadian Standards Association File No. LR 7189 

The Tyco Electronics N Connector, featuring a 15.88 [5/8] - 24 threaded coupling for optimum stability, is highly suited for critical applications and environments. This medium sized connector can withstand shock and vibration to assure a low noise level and has a constant impedance of 50 ohms. It also features a captive center contact and provides excellent performance at frequencies up to 11 GHz, with voltages to 1000 volts rms.

This Tyco Electronics connector offers the added benefits of low overall applied cost with a labor-saving two-crimp assembly. The contact is simply crimped to the cable's center conductor, then both braid and cable support are simultaneously crimped to complete the termination.

N Series Connectors are available in standard plug, jack, panel jack, bulkhead jack and right-angle plug configurations. Those connectors with a military designation (M39012) are furnished in accordance with all requirements of specification MIL-C-39012, Class II, Category B.

### Materials

- Brass**—QQ-B-626
- Beryllium Copper**—QQ-C-530
- Dielectric**—PTFE—MIL-P-19468
- Copper, Annealed**—QQ-C-576
- Phosphor Bronze**—QQ-B-750
- Silicone Rubber**—ZZ-R-765

### Plating

- Body**—  
Silver per QQ-S-365  
Nickel per QQ-N-290
- Center Contact**—  
Gold per MIL-B-45204



### Electrical Characteristics

- Nominal Impedance**—50 ohms
- Working Voltage**—1000 volts, rms at sea level
- Frequency Range**—0 to 11 GHz
- Voltage Standing Wave Ratio (VSWR)**—  
Straight Plug or Jack — 1.3:1 max.  
Right-Angle Plug —  
1.35 max. at 0 to 9.0 GHz  
1.50 max. at 9.0 to 11.0 GHz
- Contact Resistance**—  
Outer Contact—0.2 milliohms  
Center Contact—1.0 milliohms  
Right-Angle—2.5 milliohms
- Insulation Resistance**—5000 megohms min.
- Dielectric Withstanding Voltage**—2500 Volts, rms at sea level
- RF Leakage**—MIL Type, -90 dB min. at 2 to 3 GHz
- RF Insertion Loss**—MIL Type, 0.15 dB max. at 10 GHz  
Right-Angle Plug, 0.3 dB max. at 10 GHz
- Corona Level**—MIL Type, 500 volts min. at 21 336 m [70,000 ft.]
- Terminator**—  
Resistance—50 ohms  $\pm$ 1%  
Power Rating—1.0 watt max.

### Mechanical Characteristics

- Mating/Unmating**—Threaded coupling
- Cable Attachment**—Crimp type - center contact and braid
- Coupling Nut Retention**—445 N [100 lbs.] min.
- Cable Retention**—400 N [90 lbs.] min. RG 214/U Cable
- Durability**—500 cycles per MIL-C-39012
- Captive Contact**—27 N [6 lbs.] min. axial retention, either direction

### Environmental Characteristics

- Temperature Range**—  
MIL Type, -65°C to +165°C  
Commercial, -55°C to +85°C
- Vibration**—MIL-STD-202, Method 204, Test Cond. B
- Shock**—MIL-STD-202, Method 213, Test Cond. I
- Moisture Resistance**—MIL-STD-202 Method 106
- Salt Spray**—MIL-STD-202, Method 101, Test Cond B
- Temperature Cycling**—MIL-STD-202, Method 107, Test Cond. B (except high temperature is +85°C)
- Note:** All data pertains to use with MIL-C-39012 specified cables only.

### Between Series Adapters

For N Series Between Series Adapters, see pages 251-260.

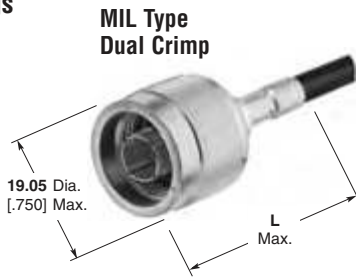
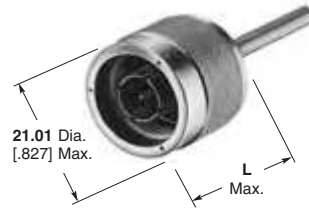
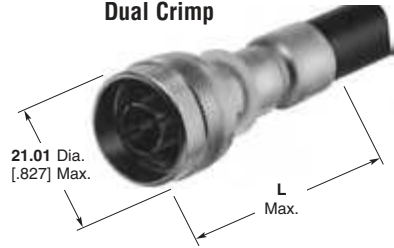

**N Series Connectors, 50 Ohm (Continued)**
**Plugs**

**Semi-Rigid Cable**

**Hex Dual Crimp**

RG/U Cable	Termination Type	Body Plating	M39012/ Military No. and/ or Comments	Dim. L	Integral Die Hand Tool	Hex Across Flats		Notes	Part No.
						Center	Braid		
58, 58A, 58B, 58C	O Crimp	Nickel	Knurl Collar	42.85 1.687	220045-2	—	—	1	1-5225661-2
	O Crimp	Silver	Knurl Collar	42.85 1.687	220045-2	—	—	1	5225361-1
223, 55, 55A, 55B	O Crimp	Nickel	Knurl Collar	42.85 1.687	220045-2	—	—	1	1-5225661-3
	O Crimp	Silver	Knurl Collar	42.85 1.687	220045-2	—	—	1	5225361-2
142, 142A, 142B, 400	O Crimp	Silver	Knurl Collar	42.85 1.687	220045-2	—	—	1, 3	5225392-2
			Knurl Collar	42.85 1.687	220045-2	—	—	1	5225361-4
142, 142A, 142B	O Crimp	Nickel	Knurl Collar	41.35 1.628	220045-2	—	—	3	5225699-1
	Hex Crimp	Nickel	Knurl Collar	39.40 1.550	58436-1	1.73 .068	5.41 .213	2	5415232-4
115A, BELDEN 89880, 9880	O Crimp	Nickel	Knurl Collar	42.85 1.687	220015-1	—	—	3	5225092-8
BELDEN 9880	Hex Crimp	Nickel	Knurl Collar	39.40 1.550	58485-1	2.54 .100	10.90 .429	2	1-415232-0
402 Semi Rigid (.141)	Solder	Nickel	Knurl Collar	24.6 .970	—	—	—	—	6057088-1
405 Semi Rigid (.085)	Solder	Nickel	Knurl Collar	24.6 .970	—	—	—	—	6057094-1
8, 8A, 213	O Crimp	Nickel	Knurl Collar	42.85 1.687	220015-1	—	—	—	1-5227086-0
	O Crimp	Nickel	Knurl Collar	42.85 1.687	220015-1	—	—	—	5225661-2
	O Crimp	Silver	01B007 Knurl Collar	42.85 1.687	220015-1	—	—	3	51692-2
	O Crimp	Nickel	Knurl Collar	47.22 1.859	220015-1	—	—	3	5225662-2
11, 11A, 216	O Crimp	Silver	01B0013 Knurl Collar	42.85 1.687	220015-1	—	—	3	51692-4
BELDEN 9292	O Crimp	Nickel	—	47.22 1.859	220015-1	—	—	3	1-5225662-8
393	Hex Crimp	Nickel	Hex Collar	39.40 1.550	58485-2	3.25 .128	10.90 .429	2	5414160-5
BELDEN 8214	O Crimp	Nickel	Knurl Collar	42.85 1.687	220015-1	—	—	—	1-5225661-6
9, 9A, 9B, 214	O Crimp	Nickel	Knurl Collar	42.85 1.687	220015-1	—	—	—	5225661-1
	O Crimp	Silver	01B0008 Knurl Collar	42.85 1.687	220015-1	—	—	3	51692-1
9, 214	Hex Crimp	Nickel	Hex Collar	39.40 1.550	58485-1	2.54 .100	10.90 .429	2	5415232-7
LMR 240	Hex/Solder	Silver	Hex Collar	29.74 1.171	—	—	6.81 .268	—	6274532-1

**Notes:** <sup>1</sup> Hand Tool 69710-1, with Die Insert 220062-1, is available to terminate these connectors. The 626 Pneumatic tool system can also be used.

<sup>2</sup> Die Set Crimp Tool — PRO-CRIMPER II Hand Tool, P/N 354940-1 or 626 Series Pneumatic Tool with 679304-1.

<sup>3</sup> Weatherproof.

BELDEN is a trademark of Belden Wire and Cable Company.

**Note:** Part Numbers are RoHS compliant except: ♦ Indicates non-RoHS compliant.

**N Series Connectors, 50 Ohm (Continued)**
**Right-Angle Plugs, Crimp**

RG/U Cable	Termination Type	Body Plating	M39012/ Military No. and/ or Comments	Dim. L	Integral Die Hand Tool	Hex Across Flats		Notes	Part No.
						Center	Braid		
58A, 58C	Hex Crimp	Nickel	Hex Collar	57.79 2.275	58436-1	1.73 .068	5.41 .213	1	5415255-1
142, 142A, 142B	Hex Crimp	Nickel	Hex Collar	57.79 2.275	58436-1	1.73 .068	5.41 .213	1	5415255-2
8, 8A, 213	O Crimp	Nickel	Knurl Collar	57.79 2.275	220015-1	—	—	—	5225669-2
	O Crimp	Silver	05B0002 Knurl Collar	57.79 2.275	220015-1	—	—	—	225014-2
8, 213	Hex Crimp	Nickel	Hex Collar	57.79 2.275	58485-1	2.54 .100	10.90 .429	1	5415255-3
393	O Crimp	Silver	Knurl Collar	62.31 2.453	220015-1	—	—	1,3	225389-6
9, 9A, 9B 214	O Crimp	Nickel	Knurl Collar	57.79 2.275	220015-1	—	—	—	5225669-1
	O Crimp	Silver	05B0003 Knurl Collar	57.79 2.275	220015-1	—	—	—	225014-3
9, 214	Hex Crimp	Nickel	Hex Collar	57.79 2.275	58485-1	2.54 .100	10.90 .429	1	5415255-4

**Notes:** 1 Die Assembly compatible with Crimp Tool — PRO-CRIMPER III Hand Tool, P/N 354940-1, 626 Series Pneumatic Tool 1213855-1, SDE Battery Tool Kit 1725837-1, or SDE Electric Terminator 1490076-2.  
3 Weatherproof.

**Jacks**



RG/U Cable	Termination Type	Body Plating	M39012/ Military No. and/ or Comments	Dim. L	Integral Die Hand Tool	Hex Across Flats		Notes	Part No.
						Center	Braid		
58A, 58C	O Crimp	Nickel	—	44.83 1.765	220045-2	—	—	2, 3	1-5225664-2
142, 142A, 142B	Hex Crimp	Nickel	—	41.28 1.625	58436-1	1.73 .068	5.41 .213	2	5415242-2
8, 8A, 213	O Crimp	Silver	02B0008	49.20 1.937	220015-1	—	—	3	225093-2
8, 213	O Crimp	Nickel	—	49.20 1.937	220015-1	—	—	2, 3	5225664-2
9, 9A, 9B, 214	O Crimp	Silver	02B0009	49.20 1.937	220015-1	—	—	—	225093-1
9, 214	O Crimp	Nickel	—	49.20 1.937	220015-1	—	—	2, 3	5225664-1
393	Hex Crimp	Nickel	—	41.28 1.625	58485-1	2.54 .100	10.90 .429	2	5415242-6
402 Semi Rigid (.141)	Solder	Nickel	—	26.70 1.051	—	—	—	—	6057116-1

**Notes:** 1 Hand Tool 69710-1, with Die Insert 220062-1, is available to terminate these connectors. The 626 Pneumatic tool system can also be used.  
2 Die Assembly compatible with Crimp Tool — PRO-CRIMPER III Hand Tool, P/N 354940-1, 626 Series Pneumatic Tool 1213855-1, SDE Battery Tool Kit 1725837-1, or SDE Electric Terminator 1490076-2.  
3 Weatherproof.

**Note:** Part Numbers are RoHS compliant except: ♦ Indicates non-RoHS compliant.

**N Series Connectors, 50 Ohm (Continued)**

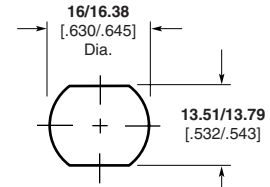
**Bulkhead Jacks, Crimp**



Maximum Panel Thickness 6.35 [.250]  
Recommended Panel Cutout

RG/U Cable	Termination Type	Body Plating	Dim. L	Integral Die Hand Tool	Hex Across Flats		Notes	Part No.
					Center	Braid		
58, 58A, 58B, 58C, LMR195	O Crimp	Silver	49.61 1.953	220045-2	—	—	1	5225363-1
58A, 58C	Hex Crimp	Nickel	45.72 1.800	58436-1	1.73 .068	5.41 .213	2	5415248-1
142, 142A, 142B	Hex Crimp	Nickel	45.72 1.800	58436-1	1.73 .068	5.41 .213	2	5415248-7
124, 140, 210, 62, 62A, 62B, 59, 59A, 59B, BELDEN 9291, 9209, 9269, 89269	O Crimp	Nickel	49.61 1.953	220045-3	—	—	—	1-5225667-6
8, 213	O Crimp	Silver	53.98 2.125	220015-1	—	—	2, 3	225094-2
393	O Crimp	Nickel	53.98 2.125	220015-1	—	—	2, 3	1-225668-1
9, 214	O Crimp	Silver	53.98 2.125	220015-1	—	—	2, 3	225094-1

**Notes:** 1 Hand Tool 69710-1, with Die Insert 220062-1, is available to terminate these connectors. The 626 Pneumatic tool system can also be used.  
2 Die Assembly compatible with Crimp Tool — PRO-CRIMPER III Hand Tool, P/N 354940-1, 626 Series Pneumatic Tool 1213855-1, SDE Battery Tool Kit 1725837-1, or SDE Electric Terminator 1490076-2.  
3 Weatherproof.

**Bulkhead Jacks for Semi-Rigid Cable**

**Rear Mount**

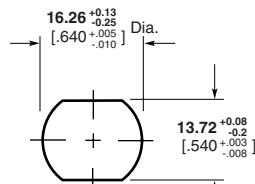

Maximum Panel Thickness 6.35 [.250]  
Recommended Panel Cutout

**Front Mount**

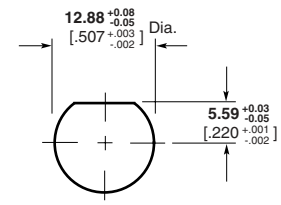
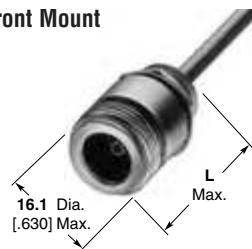

Maximum Panel Thickness 6.35 [.250]  
Recommended Panel Cutout

RG/U Cable	Termination Type	Body Plating	M39012/ Military No. and/or Comments	Dim. L	Integral Die Hand Tool	Part No.
402 Semi-Rigid/.141	Crimp	Nickel	Rear Mount	29.37 1.156	*	228658-1
	Solder	Pass. Gold	Rear Mount	—	*	6057159-1
	Solder	Nickel	Rear Mount	25.4 1.00	—	6057176-1
405 Semi-Rigid/.085	Solder	Nickel	Rear Mount	33.9 1.335	—	6057165-1

\*Tooling—Hand Tool No. 59980-1, Requires (2) Crimping Dies No. 312253-1 and (1) Locator No. 220220-2.

BELDEN is a trademark of Belden Wire and Cable Company.

**Note:** Part Numbers are RoHS compliant except: ♦ Indicates non-RoHS compliant.



**N Series Connectors, 50 Ohm (Continued)**

**Panel Mount Jack, Press-Fit**

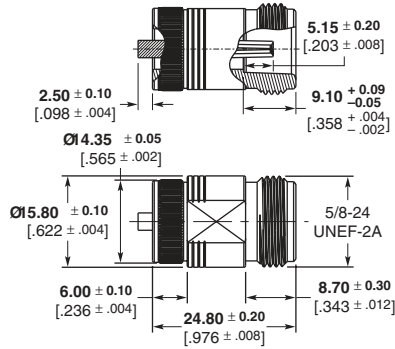

Body Plating	Contact	Dielectric	Part No.
White bronze	Gold	PTFE	1460055-1

**Panel Mount Jack, Screw-In**

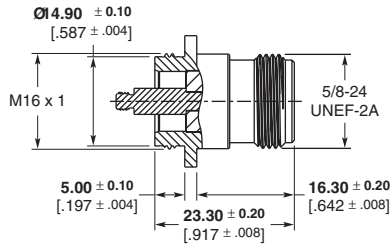

Body Plating	Contact	Dielectric	Part No.
White bronze	Gold	PTFE	1460118-1 <sup>1</sup>
White bronze	Gold	PTFE	1460118-2 <sup>2</sup>
White bronze	Gold	PTFE	1460118-3 <sup>3</sup>

**Notes:** 1. Without TUF-LOC Adhesive  
 2. With TUF-LOC Adhesive around M3 thread  
 3. With TUF-LOC Spot on M3 thread

**Feedthru Jack Adapter (Jack-Jack)**

**Plating**

**Body** — Nickel  
**Dielectric** — General purpose polypropylene  
**Contact** — Gold plated



Part Number
227945-2

**Inter-Series Adapters**

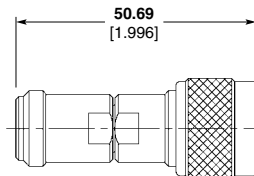

**Jack-Plug**

Type	Body Plating	Contact	Dielectric	Part No.
Jack-Plug	Stainless steel/passivate	Gold	PTFE	1057374-1

**Note:** Part Numbers are RoHS compliant except: ♦ Indicates non-RoHS compliant.



## Quick Lock N (QLN) Series Connectors

### Product Facts

- Similar performance and applications to standard N Series
- Time saving and user friendly snap on/off mating
- Excellent performance to 6 GHz
- No torquing of connector required
- Free rotation of mated connection
- Higher packaging density can be achieved
- Fully compatible with Huber&Suhner and Radiall QN Series QLF® connectors\*



### Description

Snap-on version of the popular N Series connector

- Snap-on interface facilitates assembly
- Same dependable performance as standard N connector

### Applications

- Cellular & PCS Base Stations
- Broadcast equipment
- Telephony applications, WLAN
- Instrumentation and remote measuring equipment
- Mil Aero, SatCom, Radar

### Material and Finish

**Shell** — Brass, plated white bronze  
**Male Pin Center Contact** — Brass, plated gold  
**Female Socket Center Contact** — Beryllium copper, plated gold  
**Outer Contact** — Phosphor bronze, plated white bronze  
**Insulators** — PTFE or PFA

### Electrical Characteristics

**Characteristic Impedance** — 50 ohms  
**Frequency Range** — DC to 6 GHz  
**Voltage Standing Wave Ratio (VSWR)** — 1.12 max. DC to 3 GHz  
**Insertion Loss** — 0.15 dB max. DC to 3 GHz  
**Rated Voltage** — 1000 VAC rms, 50 Hz (at sea level)  
**Insulation Resistance** — 5000 megohms min.  
**Contact Resistance** — Center Contact — 1.5 milliohms max. Outer Contact — 1.5 milliohms max.

### Mechanical Characteristics

**Engagement Force** — 30 N typical  
**Disengagement Force** — 30 N typical  
**Interface Retention Force** — 450 N min.  
**Contact Captivation** — 28 N min.  
**Durability** — 100 cycles min.

### Environmental Characteristics

**Operating Temperature** — -40°C to +125°C (cable dependent)  
**Thermal Shock** — IEC 60169 para. 16.4  
**Corrosion** — MIL-STD-202, Method 101, Condition B  
**Vibration** — IEC-1169-1 para. 9.3.3 (10-500 Hz, 5g)  
**IP Rating for Interface** — IP68 (connector dependent)

### Related Product Data

**Internet** — <http://tycoelectronics.com/products/rfcoax>

**Product Specification/Design Objectives** — 108-2281

\* QN and QLF are registered trademarks of Huber&Suhner, Inc. and Radiall S.A.. Huber&Suhner, Inc. and Radiall S.A. are not affiliated with the QLN product.

**Quick Lock N (QLN) Series Connectors** (Continued)

**Semi-Rigid Cable —  
Direct Solder Attachment**

**Straight Cable Plug**

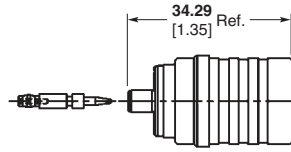

Cable	Part No.
RG 402	1274805-1

**Bulkhead Cable Jack**

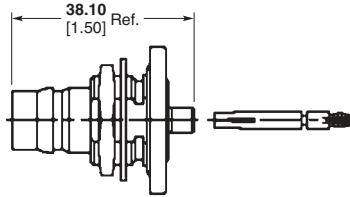

Cable	Part No.
RG 402	1274806-1

**Flexible Cable —  
Crimp Attachment**

**Straight Cable Plug**

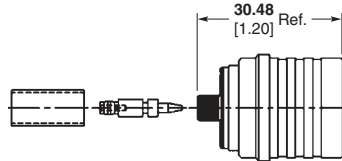

Cable	Part No.
RG 58	1274688-1
RG 142	1274688-2
LMR 240	1274688-3

**Straight Cable Jack**

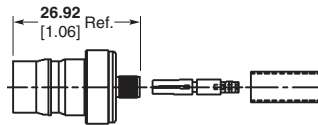

Cable	Part No.
RG 58	1274689-1
RG 142	1274689-2
LMR 240	1274689-3

**Right-Angle Cable Plug**

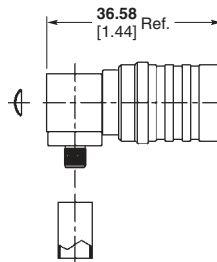

Cable	Part No.
RG 58	1274804-1
RG 142	1274804-2
LMR 240	1274804-3

**Bulkhead Cable Jack**

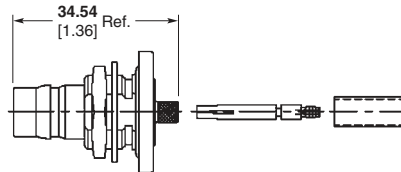

Cable	Part No.
RG 58	1274734-1
RG 142	1274734-2
LMR 240	1274734-3

**4-Hole Square Flange  
Cable Jack**

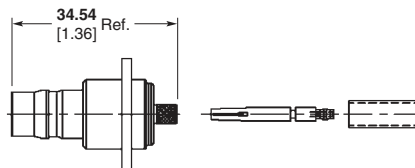

Cable	Part No.
RG 58	1274735-1
RG 142	1274735-2
LMR 240	1274735-3

**Note:** Part Numbers are RoHS compliant except: ♦ Indicates non-RoHS compliant.

**Quick Lock N (QLN) Series Connectors** (Continued)

**Panel Mount Receptacles**

**Press-Fit Bulkhead Jack Receptacle — Solder Terminal**

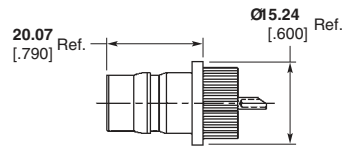

<b>Part Number</b>
1274807-1

**4-Hole Flange Jack Receptacle — Solder Terminal**

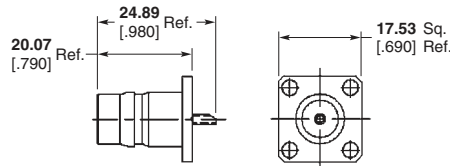

<b>Part Number</b>
1274662-1

**Adapters — Between Series**

**QLN Plug to N Series Jack**

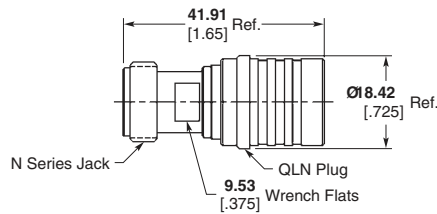

<b>Part Number</b>
1274808-1

**Note:** Part Numbers are RoHS compliant except: ♦ Indicates non-RoHS compliant.

## TNC Connectors

### Product Facts

#### Hex Crimp and O Crimp Connectors

- 50 and 75 ohm commercial versions available
- Provides excellent performance at frequencies up to 7 GHz
- Low cost commercial type available
- Commercial type is smaller and lighter weight
- Tarnish resistant nickel finish
- Choice of dielectric materials
- Standard and weatherproof versions available
- Plugs available for high temperature cable

#### Single Crimp Connectors

- Fast application—one crimping operation terminates inner conductor, outer braid and cable support
- Low application cost

#### Connectors for Semi-Rigid Cable

- Crimp and solder versions available
- Standard cable stripping dimensions
- Universal cable termination common to all configurations

Listed under the Component Program of Underwriters Laboratories Inc.,  File No. E81956

PC Board connectors are recognized under the Component Program of Underwriters Laboratories Inc.,  File No. E81956

Certified by Canadian Standards Association  File No. LR 7189

The Tyco Electronics TNC RF connector family, with 7/16-28 threaded couplings, provides low noise levels and optimum stability, and can withstand the shock and vibration often present in hostile environments.

Available in both 50 and 75 ohm versions, these connectors feature numerous styles including cable type plugs and jacks, adapters and printed circuit board connectors. These connectors accept a wide range of coaxial cables and are intermateable with industry standard connectors designed to MIL-C-39012 specifications.

Single crimp connectors provide reduced application time and lower applied costs. This is accomplished by using Tyco Electronics one-crimp operation tooling which simultaneously terminates the inner conductor, outer braid and cable support with one controlled stroke.

Tyco Electronics can also supply low-cost alternatives with a commercial type product line. These connectors are designed around the mil-specifications, offering comparable mechanical and electrical performance.



### Between Series Adapters

For TNC Between Series Adapters, see pages 251-260.

### Related Product Data

**Military Category** — All crimp connectors are Category B Type (Tyco Electronics Crimp Tooling), unless otherwise noted.

**Packaging** — All Mil-Type connectors are packaged individually and all Commercial connectors are bulk packaged unless otherwise noted.

**TNC Connectors** (Continued)

**Specifications**

Characteristics	Single Crimp (MIL Type)	Category B O Crimp (MIL Type)	Commercial O Crimp & Hex Crimp 50 & 75 Ohm	Commercial PCB	Commercial Solder Jacks	Semi-Rigid	Solder Clamp
<b>Electrical</b>							
Impedance, Nom. (Ohms)	50	50	50	50	50	50	50
Working Voltage (Volts RMS)	500	500	500	500	500	335	500
Contact Resistance (Milliohms)	Inner: 1.5 Outer: 3	Inner: 1.5 Outer: 0.2	Inner: 2.0 Outer: 0.3	Inner: 6.0 Outer: 3.0	Inner: 2.75 Outer: 1.0	Inner: 1.5 Outer: 0.2	Inner: 1.5 Outer: 0.2
Initial Insulation Resistance (Megohms)	5000	5000	5000	5000	5000	5000	5000
Dielectric Withstanding Voltage (VAC)	1500	1500	1500	1500	1500	1500	1500
Corona Level at 70,000 ft. (Picocoulombs)	5 max. @ 375 VRMS	5 max. @ 375 VRMS	5 max. @ 375 VRMS	—	—	5 max. @ 375 VRMS	5 max. @ 375 VRMS
RF Leakage, Max. (dB)	—	60 @ 2-3 GHz	55 @ 2-3 GHz	—	—	60 @ 2-3 GHz	55 @ 2-3 GHz
RF Insertion Loss, Max. (dB)	—	0.18 @ 9 GHz	0.2 @ 3 GHz	—	—	0.06 @ 3-6 GHz	0.2 @ 3 GHz
Frequency Range (GHz)	0-4	0-11	0-7	0-4	0-4	0-15	0-11
VSWR in Frequency Range Max.	1.35	1.3	1.40	—	—	1.35	1.30 @ 4 GHz
<b>Mechanical</b>							
Force to Engage/ Couple, lbs. [N]	10/2 [44.5/8.9]	2/2 [8.9/8.9]	6/6 [26.7/26.7]	—	—	2 [.023]	2 [.023]
Coupling Nut Retention, Min. lbs. [N]	100 [444.8]	100 [444.8]	60 [266.9]	—	—	100 [444.8]	100 [444.8]
Cable Retention, lbs. [N]	60 [266.9] RG 58C/U	60 [266.9] RG 58C/U	60 [266.9] RG 58C/U	60 [266.9] (PCB Ret)	—	60 [266.9]	40 [178.0]
Durability (Cycles)	500	500	500	500	500	500	500
Jam Nut Mounting Torque, Max. lbs. [N•m]	25 [2.8]	25 [2.8]	25 [2.8]	25 [2.8]	25 [2.8]	25 [2.8]	25 [2.8]
<b>Environmental</b>							
Temperature Range, Operating (C°)	-65 to +85	-65 to +165 <sup>1</sup> -55 to +85 <sup>2</sup>	-55 to +85	-55 to +85	-65 to +165	-65 to +105	-65 to +165
Vibration	MIL-STD-202 Method 204 Cond. B	MIL-STD-202 Method 204 Cond. B	MIL-STD-202 Method 204 Cond. B	MIL-STD-202 Method 201A Cond. A	MIL-STD-202 Method 204 Cond. B	MIL-STD-202 Method 202 Cond. B	MIL-STD-202 Method 202 Cond. B
Physical Shock	MIL-STD-202 Method 213 Cond. G, (50 G's)	MIL-STD-202 Method 213 Cond. I, (100 G's)	MIL-STD-202 Method 213 Cond. I, (100 G's)	MIL-STD-202 Method 213 Cond. I, (100 G's)	MIL-STD-202 Method 213 Cond. I, (100 G's)	MIL-STD-202 Method 213 Cond. I	MIL-STD-202 Method 213 Cond. I
Thermal Shock	MIL-STD-202 Method 107	MIL-STD-202 Method 107 Cond. B	MIL-STD-202 Method 107 Cond. A	MIL-STD-202 Method 107	MIL-STD-202 Method 107	MIL-STD-202 Method 107	MIL-STD-202 Method 107
Moisture Resistance	MIL-STD-202 Method 106	MIL-STD-202 Method 106	MIL-STD-202 Method 106 Type II	MIL-STD-202 Method 106	MIL-STD-202 Method 106	MIL-STD-202 Method 106	MIL-STD-202 Method 106
Salt Spray	MIL-STD-202 Method 101 Cond. B	MIL-STD-202 Method 101 Cond. B	MIL-STD-202 Method 101 Cond. B	MIL-STD-202 Method 101 Cond. B	MIL-STD-202 Method 101 Cond. B	MIL-STD-202 Method 101 Cond. B	MIL-STD-202 Method 101 Cond. B
Product Specification	—	108-12001	108-12046	—	—	108-12032	—

<sup>1</sup>Assembled to cable with polytetrafluorethylene dielectric.  
<sup>2</sup>Assembled to cable with polyethylene dielectric.



**TNC Connectors** (Continued)

**Specifications** (Continued)

Characteristics	Single Crimp (MIL Type)	Category B O Crimp (MIL Type)	Commercial O Crimp & Hex Crimp 50 & 75 Ohm	Commercial PCB	Commercial Solder Jacks	Semi-Rigid	Solder Clamp
<b>Connector Material</b>							
Collar	Brass QQ-B-626	Brass QQ-B-626	Brass QQ-B-626	—	—	Brass QQ-B-626	Brass QQ-B-626
Outer Contact (Plug)	Phos. Bronze QQ-B-750 Beryl. Copper QQ-C-530	Phos. Bronze QQ-B-750 Beryl. Copper QQ-C-530	Brass MIL-C-21768	—	—	Brass QQ-B-626	Brass QQ-B-626
Outer Contact (Jack)	Brass QQ-B-626	Brass QQ-B-626	Zinc QQ-Z-363	Zinc QQ-Z-363	Zinc QQ-Z-363	Brass QQ-B-626	Brass QQ-B-626
Dielectric	PTFE MIL-P-19468	PTFE MIL-P-19468	Polyethylene Polypropylene Gen. Purpose	Polypropylene Gen. Purpose <sup>1</sup>	PTFE MIL-P-19468 Polyester PBT MIL-P-24519	PTFE MIL-P-19468	PTFE MIL-P-19468
Center Contact (Plug)	Brass QQ-B-626	Brass QQ-B-626	Brass QQ-B-626	—	—	Brass QQ-B-626	Brass QQ-B-626
Center Contact (Jack)	Beryl. Copper ASTM-B-643, QQ-C-530	Beryl. Copper ASTM-B-643, QQ-C-530	Beryl. Copper QQ-C-530	Phos. Bronze QQ-B-570	Phos. Bronze QQ-B-570	Beryl Copper QQ-C-530	Beryl Copper QQ-C-530
Gasket	Silicon Rubber QQ-R-765	Silicon Rubber QQ-R-765	Silicon Rubber QQ-R-765	—	—	Silicone Rubber QQ-R-765	Silicone Rubber QQ-R-765
Ferrule	Copper QQ-C-576	Copper QQ-C-576	Copper QQ-C-576	—	—	—	—
<b>Connector Primary Finishes<sup>2</sup></b>							
Collar	Silver QQ-S-365	Silver QQ-S-365	Bright Nickel QQ-N-290	—	—	Nickel QQ-N-290	Nickel QQ-N-290
Outer Contact (Plug & Jack)	Silver QQ-S-365	Bright Nickel QQ-N-290	Bright or Matte Nickel QQ-N-290	Bright Nickel QQ-N-290	Bright Nickel QQ-N-290	Nickel QQ-N-290	Nickel QQ-N-290
Center Contact (Plug & Jack)	Gold MIL-G-45204	Silver QQ-S-365	Tin Lead, ASTM-B-545 Silver, QQ-S-365 Gold, MIL-G-45204	Tin Lead, ASTM-B-545 Silver, QQ-S-365 Gold, MIL-G-45204	Tin Lead, ASTM-B-545 Silver, QQ-S-365 Gold, MIL-G-45204	Gold MIL-G-45204	Gold MIL-G-45204
Ferrule	Silver QQ-S-365	Gold MIL-G-45204	Tin Lead ASTM-B-5	—	—	—	—

<sup>1</sup>Several pc board connectors have an outer polyester PBT insulator per MIL-P-24519.

<sup>2</sup>If several finishes are listed, refer to individual catalog page(s) or customer drawings for exact specifications.

## TNC Connectors, 50 Ohm

### Plugs, Crimp

#### Hex Crimp and O Crimp

#### MIL Type O Crimp Weatherproof

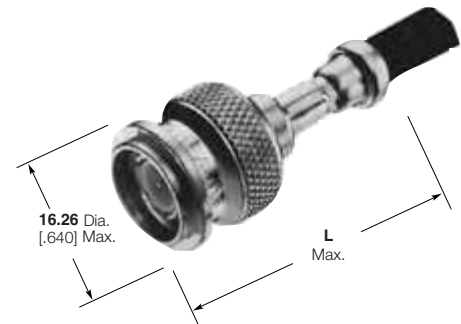
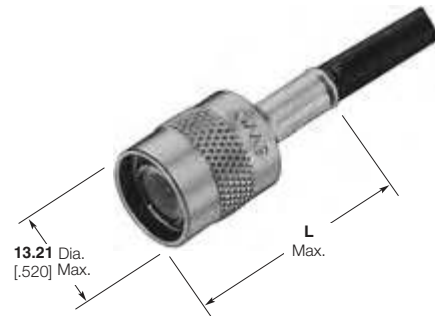

RG/U Cable	Termination Type	Center Contact Plating	Body Plating	Dielectric	Style	Comments	Dim. L	CERTI-CRIMP Hand Tool with Integral Die	Interchangeable Dies for PRO-CRIMPER Hand Tool 354940-1 or PRO-CRIMPER Adapter 679304-1	Part No.
174, 188, 188A, 316	Hex Crimp	Gold	Nickel	Polypropylene	Commercial	—	<b>31.24</b> 1.230	—	58436-3	<b>5222506-5</b>
179, 179A, 179B, 161, 187, 187A, BELDEN 9221	Hex Crimp	Gold	Nickel	Polypropylene	Commercial	—	<b>31.24</b> 1.230	—	58436-3	<b>5222506-6</b>
58, 58A, 58B, 58C	Hex Crimp	Gold	Nickel	Polypropylene	Commercial	—	<b>31.25</b> 1.230	—	58436-1 <sup>1</sup>	<b>5222506-1</b>
	O Crimp	Gold	Nickel	PTFE	MIL Type	Weatherproof	<b>34.93</b> 1.375	220045-2	—	<b>5225555-2</b>
142, 142A, 142B, 400	O Crimp	Gold	Nickel	PTFE	MIL Type	Weatherproof	<b>34.93</b> 1.375	220045-2	—	<b>5225555-6</b>
8, 8A, 213	O Crimp	Gold	Nickel	PTFE	MIL Type	Weatherproof	<b>50.8</b> 2.000	220015-1	—	<b>5225555-7</b>
9, 9A, 9B, 214	O Crimp	Gold	Nickel	PTFE	MIL Type	Weatherproof	<b>50.8</b> 2.000	220015-1	—	<b>5225555-8</b>

<sup>1</sup>Order Tyco Electronics PRO-CRIMPER Coaxial Hex Crimp Hand Tool assembly 58433-2, which includes dies 58436-1.

BELDEN is a trademark of Belden Wire and Cable Company.

**Note:** Part Numbers are RoHS compliant except: ♦ Indicates non-RoHS compliant.

**TNC Connectors, 50 Ohm** (Continued)

**Plugs for Semi Rigid-Cable**



**Solder Type**

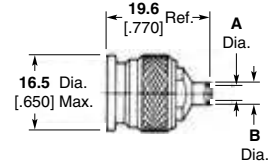

RG/U Cable	Termination Type	Center Contact Plating	Body Plating	Dielectric	Style	Comments	Dim. A	Dim. B	Interchangeable Dies for PRO-CRIMPER Hand Tool 354940-1 or PRO-CRIMPER Adapter 679304-1	Interchangeable Dies for Hand Tool 69710-1 & 626 Pneu. Head 318161-1	Part No.
405 Semi-Rigid/ 2.18 [.086]	Solder	Gold	Passivate	Solid PTFE	MIL Type	—	2.3 .089	3.0 .120	—	3	1057635-1
402 Semi-Rigid/ 3.66 [.141]	Crimp	Gold	Nickel	PTFE	Commercial	Weather proof	—	—	1	2	228179-3
RG 402/U .141 3.66 [.141]	Solder	Gold	Gold	Solid PTFE	MIL Type	—	3.7 .144	4.6 .180	—	3	1057631-1

<sup>1</sup>Hand Tool 59980-1, Requires (2) Crimping Dies 312253-1 and (1) Locator 312644-1.  
<sup>2</sup>Pneumatic Tool 58318-1, Requires (2) Crimping Dies 313720-1 and (1) Locator 312645-1.  
<sup>3</sup>Refer to Recommended Assembly Tools in Tool Section.

**Note:** Part Numbers are RoHS compliant except: ♦ Indicates non-RoHS compliant.

**TNC Connectors, 50 Ohm (Continued)**
**Right-Angle Plugs,  
Crimp**
**O Crimp**

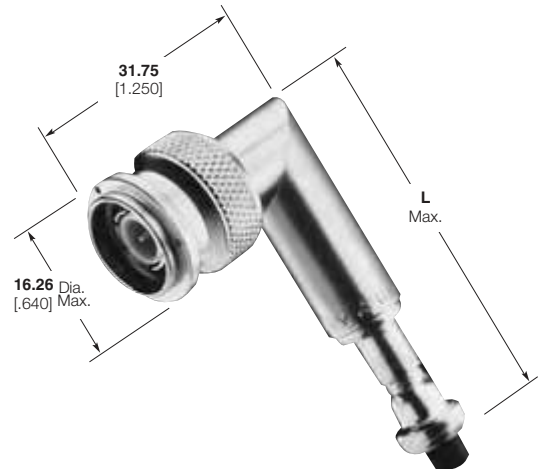
**MIL Type  
O Crimp  
Weatherproof**

RG/U Cable	Termination Type	Center Contact Plating	Body Plating	Dielectric	Style	Comments	Dim. L	CERTI-CRIMP Hand Tool with Integral Die	Interchangeable Dies for PRO-CRIMPER Hand Tool 354940-1 or PRO-CRIMPER Adapter 679304-1	Part No.
174, 174A, 188 188A, 316	O Crimp	Gold	Nickel	Polymethyl- pentene	Commercial	—	<b>38.23</b> 1.505	—	318450-2	<b>5414173-3</b>
58, 58A, 58B 58C	O Crimp	Gold	Nickel	PTFE	MIL Type	Weatherproof	<b>47.63</b> 1.875	220045-2	—	<b>5225559-2</b>
55, 55A, 55B 223	O Crimp	Gold	Nickel	Polymethyl- pentene	Commercial	—	<b>38.23</b> 1.505	—	220189-1	<b>5414173-6</b>
142, 142A, 142B 400	O Crimp	Gold	Silver	PTFE	MIL Type	Weatherproof	<b>47.63</b> 1.875	220045-2	—	<b>5225554-6</b>
8, 8A, 213	O Crimp	Gold	Nickel	PTFE	MIL Type	Weatherproof	<b>63.5</b> 2.500	220015-1	—	<b>5225559-8</b>
393, 225	O Crimp	Gold	Silver	PTFE	MIL Type	Weatherproof	<b>63.5</b> 2.500	220015-1	—	<b>1-5225554-1</b>
9, 9A, 9B, 214	O Crimp	Gold	Silver	PTFE	MIL Type	—	<b>59.52</b> 2.343	220015-1	—	<b>5225349-9</b>

**Note:** Part Numbers are RoHS compliant except: ♦ Indicates non-RoHS compliant.

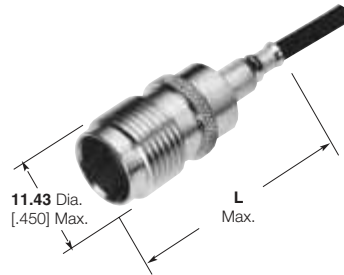
**TNC Connectors, 50 Ohm (Continued)**
**Jacks, Crimp**
**O Crimp**

**MIL Type  
O Crimp  
Weatherproof**

RG/U Cable	Termination Type	Center Contact Plating	Body Plating	Dielectric	Style	Comments	Dim. L	CERTI-CRIMP Hand Tool with Integral Die	Interchangeable Dies for PRO-CRIMPER Hand Tool 354940-1 or PRO-CRIMPER Adapter 679304-1	Part No.
174, 174A, 188 188A, 316	O Crimp	Gold	Nickel	Polymethyl- pentene	Commercial	—	<b>30.48</b> 1.200	—	318450-2	<b>5414171-3</b>
58, 58A, 58B 58C	O Crimp	Gold	Silver	PTFE	MIL Type	Weatherproof	<b>35.72</b> 1.406	220045-2*	—	<b>225551-2</b>
141, 141A, 303	O Crimp	Gold	Silver	PTFE	MIL Type	Weatherproof	<b>35.72</b> 1.406	220045-2*	—	<b>225551-5</b>
55, 55A, 55B 223	O Crimp	Gold	Nickel	Polymethyl- pentene	Commercial	—	<b>29.85</b> 1.175	—	220189-1	<b>414171-6</b>
142, 142A, 142B 400	O Crimp	Gold	Silver	PTFE	MIL Type	Weatherproof	<b>35.72</b> 1.406	220045-2*	—	<b>225551-6</b>

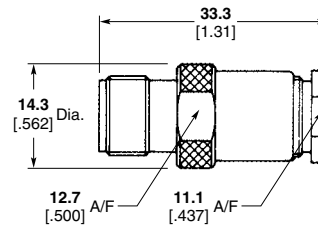
\*Battery, Pneumatic

**Jacks, Solder/Clamp**

RG/U Cable	Termination Type	Center Contact Plating	Body Plating	Dielectric	Style	Part No.
RG 58C/U, RG 141 A/U	Solder/Clamp	Gold	Silver	PTFE	MIL Type	<b>1312569-1</b>

**Note:** Part Numbers are RoHS compliant except: ♦ Indicates non-RoHS compliant.



**TNC Connectors, 50 Ohm (Continued)**

**Bulkhead Jacks, Crimp**

**Single Crimp**

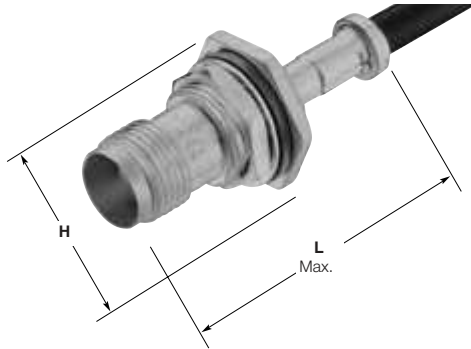

**O Crimp**

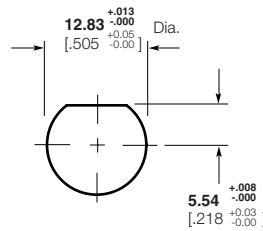
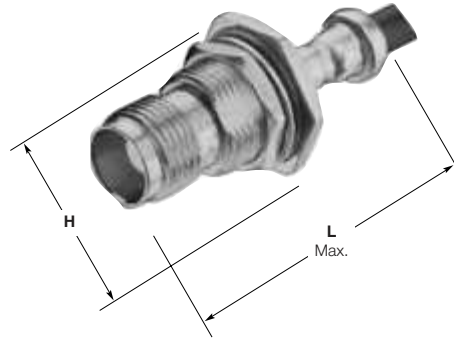

Maximum Panel Thickness Single Crimp **3.18** [.125];  
Dual Crimp **6.35** [.250]

**Recommended Panel Cutout**

H= **11/16** [.6875] max. across flats, **20.32** [.800] max. across points.

RG/U Cable	Termination Type	Center Contact Plating	Body Plating	Dielectric	Style	Comments	Dim. L	CERTI-CRIMP Hand Tool with Integral Die	Interchangeable Dies for PRO-CRIMPER Hand Tool 354940-1 or PRO-CRIMPER Adapter 679304-1	Part No.
174, 174A, 316 188, 188A	O Crimp	Gold	Nickel	Polymethyl-pentene	Commercial	—	<b>34.93</b> 1.375	—	318450-2	<b>5414168-3</b>
179, 179A, 179B 161, 187, 187A BELDEN 9221	Single Crimp	Gold	Nickel	PTFE	MIL Type	—	<b>38.1</b> 1.500	—	91910-1	<b>5331238</b>
RD 188, 316 Double Braid	O Crimp	Gold	Nickel	Polymethyl-pentene	Commercial	—	<b>34.93</b> 1.375	—	58539-1	<b>5414168-4</b>
58, 58A, 58B, 58C 141, 141A, 303	O Crimp	Gold	Nickel	Polymethyl-pentene	Commercial	—	<b>34.93</b> 1.375	—	220189-1	<b>5414168-1</b>
223 55, 55A, 55B	O Crimp	Gold	Nickel	Polymethyl-pentene	Commercial	—	<b>34.93</b> 1.375	—	220189-1	<b>5414168-6</b>
142, 142A 142B, 400	O Crimp	Gold	Nickel	Polymethyl-pentene	Commercial	—	<b>34.93</b> 1.375	—	220189-1	<b>5414168-5</b>
	O Crimp	Gold	Nickel	PTFE	MIL Type	Weatherproof	<b>38.1</b> 1.500	220045-2	—	<b>5225557-6</b>

BELDEN is a trademark of Belden Wire and Cable Company.

**Note:** Part Numbers are RoHS compliant except: ♦ Indicates non-RoHS compliant.

**TNC Connectors, 50 Ohm (Continued)**

**Bulkhead Jacks for  
Semi-Rigid Cable,  
Rear Mount**

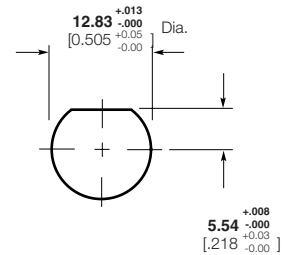
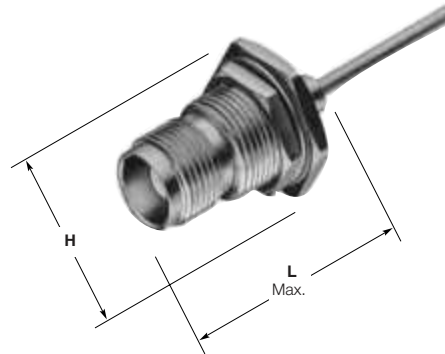

Maximum Panel Thickness **6.35** [.250]

**Recommended  
Panel Cutout**

H = **17.45** [.687] max. across flats, **20.32** [.800] max. across points.

RG/U Cable	Termination Type	Center Contact Plating	Body Plating	Dielectric	Style	Dim. L	Part No.
402 Semi-Rigid/ <b>3.66</b> [.141]*	Crimp	Gold	Nickel	PTFE	MIL Type	<b>25.4</b> 1.000	<b>228502-1</b>

\*Tooling—Hand Tool 59980-1, Requires (2) Crimping Dies 312253-1 and (1) Locator 220220-2.

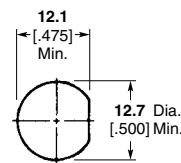

**Recommended  
Panel Cutout**

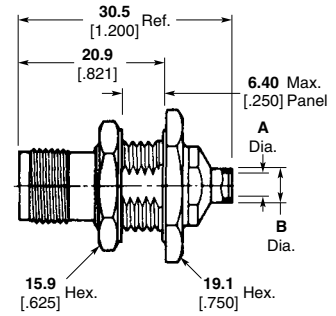

RG/U Cable	Termination Type	Center Contact Plating	Body Plating	Dielectric	Style	Dim. A	Dim. B	Part No.
RG 402/U <b>3.66</b> [.141]	Solder	Gold	Pass. Stainless Steel	Solid PTFE	MIL Type	<b>3.7</b> .144	<b>4.6</b> .180	<b>1057676-1</b>
RG 405/U <b>2.16</b> [.085]	Solder	Gold	Pass. Stainless Steel	Solid PTFE	MIL Type	<b>2.3</b> .089	<b>3.0</b> .120	<b>1057679-1</b>

**Note:** Part Numbers are RoHS compliant except: ♦ Indicates non-RoHS compliant.

**TNC Connectors, 50 Ohm (Continued)**

**Panel Jacks, Crimp**

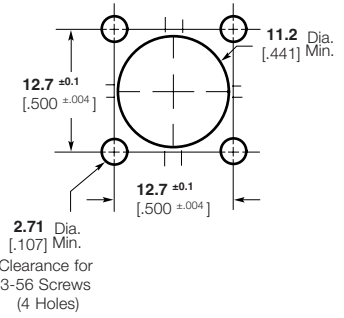
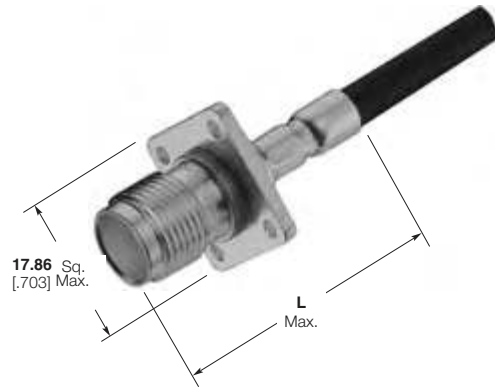

**Recommended  
Panel Cutout**

RG/U Cable	Termination Type	Center Contact Plating	Body Plating	Dielectric	Style	Dim. L	CERTI-CRIMP Hand Tool With Integral Die	Part No.
58, 58A, 58B, 58C	Crimp	Gold	Silver	PTFE	MIL Type	34.93 1.375	220045-2	225348-2

**Panel Jacks for  
Semi-Rigid Cable**

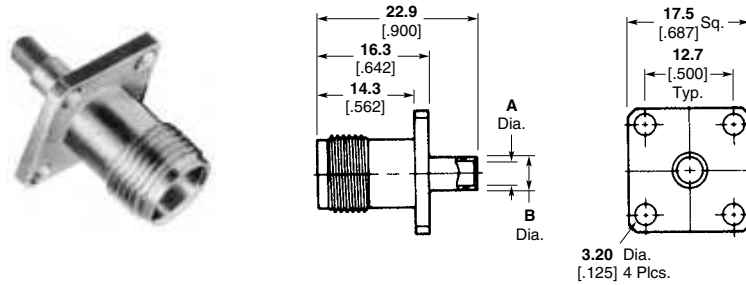

RG/U Cable	Termination Type	Center Contact Plating	Body Plating	Dielectric	Style	Dim. A	Dim. B	Part No.
RG 402/U 3.66 [.141]	Solder	Gold	Gold	PTFE	MIL Type	3.7 .144 Min.	4.6 .180	1057697-1
RG 405/U 2.16 [.085]	Solder	Gold	Gold	PTFE	MIL Type	2.3 .089 Min.	3.0 .120	1057699-1

**Note:** Part Numbers are RoHS compliant except: ♦ Indicates non-RoHS compliant.

**TNC Connectors, 50 Ohm (Continued)**

**Right-Angle PC Board/  
Panel Mount Jacks**

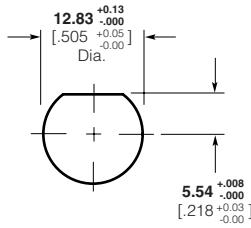

Maximum Panel Thickness **6.1** [.240]

**Recommended  
Panel Cutout**

**VALOX Body**

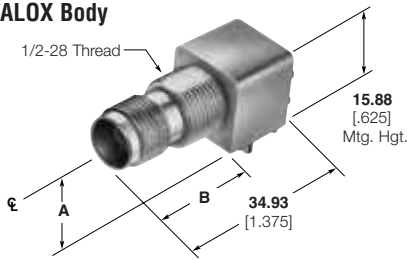

**Metal Body**

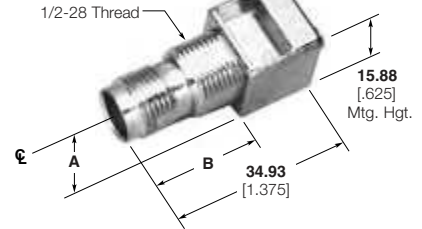

Body Material	Ω	Center Contact Plating	Dimensions		Part Numbers
			A	B	
VALOX, White	50	Gold	<b>8.56</b> .337	<b>21.21</b> .835	<b>5227818-1</b>
Metal	50	Gold	<b>8.26</b> .325	<b>20.83</b> .820	<b>5227839-1</b>

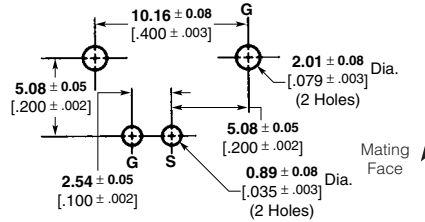

(Top View)

**Recommended PC Board Layout**

**Vertical PC Board/  
Panel Mount Jacks**

\*2-56 Self-Tapping Screws:  
For 1.57 [3/32] or greater panel thickness  
Part No. **221108-2**  
For less than 1.57 [3/32] panel thickness  
Part No. **221108-4**

**Lockwasher and Jam Nut**



Part No.  
**1-329632-2**



Part No.  
**1-329631-2**

**VALOX Body**

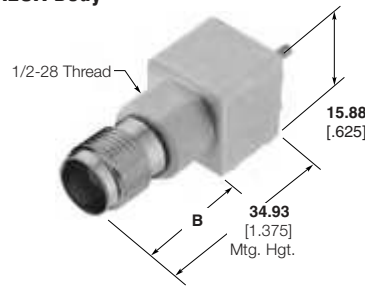

Body Material	Center Contact Plating	Dimension B	Part Number
VALOX, White	Gold	<b>21.21</b> .835	<b>5227820-1</b>

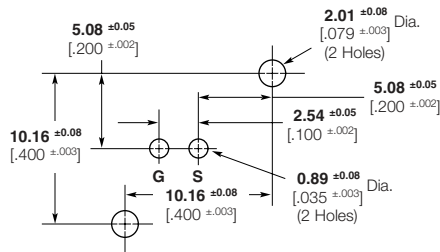

(Top View)

**Recommended PC Board Layout**

VALOX is a trademark of General Electric Company.

**Note:** Part Numbers are RoHS compliant except: ♦ Indicates non-RoHS compliant.

**TNC Connectors, 50 Ohm (Continued)**

**Right-Angle PC Board/  
Mount Jacks**

**Plating**

**Body** — Nickel

**Center Contact** — Gold

**Dielectric** — PTFE



**Part No. 5413933-1**

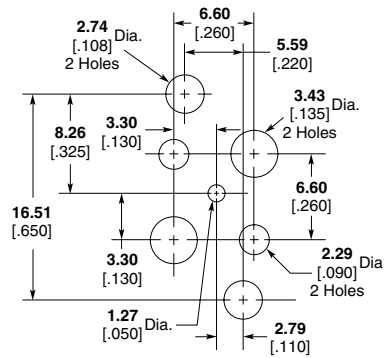

**Recommended PC Board Cutout**

**Bulkhead Solder Jacks**

**Insulation Bushing**

**Material** — Nylon

**Part No. 227223-1**

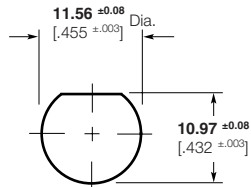
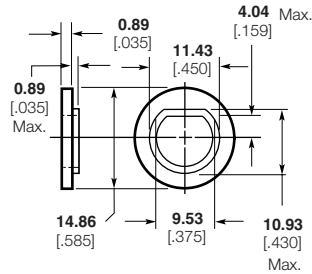

**Recommended Panel Cutout  
(Bushing)**

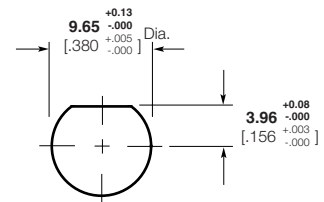
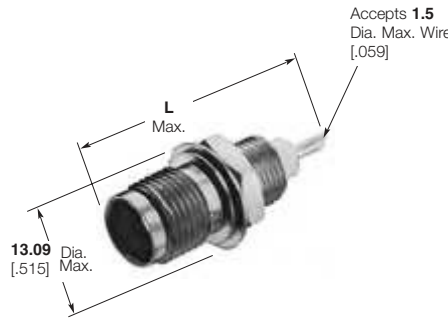

**Recommended  
Panel Cutout  
(Jack)**

Panel Thickness Refer to chart below.

Body Plating	Center Contact Plating	Dielectric	Dim. L	Panel Thickness	Part Number
Nickel	Gold	VALOX	33.33 1.312	1.17-6.35 .046-.250	5227764-2

VALOX is a trademark of General Electric Company.

**Note:** Part Numbers are RoHS compliant except: ♦ Indicates non-RoHS compliant.



**TNC Connectors, 50 Ohm (Continued)**

**Panel Mount Jack Receptacles**

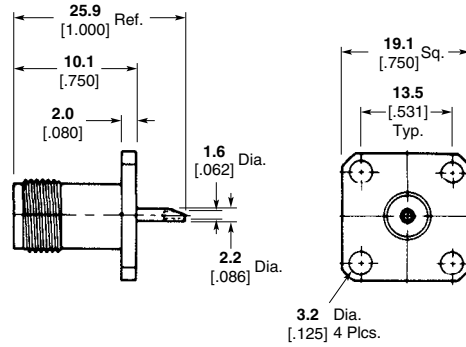

Shell	Part No.
Nickel Plated Brass	1057775-1 <sup>1</sup>

<sup>1</sup>Captured Center Contact

**Flange Mount Receptacles**

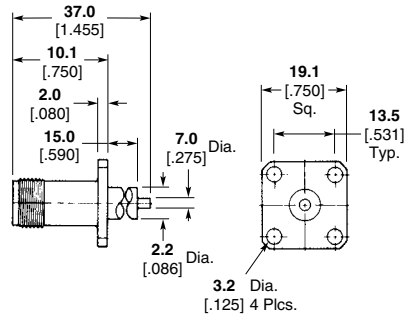

Shell	Part No.
Nickel Plated Brass	1057780-11

<sup>1</sup>Captured Center Contact

**Jack-Jack Adapter**

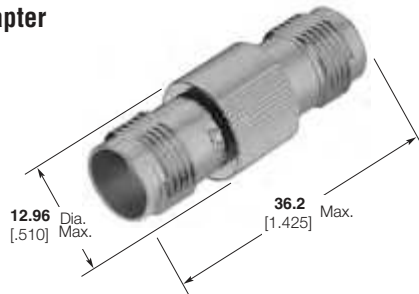

Center Contact Plating	Body Plating	Dielectric	Part No.
Gold	Nickel	Polypropylene	5221325-1

**Bulkhead Jack-Jack Adapter**

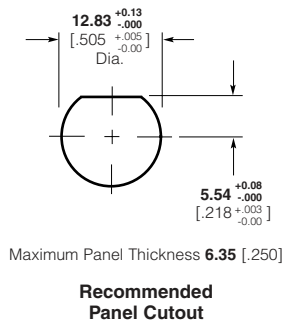

Center Contact Plating	Body Plating	Dielectric	Part No.
Gold	Nickel	Acetal	221500-1

**Note:** Part Numbers are RoHS compliant except: ♦ Indicates non-RoHS compliant.

**TNC Connectors, 75 Ohm**

**Plugs, Crimp**

These connectors have been designed for optimum performance and have a true 75 ohm impedance the complete length of the connector. The crimp die tooling listed below is different from the equivalent 50 ohm connectors.

**Hex Crimp and O Crimp**

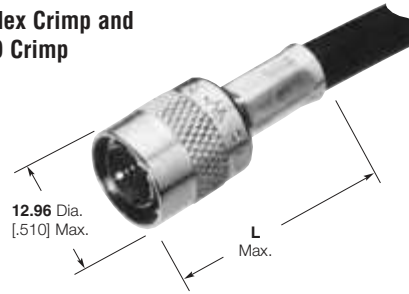

RG/U Cable	Termination Type	Center Contact Plating	Body Plating	Dielectric	Style	Dim. L	Interchangeable Dies for PRO-CRIMPER Hand Tool 354940-1 or PRO-CRIMPER Adapter 679304-1	Part No.
179, 179A, 179B, 187, 187A, BELDEN 9221	O Crimp	Gold	Nickel	Polymethyl-pentene	Commercial	27.79 1.094	318451-2	5221506-3
AT&T 735A	O Crimp	Gold	Nickel	Polymethyl-pentene	Commercial	29.46 1.160	58174-1	5221506-5
302 BELDEN 88241 89269 Hi-Temp 62A Times PL62, BERK-TEK BTDC-59, BTDC-62	Hex Crimp	Gold	Nickel	Polymethyl-pentene	Commercial	31.75 1.250	58425-1	5413591-1
BELDEN 8281 9141, 9231	O Crimp	Gold	Nickel	Polymethyl-pentene	Commercial	32.9 1.295	58538-1	5221506-2

**Bulkhead Jack, Crimp**

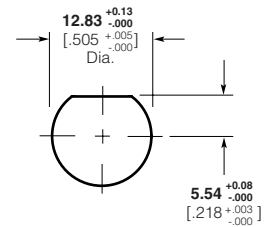

Maximum Panel Thickness 6.35 [0.250]

**Recommended Panel Cutout**

RG/U Cable	Termination Type	Center Contact Plating	Body Plating	Dielectric	Style	Dim. H	Tooling	Part No.
210, 62, 62A, 62B, 59, 59A, 59B, BELDEN 9291, 9209, 9169, 89269	O Crimp	Gold	Nickel	Polymethyl-pentene	Commercial	11/16 across flats, 20.32 .800 max. across points	Use Hand Tool 354940-1 with Die Set 58536-1	221509-1

AT&T is a trademark of AT&T Corporation.

BELDEN is a trademark of Belden Wire and Cable Company.

BERK-TEK is a trademark of Nexans, Inc.

**Note:** Part Numbers are RoHS compliant except: ♦ Indicates non-RoHS compliant.

**TNC Connectors, 75 Ohm (Continued)**

**Right-Angle PC Board/  
Panel Mount Jacks**

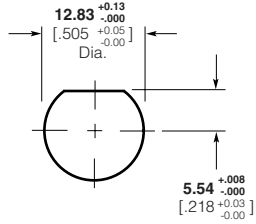

Maximum Panel Thickness **6.1** [.240]

**Recommended  
Panel Cutout**

**Metal Body**

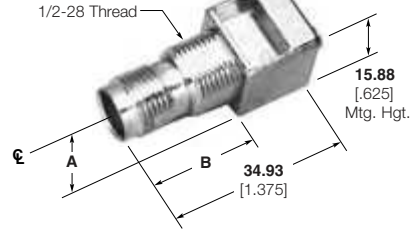

Body Material	Ω	Center Contact Plating	Dimensions		Part Numbers	
			A	B	Without Mounting Posts	With Mounting Posts
Metal	75	Gold	8.26 .325	20.83 .820	—	5413506-1

**Bulkhead Jack-Jack  
Adapter**



Center Contact Plating	Body Plating	Dielectric	Part No.
Gold	Nickel	Polymethylpentene	414396-1

**Note:** Part Numbers are RoHS compliant except: ♦ Indicates non-RoHS compliant.

## BNC Connectors (50 ohm/75 ohm)

### Product Facts

- Bayonet lock coupling for quick connect/disconnect
- Various connectors available in 50 and 75 ohm versions
- Fully intermateable with comparable BNC UG/U connectors
- Full range of Hex Crimp and O Crimp Products for common coaxial cables.
- Low VSWR
- Single crimp connectors offer one crimping operation for fast application
- Twist-on connectors require no special tooling for application to the cable
- Field serviceable (Category A) connectors qualified to MIL-C-39012
- Field replaceable (Category C) plugs with captivated center contact
- Field replaceable plugs can be terminated with industry standard tooling
- Tarnish resistant Nickel finish available
- Choice of different dielectrics
- Listed under the Component Program of Underwriters Laboratories Inc., File No. E81956 
- PC Board soldered connectors are recognized under the Component Program of Underwriters Laboratories Inc., File No. E81956 
- Certified by Canadian Standards Association File No. LR 7189 

### Between Series Adapters

For BNC Between Series Adapters, see pages 251-260.



The Tyco Electronics BNC RF connector family with bayonet locking coupling provides highly reliable, quick connect/disconnect coaxial connections. Exclusive single and O crimp terminations allow positive insulation grip and require no soldering, providing terminations at a very low overall applied cost.

Available in both 50 and 75 ohm versions, these con-

nectors feature numerous styles including cable plugs and jacks, adapters and printed circuit board connectors. In addition to a variety of crimp type terminations, connectors are furnished in field replaceable and twist-on styles. These connectors accept a wide range of coaxial cables and are intermateable with industry standard connectors designed to MIL-C-39012 specifications.

Tyco Electronics can also supply low cost alternatives with an extensive commercial type product line. A lower cost consumer series product offers the capability to supply center contacts in strip form and allow for automated center contact crimp technology. All connectors are designed around the mil-specifications, but utilize low-cost materials, offering comparable mechanical and electrical performance.

### Related Product Data

#### Product Specifications —

- 108-1275 — BNC Ohm Terminators
- 108-12020 — BNC O Crimp Connectors
- 108-12044 — BNC Commercial Hex Crimp
- 108-12047 — BNC Commercial and Hex Crimp Connectors
- 108-12074 — BNC Solder Jacks
- 108-12075 — BNC Connectors (Category A)
- 108-12078 — BNC Commercial PCB Panel-Mount Jacks

- 108-12002 — BNC Commercial T Adapter
- 108-12095 — BNC Commercial 75 Ohm Connectors
- 108-12096 — BNC Commercial Feed-Thru and Bulkhead Adapters
- 108-12079 — BNC Commercial 50 Ohm Solder Jacks
- 108-12103 — BNC Commercial PCB Press Fit Jacks

#### Application Specifications —

- 114-12001 — BNC Commercial PCB Jack Press Fit

#### Performance Specifications —

Page 45

#### Material Specifications — Page 46

#### Tooling — Pages 266-268

**Military Category** — All MIL type O crimp connectors are Category B Type (Tyco Electronics Crimp Tooling), unless otherwise noted.

**Packaging** — All MIL Type connectors are packaged individually, all O crimp connectors are bulk packaged and all Hex crimp connectors are individually packaged unless otherwise noted.

## BNC Connectors (50 ohm/75 ohm) Performance Specifications

Characteristics	Single Crimp (MIL Type)	Category B O Crimp (MIL Type)	Straight Solder Clamp	Right-Angle Solder Clamp	Commercial O Crimp & Hex Crimp 50 Ohms	Commercial O Crimp & Hex Crimp 75 Ohms	Commercial PC Board 50 & 75 Ohms	Commercial Solder 50 Ohm Jacks
<b>Electrical</b>								
Impedance, Nom. (Ohms)	50	50	50	50	50	75	50 & 75	50 & 75
Working Voltage (Volts RMS)	500	500	500	500	500	500	500	500
Contact Resistance (Milliohms)	Inner: 1.5 Outer: 0.3	Inner: 1.5 Outer: 0.2	Inner: 1.5 Outer: .20	Inner: 1.5 Outer: .20	Inner: 2.0 Outer: 1.0	Inner: 2.0 Outer: 2.0	Inner: 6/1.5 Outer: 3/0.2	Inner: 2.75 Outer: 1.0
Initial Insulation Resistance (Megohms)	5000	5000	5000	5000	5000	5000	5000	5000
Dielectric Withstanding Voltage (VAC)	1500	1500	1500	1500	1500	1500	1500	1500
Corona Level at 70,000 ft. (Volts, RMS)	375	375	375	375	375	375	—	375
RF Leakage, Max. (dB)	—	-55 at 2-3 GHz	-55 at 2-3 GHz	-55 at 2-3 GHz	-55 at 2-3 GHz	-55 at 1-2 GHz	—	—
RF Insertion Loss, Max. (dB)	—	0.2 at 3 GHz	0.2 at 3 GHz	0.3 at 3 GHz	0.2 at 3 GHz	0.15 at 2 GHz	—	—
Frequency Range (GHz)	0-2.5	0-4	0-4	0-4	0-4	0-2	0-4 and 0-2	0-4
VSWR in Frequency Range Max.	1.35	1.30	1.30	1.35	1.30	1.30	—	—
<b>Mechanical</b>								
Force to Engage (lbs. [N])/couple, (in-lbs. [N·m]) max.	13.3/11.12 [3/2.5]	13.3/11.12 [3/2.5]	13.3/.028 [3/2.5]	13.3/.028 [3/2.5]	26.7/26.69 [6/6.0]	26.7/26.69 [6/6.0]	—	—
Coupling Nut Retention, Min. N [lbs.]	444.8 [100]	444.8 [100]	444.8 [100]	444.8 [100]	266.9 [60]	266.9 [60]	—	—
Cable Retention, N [lbs.]	266.9 [60] (RG58C/U)	266.9 [60] (RG58C/U)	177.9 [40] (RG58C/U)	177.9 [40] (RG58C/U)	266.9 [60] (RG58C/U)	266.9 [60] (RG58C/U)	266.9 [60] (PCB Ret)	—
Durability (Cycles)	500	500	500	500	500	500	500	500
Jam Nut Mounting Torque, Max. [N·m] (in. lbs.)	25 [2.8]	25 [2.8]	25 [2.8]	—	25 [2.8]	25 [2.8]	25 <sup>3</sup> /12 <sup>4</sup> [2.8/1.4]	25 [2.8]
<b>Environmental</b>								
Temperature Range, Operating (C°)	-65 to +85	-65 to +165 <sup>1</sup> -55 to +85 <sup>2</sup>	-65 to +165	-65 to +165	-55 to +85	-55 to +85	-55 to +85	-65 to +165
Vibration	MIL-STD-202 Method 204 Cond. B	MIL-STD-202 Method 204 Cond. B	MIL-STD-202 Method 204 Cond. B	MIL-STD-202 Method 204 Cond. B	MIL-STD-1344 Method 2005 Cond. III	MIL-STD-202 Method 204 Cond. B	MIL-STD-202 Method 201A	MIL-STD-202 Method 204 Cond. B
Physical Shock	MIL-STD-202 Method 213 Cond. G, 50 G's	MIL-STD-202 Method 213 Cond. G, 50 G's	MIL-STD-202 Method 213 Cond. G	MIL-STD-202 Method 213 Cond. G	MIL-STD-1344 Method 2004 Cond. G, 100 G's	MIL-STD-202 Method 213 Cond. I, 100 G's	MIL-STD-202 Method 213 Cond. I or A, 50 G's	MIL-STD-202 Method 213 Cond. I, 100 G's
Thermal Shock	MIL-STD-202 Method 107	MIL-STD-202 Method 107	MIL-STD-202 Method 107	MIL-STD-202 Method 107	MIL-STD-1344 Method 1003 Cond. A	MIL-STD-202 Method 107	MIL-STD-202 Method 107	MIL-STD-202 Method 107
Moisture Resistance	MIL-STD-202 Method 106	MIL-STD-202 Method 106	MIL-STD-202 Method 106	MIL-STD-202 Method 106	MIL-STD-1344 Method 1002 Type II	MIL-STD-202 Method 106	MIL-STD-202 Method 106	MIL-STD-202 Method 106
Salt Spray	MIL-STD-202 Method 101 Cond. B	MIL-STD-202 Method 101 Cond. B	MIL-STD-202 Method 101 Cond. B	MIL-STD-202 Method 101 Cond. B	MIL-STD-1344 Method 1001 Cond. B	MIL-STD-202 Method 101 Cond. B	MIL-STD-202 Method 101 Cond. B	MIL-STD-202 Method 101 Cond. B
Product Specification	108-12002	108-12020	—	—	108-12044 108-12047	108-12095	108-12078	108-12079

<sup>1</sup>Assembled to cable with polytetrafluorethylene dielectric.

<sup>2</sup>Assembled to cable with polyethylene dielectric.

<sup>3</sup>For Metal Threads

<sup>4</sup>For Polyester Threads

**BNC Connectors (50 ohm/75 ohm) Performance Specifications (Continued)**

Connector Component	Single Crimp (MIL Type)	Category B & C O Crimp (MIL Type)	Straight Solder Clamp	Right-Angle Solder Clamp	Commercial O Crimp Hex Crimp & Terminators	Commercial PCB Solder	Commercial PCB Press Fit	Commercial Solder Ohm Jacks	Adapters
<b>Connector Material</b>									
Collar	Brass QQ-B-626	Brass QQ-B-626	Brass	Brass	Brass QQ-B-626 Zinc QQ-Z-363	—	—	—	Brass QQ-B-626
Outer Contact (Plug)	Brass QQ-B-626 Beryl. Copper QQ-C-530	Phos. Bronze QQ-B-750	Brass	Brass	Brass MIL-C-21768	—	—	—	Brass QQ-B-626 Beryl. Copper QQ-C-530
Shell (Jack)	Brass QQ-B-626	Brass QQ-B-626	Brass	—	Zinc QQ-Z-363	Zinc QQ-Z-363	Zinc Zinc QQ-Z-363	QQ-Z-363 Brass QQ-B-626	Brass QQ-B-626
Dielectric	PTFE MIL-P-19468 Polypropylene Gen. Purpose	PTFE MIL-P-19468	PTFE	PTFE	Polyethylene Polypropylene Polymethylpentene Gen. Purpose	Polymethylpentene Gen. Purpose <sup>1</sup>	PTFE MIL-P-19468	PTFE MIL-P-19468 Polyester PBT MIL-P-24519	PTFE MIL-P-19468 Polypropylene, Gen. Purpose
Center Contact (Plug)	Brass QQ-B-626	Brass QQ-B-626	Brass	Brass	Brass QQ-B-626	—	—	—	Brass QQ-B-626 Beryl. Copper QQ-C-530
Center Contact (Jack)	Beryl. Copper ASTM-B-643 QQ-C-530	Beryl. Copper ASTM-B-643 QQ-C-530	Beryl. Copper	Beryl. Copper	Beryl. Copper QQ-C-530	Phos. Bronze QQ-B-750	Beryl. Copper QQ-C-530	Phos. Bronze QQ-B-570 Beryl. Copper QQ-C-530	Phos. Bronze QQ-B-570 Beryl. Copper QQ-C-530
Gasket	Silicon Rubber QQ-R-765	Silicon Rubber QQ-R-765	Silicon Rubber	Silicon Rubber	Silicon Rubber QQ-R-765	—	—	—	Silicon Rubber QQ-R-765
Ferrule	Copper QQ-C-576	Copper QQ-C-576	—	—	Copper QQ-C-576	—	—	—	—
<b>Connector Primary Finishes<sup>2</sup></b>									
Collar	Silver QQ-S-365 Bright Nickel QQ-N-290	Silver QQ-S-365 Bright Nickel QQ-N-290	Silver/ Bright Nickel	Silver/ Bright Nickel	Bright Nickel QQ-N-290	—	—	—	Silver QQ-S-365 Bright Nickel QQ-N-290
Outer Contacts (Plug & Jack)	QQ-S-365 Gold	Silver QQ-S-365 Bright Nickel QQ-N-290	Silver/ Bright Nickel	Silver/ Bright Nickel	Bright or Matte Nickel QQ-N-290	Bright Nickel QQ-N-290	Bright Nickel QQ-N-290	Bright Nickel QQ-N-290	Silver QQ-S-365 Bright Nickel QQ-N-290
Center Contacts (Plug & Jack)	MIL-G-45204 Silver	Gold MIL-G-45204	Gold	Gold	Tin Lead ASTM-B-545 Silver, QQ-S-365 Gold, MIL-G-45204	Tin Lead ASTM-B-545 Silver, QQ-S-365 Gold, MIL-G-45204	Gold MIL-B-45204	Tin Lead ASTM-B-545 Silver, QQ-S-365 Gold, MIL-G-45204	Silver QQ-S-365 Gold MIL-G-45204
Ferrule <sup>3</sup>	QQ-S-365	Silver QQ-S-365 Tin Lead ASTM-B-545	—	—	Tin Lead ASTM-B-545	—	—	—	—

<sup>1</sup>Several pc board connectors have an outer polyester PBT insulator per MIL-P-24519.

<sup>2</sup>If more than one finish is listed, refer to individual catalog page(s) or customer drawings for exact specification.

<sup>3</sup>Ferrules with tin-lead finish are used with nickel plated outer contacts.

## BNC Connectors, 50 Ohm

### Plugs, Crimp

#### Single Crimp

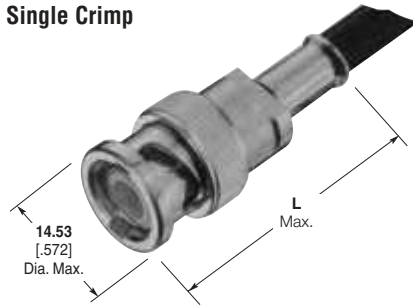

#### Hex and O Crimp

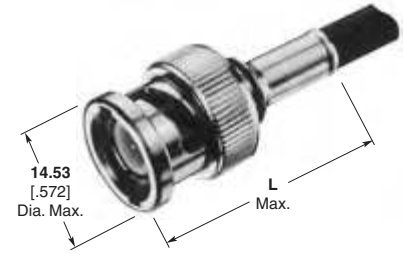

RG/U Cable	Termination Type	Body Plating	Dielectric	Style	Dim. L	CERTI-CRIMP Hand Tool with Integral Die	Interchangeable Dies for PRO-CRIMPER Hand Tool 354940-1 or PRO-CRIMPER Adapter 679304-1	Interchangeable Dies for Hand Tool 69710-1 & 626 Pneu. Head 318161-1	Part No.
178, 178A, 178B, 196, 196A	Single Crimp	Silver	PTFE	MIL Type	<b>33.33</b> 1.312	69245-4	—	69471	<b>5330876</b>
174, 188, 188A, 316	Hex Crimp	Nickel	Polyethylene	Commercial	<b>33.53</b> 1.320	—	58436-3	—	<b>2-5221128-1</b>
	O Crimp	Nickel	Polyethylene	Commercial	<b>27.69</b> 1.090	220009-5	318450-2	220217-3	<b>1-5227079-6</b>
	O Crimp	Nickel	PTFE	MIL Type	<b>30.18</b> 1.188	—	1424050-1	220026-1	<b>5225395-7</b>
	Single Crimp	Silver	PTFE	MIL Type	<b>33.33</b> 1.312	69245-2	—	69422	<b>2-5330061-1</b>
179, 179A, 179B, 161, 187, 187A, BELDEN 9221	Hex Crimp	Nickel	Polyethylene	Commercial	<b>33.53</b> 1.320	—	58436-3	—	<b>2-5221128-3</b>
	O Crimp	Nickel	Polyethylene	Commercial	<b>27.69</b> 1.090	—	1424050-1	220217-3	<b>2-5227079-2</b>
	O Crimp	Nickel	PTFE	MIL Type	<b>30.18</b> 1.188	—	—	220026-1	<b>5225395-8</b>
	Single Crimp	Silver	PTFE	MIL Type	<b>33.33</b> 1.312	—	91910-1	69408	<b>2-5329446-1</b>
RD 316, 188, Double Braid	O Crimp	Nickel	Polyethylene	Commercial	<b>27.69</b> 1.090	69477-4	58539-1	—	<b>8-5227079-2</b>
BELDEN 8219	Hex Crimp	Nickel	Polyethylene	Commercial	<b>33.53</b> 1.320	—	58436-1 <sup>2</sup>	—	<b>2-5221128-7</b>
	O Crimp	Nickel	Polyethylene	Commercial	<b>27.69</b> 1.090	220187-1	58435-1 <sup>1</sup>	220217-1	<b>6-5227079-7<sup>3</sup></b>
BELDEN 9907, 89907 COMM/SCOPE 2104	O Crimp	Nickel	Polyethylene	Commercial	<b>27.69</b> 1.090	220187-1	318452-2	220217-1	<b>6-5227079-8<sup>4</sup></b>
BELDEN 8218	O Crimp	Nickel	Polyethylene	Commercial	<b>27.69</b> 1.090	69477-4	58539-1	58376-1	<b>1-5227079-9</b>
	O Crimp	Nickel	PTFE	MIL Type	<b>30.18</b> 1.188	—	91904-1	69669-2	<b>1-5225395-0</b>

<sup>1</sup>Order Tyco Electronics PRO-CRIMPER Coaxial "O" Crimp Hand Tool assembly 58433-1, which includes dies 58435-1.

<sup>2</sup>Order Tyco Electronics PRO-CRIMPER Coaxial Hex Crimp Hand Tool assembly 58433-2, which includes dies 58436-1.

<sup>3</sup>For use with BELDEN 9907 cable, COMM/SCOPE 3104 cable, and BELDEN 8219 cable only.

<sup>4</sup>For use with BELDEN 89907 cable, and COMM/SCOPE 2104 cable only.

BELDEN is a trademark of Belden Wire and Cable Company.

COMM/SCOPE is a trademark of Commscope, Inc.

**Note:** Part Numbers are RoHS compliant except: ♦ Indicates non-RoHS compliant.

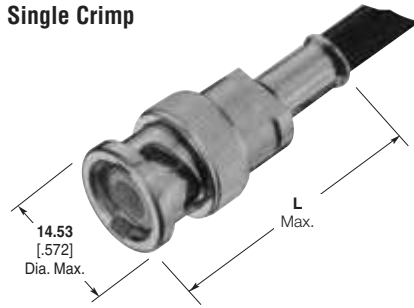
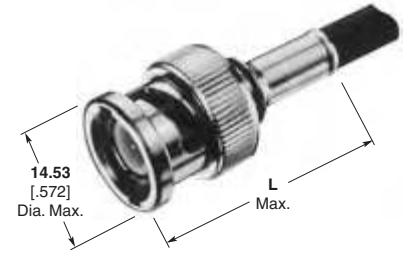

**BNC Connectors, 50 Ohm (Continued)**
**Plugs, Crimp (Continued)**
**Single Crimp**

**Hex and O Crimp**

RG/U Cable	Termination Type	Body Plating	Dielectric	Style	Dim. L	CERTI-CRIMP Hand Tool with Integral Die	Interchangeable Dies for PRO-CRIMPER Hand Tool 354940-1 or PRO-CRIMPER Adapter 679304-1	Interchangeable Dies for Hand Tool 69710-1 & 626 Pneu. Head 318161-1	Part No.
58, 58A, 58B, 58C	Hex Crimp	Nickel	Polyethylene	Commercial	<b>33.53</b> 1.320	—	58436-12	—	<b>5221128-1<sup>3</sup></b>
	O Crimp	Nickel	Polyethylene	Commercial	<b>27.69</b> 1.090	220187-1	58435-11	220217-1	<b>5227079-5</b>
	O Crimp	Nickel	PTFE	MIL Type	<b>33.74</b> 1.328	69478-1	220189-3	69727	<b>5225395-1</b>
	Single Crimp	Silver	PTFE	MIL Type	<b>33.33</b> 1.312	—	91904-4	69223-1	<b>2-5329444-1</b>
BELDEN 88240, BERK-TEK BTDC-58, COMM/SCOPE 2135	Hex Crimp	Nickel	Polyethylene	Commercial	<b>33.53</b> 1.320	—	58436-12	—	<b>1-5221128-0</b>
	O Crimp	Nickel	Polyethylene	Commercial	<b>33.33</b> 1.312	220187-1	58435-11	220217-1	<b>4-5227079-3</b>
	O Crimp	Nickel	PTFE	MIL Type	<b>33.33</b> 1.312	69478-1	220189-3	69727	<b>4-5225395-2</b>
223, 55, 55A, 55B	O Crimp	Nickel	Polyethylene	Commercial	<b>27.69</b> 1.280	220187-1	58435-11	220217-1	<b>5227079-6</b>
	O Crimp	Nickel	PTFE	MIL Type	<b>43.64</b> 1.718	69478-1	220189-3	69727	<b>5225395-3</b>
	Single Crimp	Silver	PTFE	MIL Type	<b>33.33</b> 1.312	—	91904-3	69424	<b>2-5329444-2</b>
142, 142A, 142B, 400	O Crimp	Nickel	Polyethylene	Commercial	<b>27.69</b> 1.090	220187-1	58435-11	220217-1	<b>6-5227079-1</b>
	O Crimp	Nickel	PTFE	MIL Type	<b>30.18</b> 1.188	69478-1	220189-3	69727	<b>5225395-6</b>
	Single Crimp	Silver	PTFE	MIL Type	<b>33.33</b> 1.312	69331-1	—	69429-1	<b>2-5330358-2</b>

Consult Tyco Electronics for recommended crimp tooling.

<sup>1</sup>Order Tyco Electronics PRO-CRIMPER Coaxial "O" Crimp Hand Tool assembly 58433-1, which includes dies 58435-1.

<sup>2</sup>Order Tyco Electronics PRO-CRIMPER Coaxial Hex Crimp Hand Tool assembly 58433-2, which includes dies 58436-1.

<sup>3</sup>Bulk packaged.

BELDEN is a trademark of Belden Wire and Cable Company.

BERK-TEK is a trademark of Nexans, Inc.

COMM/SCOPE is a trademark of Commscope, Inc.

**Note:** Part Numbers are RoHS compliant except: ♦ Indicates non-RoHS compliant.

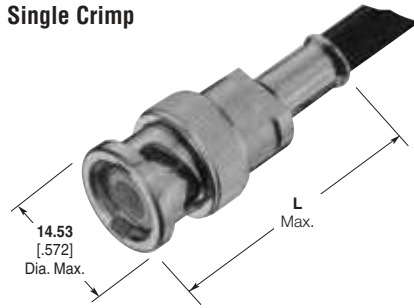
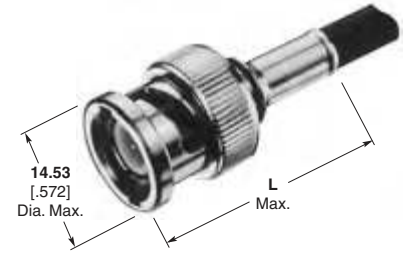
**BNC Connectors, 50 Ohm (Continued)**
**Plugs, Crimp (Continued)**
**Single Crimp**

**Hex and O Crimp**

RG/U Cable	Termination Type	Body Plating	Dielectric	Style	Dim. L	CERTI-CRIMP Hand Tool with Integral Die	Interchangeable Dies for PRO-CRIMPER Hand Tool 354940-1 or PRO-CRIMPER Adapter 679304-1	Interchangeable Dies for Hand Tool 69710-1 & 626 Pneu. Head 318161-1	Part No.
124, 140, 210, 62, 62A, 62B, 59, 59A, 59B, BELDEN 9291, 9209, 9269	Hex Crimp	Nickel	Polyethylene	Commercial	<b>33.53</b> 1.320	—	58436-12	—	<b>1-5221128-1</b>
	O Crimp	Nickel	Polyethylene	Commercial	<b>27.69</b> 1.090	220187-2	58435-11	220217-2	<b>5227079-7</b>
	O Crimp	Nickel	Polyethylene	Commercial	<b>27.69</b> 1.090	220187-2	58435-11	220217-2	<b>1-5227079-1</b>
	O Crimp	Nickel	PTFE	MIL Type	<b>30.18</b> 1.188	—	58537-1	—	<b>5225395-2</b>
	Single Crimp	Silver	PTFE	MIL Type	<b>33.33</b> 1.312	69141-1	—	—	<b>2-5329445-1</b>
302, BELDEN 88241, 89269, Hi-Temp 62A, Times PL62, BERK-TEK, BTDC-59, BTDC-62	Hex Crimp	Nickel	Polyethylene	Commercial	<b>33.53</b> 1.320	—	58436-12	—	<b>1-5221128-1</b>
	O Crimp	Nickel	PTFE	MIL Type	<b>34.14</b> 1.344	69477-1	58537-1	69669-1	<b>4-5225395-1</b>
Hi-Temp 59, Times PL59, PLF59 (20 AWG C.C.)	O Crimp	Nickel	Polyethylene	Commercial	<b>33.33</b> 1.312	—	58537-1	—	<b>5-5227079-3</b>
BELDEN 9104, 9240, 9112, 9167, 9259, 9266, Times FM-59	Hex Crimp	Nickel	Polyethylene	Commercial	<b>33.53</b> 1.320	—	58436-12	—	<b>1-5221128-7</b>
	O Crimp	Nickel	PTFE	MIL Type	<b>30.94</b> 1.218	—	58537-1	69669-1	<b>2-5225395-0</b>
BELDEN 8281, 9141, 9231, Western Electric 724, 728, 3049	Single Crimp	Silver	Polypropylene	MIL Type	<b>41.50</b> 1.634	69652	—	220000	<b>5330878</b>
8, 8A, 213	O Crimp	Silver	PTFE	MIL Type	<b>27.31</b> 1.075	220015-1	—	—	<b>5225886-1</b>
11, 11A	O Crimp	Silver	PTFE	MIL Type	<b>47.63</b> 1.875	220015-1	—	—	<b>5225886-4</b>
BELDEN 9914, Times FM-8	O Crimp	Silver	PTFE	MIL Type	<b>47.63</b> 1.875	220015-1	—	—	<b>5225886-7</b>
Alpha 9847, BELDEN 8213, 9292	O Crimp	Silver	PTFE	MIL Type	<b>47.63</b> 1.875	220015-1	—	—	<b>225886-5 ♦</b>
9, 9A, 9B, 214	O Crimp	Silver	PTFE	MIL Type	<b>52.38</b> 2.062	220015-1	—	—	<b>5225886-1</b>

<sup>1</sup>Order Tyco Electronics PRO-CRIMPER Coaxial "O" Crimp Hand Tool assembly 58433-1, which includes dies 58435-1.

<sup>2</sup>Order Tyco Electronics PRO-CRIMPER Coaxial Hex Crimp Hand Tool assembly 58433-2, which includes dies 58436-1. Tyco Electronics PRO-CRIMPER II Hand Tool Frame without dies Part No. 354940-1

BELDEN is a trademark of Belden Wire and Cable Company.  
BERK-TEK is a trademark of Nexans, Inc.

**Note:** Part Numbers are RoHS compliant except: ♦ Indicates non-RoHS compliant.

**BNC Connectors, 50 Ohm (Continued)**

**Plugs, Twist-On**

**Related Product Data**

Twist-On plugs must be used with cable that has a solid conductor. These plugs are not recommended for applications where the cable frequently moves or flexes.

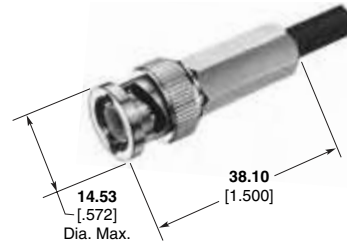

Mating Twist-On Jack — Page 52

RG/U Cable	Contact Plating	Body Plating	Dielectric	Style	Part No.
59, 59A, 59B	Gold	Nickel	Polymethyl-pentene	Commercial	5414265-3

**Right-Angle Plugs, Crimp**

**Single Crimp**

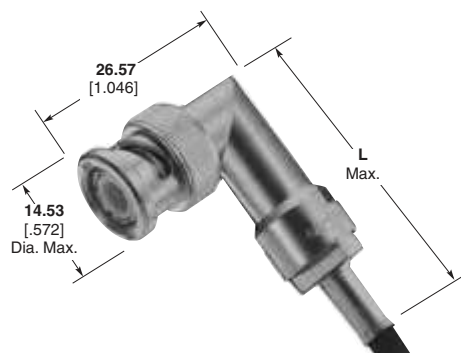

**Hex and O Crimp**

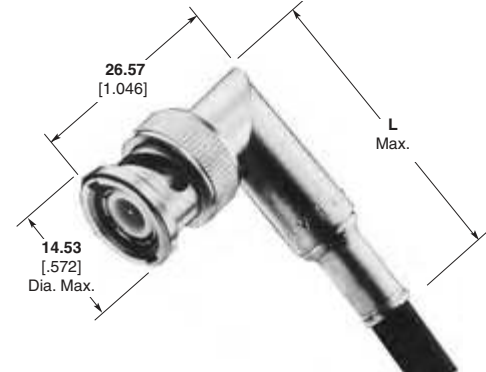

RG/U Cable	Termination Type	Center Contact Plating	Body Plating	Dielectric	Style	Dim. L	CERTI-CRIMP Hand Tool with Integral Die	Interchangeable Dies for PRO-CRIMPER Hand Tool 354940-1 or PRO-CRIMPER Adapter 679304-1	Interchangeable Dies for Hand Tool 69710-1 & 626 Pneu. Head 318161-1	Part No.
174, 188, 188A, 316	Hex Crimp	Gold	Nickel	Polymethyl-pentene	Commercial	39.45 1.553	—	58436-3	—	5413959-3
	Single Crimp	Gold	Silver	PTFE	MIL Type	44.45 1.750	—	91910-1	69422	5331178
179, 179A, 179B, 161, 187, 187A, BELDEN 9221	Hex Crimp	Gold	Nickel	Polymethyl-pentene	Commercial	39.45 1.553	—	58436-3	—	5413959-4
180, 180A, 180B, 195, 195A	Hex Crimp	Gold	Nickel	Polymethyl-pentene	Commercial	39.45 1.553	—	58436-3	—	5413959-5
BELDEN 9907, 89907, 8219, COMM/SCOPE 2104, 3104	Hex Crimp	Gold	Nickel	Polymethyl-pentene	Commercial	39.45 1.553	—	58436-1	—	5413959-6
58, 58A, 58B, 58C	Hex Crimp	Gold	Nickel	Polymethyl-pentene	Commercial	39.45 1.553	—	58436-1	—	5413959-1
	O Crimp	Gold	Nickel	PTFE	MIL Type	37.29 1.468	69478-1	220189-3	69727-1	5225974-1
	Single Crimp	Gold	Silver	PTFE	MIL Type	44.45 1.750	—	91904-1	69223-1	5331175
55, 55A, 55B, 223	O Crimp	Gold	Nickel	PTFE	MIL Type	37.29 1.468	69478-1	220189-3	69727-1	5225974-2
	Single Crimp	Gold	Silver	PTFE	MIL Type	44.45 1.750	—	91904-3	69429-1	5331182
142, 142A, 142B, 400	Single Crimp	Gold	Silver	PTFE	MIL Type	44.45 1.750	69331-1	—	69429-1	5331182
124, 140, 210, 62, 62A, 62B, 59, 59A, 59B, BELDEN 9291, 9209, 9269	O Crimp	Gold	Nickel	PTFE	MIL Type	37.29 1.468	—	58537-1	69669-1	5225974-5

BELDEN is a trademark of Belden Wire and Cable Company.  
COMM/SCOPE is a trademark of Commscope, Inc.

**Note:** Part Numbers are RoHS compliant except: ♦ Indicates non-RoHS compliant.

**BNC Connectors, 50 Ohm** (Continued)

**Jacks, Crimp**

**Single Crimp**

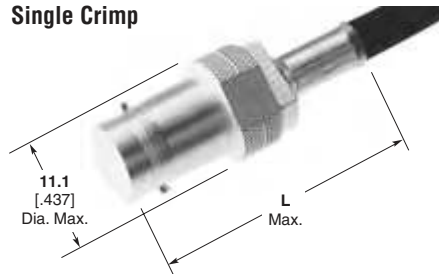

**Hex and O Crimp**

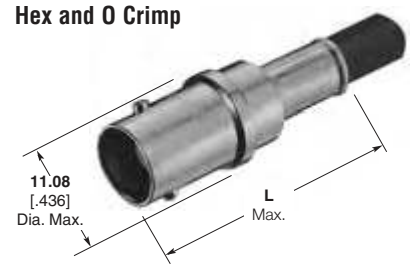

RG/U Cable	Termination Type	Center Contact Plating	Body Plating	Dielectric	Style	Dim. L	CERTI-CRIMP Hand Tool with Integral Die	Interchangeable Dies for PRO-CRIMPER Hand Tool 354940-1 or PRO-CRIMPER Adapter 679304-1	Interchangeable Dies for Hand Tool 69710-1 & 626 Pneu. Head 318161-1	Part No.
174, 188, 188A, 316	Hex Crimp	Gold	Nickel	Polymethyl-pentene	Commercial	<b>33.02</b> 1.300	—	58436-3	—	<b>5413779-3</b>
	O Crimp	Gold	Nickel	Polypropylene	Commercial	<b>30.48</b> 1.200	—	1424050-1	220217-3	<b>5228979-7</b>
	O Crimp	Gold	Nickel	PTFE	MIL Type	<b>30.48</b> 1.200	—	1424050-1	220026-1	<b>5225396-7</b>
	Single Crimp	Gold	Silver	PTFE	MIL Type	<b>33.33</b> 1.312	—	—	69422	<b>2-5330062-1</b>
179, 179A, 179B, 161, 187, 187A, BELDEN 9221	Hex Crimp	Gold	Nickel	Polymethyl-pentene	Commercial	<b>33.02</b> 1.300	—	58436-3	—	<b>2-5413779-4</b>
58, 58A, 58B, 58C	O Crimp	Gold	Nickel	Polypropylene	Commercial	<b>30.48</b> 1.200	220187-1	58435-1 <sup>1</sup>	220217-1	<b>5228979-5</b>
	O Crimp	Gold	Nickel	PTFE	MIL Type	<b>30.48</b> 1.200	—	91901-1	69727	<b>5225396-1</b>
223, 55, 55A, 55B	Single Crimp	Gold	Silver	PTFE	MIL Type	<b>33.33</b> 1.312	69140-2	91904-3	69424	<b>2-5329452-2</b>
124, 140, 210, 62, 62A, 62B, 59, 59A, 59B, BELDEN 9291, 9209, 9269	O Crimp	Gold	Nickel	Polypropylene	Commercial	<b>30.48</b> 1.200	220187-2	58435-1 <sup>1</sup>	220217-2	<b>5228979-6</b>
	O Crimp	Gold	Nickel	PTFE	MIL Type	<b>30.48</b> 1.200	—	58537-1	69669-1	<b>5225396-2</b>

<sup>1</sup>Order Tyco Electronics PRO-CRIMPER Coaxial "O" Crimp Hand Tool assembly 58433-1, which includes dies 58435-1.

BELDEN is a trademark of Belden Wire and Cable Company.

**Note:** Part Numbers are RoHS compliant except: ♦ Indicates non-RoHS compliant.

**BNC Connectors, 50 Ohm (Continued)**

**Jacks, Twist-On**

**Related Product Data**

Twist-on jacks must be used with cable that has a solid conductor. These jacks are not recommended for applications where the cable frequently moves or flexes.

**Mating Twist-On Plug** — Page 50

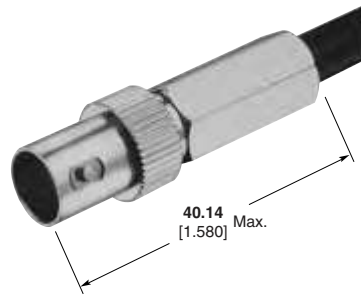

RG/U Cable	Center Contact	Body Plating	Dielectric	Style	Part No.
59, 59A, 59B	Gold	Nickel	Acetal	Commercial	222428-1

**Panel Jacks, Crimp**

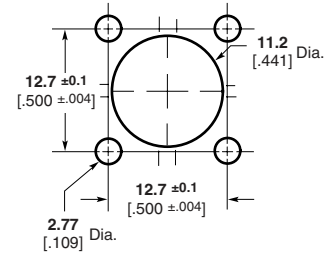
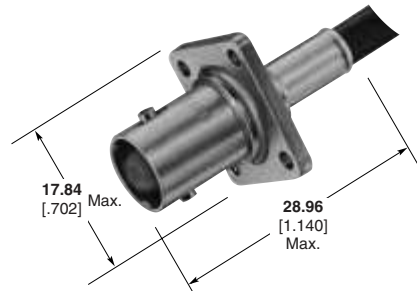

**Recommended Panel Cutout**

RG/U Cable	Termination Type	Center Contact Plating	Body Plating	Dielectric	Style	CERTI-CRIMP Hand Tool with Integral Die	Interchangeable Dies for PRO-CRIMPER Hand Tool 354940-1 or PRO-CRIMPER Adapter 679304-1	Interchangeable Dies for Hand Tool 69710-1 & 626 Pneu. Head 318161-1	Part No.
174, 188, 188A, 316	O Crimp	Gold	Nickel	PTFE	MIL Type	—	1424050-1	220026-1	5225397-7
58, 58A, 58B, 58C	O Crimp	Gold	Nickel	PTFE	MIL Type	69478-1	91901-1	69727	5225397-1
124, 140, 210, 62, 62A, 62B, 59, 59A, 59B, BELDEN 9291, 9209, 9269, 89269	O Crimp	Gold	Nickel	PTFE	MIL Type	69477-1	58537-1	69669-1	5225397-2

BELDEN is a trademark of Belden Wire and Cable Company.

**Note:** Part Numbers are RoHS compliant except: ♦ Indicates non-RoHS compliant.

**BNC Connectors, 50 Ohm (Continued)**

**Bulkhead Jacks, Crimp**

**Note:** Panel Insulating Bushings — Page 54

**Single Crimp**

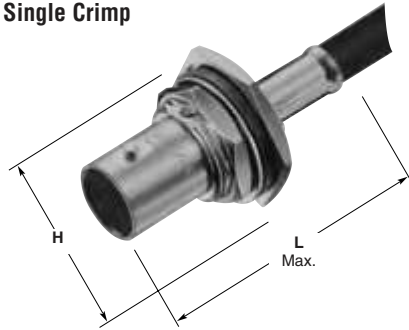

**Hex and O Crimp**

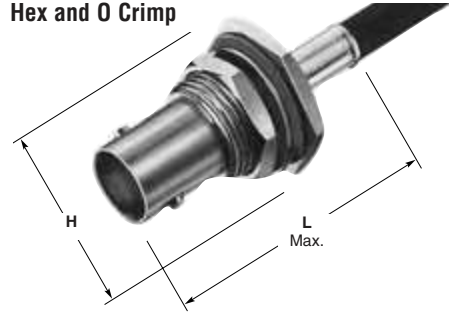

**Recommended Panel Cutouts**  
Maximum Panel Thickness 3.18 [.125]

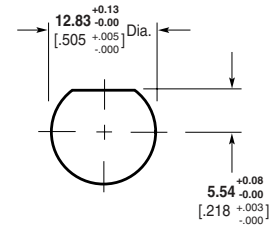
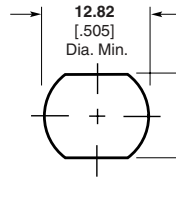

H = 11/16" across flats, 20.32 [.800] Max. across points

RG/U Cable	Termination Type	Center Contact Plating	Body Plating	Dielectric	Style	Dim. L	CERTI-CRIMP Hand Tool with Integral Die	Interchangeable Dies for PRO-CRIMPER Hand Tool 354940-1 or PRO-CRIMPER Adapter 679304-1	Interchangeable Dies for Hand Tool 69710-1 & 626 Pneu. Head 318161-1	Part No.
174, 188, 188A, 316	Hex Crimp	Gold	Nickel	Polymethyl-pentene	Commercial	36.83 1.450	—	58436-3	—	5413771-3
	O Crimp	Gold	Nickel	Polypropylene	Commercial	34.93 1.375	—	—	220217-3	5228980-7
	O Crimp	Gold	Nickel	PTFE	MIL Type	35.71 1.406	—	—	220026-1	5225398-7
	Single Crimp	Gold	Silver	PTFE	MIL Type	32.13 1.265	—	—	69422	2-5330063-1
179, 179A, 179B, 161, 187, 187A, BELDEN 9221	O Crimp	Gold	Nickel	PTFE	MIL Type	35.71 1.406	—	1424050-1	220026-1	5225398-8
	Single Crimp	Gold	Silver	PTFE	MIL Type	32.13 1.265	—	91910-1	69408	2-5329458-1
Times RD316	O Crimp	Gold	Nickel	PTFE	MIL Type	35.71 1.406	—	91904-1	69669-2	1-5225398-5

BELDEN is a trademark of Belden Wire and Cable Company.

**Note:** Part Numbers are RoHS compliant except: ♦ Indicates non-RoHS compliant.

**BNC Connectors, 50 Ohm (Continued)**

**Bulkhead Jacks, Crimp (Continued)**

**Note:** Panel Insulating Bushings—  
at the bottom of this page

**Single Crimp**



**Recommended Panel Cutouts**  
Maximum Panel Thickness 3.18 [ .125]

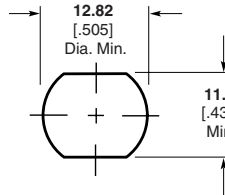

**Hex and O Crimp**

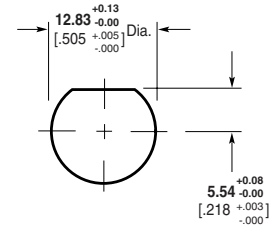

H = 11/16" across flats, 20.32 [.800] Max. across points

RG/U Cable	Termination Type	Center Contact Plating	Body Plating	Dielectric	Style	Dim. L	CERT-CRIMP Hand Tool with Integral Die	Interchangeable Dies for PRO-CRIMPER Hand Tool 354940-1 or PRO-CRIMPER Adapter 679304-1	Interchangeable Dies for Hand Tool 69710-1 & 626 Pneu. Head 318161-1	Part No.
58, 58A, 58B, 58C, BELDEN 88240, BERK-TEK BTDC-58, COMM/SCOPE 2135	Hex Crimp	Gold	Nickel	Polymethyl-pentene	Commercial	36.83 1.450	—	58436-1	—	5413771-1
58, 58A, 58B, 58C	O Crimp	Gold	Nickel	Polypropylene	Commercial	34.93 1.375	220187-1	58435-11	220217-1	5228980-5
	O Crimp	Gold	Nickel	PTFE	MIL Type	41.28 1.625	—	91901-1	69727	5225398-1
	Single Crimp	Gold	Silver	PTFE	MIL Type	32.13 1.265	—	91904-4	69223-1	2-5329456-1
223, 55, 55A, 55B	O Crimp	Gold	Nickel	PTFE	MIL Type	35.71 1.406	—	91901-1	69727	5225398-3
142, 142A, 142B, 400	O Crimp	Gold	Nickel	PTFE	MIL Type	35.71 1.406	—	91901-1	69727	5225398-6
124, 140, 210, 62, 62A, 62B, 59, 59A, 59B, BELDEN 9291, 9209, 9269	O Crimp	Gold	Nickel	Polypropylene	Commercial	34.93 1.375	220187-2	58435-11	220217-2	5228980-6

<sup>1</sup>Order Tyco Electronics PRO-CRIMPER Coaxial "O" Crimp Hand Tool assembly 58433-1, which includes dies 58435-1.

**Panel Insulating Bushings for Bulkhead Jacks**

**Material** — Nylon

**Note:** Can not be used with single crimp bulkhead jacks.

BELDEN is a trademark of Belden Wire and Cable Company.  
BERK-TEK is a trademark of Nexans, Inc.  
COMM/SCOPE is a trademark of Commscope, Inc.

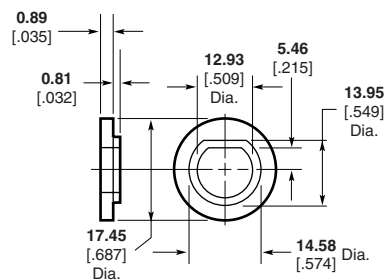

**Part No. 330620 (2 Required)**

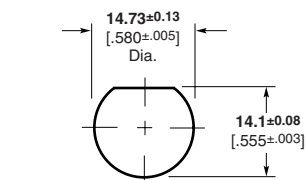

**Recommended Panel Cutout**

**Note:** Part Numbers are RoHS compliant except: ♦ Indicates non-RoHS compliant.



**BNC Connectors, 50 Ohm (Continued)**

**Plugs, for JIS Cables, Crimp**

**Plating**

**Body** — Nickel

**Center Contact** — Gold



JIS Cable	Termination Type	Dielectric	Dim. L	Interchangeable Dies for PRO-CRIMPER Hand Tool 354940-1 or PRO-CRIMPER Adapter 679304-1	Part No.
3D-2V	Hex Crimp	Polyethylene	33.53 1.320	58436-1	3-5221128-1

**Bulkhead Solder Jacks, Front Mount**

**Body Plating** — Nickel

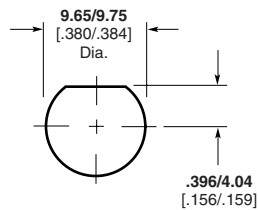

**Recommended Panel Cutout**

**Without Solder Terminal**

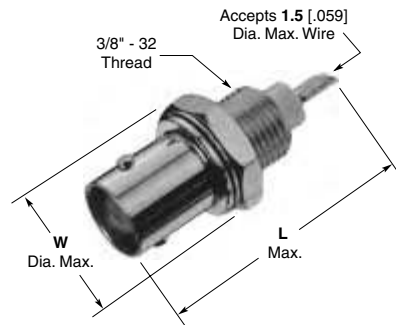

**With Solder Terminal**

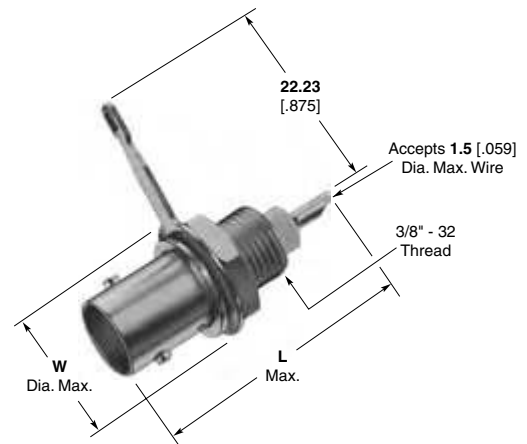

Contact Material	Dielectric	Dimensions		Panel Thickness	Insulating Bushing	Part No.	
		L	W			Without Solder Terminal*	With Solder Terminal**
Silver	VALOX	26.93 1.060	13.09 .515	1.17-3.18 .046-.125	227223-1 or 221951-1	5227754-3	5227755-3
		33.33 1.312	13.09 .515	1.17-6.35 .046-.250	227223-1 or 221951-1	—	5227169-7
Gold	VALOX	26.93 1.060	13.09 .515	1.17-3.18 .046-.125	227223-1 or 221951-1	5227754-2	5227755-2
		33.33 1.312	13.09 .515	1.17-6.35 .046-.250	227223-1 or 221951-1	5227169-4	5227169-8
	PTFE	26.93 1.060	13.09 .515	1.17-3.18 .046-.125	227223-1 or 221951-1	5227715-3	5227716-3
		33.33 1.312	13.09 .515	1.17-6.35 .046-.250	227223-1 or 221951-1	—	5227169-5
Tin	VALOX	26.93 1.060	13.09 .515	1.17-3.18 .046-.125	227223-1 or 221951-1	5227754-1	5227755-1

\*Includes lockwasher and jam nut.

\*\*Includes solder terminal and jam nut.

VALOX is a trademark of General Electric Company.

**Note:** Part Numbers are RoHS compliant except: ♦ Indicates non-RoHS compliant.

**BNC Connectors, 50 Ohm (Continued)**

**Insulating Bushings**

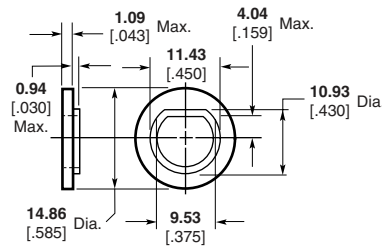

**Part No. 227223-1**

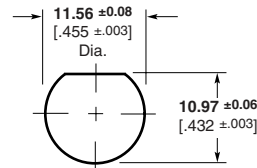

**Recommended Panel Cutout**

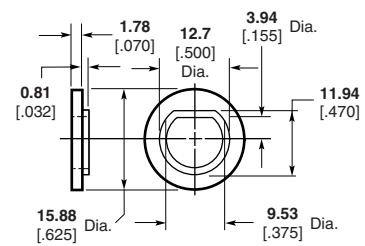

**Part No. 221951-1**

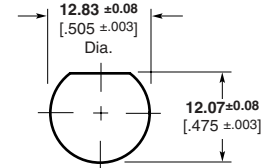

**Recommended Panel Cutout**

**Isolated Bulkhead Solder Jacks, Front Mount**

**Plating**

**Body** — Nickel

**Dielectric** — White VALOX

Center Contact Plating	Flange & Thread Material	Part No.
Tin	VALOX	5227726-1
Silver	VALOX	5227726-2
Gold	VALOX	5227726-3

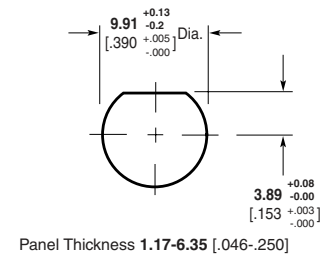
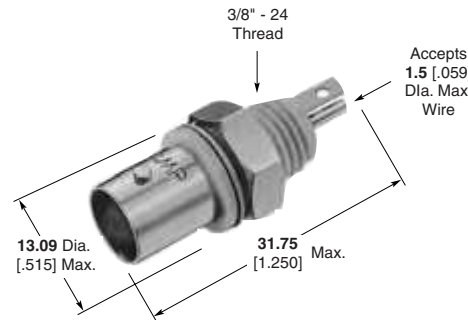

**Recommended Panel Cutout**

**Plating**

**Body** — Nickel

**Center Contact** — Silver

**Dielectric** — Black VALOX

**Flange & Thread Material** — Black VALOX

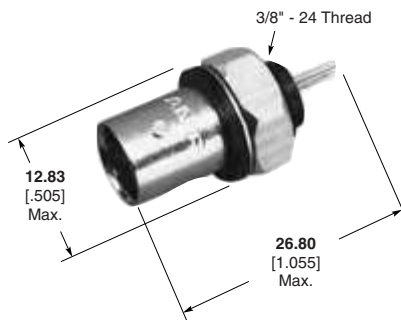

**Part No. 5414194-1**

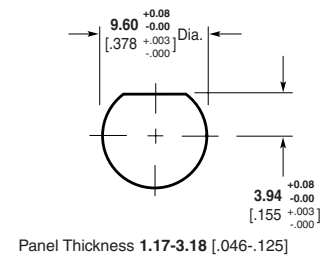

**Recommended Panel Cutout**

**Sealed Bulkhead Solder Jack, Rear Mount**

**Plating**

**Body** — Nickel

**Center Contact** — Gold

**Dielectric** — Polymethylpentene

This connector is designed to prevent moisture from entering the interface from the rear of the connector.

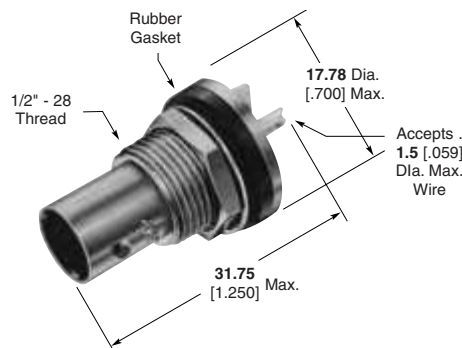

**Part No. 5227426-1**

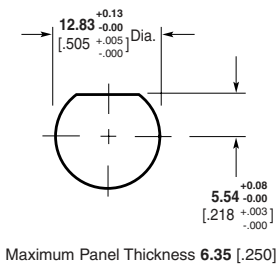

**Recommended Panel Cutout**

**Note:** Part Numbers are RoHS compliant except: ♦ Indicates non-RoHS compliant.

VALOX is a trademark of General Electric Company.

**BNC Connectors, 50 Ohm (Continued)**

**Right-Angle Jacks  
PC Board/Panel Mount**

**Body** — Nickel  
**Dielectric** — Polymethylpentene

**VALOX Body**

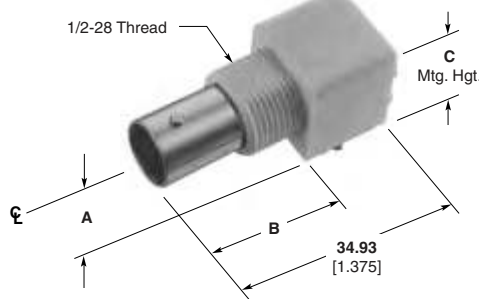

**Metal Body**

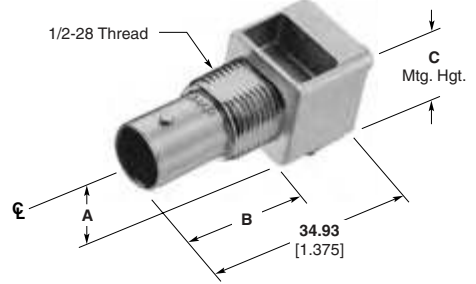

**Mounting Post Style**

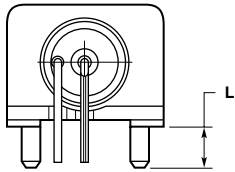

**Compliant Post**

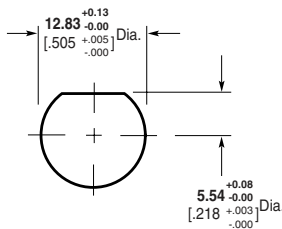
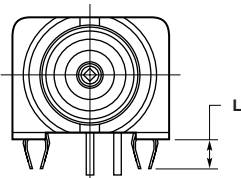

Maximum Panel Thickness 6.1 [240]

**Recommended Panel Cutout**

**Lockwasher and Jam Nut**



**Part No.**  
1-329632-2

**Part No.**  
1-329631-2

**Without Mounting Posts**

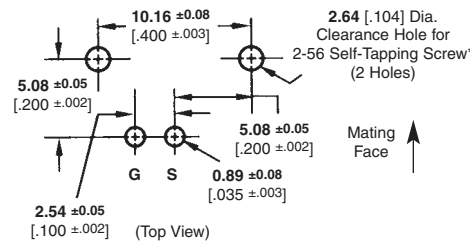

**With Mounting Posts**

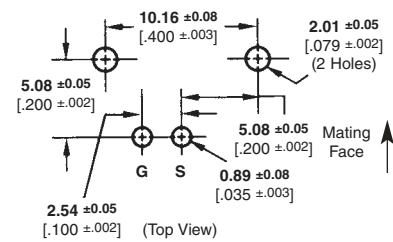

**Recommended PC Board Layouts**

Body Material	Center Contact Plating	Dimensions			Part No.				
		A	B	C	Without Mounting Posts	With Mounting Posts	L	With Compliant Posts	L
VALOX, White	Tin	8.59 .338	21.21 .835	15.88 .625	5226990-1	5227161-1	3.48 .137	—	—
	Gold1	8.59 .338	21.21 .835	15.88 .625	5226990-3	5227161-3	3.48 .137	—	—
	Gold1	6.91 .272	21.21 .835	13.18 .519	—	5227161-7	3.48 .137	—	—
VALOX, Black	Tin	8.59 .338	21.21 .835	15.88 .625	—	5227161-2	3.48 .137	—	—
	Gold1	8.59 .338	21.21 .835	15.88 .625	5226990-6	5227161-6	3.48 .137	—	—
	Gold1	6.91 .272	21.21 .835	13.18 .519	—	5227161-9	3.48 .137	—	—
Metal	Gold1	6.17 .243	21.21 .835	11.68 .460	—	5415046-1	—	—	—
	Tin	8.26 .325	20.83 .820	15.88 .625	—	5227661-1	3.48 .137	—	—
	Gold1	8.26 .325	20.83 .820	15.88 .625	5227676-1	5227677-1	3.48 .137	—	—
	Gold1	6.91 .272	20.83 .820	12.70 .500	1274668-1	5413879-1	3.48 .137	—	—
High Temp. Housing	Gold1	6.91 .272	21.21 .835	13.18 .519	—	—	—	5415218-5	2.79 .110

**Plating:**

Gold1 — 0.00076 [0.00030] thick

Gold2 — 0.00127 [0.00050] thick

**Note:** If an Insulating Bushing is required see part number 330620 and Panel Cutout on page 54.

VALOX is a trademark of General Electric Company.

**Note:** Part Numbers are RoHS compliant except: ♦ Indicates non-RoHS compliant.

**BNC Connectors, 50 Ohm (Continued)**

**Vertical Jacks  
PC Board/Panel Mount**

**Plating**  
**Body** — Nickel  
**Dielectric** — Polymethylpentene

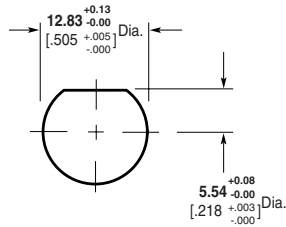

Maximum Panel Thickness 6.1 [.240]

**Recommended Panel Cutout**

**Lockwasher and Jam Nut**



**Part No.**  
1-329632-2

**Part No.**  
1-329631-2

**VALOX Body**

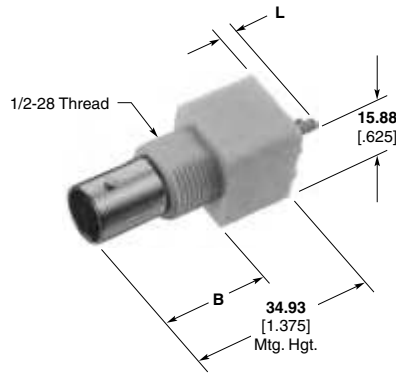

**Metal Body**

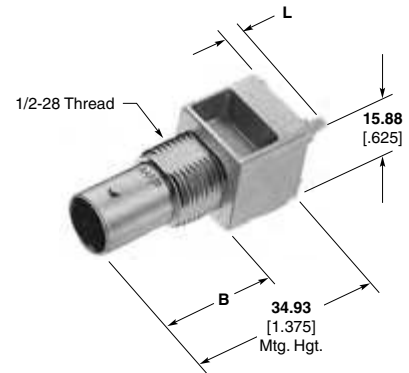

Body Material	Center Contact Plating	Dim. B	Dim. L	Part No.	
				Without Mounting Posts	With Mounting Posts
VALOX, White	Tin	21.21 .835	3.48 .137	5226993-1	5227222-1
	Gold	21.21 .835	3.48 .137	5226993-3	5227222-3
VALOX, Black	Tin	21.21 .835	3.48 .137	5226993-2	5227222-2
	Gold	21.21 .835	3.48 .137	5226993-6	5227222-6
Metal	Tin	20.83 .820	3.48 .137	—	5227671-1
	Gold	20.83 .820	3.48 .137	—	5227673-1

**Note:** If an Insulating Bushing is required see part number 330620 and Panel Cutout on page 54.

**Without Mounting Posts**

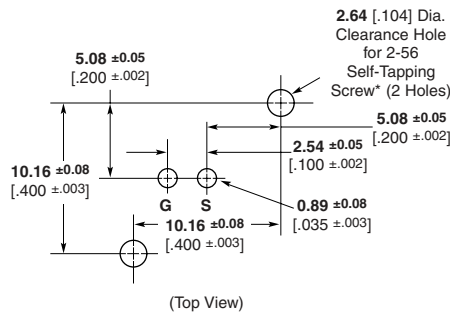

**With Mounting Posts**

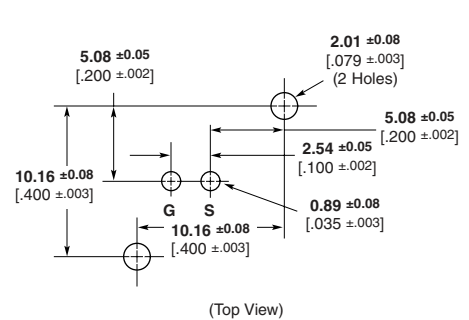

**Recommended PC Board Layouts**

\* Screw for board thickness of 2.38 [.093] or greater **Part No. 221108-2.**  
Screw for thickness of less than 2.38 [.093] **Part No. 221108-4.**

VALOX is a trademark of General Electric Company.

**Note:** Part Numbers are RoHS compliant except: ♦ Indicates non-RoHS compliant.

**BNC Connectors, 50 Ohm (Continued)**

**Jacks with  
Mounting Flanges  
PC Board/Panel Mount**

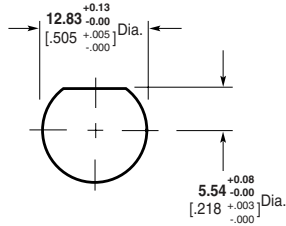

Maximum Panel Thickness 6.1 [.240]

**Recommended Panel Cutout**

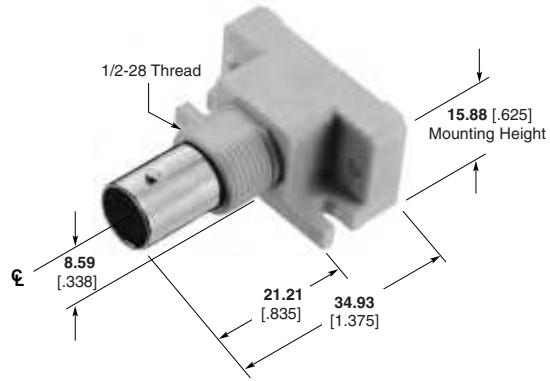

Body Material	Center Contact Plating	Part No.
VALOX, White	Tin	5226978-1
	Gold	5226978-3

**Lockwasher and Jam Nut**



Part No.  
1-329632-2



Part No.  
1-329631-2

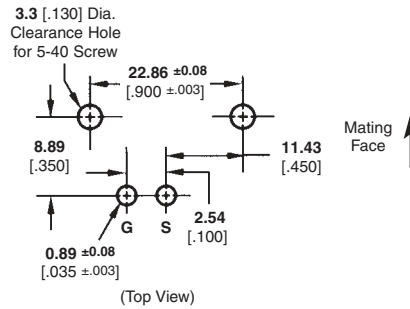

**Recommended PC Board Layout**

VALOX is a trademark of General Electric Company.

**Note:** Part Numbers are RoHS compliant except: ♦ Indicates non-RoHS compliant.

**BNC Connectors, 50 Ohm (Continued)**

**Vertical Metalized Jacks  
PC Board Mount**

**Recommended PC Board Layouts**

**Style A**

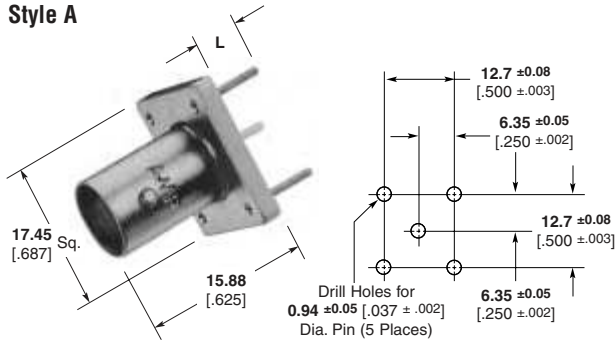

**Style B**

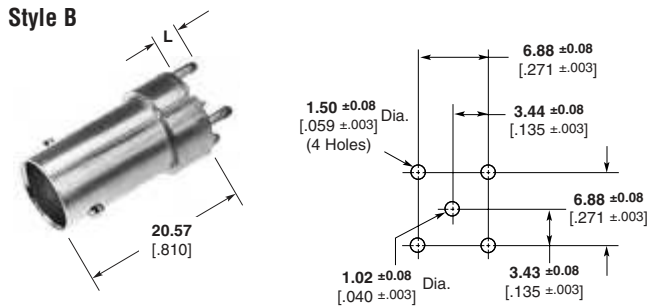

**Style C**

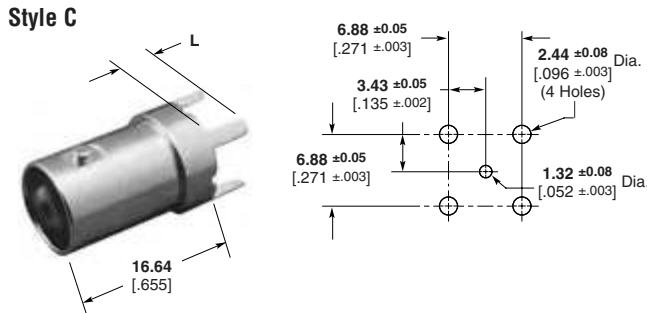

Body Plating	Center Contact Plating	Dielectric	Style	Leg Length L	Part No.
	Silver	VALOX	A	6.35 .250	5227699-1
	Gold	VALOX	A	6.35 .250	5227699-2
	Tin	VALOX	A	6.35 .250	5227699-3
Nickel	Gold	VALOX	A	3.81 .150	5414460-1 <sup>1</sup>
	Silver	VALOX	C	4.45 .175	5222420-1
	Gold	VALOX	E	6.35 .250	5415189-1
	Gold	PTFE	B	3.30 .130	5413969-2
Tin-Lead	Silver	VALOX	C	3.18 .125	5414305-1
	Gold	VALOX	D	3.43 .135	5221123-2

<sup>1</sup>With .76 [0.030] standoffs on top of legs.

**Style D**

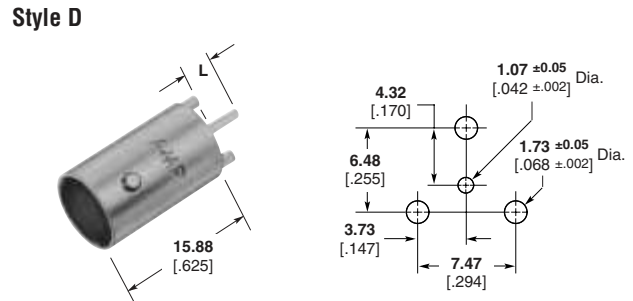

**Style E (Panel Mount)**

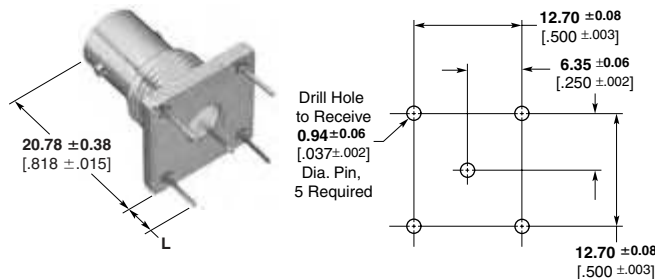

VALOX is a trademark of General Electric Company.

**Note:** Part Numbers are RoHS compliant except: ♦ Indicates non-RoHS compliant.

**BNC Connectors, 50 Ohm (Continued)**

**Vertical Metalized Jacks, PC Board Mount**

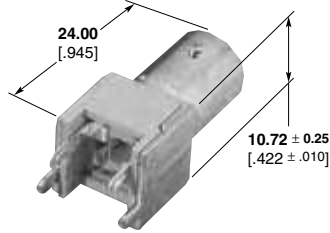

**Part No. 1274314-1 (Switching)**

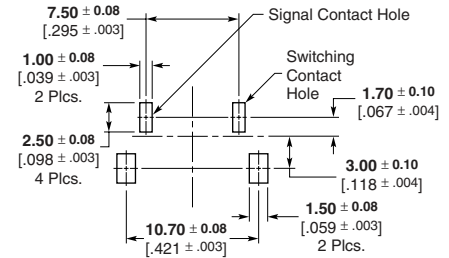

**Recommended PC Board Layout**

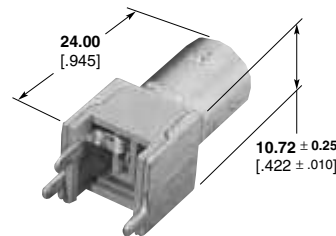

**Part No. 1274315-1**

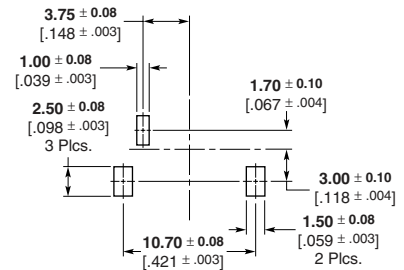

**Recommended PC Board Layout**

Body Plating	Contact Plating	Dielectric	Part No.
Tin	Silver	Polyphenylene	<b>6274314-1</b>
Tin	Silver	Polyphenylene	<b>6274315-1</b>

**Press Fit Vertical Metalized Jack, PC Board Mount**

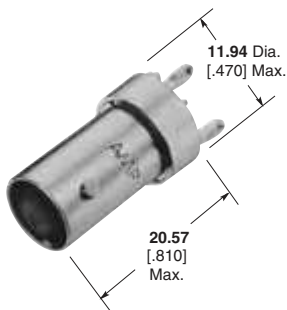

**Part No. 5222006-1**

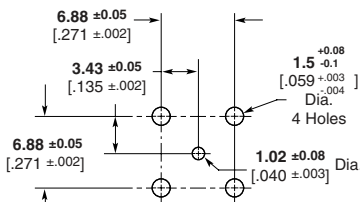

**Recommended PC Board Layout**  
PC Board Thickness Not Less Than 0.99 [0.093]

**Insulating Bushing**

**Material** — Polypropylene  
**Part No. 222163-1**

Only to be used on Part Nos. 5222006-1 & 5222462-1

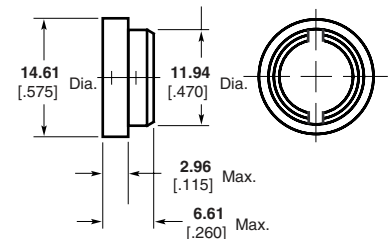

**Note:** Part Numbers are RoHS compliant except: ♦ Indicates non-RoHS compliant.



**BNC Connectors, 50 Ohm (Continued)**

**Right-Angle Metalized Jacks,  
PC Board Mount**

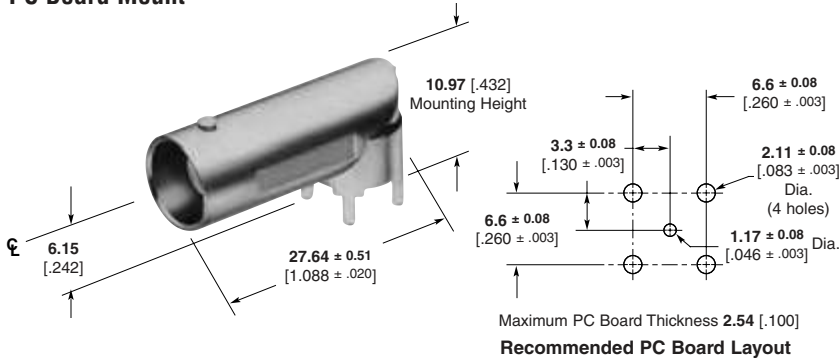

Body Plating	Dielectric	Center Contact Length	Part No.
Nickel	Polymethyl-pentene	4.34 .171	5413631-1
Tin	PTFE	4.34 .171	5413631-2
Nickel	Polymethyl-pentene	3.33 .131	5413631-3

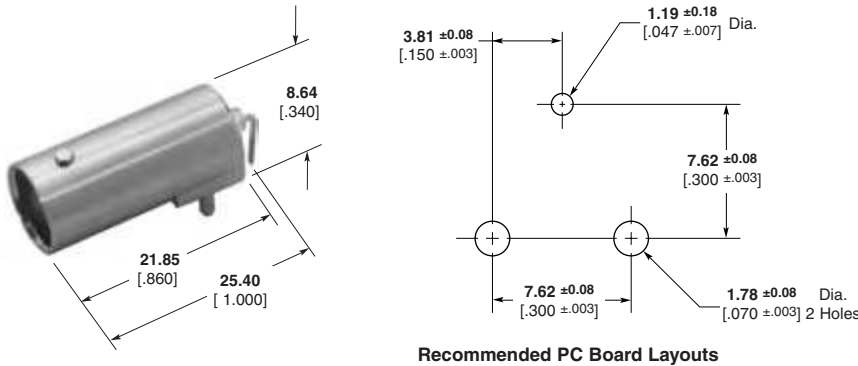

Body	Dielectric	Contact	Part No.
Nickel	TPX	Gold	5414373-1

**Right-Angle Metalized Jacks,  
PC Board/Panel Mount**

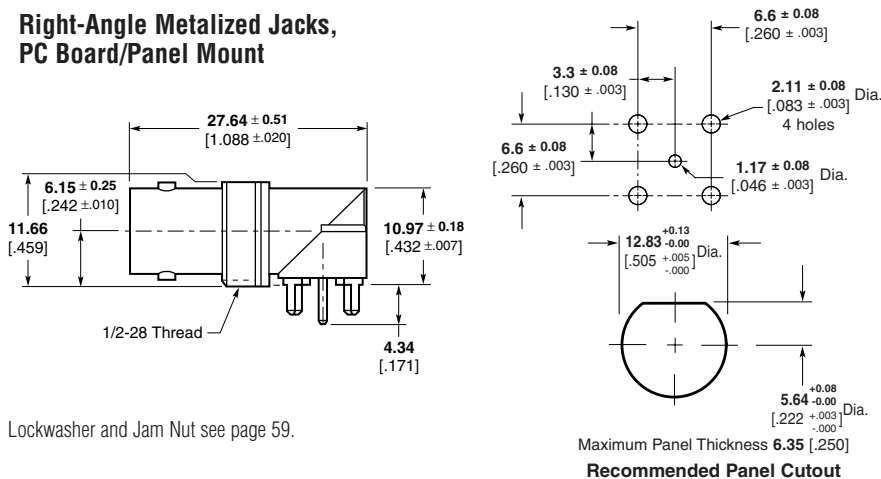

Body Plating	Dielectric	Part No.
Tin	PTFE	5415025-2
Tin	TPX	5415025-1

Lockwasher and Jam Nut see page 59.

TPX is a trademark of Mitsui Chemicals America, Inc.

**Note:** Part Numbers are RoHS compliant except: ♦ Indicates non-RoHS compliant.

**BNC Connectors, 50 Ohm (Continued)**

**Tee Adapters**

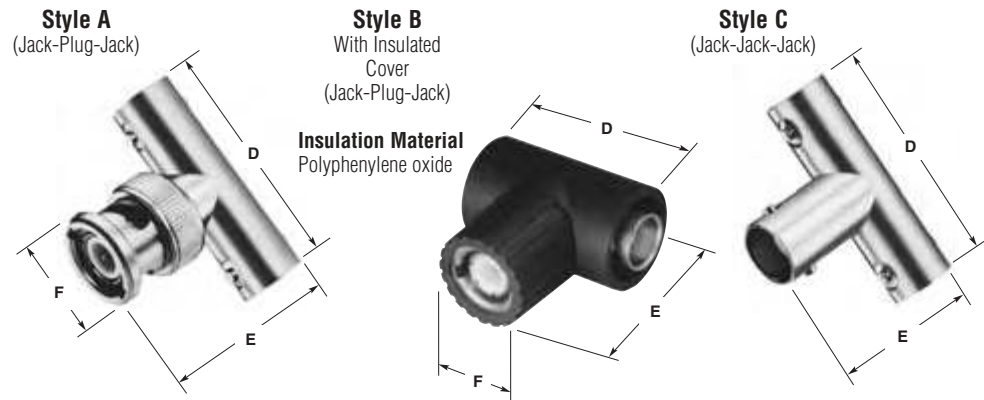

Style	Body Material and Plating	Center Contact Material and Plating	Dielectric	Dimensions			Comparable UG/U Connector	Packaging No. Per Pkg.	Part No.
				D	E	F			
A	Brass, Nickel	BE CU, Gold (30) <sup>2</sup>	PTFE	32.54 1.281	26.19 1.031	14.27 .562	274A	Bulk (100)	221543-2
		PH BR, Gold (15) <sup>2</sup>	Acetal	33.02 1.300	27.31 1.075	14.50 .571	—	Bulk (100)	5413592-2
	Zinc, Nickel	BE CU, Gold (30) <sup>2</sup>	Acetal	33.02 1.300	27.31 1.075	14.50 .571	—	Bulk (100)	5413592-6
		PH BR, Gold (15) <sup>2</sup>	Acetal	33.02 1.300	27.31 1.075	14.50 .571	—	Individual (1) <sup>3</sup>	5413592-9
		BE CU, Silver (200) <sup>2</sup>	Acetal	33.02 1.300	27.31 1.075	14.50 .571	—	Individual (1)	1-5413592-1
B	Zinc, Nickel	BE CU, Gold (30) <sup>2</sup>	Acetal	32.54 1.281	31.12 1.225	17.15 .675	—	Bulk (100)	5413366-21
C	Brass, Nickel	BE CU, Silver (200) <sup>2</sup>	PTFE	32.54 1.281	23.37 .920	—	—	Bulk (100)	221988-1
	Zinc, Nickel	PH BR, Gold (50) <sup>2</sup>	Acetal	32.54 1.281	23.62 .930	—	—	Bulk (100)	5414311-1

<sup>1</sup>Gray insulation cover  
<sup>2</sup>(Microinches min thickness)  
<sup>3</sup>(Special graphics)

**Tee Adapter Covers**

**Material** — Polypropylene, general purpose

Color	Part No.
Black	221586-1
Ivory	221586-3

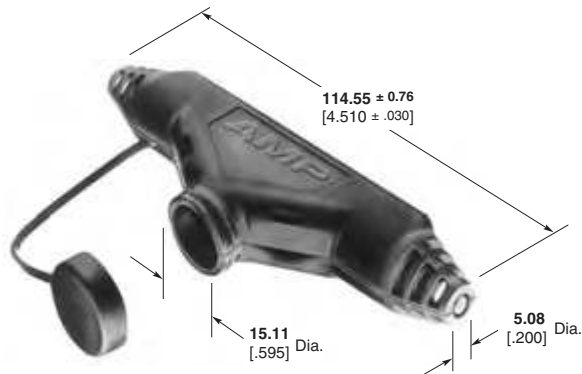

**Note:** Part Numbers are RoHS compliant except: ♦ Indicates non-RoHS compliant.

**BNC Connectors, 50 Ohm (Continued)**

**Jack-Jack Adapters**

**Style A**

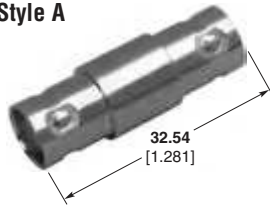

**Style B**



Body Plating	Center Contact Plating	Dielectric	Style	Part No.
Nickel	Silver	PTFE	A	221551-1
Nickel	Gold	PTFE	A	221551-3
Nickel	Gold	Polymethylpentene	B	5414414-1

**Bulkhead Jack-Jack Adapters**

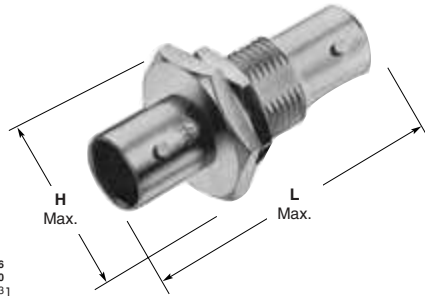
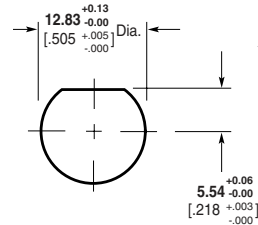

Body Plating	Center Contact Plating	Dimensions		Dielectric	Part No.
		H	L		
Nickel	Silver	17.45 .687	38.10 1.500	PTFE	330024
Nickel	Gold1	17.78 .700	36.07 1.420	Polyethylene	5228226-1
Nickel	Gold2	17.78 .700	36.07 1.420	Polyethylene	5228226-3

**Plating:**  
Gold1—0.00127 [.000050] thick Gold2—0.00076 [.000015] thick  
**Note:** If an Insulating Bushing is required see part number 330620 and Panel Cutout on page 54.

**Recommended Panel Cutout**

H= 11/16 across flats, 20.32 [.800] across points.

**Isolated Bulkhead Jack-Jack Adapter**

Body Plating	Center Contact Plating	Dielectric	Part No.
Nickel	Gold	Polymethylpentene	5414105-1

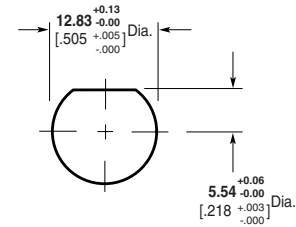
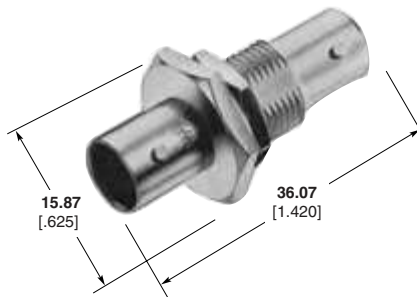

**Recommended Panel Cutout**

H= 11/16 across flats, 20.32 [.800] across points.

**Plug-Plug Adapter**

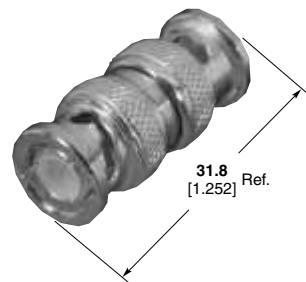

Contact Plating	Body Plating	Part No.
Gold	Nickel	415796-1

**Right-Angle Adapters**

(Jack-Plug)

Body Plating	Center Contact Plating	Dielectric	Part No.
Nickel	Silver	PTFE	5329517
Nickel	Gold	PTFE	5222165-2
Nickel	Gold	Polymethylpentene	5414666-1

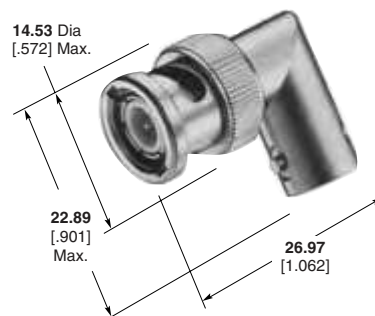

**Note:** Part Numbers are RoHS compliant except: ♦ Indicates non-RoHS compliant.

**BNC Connectors, 50 Ohm (Continued)**

**Terminator Plugs  
50, 75, 93 Ohm**

**Plating**

**Body**—Nickel  
**Center Contact**—Gold  
**Dielectric**—Polyethylene

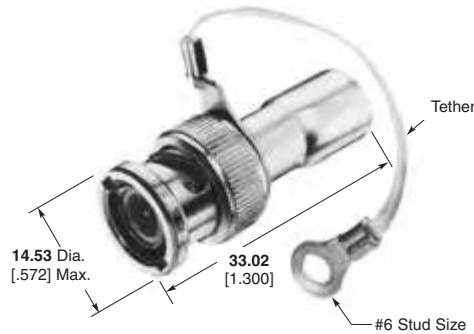

Resistor Specification	Part No.	
	With Tether	Without Tether
1 Watt, 50 Ohm	5221629-1	5221629-4
1 Watt, 75 Ohm	5221629-2	5221629-5
1 Watt, 93 Ohm	—	5221629-6
0.5 Watt, 75 Ohm	—	—
1 Watt, 50 Ohm	1-5221629-6 <sup>1</sup>	—

<sup>1</sup> Tether is conductive with #4 stud size

**Insulated Terminators**

**Insulation Material**  
Polyphenylene oxide

**Long Cover**

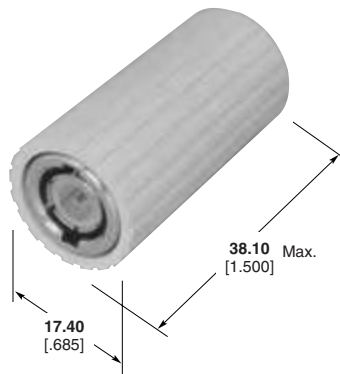

Register Specification	Color	Cover Style	Part No.
1 Watt, 50 Ohm	Gray	Long	5413557-1
		Short	5413364-2
	Black	Long	5413557-2

\* The Short Cover is required when mating the Terminator with a Tee Adapter.

**Jack Covers**

Body Plating	Part No.
Silver	330022
Nickel	1-330022-2



**Shorting Caps**

**Plating**

**Body**—Nickel  
**Center Contact**—Gold

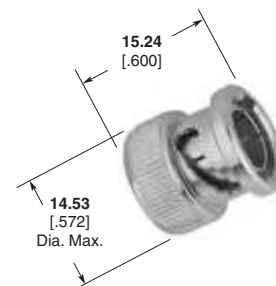

**Part No. 413453-1**

**Note:** Part Numbers are RoHS compliant except: ♦ Indicates non-RoHS compliant.

## BNC Connectors, 75 Ohm

### Plugs, Crimp

These connectors have been designed for optimum performance and have a true 75 ohm impedance the complete length of the connector. The crimp die tooling listed below is different from the equivalent 50 ohm connectors.

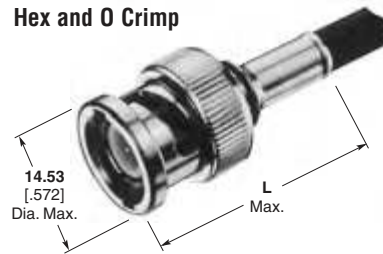

### Plugs

RG/U Cable	Termination Type	Center Contact Plating	Body Plating	Dielectric	Style	Dim. L	Interchangeable Dies for PRO-CRIMPER Hand Tool 354940-1 or PRO-CRIMPER Adapter 679304-1	Interchangeable Dies for Hand Tool 69710-1 & 626 Pneu. Head 318161-1	Part No.
179, 179A, 179B, 187, 187A, 161, BELDEN 9221	Hex Crimp	Gold	Nickel	Polyethelene	Commercial	<b>29.46</b> 1.160	58425-2	—	<b>5413589-8</b>
	O Crimp	Gold	Nickel	Polyethelene	Commercial	<b>35.56</b> 1.140	318451-2	—	<b>5221185-8</b>
AT&T 735A	Hex Crimp	Gold	Nickel	Polyethelene	Commercial	<b>29.46</b> 1.160	58425-2	—	<b>1-5413589-0</b>
	O Crimp	Gold	Nickel	Polyethelene	Commercial	<b>27.69</b> 1.090	58174-1	58248-3	<b>1-5221185-8</b>
BELDEN 8218	Hex Crimp	Gold	Nickel	Polyethelene	Commercial	<b>29.46</b> 1.160	58425-2	—	<b>5413589-3</b>
	O Crimp	Gold	Nickel	Polyethelene	Commercial	<b>27.69</b> 1.090	58174-1	58248-3	<b>5221185-3</b>
140, 210, 62, 62A, 62B, 59, 59A, 59B, BELDEN 9291, 9209, 9269	Hex Crimp	Gold	Nickel	Polyethelene	Commercial	<b>29.46</b> 1.160	58425-1	—	<b>5413589-2</b>
	O Crimp	Gold	Nickel	Polyethelene	Commercial	<b>27.69</b> 1.090	58536-1	58248-2	<b>5221185-2</b>
302, BELDEN 89269, 88241, Hi-Temp 62A, Times PL-62, Berk Tek BTDC-59, BTDC-62	Hex Crimp	Gold	Nickel	Polyethelene	Commercial	<b>29.46</b> 1.160	58425-1	—	<b>5413589-1</b>
	O Crimp	Gold	Nickel	Polyethelene	Commercial	<b>27.69</b> 1.090	58536-1	58248-2	<b>5221185-9</b>
BELDEN 8212, 9104, 9112, 9167, 9240, 9259, 9266, Times FM-59, (RG 59 Type with 20 AWG C.C.)	Hex Crimp	Gold	Nickel	Polyethelene	Commercial	<b>29.46</b> 1.160	58425-1	—	<b>5413589-7</b>
	O Crimp	Gold	Nickel	Polyethelene	Commercial	<b>27.69</b> 1.090	58536-1	—	<b>1-5221185-0</b>
BELDEN 9145, AT&T 734A	Hex Crimp	Gold	Nickel	Polyethelene	Commercial	<b>29.46</b> 1.160	58425-1	—	<b>5413589-7</b>
	O Crimp	Gold	Nickel	Polyethelene	Commercial	<b>27.69</b> 1.090	58536-1	—	<b>1-5221185-0</b>
BELDEN 9248, 9114	O Crimp	Gold	Nickel	Polyethelene	Commercial	<b>25.65</b> 1.010	58536-1	—	<b>5221185-1</b>
6, 6A	O Crimp	Gold	Nickel	Polyethelene	Commercial	<b>37.85</b> 1.490	58538-1	58248-1	<b>5221185-7</b>
BELDEN 8281, 9141, 9231, Western Electric 724, 728, 3049	Hex Crimp	Gold	Nickel	Polyethelene	Commercial	<b>29.46</b> 1.160	58425-3	—	<b>5413589-5</b>
	O Crimp	Gold	Nickel	Polyethelene	Commercial	<b>28.45</b> 1.120	58538-1	58248-1	<b>5221185-5</b>
COMM/SCOPE S59 Hec	O Crimp	Gold	Nickel	Polyethelene	Commercial	<b>28.96</b> 1.140	58536-1	—	<b>2-5221185-9</b>
COMM/SCOPE F59 Hec-z	O Crimp	Gold	Nickel	Polyethelene	Commercial	<b>28.96</b> 1.140	58536-1	—	<b>3-5221185-1</b>

AT&T is a trademark of AT&T Corporation.  
 BELDEN is a trademark of Belden Wire and Cable Company.  
 COMM/SCOPE is a trademark of Commscope, Inc.

**Note:** Part Numbers are RoHS compliant except: ♦ Indicates non-RoHS compliant.

**BNC Connectors, 75 Ohm** (Continued)

**Plugs for JIS Cables, Crimp**

**Plating**

**Body** — Nickel  
**Center Contact** — Gold



JIS Cable	Termination Type	Dielectric	Dim. L	Interchangeable Dies for PRO-CRIMPER Hand Tool 354940-1 or PRO-CRIMPER Adapter 679304-1	Part No.
3C-2V	Hex Crimp	Polymethylpentene	29.46 1.160	58425-1	1-5413589-1
2.5C-2V	Hex Crimp	Polymethylpentene	29.46 1.160	58425-2	1-5413589-6

**Bulkhead Jacks for JIS Cables, Crimp**

**Plating**

**Body** — Nickel  
**Center Contact** — Gold  
**Dielectric** — Polymethylpentene

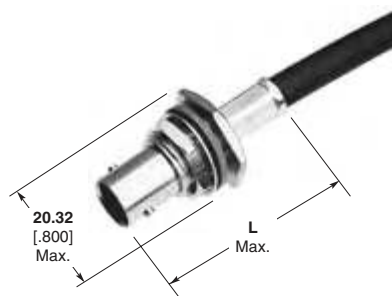

JIS Cable	Termination Type	Dielectric	Dim. L	Interchangeable Dies for PRO-CRIMPER Hand Tool 354940-1 or PRO-CRIMPER Adapter 679304-1	Part No.
1.5C-2V	Hex Crimp	75Ω	36.83 1.450	58425-2	5413590-4*

\*Packaged in 100 pieces per bag.

**Note:** Part Numbers are RoHS compliant except: ♦ Indicates non-RoHS compliant.

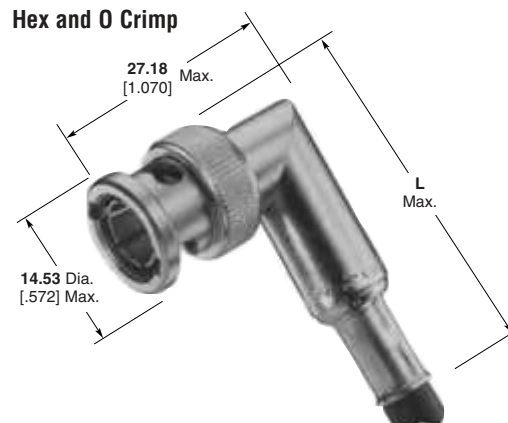
**BNC Connectors, 75 Ohm (Continued)**
**Right-Angle Plugs, Crimp**

RG/U Cable	Termination Type	Center Contact Plating	Body Plating	Dielectric	Style	Dim. L	Interchangeable Dies for PRO-CRIMPER Hand Tool 354940-1 or PRO-CRIMPER Adapter 679304-1	Interchangeable Dies for Hand Tool 69710-1 & 626 Pneu. Head 318161-1	Part No.
179, 179A, 179B, 187, 187A, 161 BELDEN 9221	Hex Crimp	Gold	Nickel	Polymethyl-pentene	Commercial	<b>39.45</b> 1.553	58425-2	—	<b>5413588-8</b>
AT&T 735A	Hex Crimp	Gold	Nickel	Polymethyl-pentene	Commercial	<b>39.45</b> 1.553	58425-2	—	<b>1-5413588-0</b>
AT&T KS 19224 L2, RD179 Double Braid	Hex Crimp	Gold	Nickel	Polymethyl-pentene	Commercial	<b>39.45</b> 1.553	58425-2	—	<b>5413588-4</b>
140, 210, 62, 62A, 62B, 59, 59A, 59B, BELDEN 9291, 9209, 9269	Hex Crimp	Gold	Nickel	Polymethyl-pentene	Commercial	<b>39.45</b> 1.553	58425-1	—	<b>5413588-2</b>
	O Crimp	Gold	Nickel	Polymethyl-pentene	Commercial	<b>39.88</b> 1.570	58536-1	58248-2	<b>5221402-2</b>
BELDEN 8212, 9104, 9112, 9240, 9167, 9259, 9266, Times FM-59, (RG 59 Type with 20 AWG C.C.)	Hex Crimp	Gold	Nickel	Polymethyl-pentene	Commercial	<b>39.45</b> 1.553	58425-1	—	<b>5413588-9</b>
BELDEN 9145, AT&T 734A	O Crimp	Gold	Nickel	Polymethyl-pentene	Commercial	<b>39.88</b> 1.570	58536-1	—	<b>5221402-4</b>

AT&T is a trademark of AT&T Corporation.  
BELDEN is a trademark of Belden Wire and Cable Company.

**Note:** Part Numbers are RoHS compliant except: ♦ Indicates non-RoHS compliant.



**BNC Connectors, 75 Ohm (Continued)**

**Jacks, Crimp**

**Hex and O Crimp**



RG/U Cable	Termination Type	Center Contact Plating	Body Plating	Dielectric	Style	Dim. L	Interchangeable Dies for PRO-CRIMPER Hand Tool 354940-1 or PRO-CRIMPER Adapter 679304-1	Interchangeable Dies for Hand Tool 69710-1 & 626 Pneu. Head 318161-1	Part No.
179, 179A, 179B, 161, 187, 187A, BELDEN 9221	Hex Crimp	Gold	Nickel	Polyethylene	Commercial	<b>33.02</b> 1.300	58425-2	—	<b>5413760-8</b>
	O Crimp	Gold	Nickel	Polyethylene	Commercial	<b>30.48</b> 1.200	318451-2	—	<b>5221199-5</b>
BELDEN 8218	Hex Crimp	Gold	Nickel	Polyethylene	Commercial	<b>33.02</b> 1.300	58425-2	—	<b>5413760-3</b>
140, 210, 62, 62A, 62B, 59, 59A, 59B, BELDEN 9291, 9209, 9269	O Crimp	Gold	Nickel	Polyethylene	Commercial	<b>30.48</b> 1.200	58536-1	58248-2	<b>5221199-2</b>
302, BELDEN 88241, 89269, Hi-Temp 62A, Times PL-62, Berk Tek BTDC-59, BTDC-62	Hex Crimp	Gold	Nickel	Polyethylene	Commercial	<b>33.02</b> 1.300	58425-1	—	<b>5413760-1</b>
BELDEN 8212, 9104, 9112, 9240, 9167, 9259, 9266, Times FM-59, (RG 59 Type with 20 AWG C.C.)	Hex Crimp	Gold	Nickel	Polyethylene	Commercial	<b>33.02</b> 1.300	58425-1	—	<b>5413760-9</b>
BELDEN 9248, 9114	O Crimp	Gold	Nickel	Polyethylene	Commercial	<b>30.48</b> 1.200	58536-1	—	<b>5221199-1</b>

BELDEN is a trademark of Belden Wire and Cable Company.

**Note:** Part Numbers are RoHS compliant except: ♦ Indicates non-RoHS compliant.

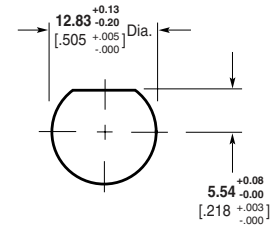
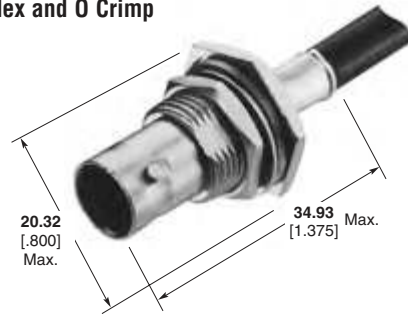
**BNC Connectors, 75 Ohm (Continued)**
**Bulkhead Jacks, Crimp**
**Hex and O Crimp**

Maximum Panel Thickness 6.1 [0.240]

**Recommended Panel Cutout**

RG/U Cable	Termination Type	Center Contact Plating	Body Plating	Dielectric	Style	Dim. L	Interchangeable Dies for PRO-CRIMPER Hand Tool 354940-1 or PRO-CRIMPER Adapter 679304-1	Interchangeable Dies for Hand Tool 69710-1 & 626 Pneu. Head 318161-1	Part No.
179, 179A, 179B, 161, 187, 187A, BELDEN 9221	Hex Crimp	Gold	Nickel	Polyethelene	Commercial	<b>36.83</b> 1.450	58425-2	—	<b>5413590-8</b>
	O Crimp	Gold	Nickel	Polyethelene	Commercial	<b>34.93</b> 1.375	318451-2	—	<b>5221221-5</b>
AT&T KS 19224 L2, RD179 Double Braid	Hex Crimp	Gold	Nickel	Polyethelene	Commercial	<b>36.83</b> 1.450	58425-2	—	<b>5413590-4</b>
BELDEN 8218	Hex Crimp	Gold	Nickel	Polyethelene	Commercial	<b>36.83</b> 1.450	58425-2	—	<b>5413590-3</b>
140, 210, 62, 62A, 62B, 59, 59A, 59B, BELDEN 9291, 9209, 9269	O Crimp	Gold	Nickel	Polyethelene	Commercial	<b>34.93</b> 1.375	58536-1	58248-2	<b>5221221-2</b>
BELDEN 8212, 9104, 9112, 9240, 9167, 9259, 9266, Times FM-59 (RG 59 Type with 20 AWG C.C.)	O Crimp	Gold	Nickel	Polyethelene	Commercial	<b>34.93</b> 1.375	58536-1	58248-2	<b>5221221-7</b>
BELDEN 9114, 9248	O Crimp	Gold	Nickel	Polyethelene	Commercial	<b>34.93</b> 1.375	58536-1	—	<b>5221221-1</b>

AT&T is a trademark of AT&T Corporation.  
 BELDEN is a trademark of Belden Wire and Cable Company.

**Note:** Part Numbers are RoHS compliant except: ♦ Indicates non-RoHS compliant.

**BNC Connectors, 75 Ohm (Continued)**

**Bulkhead Solder Jacks  
Front Mount**

**Plating**

**Body** — Nickel

**Center Contact** — Silver

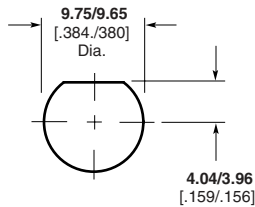

Maximum Panel Thickness **3.18** [.125]

**Recommended Panel Cutout**

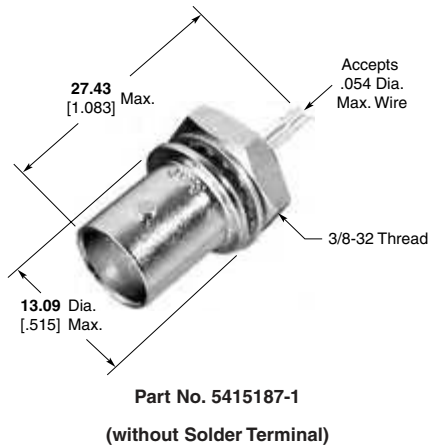

**Note:** If insulating bushing required use part no. 227223-1 or 221951-1 (for details, reference page 55).

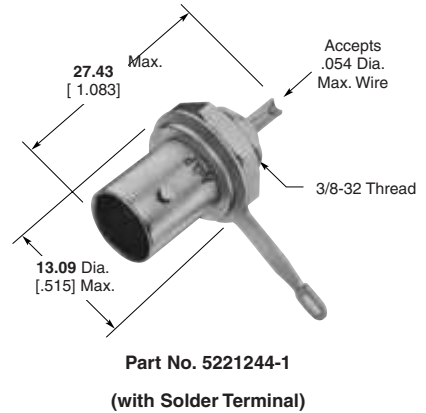

**Note:** If insulating bushing required use part no. 227223-1 or 221951-1 (for details, reference page 55).

**Bulkhead Jack  
PC Board Mount**

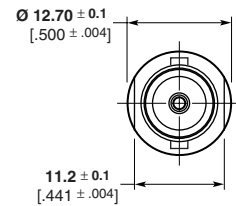
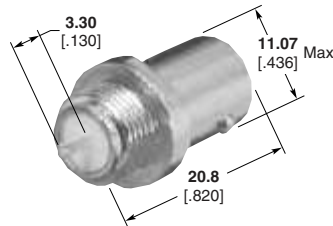

**Bulkhead Solder Jack  
Rear Mount**

Lockwasher and Jam Nut see page 73.

**Plating**

**Body** — Nickel

**Center Contact** — Gold

**Dielectric** — Polymethylpentene

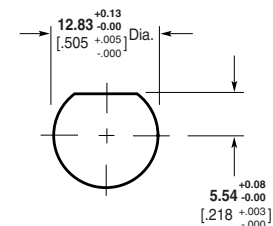
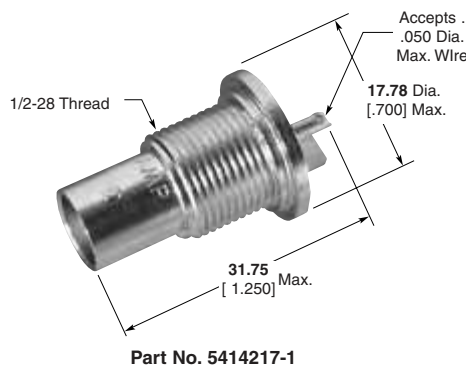

Maximum Panel Thickness **6.35** [.250]

**Recommended Panel Cutout**

**Note:** Part Numbers are RoHS compliant except: ♦ Indicates non-RoHS compliant.

**BNC Connectors, 75 Ohm (Continued)**

**Right-Angle Jacks  
PC Board/Panel Mount**

**Outer Shell** — Nickel  
**Dielectric** — Polymethylpentene  
Lockwasher and Jam Nut see page 73.

**VALOX Body**

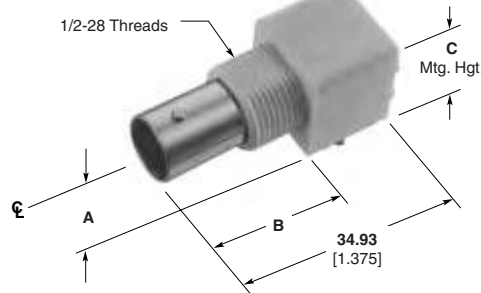

**Metal Body**

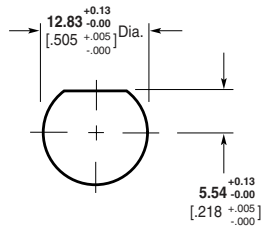
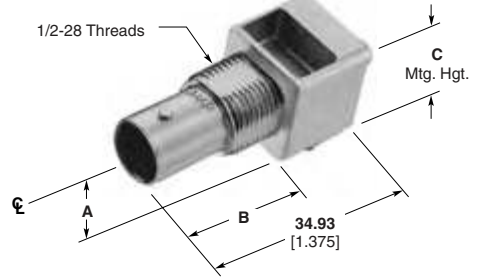

Maximum Panel Thickness 6.1 [240]

**Recommended Panel Cutout**

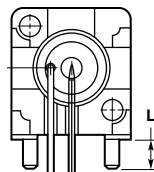

**Recommended PC Board Layouts**

**Without Mounting Posts**

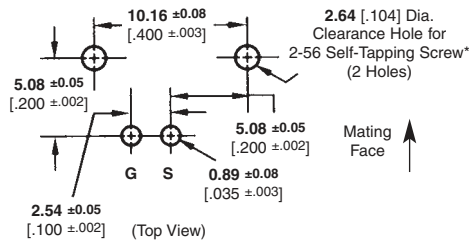

**With Mounting Posts**

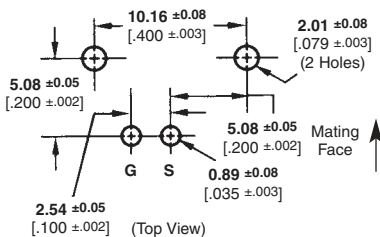

\* Screw for panel thickness of **2.38** [3/32] or greater  
**Part No. 221108-2.**  
Screw for panel thickness of less than **2.38** [3/32]  
**Part No. 221108-4.**

Body Material	Center Contact Plating	Dimensions				Part No.	
		A	B	C	L	Without Mounting Posts	With Mounting Posts
VALOX, Black w/ Compliant Posts (Economy)*	Gold3	6.17 .243	21.21 .835	11.68 .460	2.79 .110	—	5415105-2
VALOX, Black (Economy)*	Gold3	6.17 .243	21.21 .835	11.68 .460	4.01 .158	—	5415105-1
VALOX, White	Gold1	6.91 .272	21.21 .835	13.88 .519	3.48 .137	—	5413194-1
VALOX, White (Economy)*	Gold1	6.91 .272	21.21 .835	13.88 .519	3.48 .137	—	5415634-2
VALOX, Black	Gold1	6.91 .272	21.21 .835	13.88 .519	3.48 .137	—	5413194-2
VALOX, Black (Economy)*	Gold1	6.91 .272	21.21 .835	13.88 .519	3.48 .137	—	5415634-1
VALOX, Black (Economy)*	Gold1	8.59 .338	21.21 .835	15.88 .625	3.48 .137	—	5415633-1
VALOX, White	Gold2	8.59 .338	21.21 .835	15.88 .625	3.48 .137	—	5414459-1
Metal	Gold1	8.25 .325	20.83 .820	15.88 .625	2.16 .085	—	5222092-1
Metal	Gold1	8.25 .325	20.83 .820	15.88 .625	—	5222093-1	—
Metal (Economy)*	Gold1	8.25 .325	20.83 .820	15.88 .625	3.48 .137	—	5414409-1
Metal with Compliant Posts (Economy)*	Gold1	6.91 .272	20.83 .820	12.70 .500	3.48 .137	—	5415417-1
Metal with Compliant Posts (Economy)*	Tin	8.56 .337	21.21 .835	15.88 .625	3.48 .137	—	5415419-1
Metal	Gold1	8.25 .325	20.83 .820	15.88 .625	3.48 .137	—	5222092-3
Metal	Gold1	6.91 .272	20.83 .820	12.70 .500	3.48 .137	—	5414907-1
Metal	Gold1	6.91 .272	20.83 .820	12.70 .500	—	6274072-1	—
Metal (Economy)*	Gold1	6.91 .272	20.83 .820	12.70 .500	3.48 .137	—	6274084-1

\*Economy connector uses 50 Ω part with smaller dielectric and stamped and formed contact, Phosphor Bronze contact material (Compare to regular connector which is 75 Ω, screw machined Beryllium Copper).

**Plating:**

Gold1 — 0.00076 [0.000030] thick  
Gold2 — 0.00127 [0.000050] thick

**Note:** If an Insulating Bushing is required see part number 330620 and Panel Cutout on page 54.

VALOX is a trademark of General Electric Company.

**Note:** Part Numbers are RoHS compliant except: ♦ Indicates non-RoHS compliant.

**BNC Connectors, 75 Ohm (Continued)**

**Vertical Jacks  
PC Board/Panel Mount**

**Plating**

**Outer Shell** — Nickel

**Dielectric** — Polymethylpentene

**VALOX Body**

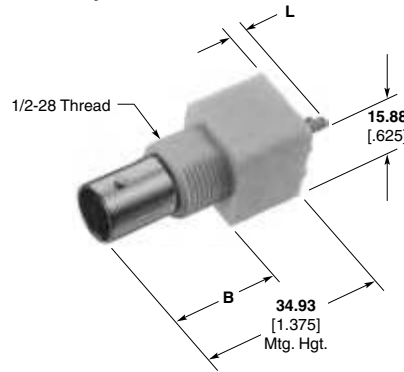

**Metal Body**

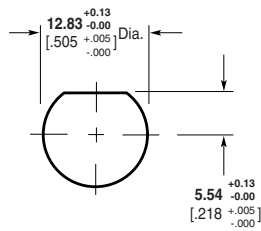
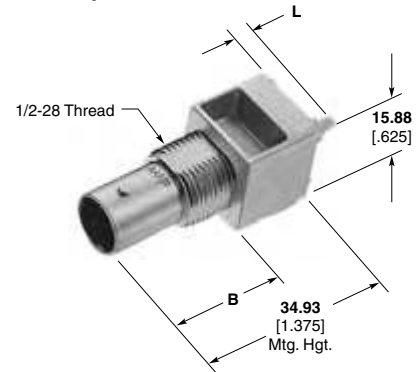

Maximum Panel Thickness 6.1 [.240]

**Recommended Panel Cutout**

Body Material	Contact Plating	Dim. B	Dim. L	Part No.
VALOX, Black (Economy)*	Gold1	21.21 .835	3.48 .137	5415632-1
VALOX, White (Economy)*	Gold1	21.21 .835	3.48 .137	5415632-2
Metal	Gold1	20.83 .820	3.48 .137	5222132-1
Metal (Economy)*	Tin	21.21 .835	3.48 .137	5415520-1

\*Economy connector uses 50 Ω part with smaller dielectric and stamped and formed contact, Phosphor Bronze contact material (Compare to regular connector which is 75 Ω, screw machined Beryllium Copper).

**Plating:**

Gold1 — 0.00076 [.000030] thick

**Note:** If an Insulating Bushing is required see part number 330620 and Panel Cutout on page 54.

**Lockwasher and Jam Nut**



Part No.  
1-329632-2



Part No.  
1-329631-2

\* Screw for panel thickness of 2.38 [3/32] or greater

Part No. 221108-2.

Screw for panel thickness of less than 2.38 [3/32]

Part No. 221108-4.

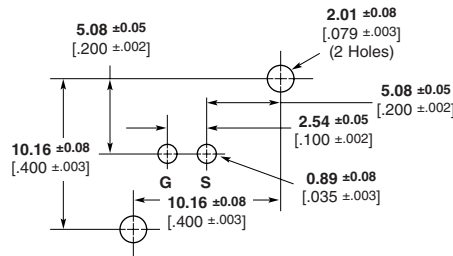

(Top View)

**Recommended PC Board Layout**

VALOX is a trademark of General Electric Company.

**Note:** Part Numbers are RoHS compliant except: ♦ Indicates non-RoHS compliant.

**BNC Connectors, 75 Ohm (Continued)**

**Vertical Metalized Jacks  
PC Board Mount**

**Plating**  
Dielectric — PTFE

**Style A**

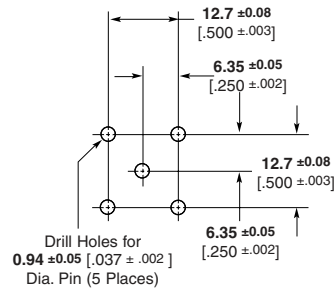
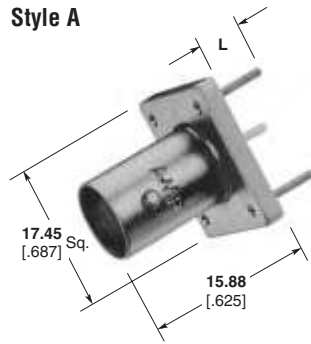

**Style B**

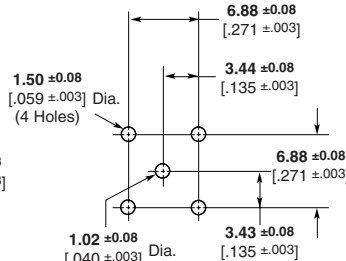

**Style C**

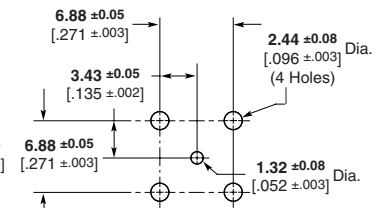
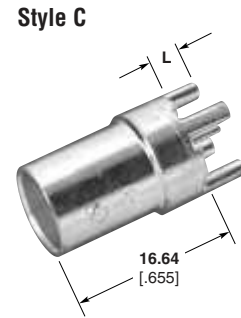

**Recommended PC Board Layout**

**Style F (Push-On)**

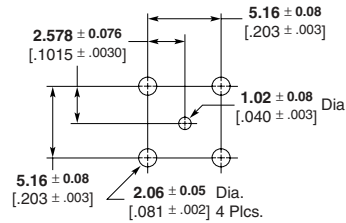
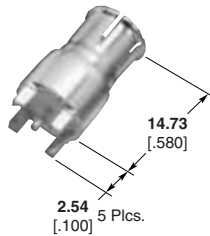

Body Plating	Center Contact Plating	Style	Leg Length L	Part No.
Nickel	Gold	B	3.30 .130	6274291-2
Tin	Gold	B	3.30 .130	6274291-1
Tin	Gold	B	6.35 .250	6274359-1
Tin	Gold	C	4.44 .175	5414394-1
Nickel	Silver	A	6.35 .250	5413986-1
Tin	Gold	F	2.54 .100	6274360-1

**Press Fit  
Vertical Metalized Jacks  
PC Board Mount**

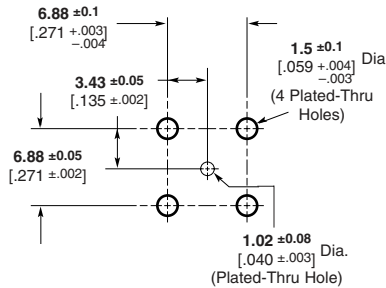
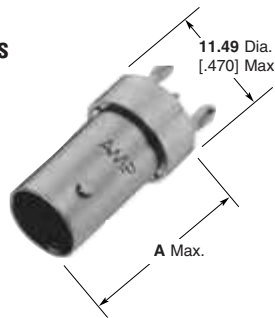

**Recommended PC Board Layout**

Dim. A	Part No.
20.57 .810	5222462-1
16.26 .640	5414088-1

**Insulating Bushing**

**Material** — Nylon  
**Part No.** 222163-1  
Only to be used on Part Nos.  
5222462-1 and 5222006-1

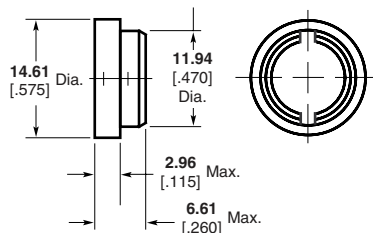

**Note:** Part Numbers are RoHS compliant except: ♦ Indicates non-RoHS compliant.

**BNC Connectors, 75 Ohm (Continued)**

**Press Fit Vertical Metalized Jacks PC Board Mount**  
(Continued)

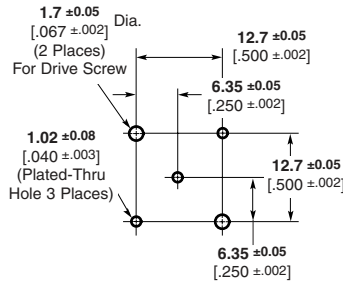
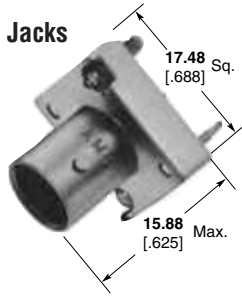

**Recommended PC Board Layout**

PC Board Thickness (Min.)	Part No.
2.36 .093	5221336-3
3.17 .125	5221336-4

**Press Fit, Bulkhead Vertical Metalized Jack includes hardware**

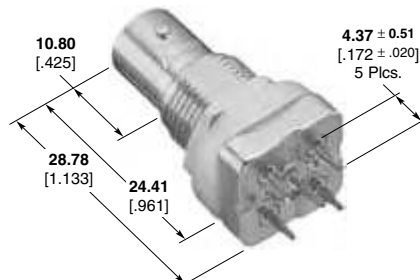

**Part No. 6274124-2**

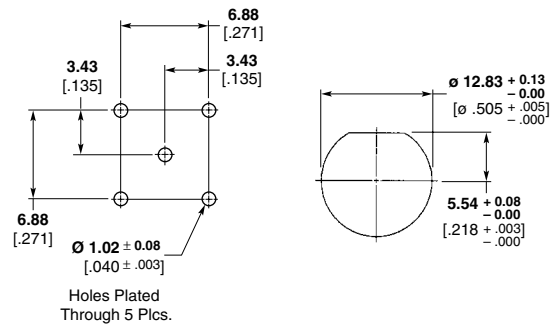

**Recommended PC Board Layout**

**Right-Angle Metalized Jacks PC Board Mount**

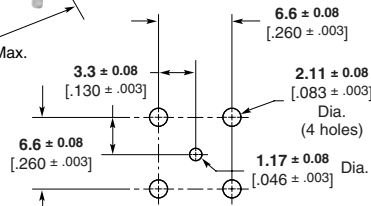
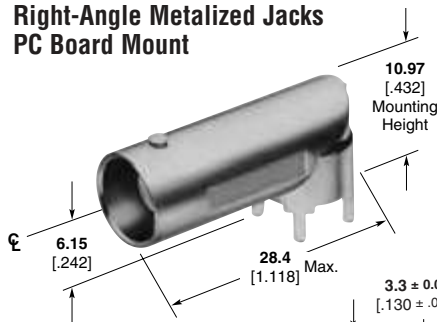

Maximum PC Board Thickness 2.54 [.100]

**Recommended PC Board Layout**

Body Plating	Dielectric	Contact Plating	Center Contact Dimension	Part No.
Nickel	TPX	Gold2	.171 [.007]	5413558-1
Tin	PTFE	Gold2	.171 [.007]	5413558-2
Nickel	TPX	Gold2	.131 [.005]	5413558-3
Nickel	TPX	Gold1	.171 [.007]	5413558-5

Gold1—0.00076 [.000030] thick  
Gold2—0.00127 [.000050] thick

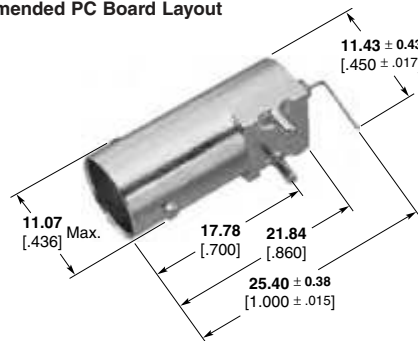

**Part No. 6274127-1**

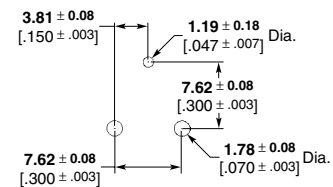

TPX is a trademark of Mitsui Chemicals America, Inc.

**Note:** Part Numbers are RoHS compliant except: ♦ Indicates non-RoHS compliant.



**BNC Connectors, 75 Ohm (Continued)**

**Right-Angle Metalized  
Jacks  
PC Board/Panel Mount**

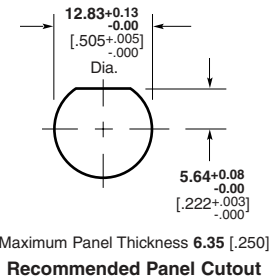
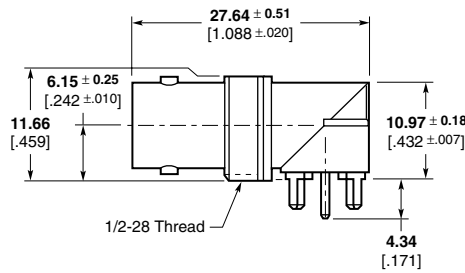

Body Plating	Dielectric	Part No.
Tin	PTFE	6274425-2

**Bulkhead Jack-Jack  
Adapter**

**Plating**

**Body** — Nickel  
**Center Contact** — Gold  
**Dielectric** — Polymethylpentene

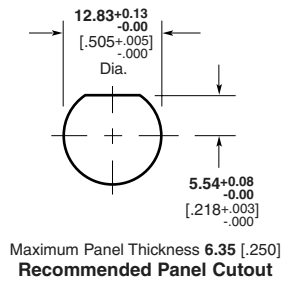
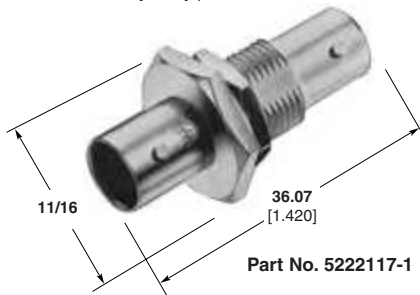

**Right-Angle Adapter  
(Jack-Plug)**

**Plating**

**Body** — Nickel  
**Center Contact** — Gold  
**Dielectric** — Polymethylpentene

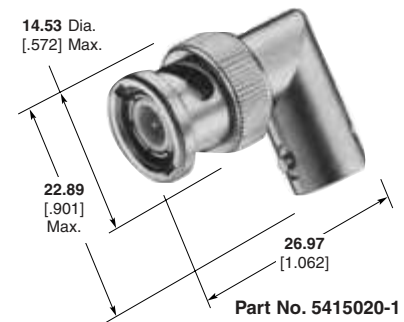

**Bulkhead Jack-Jack  
Adapter**

**Plating**

**Body** — Nickel  
**Center Contact** — Gold  
**Dielectric** — Polymethylpentene

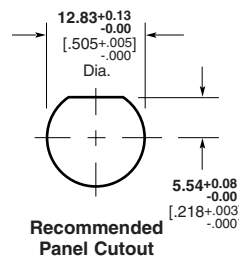
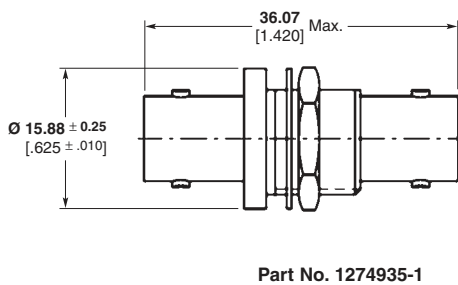

**Jack-Jack Adapter**

**Plating**

**Body** — Nickel  
**Center Contact** — Gold  
**Dielectric** — Polymethylpentene

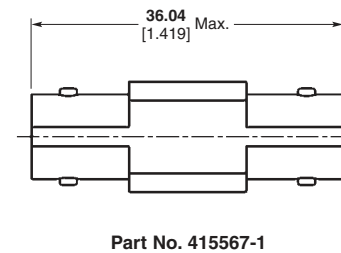

**Note:** Part Numbers are RoHS compliant except: ♦ Indicates non-RoHS compliant.

**BNC Connectors, 75 Ohm (Continued)**

**Bulkhead Jack-Push On Plug Adapter**

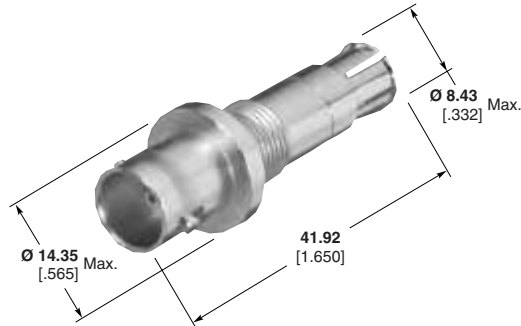

Part No. 1274007-1

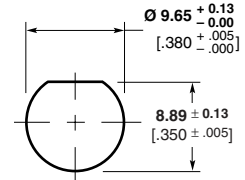

Recommended Panel Cutout

**Note:** Part Numbers are RoHS compliant except: ♦ Indicates non-RoHS compliant.

## Mini BNC Connectors, 75 Ohm

### Product Facts

- Bayonet locking coupling mechanism
- 40% more interconnects in the same area
- Compatible with TROMPETER tooling
- Ideal for telecommunications and broadband applications



Tyco Electronics introduces the Mini BNC series of RF connectors to meet the growing demand for next generation telecommunications and broadband applications where higher connector densities are needed. Preserving the characteristics that have made the standard BNC so popular, the Mini BNC offers the same high performance currently found in standard Tyco Electronics BNC series, but offers 40% more interconnects in the same area.

The Mini BNC offering is an excellent fit for 75 Ohm systems, offering 500 mating cycles, electrical performance through 2 GHz, and is completely intermateable with competitive miniature BNC offerings. Tyco Electronics' Mini BNC product offers the same advantage of the bayonet locking mechanism as our standard BNC, allowing quicker connect and disconnects than standard

threaded interfaces. It uses standard BNC installation tooling meaning there is no need for retraining of field telco installers, and it utilizes the same PCB footprint on the jack side, providing a drop in replacement for DS3 telco applications.

Mini BNC connector configurations currently available include PCB, panel mount, and flexible cable. Other options can be reviewed as well, including additional cable sizes, adapters, PCB surface mounting, and tape and reel packaging. Call your local sales office or authorized distributor for additional information or samples of the Mini BNC connector series.

Tyco Electronics is a leading supplier of RF and Microwave connectors and cable assemblies, and provides advanced technology products from well known and industry leading brands, including AMP and M/A-COM.

### Material and Finish

**Shells, Bodies, Mtg Nuts** — Brass, nickel plated

**Washers** — Stainless Steel, nickel plated

**Ferrule** — Copper or Brass, tin plated

**Center Contacts** — Phos Bronze and Brass, gold plated

**Dielectrics** — PTFE

### Electrical Characteristics

**Frequency** — DC – 2 GHz

**Nominal Impedance** — 75 ohms

**Voltage Rating** — 300 Volts (VRMS maximum) @ Sea Level

**VSWR** —

1.10 max to 500 MHz  
(Return Loss -26.4 dB)

1.16 max to 1 GHz  
(Return Loss -22.6 dB)

**Insulation Resistance** —

1,000 megohms minimum

**Dielectric Withstanding Voltage** —

1,000 Volts (VRMS maximum) @ Sea Level

**Contact Resistance** —

12 milliohms maximum

### Mechanical Characteristics

**Connector Durability** —

500 mating cycles

**Force to Engage** —

7 pounds maximum

**Force to Disengage** —

1 pound minimum

**Center Contact Retention** —

2 pounds minimum

**Cable Retention** —

20 pounds minimum

**Vibration** — EIA-364-28,

Test Condition VII, Condition D

**Shock** — EIA-364-27, Method H

### Environmental Characteristics

**Temperature Rating** —

-40 to +85°C

**Moisture Resistance** — EIA-364-31,  
Method II, Condition C

**Thermal Shock** — EIA-364-32

**Note:** Performance specifications are typical, but may not apply to all connector types.

### Related Product Data

**Product Specification** — 108-2159

**Sample Kit** — 1773042

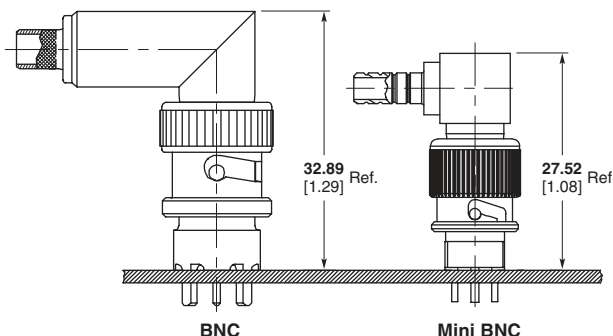

TROMPETER is a trademark of Trompeter Electronics, Inc.

**Mini BNC Connectors, 75 Ohm (Continued)**

**Interface Dimensions**

**Mini BNC Jack**

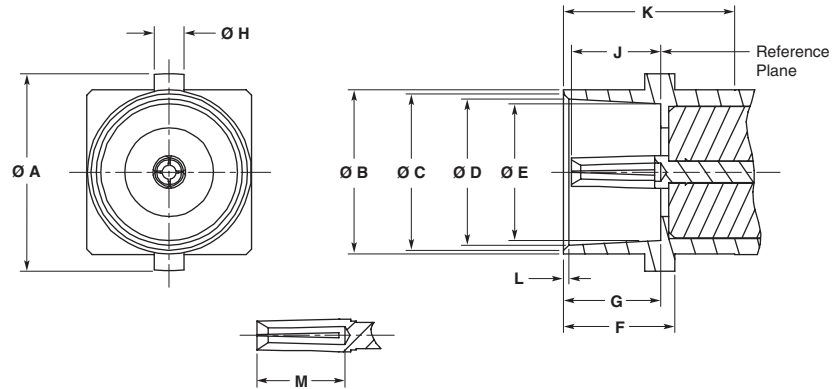

Dimensions											
A	B	C	D	E	F	G	H	J	K	L	M
8.89–9.14	7.37–7.62	7.11–7.21	6.63–6.73	6.20–6.30	5.03–5.13	4.39–4.50	1.32–1.42	3.86–4.27	7.70	0.18–0.30	4.01
.350–.360	.290–.300	.280–.284	.261–.265	.244–.248	.198–.202	.173–.177	.052–.056	.152–.168	.303 Min.	.007–.012	.158 Min.

**Mini BNC Plug**

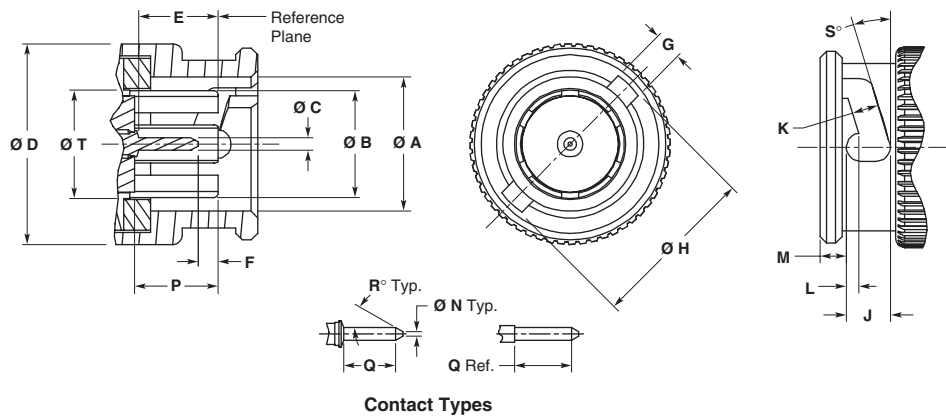

**Contact Types**

Dimensions									
A	B	C	D	E	F	G	H	J	
7.70–7.80	—	0.71–0.76	11.43–11.68	4.27–4.93	0.94–1.35	1.57–1.68	9.60–9.70	2.50–2.59	
.303–.307		.028–.030	.450–.460	.168–.194	.037–.053	.062–.066	.378–.382	.098–.102	

Dimensions									
K	L	M	N	P	Q	R	S	T	
1.57–1.68	0.64–0.74	1.47–1.57	0.20–0.30	4.62–4.93	2.84–3.38	29°–31°	14°–16°	6.20–6.30	
.062–.066	.025–.029	.058–.062	.008–.012	.182–.194	.112–.133			.244–.248	

**Mini BNC Connectors, 75 Ohm (Continued)**

**Flexible Cable — Crimp Attachment**

**Straight Cable Plug**

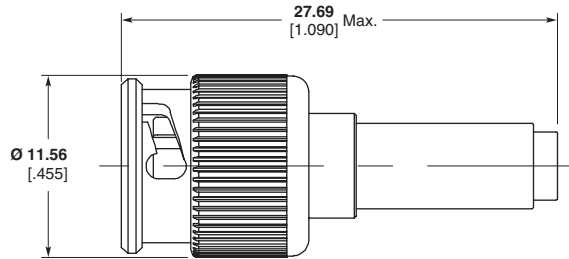

Cable	Part Number
735A	1274563-1
734A	1274563-2
RG 179	1274563-3

**Right-Angle Cable Plug**

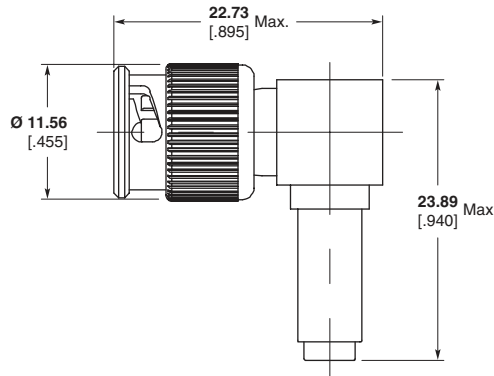

Cable	Part Number
735A	1274566-1
734A	1274566-2
RG 179	1274566-3

**Bulkhead Cable Jack**

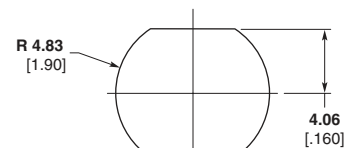
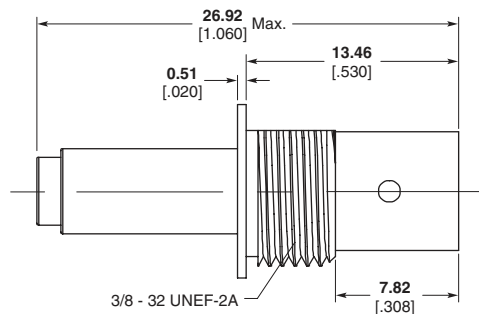

**Recommended Panel Cutout  
Tolerance: ± 0.08 [.003]**

Cable	Part Number
735A	1274568-1
734A	1274568-2
RG 179	1274568-3

**Note:** Part Numbers are RoHS compliant except: ♦ Indicates non-RoHS compliant.

**Mini BNC Connectors, 75 Ohm (Continued)**

**Printed Circuit Board  
Straight Jack Receptacle**

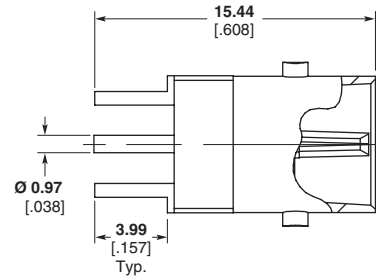
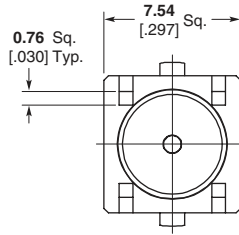

Part Number  
1274571-1

**Right-Angle Jack Receptacle**

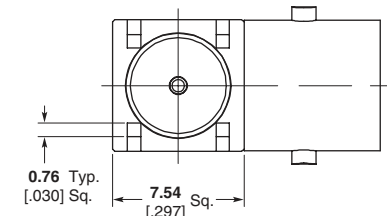
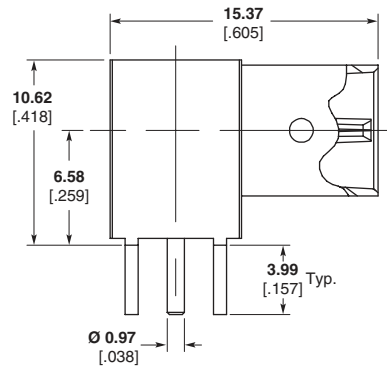

Part Number  
1274572-1

**Right-Angle Bulkhead Jack Receptacle**

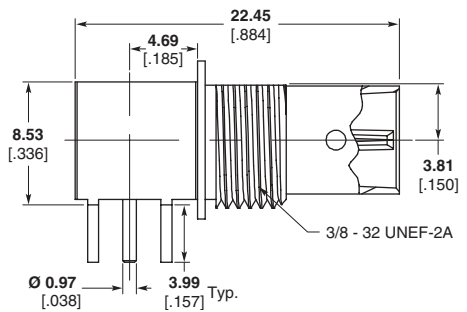
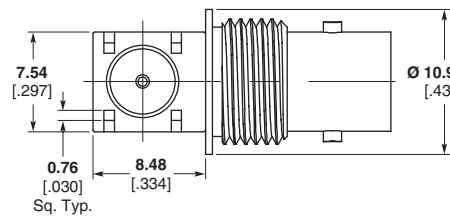

Part Number  
1274584-1

**2 Position, Right-Angle,  
Bulkhead Jack Receptacle**

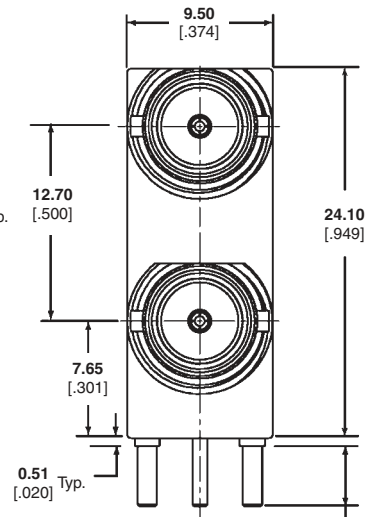
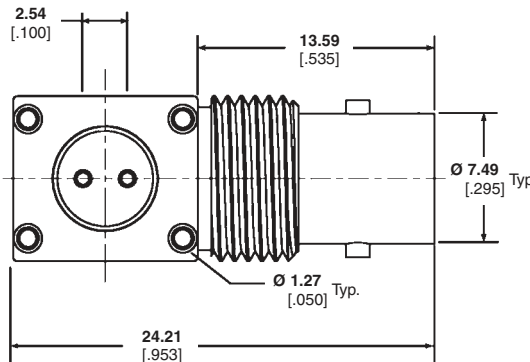

Description	Part Number
With Hardware	1274663-2
Without Hardware	1274684-1

**Note:** Part Numbers are RoHS compliant except: ♦ Indicates non-RoHS compliant.

## Decoupled Connectors

### Product Facts

- Built-in chip capacitors filter high-frequency noise to panel ground
- PC board mounting with vertical and standard or low-profile right-angle configurations
- Cable mount bulkhead BNC version available
- Drop-in replacement for Tyco Electronics standard BNC printed circuit board connectors
- One-piece design and robotic capacity to reduce assembly time



Tyco Electronics capacitively decoupled connectors provide the fast, better way to reduce noise and reduce ground loops on coaxial interconnections. The high-frequency noise generated by fast rise times can cause both false triggering of circuits as well as emissions that can be radiated or conducted outside the equipment. Such emissions can interfere with nearby equipment. Ground loops are also a problem for networked systems. Ground loops are caused when two interconnected units are at different voltage potentials.

The typical way to handle such EMI and ground loop problems is to decouple the cable shield from the ground panel by soldering a ceramic disk capacitor between the cable shield and the panel. The capacitor shunts high-frequency noise to ground. While effective, this approach is time consuming and expensive.

The Capacitively Decoupled connector has built-in chip capacitors. These capacitors establish the electrical contact between the outer shield and a clip. This clip provides a short electrical

path between the capacitors and panel. As a result, high-frequency noise is effectively shunted to ground, while the DC path is blocked.

The connectors offer compatibility in design and manufacture. The same footprint and dimensional envelope make them a drop-in replacement for Tyco Electronics standard BNC or TNC printed circuit board connectors. In addition, they can be robotically picked and placed for high-speed automated assembly to pc boards.

### Product Specification

108-1263 — BNC Decoupled PCB Press-Fit Connection

108-1269 — BNC Decoupled PCB Connectors

108-1490 — BNC Decoupled Cable Mount



**Decoupled Connectors** (Continued)

**PC Board/Panel Mount  
Jacks Decoupled to Panel**

**Style A  
Vertical BNC**

**Material**

**Body** — VALOX, black  
**Dielectric** — Polymethylpentene

**Note:** Both styles are shown with a standard clip. See next page for other clip styles.

For height dimensions see chart on page 85.

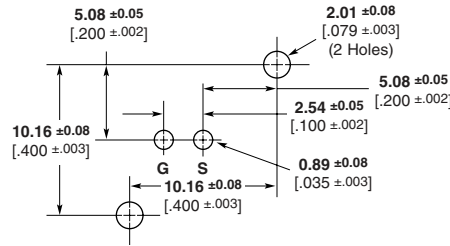
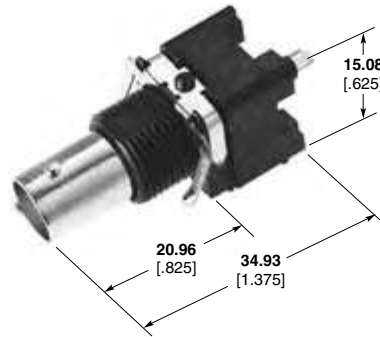

(Top View)

Recommended PC Board Layout

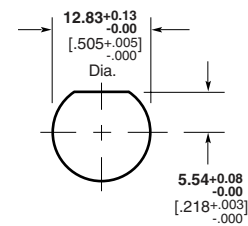

Maximum Panel Thickness 6.1 [0.240]  
Recommended Panel Cutout

**Style B  
Right-Angle BNC**

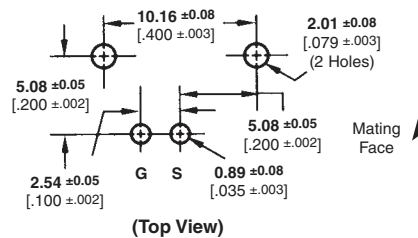
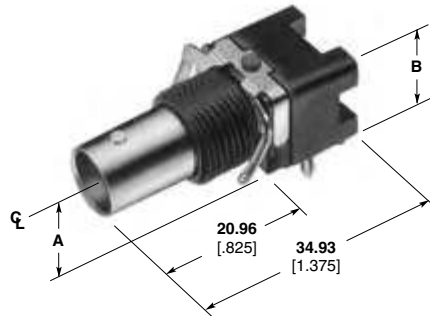

(Top View)

Recommended PC Board Layout

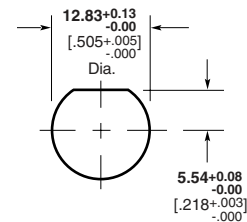

Maximum Panel Thickness 6.1 [0.240]  
Recommended Panel Cutout

VALOX is a trademark of General Electric Company.

**Decoupled Connectors** (Continued)

**Clip Styles**

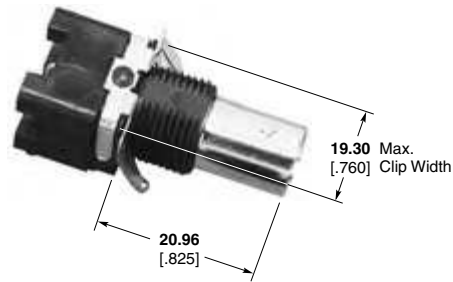

**Standard**

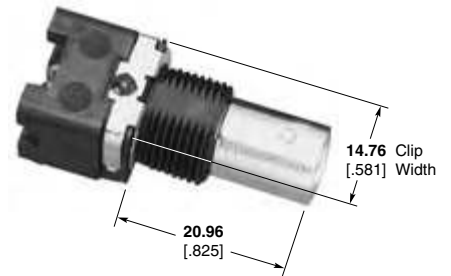

**Flush**

For closer centerline-to-centerline connector spacing

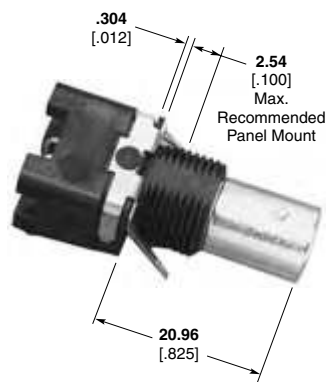

**Extended**

For use with or without a jam nut

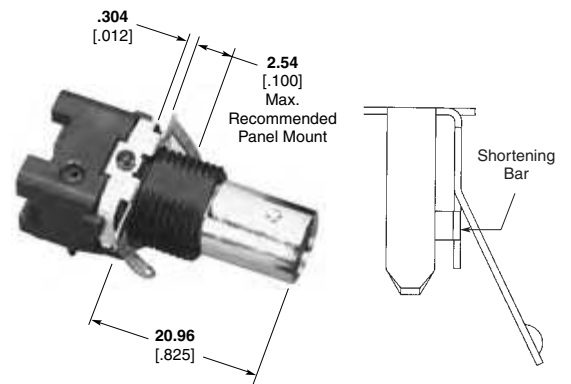

**Short Electrical Path**

For reduced series inductance in ground path

**Decoupled Connectors** (Continued)

**PC Board/Panel Mount  
Jacks Decoupled to Panel**

(Continued)

**Mounting Post Styles**

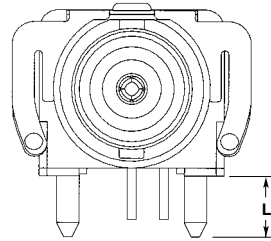

Standard

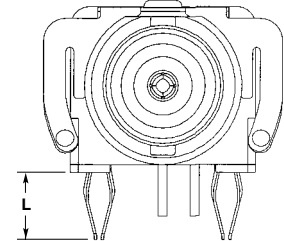

Compliant

**BNC**

Description	Capacitance/ Voltage	Clip	Mounting Post	L Mounting Post Length	B*	A*	Style <sup>1</sup>	Part No.
Vertical 50Ω	9400pF 1500VDC	Standard	Standard	3.48 .137	—	—	A	5413476-2
Standard Right-Angle 50Ω	9400pF 1500VDC	Standard	Standard	4.01 .158	15.88 .625	8.59 .338	B	5413524-2
	9400pF 1500VDC	Standard	Compliant	2.79 .110	15.88 .625	8.59 .338	B	5413524-5
Standard Right-Angle W/O Mounting Post 50Ω <sup>2</sup>	9400pF 1500VDC	Standard	—	—	15.88 .625	8.59 .338	B	5414215-1
Low Profile Right-Angle 50Ω	9400pF 1500VDC	Standard	Standard	4.01 .158	13.18 .519	6.91 .272	B	5413515-2
	20000pF 500VDC	Standard	Standard	4.01 .158	13.18 .519	6.91 .272	B	5413515-3
	7900pF 1600VDC	Standard	Compliant	2.79 .110	13.18 .519	6.91 .272	B	5413515-7
	9400pF 1500VDC	Standard	Compliant	4.70 .185	13.18 .519	6.91 .272	B	5413515-8
	9400pF 1500VDC	Standard	Compliant	2.79 .110	13.18 .519	6.91 .272	B	5413515-9
Low Profile Right- Angle W/Special Clip & High Temperature Housing 50Ω	9400pF 500VDC	Extended	Compliant	2.79 .110	13.18 .519	6.91 .272	B	5414284-2
Low Profile Right-Angle W/High Temperature Housing 50Ω	9400pF 500VDC	Flush	Compliant	4.70 .185	13.18 .519	6.91 .272	B	5414352-1
Low Profile Right-Angle 75Ω	9400pF 1500VDC	Standard	Standard	4.01 .158	13.18 .519	—	B	5414094-2
Ultra Low Profile Right-Angle 75 Ω	9400pF 1500VDC	Standard	Standard	4.01 .158	6.17 .243	11.68 .460	—	5415103-1
	9400pF 1500VDC	Standard	Compliant	2.79 .110	6.17 .243	11.68 .460	—	5415103-2

<sup>1</sup>See pages 83 and 84 for Connector Styles.

<sup>2</sup>See customer drawing for PC Board Layout.

\*See page 83 for dimension reference.

**Note:** Part Numbers are RoHS compliant except: ♦ Indicates non-RoHS compliant.

**Decoupled Connectors (Continued)**

**Right-Angle BNC Jack  
PC Board/Panel Mount  
Decoupled to Panel  
ESD Protected**

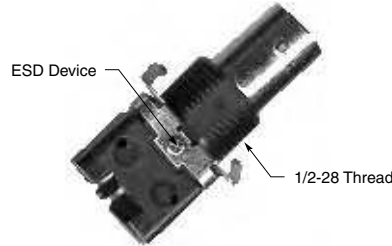

See page 83 Style B for panel cutout and recommended PC board configuration.

**Note:** See Tyco Electronics Customer drawing for voltage breakdown rating.

Description	Capacitance/ Voltage	Contact Plating	Clip	Mounting Post	L Mounting Post Length	B*	A*	Part No.
<b>50Ω Product</b>								
Low Profile Right-Angle W/ ESD Protection	7900pF 1500VDC	Gold1	Standard	Compliant	2.79 .110	13.18 .519	6.91 .272	5414651-3
<b>75Ω Product</b>								
Standard Right-Angle W/ ESD Protection	9400pF 1500VDC	Gold1	Standard	Standard	4.01 .158	15.88 .625	8.59 .338	5415085-1
Low Profile Right-Angle ESD Protected	9400pF 1500VDC	Gold1	Flush	Compliant	2.79 .110	13.18 .519	6.91 .272	5415216-1

\*See page 83 for dimension reference.

**Right-Angle BNC Jack  
PC Board/Panel Mount  
Decoupled to Board  
ESD Protected**

Capacitance	Voltage
9400pF	1500VDC

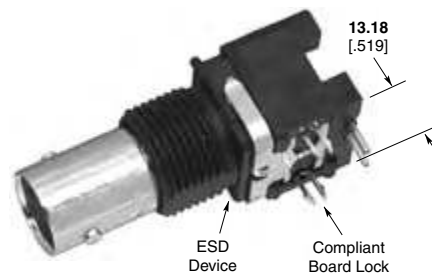

Part No. 5415205-1

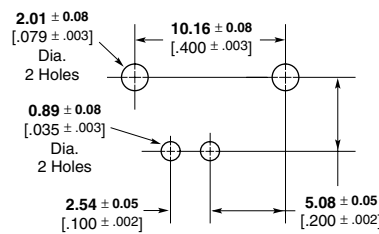

Recommended PC Board Layout

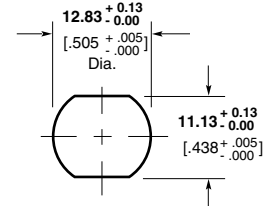

Recommended Panel Cutout

**Note:** Part Numbers are RoHS compliant except: ♦ Indicates non-RoHS compliant.

**Decoupled Connectors** (Continued)

**Press-Fit, Vertical BNC  
Jacks, PC Board Mount  
Decoupled to Board**

**Material**

**Dielectric**—PTFE  
**Isolation Pad**—Polyester

**Plating**

**Body**—Nickel  
**Ground Clip**—Nickel  
**Center Contact**—Gold  
**Action Pin Legs**—Gold

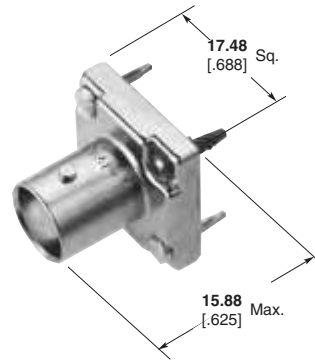

**Part No. 5414553-1 50 Ohm**  
**Part No. 5414493-4 75 Ohm**

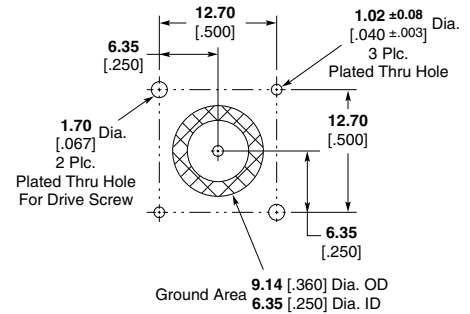

**Recommended PC Board Layout**

**BNC Bulkhead Jacks,  
Crimp**

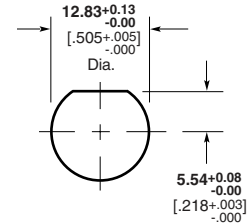
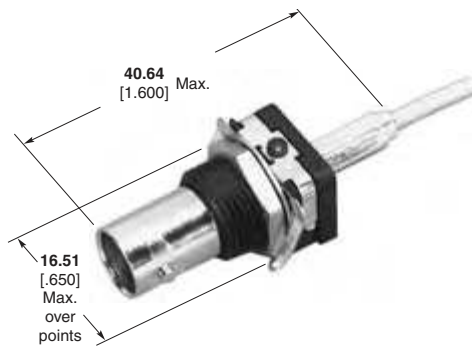

**Recommended Panel Cutout**

Description	RG/U Cable	Termination Type	Center Contact Plating	Body Plating	Dielectric	Style	Interchangeable Dies for Hand Tool 69710-1 & 626 Pneu. Head 318161-1	Part No.
50Ω	RG 58, 58A, 58B, 58C	Hex Crimp	Gold	Nickel	Polymethylpentene	Commercial	58436-1	<b>5414758-1</b>
50Ω	RG 174, 174A, 316, 188, 188A	Hex Crimp	Gold	Nickel	Polymethylpentene	Commercial	58436-3	<b>5414758-2</b>
50Ω	RG 174, 174A, 316, 188, 188A	Hex Crimp	Gold	Nickel	Polymethylpentene	Commercial	58436-3	<b>5414758-3</b>
75Ω ESD	RG 179, 187	Hex Crimp	Gold	Nickel	Polymethylpentene	Commercial	58425-2	<b>5415779-1</b>

**Note:** Part Numbers are RoHS compliant except: ♦ Indicates non-RoHS compliant.

## Self-Terminating PC Board Connectors

### Product Facts

- Built-in chip resistor terminates the signal line to the proper characteristic impedance when in the unmated state
- Can be ordered with standard resistance values (50, 75 and 100 Ohms)
- Fits into printed circuit board footprint of standard BNC PCB connectors
- One-piece design is compatible with robotic insertion and wave soldering

Tyco Electronics Self-Terminating printed circuit board BNC connectors provide the capability to automatically terminate an input-output port to the system characteristic impedance. This feature eliminates the need for external terminators when an I/O port is not being used. The Self-Terminating BNC jack contains a chip resistor which bridges the signal and ground paths when the connector is not mated to a BNC plug. When mated, the resistor is switched out of the circuit for direct signal transmission to the board.

The footprint of this connector is compatible with standard BNC connectors, allowing it to be easily installed into existing circuit board designs and suitable for robotic insertion for high speed automated assembly onto the PC board.

The Self-Terminating BNC is available in standard resistance values for use in networking and video systems. Contact Tyco Electronics for new designs that include switching and capacitively decoupled versions.

### Material

**Body** — Polyester, PBT, black  
**Dielectric** — Polyester, PBT, natural

### Plating

**Shell** — Tin  
**Center Contact** — Gold on mating end and Tin on solder tails

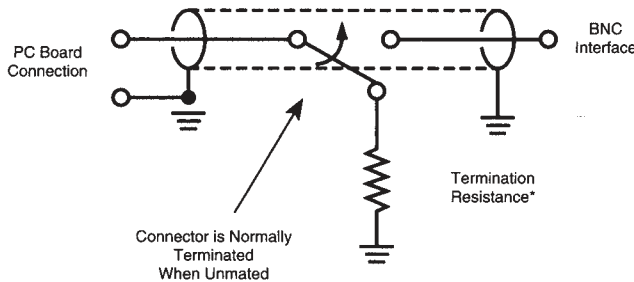
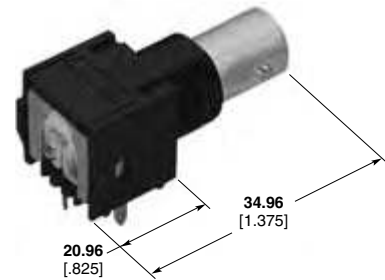
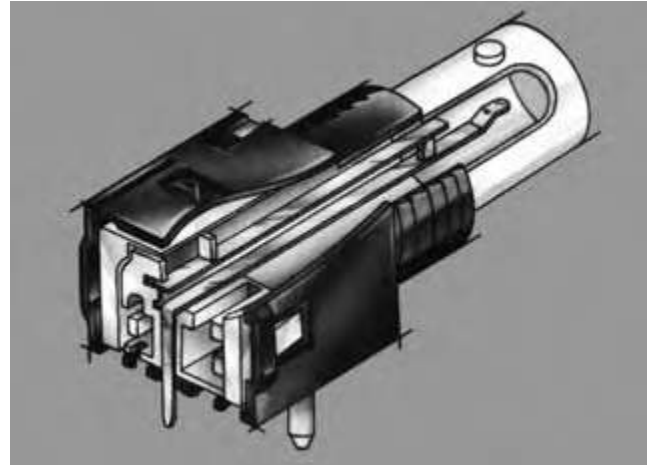

Product	Termination Resistance	Part Number
Self-Terminating BNC PCB	75Ω	5414367-2

**Note:** Part Numbers are RoHS compliant except: ♦ Indicates non-RoHS compliant.

## Twin BNC Connectors

### Product Facts

- Crimp connectors require only one-stroke crimping of both conductors, plus braid and cable support
- Lower installed cost with one-stroke crimp
- Reduced noise levels because of Tyco Electronics solderless crimping techniques
- Captive inner contact stability
- No danger of heat damage to coaxial cable
- Ease of inspection
- Listed under the Component Program of Underwriters Laboratories Inc., File No. E81956 
- PC Board soldered connectors are recognized under the Component Program of Underwriters Laboratories Inc., File No. E81956 
- Certified by Canadian Standards Association File No. LR 7189 

The Twin BNC Connector is a quick connect/disconnect, weatherproof connector designed in accordance with MIL-C-39012 to meet the stringent requirements of MIL-STD-1553 Multiplex Data Bus.

These twin coaxial cable connectors are a unique development by Tyco Electronics which has resulted in the production of high level RF components. Termination of these connectors to twin conductor cable is made with Tyco Electronics exclusive one crimp method which simultaneously terminates inner conductors, outer braid and cable support with one stroke of the matching Tyco Electronics tool.

These rugged connectors accommodate today's most commonly used twin conductor cable sizes.

### Materials

- Brass** — QQ-B-626
- Beryllium Copper** — QQ-C-530
- PTFE** — MIL-P-19468
- Polypropylene** — General purpose
- Copper, Annealed** — QQ-C-576
- Phosphor Bronze** — QQ-B-750
- Silicone Rubber** — ZZ-R-765

### Plating

- Silver** — QQ-S-365
- Nickel** — QQ-N-290
- Tin** — ASTM-B-545



### Electrical Characteristics

- Nominal Impedance** — Non-constant
- Working Voltage** — 500 volts rms sea level
- Insulation Resistance** — 5000 megohms min.
- Dielectric Withstanding Voltage** — 1500 volts rms sea level

### Mechanical Characteristics

- Mating/Unmating** — Bayonet lock-quick connect/ disconnect
- Cable Attachment** — Crimp type - Simultaneous center and braid
- Coupling Nut Retention** — 100 lbs. [444 N] min.
- Cable Retention** — 25 lbs. [111 N] min., RG 108A/U cable
- Durability** — 200 cycles per MIL-C-39012

### Environmental Characteristics

- Temperature Range** — -55°C to +85°C
- Vibration** — MIL-STD-202, Method 204, Condition B
- Shock** — MIL-STD-202, Method 213, Condition I, 100 G's
- Salt Spray** — MIL-STD-202, Method 101, Condition B
- Temperature Cycling** — MIL-STD-202, Method 102, Condition C

**Packaging** — All connectors are packaged individually unless otherwise noted.



**Twin BNC Connectors (Continued)**

**Plugs**

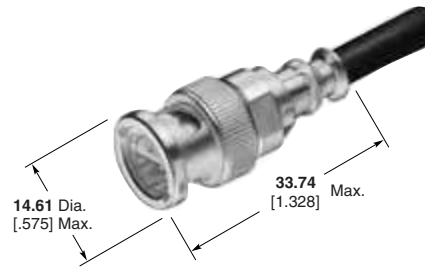

RG/U Cable	Center Contact Plating	Body Plating	Dielectric	Integral Die Hand Tool	Part No.
108, 108A	Silver	Silver	PTFE	69667	<b>5332225</b>
BELDEN 9272, 89272	Silver	Nickel	Polypropylene	69667	<b>5332225-5</b>
TROMPETER TWC-124-2	Silver	Silver	PTFE	69667	<b>5332225-3</b>
ROLM 49D2401 RAYCHEM 7824D013	Silver	Nickel	Polypropylene	69667	<b>5332225-6</b>

**Bulkhead Jack**

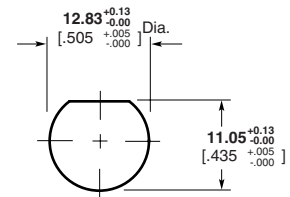
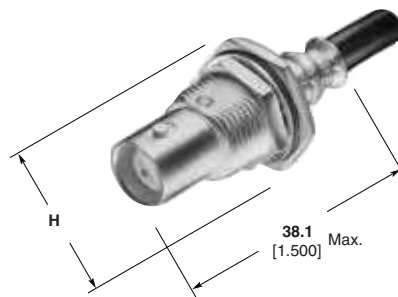

Maximum Panel Thickness 3.18 [ .125 ]

**Recommended Panel Cutout**

H = 17.45 [.687] Max. across flats, 20.32 [.800] Max. across points

RG/U Cable	Center Contact Plating	Body Plating	Dielectric	CERTI-CRIMP Hand Tool with Integral Die	Integral Die Hand Tool	Die Insert for Tools: Hand Tool-69710-1, 626 Pneu. Head 318161-1	Part No.
108, 108A BELDEN 9272, 89272	Silver	Silver	PTFE	—	69667	69708	<b>5332342</b>

BELDEN is a trademark of Belden Wire and Cable Company.  
ROLM is a trademark of the Rolm Corp.  
TROMPETER is a trademark of Trompeter Electronics, Inc.

**Note:** Part Numbers are RoHS compliant except: ♦ Indicates non-RoHS compliant.

**Twin BNC Connectors (Continued)**

**Right-Angle  
PC Board/  
Panel Mount Jacks**

**Material**

**Body** — VALOX, White  
**Center Contacts** — Gold  
**Dielectric** — Polymethylpentene

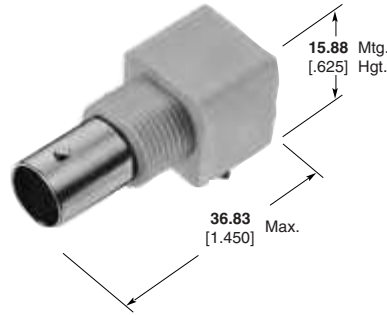

**With Mounting Posts  
Part No. 5228686-1**

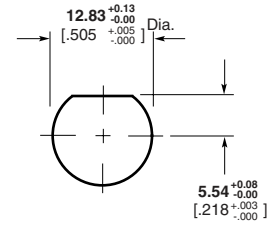

Maximum Panel Thickness 6.1 [0.240]

**Recommended Panel Cutout**

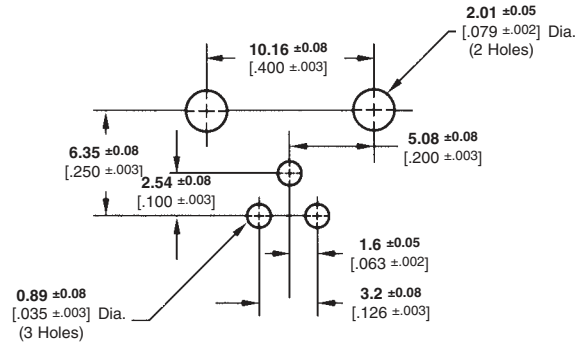

**Recommended PC Board Layout**

**Vertical  
PC Board/  
Panel Mount Jacks**

**Material**

**Body** — VALOX, White  
**Center Contacts** — Gold  
**Dielectric** — Polymethylpentene



**With Mounting Posts  
Part No. 5221198-1**

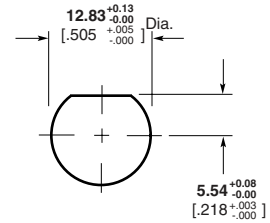

Maximum Panel Thickness 6.1 [0.240]

**Recommended Panel Cutout**

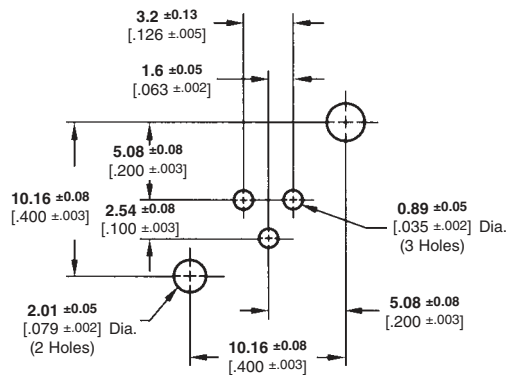

**Recommended PC Board Layout**

**Lockwasher and Jam Nut**



**Part No.  
1-329632-2**



**Part No.  
1-329631-2**

VALOX is a trademark of General Electric Company.

**Note:** Part Numbers are RoHS compliant except: ♦ Indicates non-RoHS compliant.

**Twin BNC Connectors (Continued)**

**Vertical  
PC Board Mount  
Jack**

**Plating**

**Body** — Nickel

**Center Contacts** — Gold

**Dielectric** — Polymethylpentene

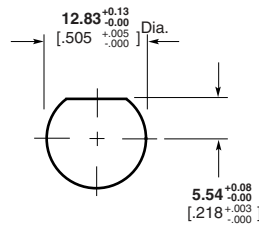

**Part No. 5415832-1**  
**Recommended Panel Cutout**

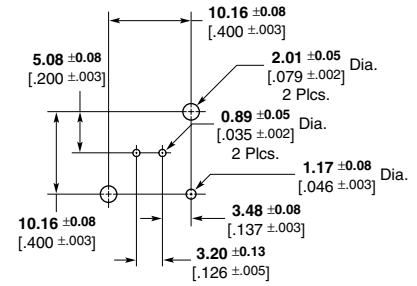

**PCB Configuration**

**Bulkhead Jack  
Adapter**

**Plating**

**Body** — Silver

**Center Contacts** — Silver

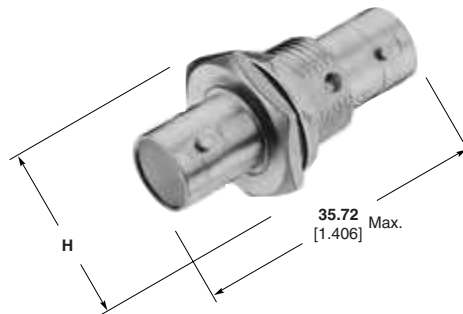

H = 17.45 [0.687] Max. across flats, 20.32 [0.800] Max. across points

**Part No. 5332215**

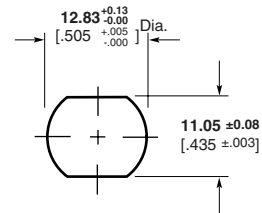

Maximum Panel Thickness 3.18 [0.125]

**Recommended Panel Cutout**

**Note:** Part Numbers are RoHS compliant except: ♦ Indicates non-RoHS compliant.

## F Series and G Series Connectors

### Product Facts

- Designs meet SCTE requirements where applicable
- Plugs, jacks and adapters available
- Board mount and cable mount available
- Surface mount connectors available
- Sealed product available
- High current carrying capabilities



Tyco Electronics F Series connectors offer performance, which is driven by evolving OEM requirements and expectations. Improved VSWR beyond 1 GHz, high current carrying capability, and pressure sealed products are now part of the standard product offering. Designs compliant with ANSI/SCTE, Bellcore, UL/CSA, and various other

industry and agency standards are also available.

Both cable applied and PCB terminated products are offered in a variety of styles. The cable connectors are designed for fast, accurate termination with tools common to the industry. Application cost reductions can be achieved using Tyco Electronics PCB terminated products; press-fit designs eliminate the

need for soldering. Center of gravity control and PCB retention designs prevent tipping and eliminate fixturing during soldering. Integral mechanical keys and "D flats" prevent rotation in panels.

These products provide the highly reliable, cost-effective solutions demanded by today's evolving marketplace.

### Product Specification

- 108-1518 — Connector Coaxial, F Series, RF, Single Crimp Plug
- 108-1643 — Connector Coaxial, F Series, RF, PCB Mounted
- 108-1755 — Connector Economy, F Series, RF Coaxial, PCB
- 108-1757 — Connector, 15 amp, G Series Jack, PCB
- 108-1758 — Connector, F Series Jack, PCB, Surface Mount
- 108-1629 — Feedthrough, Sealed F Port Jack

### Instruction Sheets

- 408-9221 — Coaxial Series F Plug Connectors
- 408-4402 — Series F & G Coaxial Cable Bulkhead Jack Connector
- 408-4291 — PRO-CRIMPER II Hand Tool Assembly 58622-1 and 58622-2

**F Series Connectors**

**Plugs**



RG/U Cable	Termination Type	Body Plating	Style	"B" Threads	PRO-CRIMPER† Hand Tool Assembly	Part No.
6	Crimp	Nickel	A	—	58425-3, 58436-2, or 58621-2	221539-2
6	Screw-On	Nickel	B	M7x1	—	221540-2
59 BELDEN 9104, 9100*	Crimp	Nickel	C	—	58425-3, 58436-2, or 58621-2	414766-1
59	Crimp	Nickel	C	—	58425-3, 58436-2, or 58621-2	414766-8

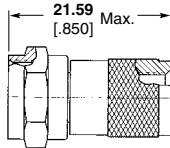

\*NID to inside cable.  
† 8.23 [.324] Hex Crimp.



RG/U Cable	Termination Type	Center Contact Plating	Body Plating	Termination Tooling	Part No.
179 Headend Patch Panel	Crimp	Tin	Nickel	Braid: M 22520/5-01 w/ DANIELS Die Set Hx4-1637 (.128 Hex) Contact: M 22520/2-01 w/ DANIELS Positioner K727, Pos. 2	5415226-1

**Right-Angle Plugs, Crimp**

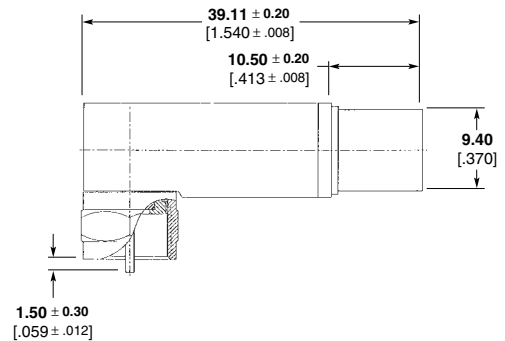

RG/U Cable	Termination Type	Center Contact Plating	Body Plating	Termination Tooling	Part No.
6 Std. Cable	Crimp	Tin	Nickel	use .324 inch Hex	887098-1

BELDEN is a trademark of Belden Wire and Cable Company.  
DANIELS is a trademark of Daniels Manufacturing Corporation.

**Note:** Part Numbers are RoHS compliant except: ♦ Indicates non-RoHS compliant.

**F Series Connectors (Continued)**

**Bulkhead Jacks, Crimp, Rear Mount**



RG/U Cable	Center Contact Plating	Body Plating	Die Set	Part No.
179	Bright Tin	Nickel	220210-1*	5415712-1

\*Use with hand tool 354940-1

**Bulkhead Jacks, Crimp, Splash Resistant, Front Mount**



RG/U Cable	Center Contact Plating	Body Plating	Die Set	Part No.
179	Bright Tin	Nickel	220210-1*	5415569-2

\*Use with hand tool 354940-1

**Right-Angle PC Board Mount Jacks**

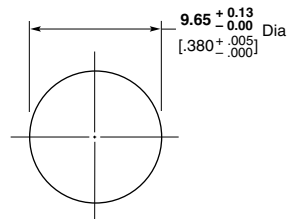
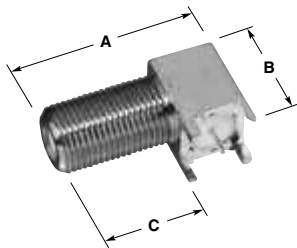

Recommended Panel Cutout

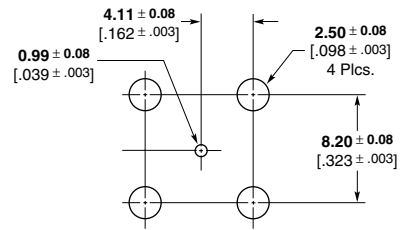

PC Board Layout

Body Plating		Center Contact Plating	Dimensions			Part No.
Barrel	Base		A	B	C	
Nickel	Tin	Tin	25.40 1.00	14.48 .570	15.90 .626	5415302-1
Nickel	Tin	Tin	31.75 1.250	14.48 .570	22.25 .876	5415302-2

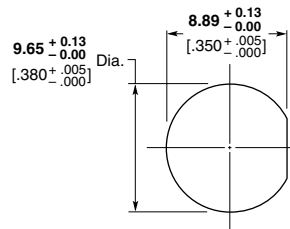
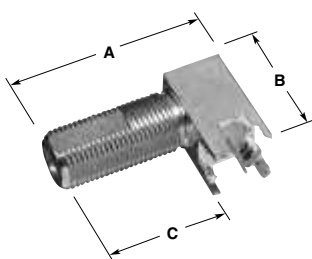

Recommended Panel Cutout

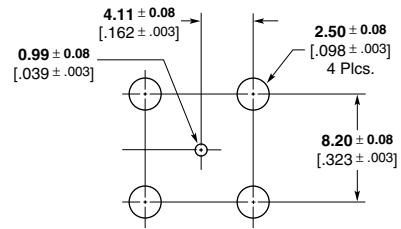

PC Board Layout

Body Plating		Center Contact Plating	Dimensions			Part No.
Barrel	Base		A	B	C	
Nickel	Tin	Tin	29.97 1.180	17.53 .690	12.19 .480	5887078-1

\*Connectors will accept a center conductor, diameter of **0.51-1.19** [0.020-.047]

**Note:** Part Numbers are RoHS compliant except: ♦ Indicates non-RoHS compliant.

**F Series Connectors (Continued)**

**Right-Angle PC Board Mount Jacks (Continued)**

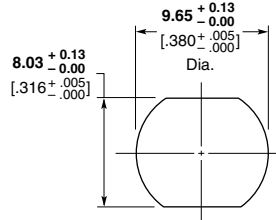
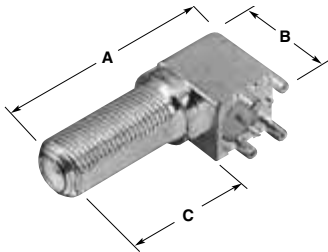

Recommended Panel Cutout

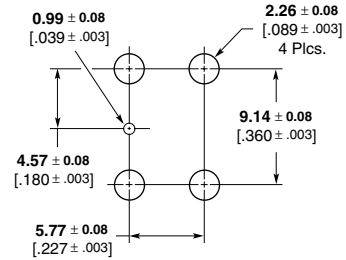

PC Board Layout

Body Plating		Center Contact Plating	Dimensions			Part No.
Barrel	Base		A	B	C	
Nickel	Tin	Tin	33.81 1.331	15.75 .620	19.86 .782	5415276-2*

\*Connector will accept center conductor diameter range of 0.56-1.19 [0.22-.047].

**Right-Angle PC Board Mount Jack, High Temperature**

\*High temperature versions use PTFE dielectric (see table)

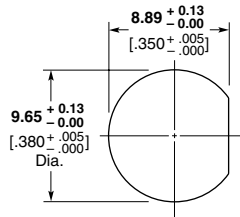
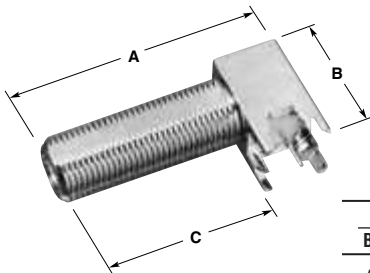

Recommended Panel Cutout

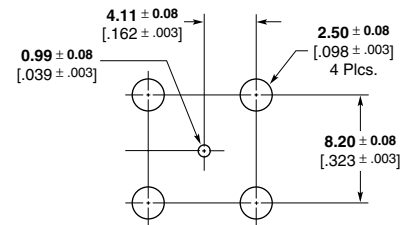

PC Board Layout

Bottom	Dielectric		Solder Post Plating	Dimensions			Part No.
	Middle	Front		A	B	C	
Acetal	Acetal	Polypropylene	Nickel	35.61 1.402	16.89 .665	26.11 1.028	5415024-1
Acetal	Acetal	Polypropylene	Tin	35.61 1.402	16.89 .665	26.11 1.028	5415024-3
PTFE	PTFE	PTFE	Tin	25.40 1.00	17.91 .705	14.99 .590	5415214-1*

\*Pin in paste reflow / high temperature processing.

**Note:** Part Numbers are RoHS compliant except: ♦ Indicates non-RoHS compliant.



**F Series Connectors** (Continued)

**Surface Mount, Straddle Jack**

Contact will accept center conductor diameter range **0.56–1.19** [.022–.047]  
Center of gravity balanced for automated pick and place and anti-tipping during solder reflow process.



Part No. 5415322-2

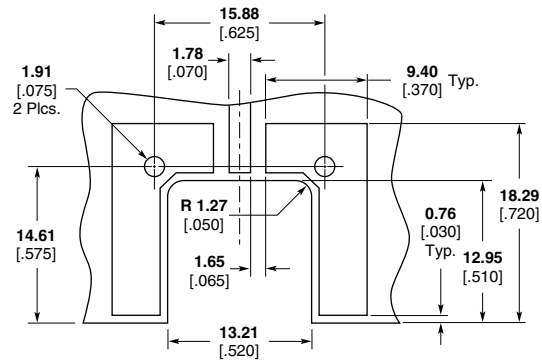

Recommended PC Board Layout

**Vertical PC Board Mount Jacks**

Connector will accept a center conductor diameter of **0.56–1.19** [.022–.047]

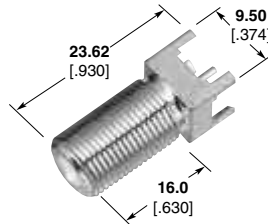

Part No. 5887046-1

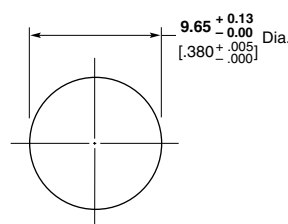

Recommended Panel Cutout

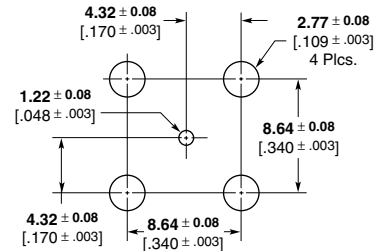

PC Board Layout

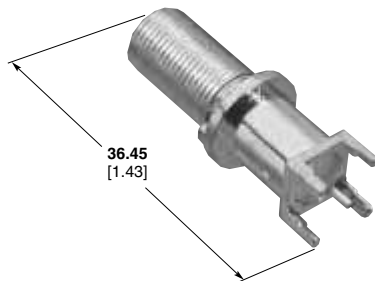

Part No. 6274020-1

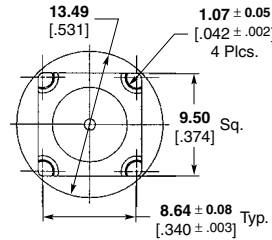

Recommended Panel Cutout

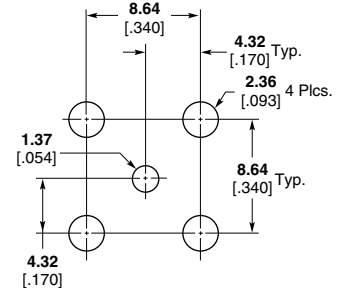

PC Board Layout

**Adapters**

**Jack to Jack Feed through Adapter**



Part No. 282938-2

**Jack to Plug Right-Angle Adapter**



Part No. 5887089-1

**Note:** Part Numbers are RoHS compliant except: ♦ Indicates non-RoHS compliant.

**G Series Connectors**

**Bulkhead Jack, Crimp**



RG/U Cable	Termination Type	Body Plating	Part No.
179	Crimp	Nickel	<b>5415683-1</b>

Termination Tooling: Use 220210-1 die set for Contact only.  
Use Certi-Crimp Hand Tool 220009-1 for ferrule.

**Bulkhead Jack, PC Board**

Connector will accept center conductor diameter range **0.97–1.65** [.038–.065] (415332-1 only)



Part No. 5415332-1 (15 Amp)  
Part No. 6274032-1

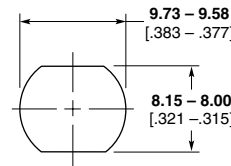

Recommended Panel Cutout for 5415332-1

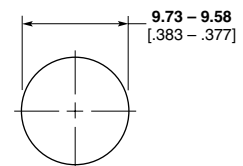

Recommended Panel Cutout for 6274032-1

**Jack, Bulkhead PC Board**

Connector will accept center conductor diameter range **0.97–1.07** [.038–.042]



Part No. 5887000-1

**Right-Angle PC Board Mount Plug**

Includes board retention feature to prevent tipping during solder process.



Part No. 5415406-2

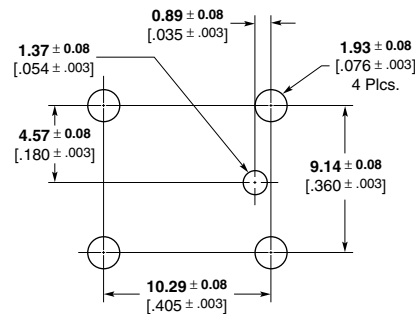

PC Board Layout

**Vertical PC Board Mount Plug**



Part No. 6274045-1

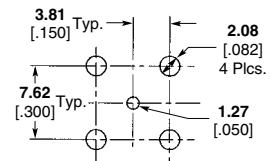
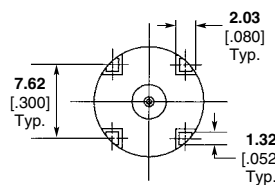

PC Board Layout

**Note:** Part Numbers are RoHS compliant except: ♦ Indicates non-RoHS compliant.

**G Series Connectors** (Continued)

**Adapters**

**F Jack to G Jack  
Bulkhead Adapter**



Part No. 415327-1

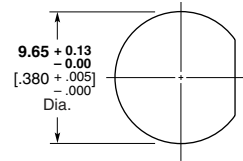

Recommended Panel Cutout

**F Jack to G Plug  
Bulkhead Adapter**

Connector will accept center conductor diameter range of **0.51–1.19** [.020–.047].

Panel nut 887003-3 available for float mounting.



Part No. 415523-1

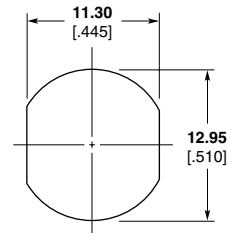

Recommended Panel Cutout

**Note:** Part Numbers are RoHS compliant except: ♦ Indicates non-RoHS compliant.

## SMA Connectors

### Product Facts

- Performance to 12.4 GHz and beyond
- Available in various base metal options, including stainless steel, brass and zinc diecast
- Uses industry standard crimp tools and processes
- Available with corrosion resistant, non-magnetic White Bronze plating
- Meets all performance requirements for MIL-C-39012.



Tyco Electronics offers a complete line of SMA connectors designed for performance to 18 GHz to satisfy the growing demand for SMA connectors in the wireless communications industry. The SMA product line offers stainless steel bodies, as well as non-ferrous metals. Various plating options are available, including Gold and White Bronze. The SMA interface is fully compatible with Mil-C-39012.

While still offering various options on military (QPL) approved connectors, Tyco Electronics has developed a complete offering tailored to the commercial Communications industry. This includes 3 piece flexible cable products for popular RG 316, 142 and RD

316 cable utilizing industry standard HEX crimps.

The SMA series meets the performance, quality and application requirements of the commercial marketplace. This includes White Bronze plating, a unique finish developed by Tyco Electronics to address the performance needs of the telecommunications market. This plating is highly resistant to wear, and contains no ferrous metals, thus displaying excellent inter-modulation characteristics.

To satisfy the broad range of commercial applications, SMA connectors are available in a broad range of standard configurations including; straight and right-angle cable applied plugs, bulkhead cable jacks, two and four hole

flange mount panel jacks, straight and right-angle pcb mount jacks and various between and in series adapters. Numerous packaging and testing options are also available to meet specific system criteria as well.

Additionally, standard military approved (QPL) interfaces are offered as well. Including connectors for semi-rigid cable and micro strip applications.

The 3 Piece SMA offering is designed especially for applications in cellular infrastructure where InterModulation Products (IMP) must be minimized. By limiting non-linearities within the connectors, IMP is reduced and increased channel capacity can be offered.

### Between Series Adapters

For SMA Between Series Adapters, see pages 251-260.

## SMA Connectors (Continued)

### Specifications

MIL-C-39012 Applicable Paragraph		
<b>General</b>		
Material	3.3	Steel corrosion resistant per ASTM-A-582 and ASTM-A-484, Type 303. Beryllium copper per ASTM-B-196. PTFE Fluorocarbon per ASTM-D-1710.
Finish	3.3.1	Center contacts shall be gold plated to a min. thickness of .00127 [.00005] in accordance with MIL-G-45204, ASTM-B-488. All other metal parts shall be finished as to provide a connector which meets the corrosion requirements.
Design	3.4	The design shall be such that the outline shown in this catalog and the interface dimensions of MIL-STD-348A are met.
<b>Electrical</b>		
Insulation Resistance	3.11	The insulation resistance shall not be less than 10,000 megohms.
Corona Level	3.22	Refer to applicable military slash sheet, product drawing or spec.
Dielectric Withstanding Voltage	3.17	Refer to applicable military slash sheet, product drawing or spec.
RF High Potential	3.23	Refer to applicable military slash sheet, product drawing or spec.
Contact Resistance	3.16	Refer to applicable military slash sheet, product drawing or spec.
VSWR	3.14	Refer to applicable military slash sheet, product drawing or spec. Frequency range dependent on cable used.
RF Leakage	3.26	Refer to applicable military slash sheet, product drawing or spec.
Insertion Loss	3.27	Refer to applicable military slash sheet, product drawing or spec. Frequency range dependent on cable used.
<b>Mechanical</b>		
Force to Engage	3.5.1	The torque required to engage and disengage shall not exceed 2 in.-lbs. The longitudinal force is not applicable.
Coupling Nut Retention	3.25	60 lbs. min. Applicable for plug connectors only.
Coupling Proof Torque	3.6	15 in.-lbs. min. Applicable for plug connectors only.
Cable Retention	3.24	Refer to applicable military slash sheet or consult factory.
Mating Characteristics	3.7	Applicable to jack connectors only. Reference MIL-STD-348A for dimensions; oversize test pin .953 [.0375] min. dia., .76 - 1.14 [.030-.045] deep, insertion force 3 lbs. max. with .940 [.0370] min. dia. pin, withdrawal force 1 oz. min. with .902 [.0355] max. dia. pin.
Connector Durability	3.15	The connector to be tested and its mating connector shall be subjected to 500 insertion and withdrawal cycles at 12 cycles per minute max. The connector shall show no evidence of mechanical failure and shall meet the mating characteristic requirements.
Recommended Mating Torque	—	7 to 10 in.-lbs.
<b>Environmental</b>		
Vibration	3.18	Specification MIL-STD-202, method 204, test condition D
Shock	3.19	Specification MIL-STD-202, method 213, test condition I
Thermal Shock	3.20	Refer to applicable military slash sheet or consult factory.
Corrosion (Salt Spray)	3.13	Specification MIL-STD-202, method 101, test condition B.
Moisture Resistance	3.21	Specification MIL-STD-202, method 106. No measurements at high humidity. Insulation resistance shall be at least 200 megohms within 5 minutes of removal from humidity.

**SMA Connectors (Continued)**
**Electrical**

Connector Type	Cable	Frequency Max. (GHz)	VSWR x (fGHz)	Contact Resistance (milliohms max.)		Insulation Resistance (megohms min.)	Dielectric Withstanding Voltage (Volts RMS)	Corona Extinction Voltage at 70,000 Ft. (V RMS min.)	RF Transmission Loss	RF High Potential at 5 MHz (V RMS)	RF Leakage (dB min.)
				Center Contact	Outer Contact						
Straight Cable Plug without Contact	RG 402 (3.58 [.141])	Note 1	1.02 + .005	N/A	2.0	10,000	N/A	250	N/A	670	-(90-fGHz)
	RG 405 (2.16 [.085])	18.0	1.05 + .005	2.0	2.0	10,000	1000	250	.03 $\sqrt{f}$ (GHz)	670	-(90-fGHz)
Straight Cable Plugs & Jacks Solder Attachment	RG 402 (3.58 [.141])	18.0	1.05 + .005	2.0	2.0	10,000	1500	375	.03 $\sqrt{f}$ (GHz)	1000	-(90-fGHz)
	3.58 [.141] Microporous	18.0	1.05 + .005	2.0	2.0	10,000	1500	375	.03 $\sqrt{f}$ (GHz)	1000	-(90-fGHz)
	RG 401 (6.35 [.250])	18.0	1.07 + .007	2.0	2.0	10,000	1500	375	.03 $\sqrt{f}$ (GHz)	1000	-(90-fGHz)
	RG 174, 188, 316	Note 1	1.15 + .01	2.0	2.0	10,000	750	190	.06 $\sqrt{f}$ (GHz)	500	-(60-fGHz)
Straight Cable Plugs & Jacks Solder Clamp Attachment	RG 55, 58, 141, 142, 223, 303, 400	Note 1	1.10 + .005	2.0	2.0	10,000	1000	250	.06 $\sqrt{f}$ (GHz)	670	-(60-fGHz)
	RG 405 (2.16 [.085])	12.4	1.10 + .015	2.0	2.0	10,000	1000	250	.03 $\sqrt{f}$ (GHz)	670	-(90-fGHz)
Straight Cable Plugs & Jacks Solder Clamp Attachment	RG 402 (3.58 [.141])	12.4	1.07 + .01	2.0	2.0	10,000	1500	375	.03 $\sqrt{f}$ (GHz)	1000	-(90-fGHz)
	RG 55, 58, 141, 142, 223, 400	Note 1	1.10 + .005	2.0	2.0	10,000	1000	250	.06 $\sqrt{f}$ (GHz)	670	-(60-fGHz)
Straight Cable Plugs & Jacks Clamp Attachment	RG 174, 188, 316	Note 1	1.15 + .01	2.0	2.0	10,000	750	190	.06 $\sqrt{f}$ (GHz)	500	-(60-fGHz)
	RG 180, 195	Note 1	—	2.0	2.0	10,000	750	190	—	500	-(60-fGHz)
	RG 55, 142, 223, 400	Note 1	1.10 + .005	2.0	2.0	10,000	1000	250	.06 $\sqrt{f}$ (GHz)	670	-(60-fGHz)
Straight Cable Plugs & Jacks Crimp Attachment	RG 58, 141, 303	Note 1	1.10 + .005	2.0	2.0	10,000	1000	250	.06 $\sqrt{f}$ (GHz)	670	-(60-fGHz)
	RG 174, 188, 316	Note 1	1.15 + .01	2.0	2.0	10,000	750	190	.06 $\sqrt{f}$ (GHz)	500	-(60-fGHz)
	RG 180, 195	Note 1	—	2.0	2.0	10,000	750	190	—	500	-(60-fGHz)
	RG 178, 196	Note 1	1.2 + .02	2.0	2.0	10,000	500	125	.06 $\sqrt{f}$ (GHz)	335	-(60-fGHz)
Straight Cable Plugs & Jacks Compression Clamp Attachment	RG 401 (6.35 [.250])	18.0	1.07 + .01	2.0	2.0	10,000	1500	375	.05 $\sqrt{f}$ (GHz)	1000	-70 dB min.
	6.35 [.250] Microporous	18.0	1.07 + .01	2.0	2.0	10,000	1500	375	.05 $\sqrt{f}$ (GHz)	1000	-70 dB min.
	6.35 [.250] 3 Spline	18.0	1.07 + .01	2.0	2.0	10,000	1500	375	.05 $\sqrt{f}$ (GHz)	1000	-70 dB min.
	6.35 [.250] 5 Spline	18.0	1.07 + .01	2.0	2.0	10,000	1500	375	.05 $\sqrt{f}$ (GHz)	1000	-70 dB min.
Right-Angle Cable Plugs Solder Attachment	RG 405 (2.16 [.085])	12.4	1.18 + .015	2.0	2.0	10,000	1000	250	.04 $\sqrt{f}$ (GHz)	670	-(90-fGHz)
	RG 405 (2.16 [.085])	18.0	1.18 + .015	2.0	2.0	10,000	1000	250	.04 $\sqrt{f}$ (GHz)	670	-(90-fGHz)
	RG 402 (3.58 [.141])	12.4	1.15 + .015	2.0	2.0	10,000	1500	325	.04 $\sqrt{f}$ (GHz)	1000	-(90-fGHz)
	RG 402 (3.58 [.141])	18.0	1.10 + .010	2.0	2.0	10,000	1500	250	.05 $\sqrt{f}$ (GHz)	1000	-(90-fGHz)
	RG 55, 58, 141, 142, 223, 303, 400	Note 1	1.15 + .01	2.0	2.0	10,000	1000	250	.07 $\sqrt{f}$ (GHz)	670	-(60-fGHz)
	RG 174, 188, 316	Note 1	1.15 + .02	2.0	2.0	10,000	750	190	.07 $\sqrt{f}$ (GHz)	500	-(60-fGHz)
Right-Angle Cable Plugs Crimp Attachment	RG 55, 142, 223, 400	Note 1	1.15 + .02	2.0	2.0	10,000	1000	250	.07 $\sqrt{f}$ (GHz)	670	-(60-fGHz)
	RG 58, 141, 303	Note 1	1.15 + .02	2.0	2.0	10,000	1000	250	.07 $\sqrt{f}$ (GHz)	670	-(60-fGHz)
	RG 174, 188, 316	Note 1	1.18 + .02	2.0	2.0	10,000	750	190	.07 $\sqrt{f}$ (GHz)	500	-(60-fGHz)
	RG 180, 195	Note 1	—	2.0	2.0	10,000	750	190	—	500	-(60-fGHz)
Right-Angle Cable Plugs Clamp Attachment	RG 178, 196	Note 1	1.25 + .025	2.0	2.0	10,000	500	125	.07 $\sqrt{f}$ (GHz)	335	-(60-fGHz)
	RG 55, 58, 141, 142, 223, 303	Note 1	1.10 + .005	2.0	2.0	10,000	1000	250	.08 $\sqrt{f}$ (GHz)	670	-(60-fGHz)
	RG 174, 188, 316	Note 1	1.15 + .01	2.0	2.0	10,000	750	190	.08 $\sqrt{f}$ (GHz)	500	-(60-fGHz)
Flange Mount Plugs & Jacks Panel or Bulkhead Mount	RG 180, 195	Note 1	—	2.0	2.0	10,000	750	190	—	500	-(60-fGHz)
	Non-Captured	18.0	1.03 + .004	2.0	2.0	10,000	1000	250	.03 $\sqrt{f}$ (GHz)	670	-(100-fGHz)
	Epoxy Captured	18.0	1.05 + .005	2.0	2.0	10,000	1000	250	.03 $\sqrt{f}$ (GHz)	670	-(60-fGHz)
	Mechanical Capture	18.0	1.04 + .004	2.0	2.0	10,000	1000	250	.03 $\sqrt{f}$ (GHz)	670	-(100-fGHz)
Bulkhead Feedthrough Jacks	Field Replaceable Hermetic Launchers	18.0	1.04 + .006	2.0	2.0	10,000	1000	250	.04 $\sqrt{f}$ (GHz)	670	-(100-fGHz)
	Epoxy Captured	18.0	1.07 + .010	2.0	2.0	10,000	1000	250	.04 $\sqrt{f}$ (GHz)	670	-(60-fGHz)
Right-Angle Flange Mount Jacks	Mechanical Capture	18.0	1.07 + .010	2.0	2.0	10,000	1000	250	.04 $\sqrt{f}$ (GHz)	670	-(100-fGHz)
	N/A	18.0	1.07 + .015	2.0	2.0	10,000	1000	250	.08 $\sqrt{f}$ (GHz)	670	-(90-fGHz)
Printed Circuit Board Mount Straight Terminal	N/A	12.4	1.15 + .015	2.0	2.0	10,000	1000	250	.08 $\sqrt{f}$ (GHz)	670	-(90-fGHz)
	N/A	18.0	N/A	2.0	2.0	10,000	1000	250	N/A	670	N/A
Right-Angle Printed Circuit	N/A	12.4	N/A	2.0	2.0	10,000	1000	250	N/A	670	N/A
End Launch Stripline Circuit	N/A	18.0	1.05 + .005	2.0	2.0	10,000	1000	250	.03 $\sqrt{f}$ (GHz)	670	-(60-fGHz)
Surface Launch Stripline Circuit	N/A	18.0	1.05 + .005	2.0	2.0	10,000	1000	250	.03 $\sqrt{f}$ (GHz)	670	-(60-fGHz)
Right-Angle Surface Launch Stripline Circuit	N/A	12.4	1.15 + .015	2.0	2.0	10,000	1000	250	.08 $\sqrt{f}$ (GHz)	670	-(60-fGHz)
	N/A	18.0	1.07 + .015	2.0	2.0	10,000	1000	250	.08 $\sqrt{f}$ (GHz)	670	-(60-fGHz)

1. Maximum operating frequency of cable per MIL-C-17.
2. Specifications do not apply to hermetic or compression crimp connectors.
3. For Brass SMA: Frequency Range DC-6GHz, Impedance 50 Ohms, Insulation Resistance.

**SMA Connectors** (Continued)

**Interface Mating Dimensions**

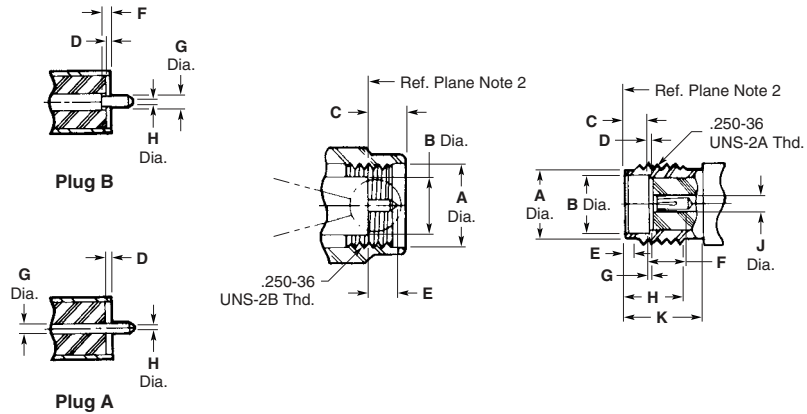

**Plug**

Dimension	Minimum	Maximum
A	<b>6.35</b> .250	—
B	—	<b>4.59</b> .1808
C	—	<b>3.43</b> .135
D	<b>0.00</b> .000	<b>0.25</b> .010
E	—	<b>2.54</b> .100
F	<b>0.00</b> .000	<b>0.25</b> .010
G	<b>0.90</b> .0355	<b>0.94</b> .037
H	<b>0.00</b> .000	<b>0.38</b> .015

**Jack**

Dimension	Minimum	Maximum
A	<b>5.28</b> .208	<b>5.49</b> .216
B	<b>4.60</b> .181	—
C	<b>1.91</b> .075	<b>1.98</b> .078
D	<b>0.00</b> .000	<b>0.25</b> .010
E	<b>0.38</b> .015	<b>1.43</b> .045
F	<b>2.92</b> .115	—
G	<b>0.00</b> .000	<b>0.25</b> .010
H	<b>4.32</b> .170	—
J	<b>1.24</b> .049	<b>1.30</b> .051
K	<b>5.54</b> .218	—

**Notes:**

1. ID to meet VSWR and contact resistance when mated with 0.51 +.025/-.013 [.036 +.0010/-.0005] Dia. Pin.
2. When fully engaged, the two reference planes must coincide with metal to metal contact.
3. Metric equivalents (to the nearest 0.01mm) are given for general information only.



**SMA Connectors (Continued)**  
**Flexible Cable**

**Straight Cable Plug, Solder**

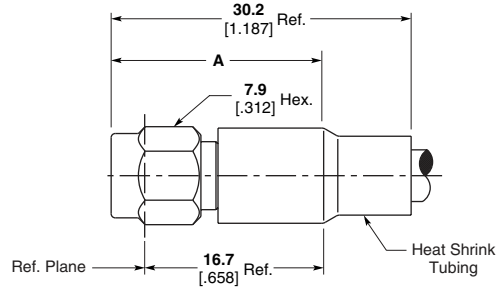

Cable Type RG/U	Body Material & Finish	Contact Captivation	Contact Attachment	Dimension A	Instruction Sheet	Part No.
55, 58, 141, 142, 223, 303, 400	Stainless, Gold <sup>1</sup>	No	Solder	<b>19.7</b> .775	408-4821	<b>1051638-1</b>
174, 188, 316	Stainless, Gold <sup>1</sup>	No	Solder	<b>17.5</b> .690	408-4756	<b>1051644-1</b>

<sup>1</sup>Coupling nut is passivated stainless steel.

**Straight Cable Jack, Solder**

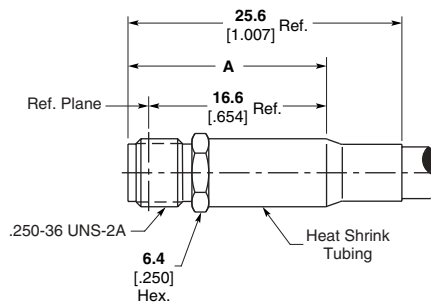

Cable Type RG/U	Body Material & Finish	Contact Captivation	Contact Attachment	Dimension A	Instruction Sheet	Part No.
55, 58, 141, 142, 223, 303, 400	Stainless, Gold	No	Solder	<b>18.5</b> .730	408-4820	<b>1051852-1</b>

**Bulkhead Cable Jack, Solder**

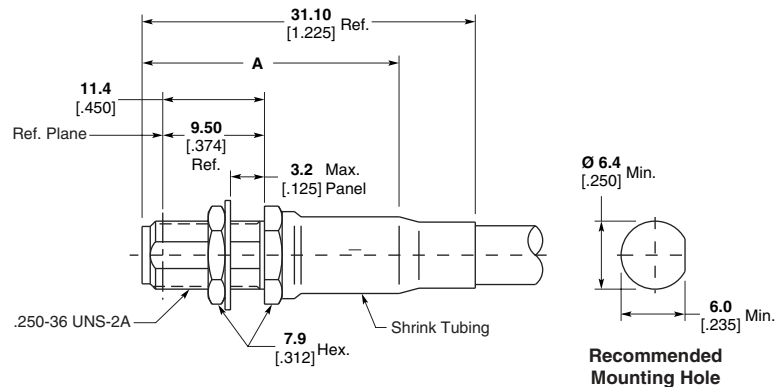

Cable Type RG/U	Body Material & Finish	Contact Captivation	Contact Attachment	Dimension A	Instruction Sheet	Part No.
RG 55, 58, 141, 142, 300	Stainless, Gold	No	Solder	<b>24.0</b> .945	408-4817	<b>1051861-1</b>
174, 188, 316	Stainless, Gold	No	Solder	<b>21.0</b> .825	408-4817	<b>1051942-1</b>

**Note:** Part Numbers are RoHS compliant except: ♦ Indicates non-RoHS compliant.

**SMA Connectors** (Continued)  
**Flexible Cable** (Continued)

**Right-Angle Cable Plug, Solder**

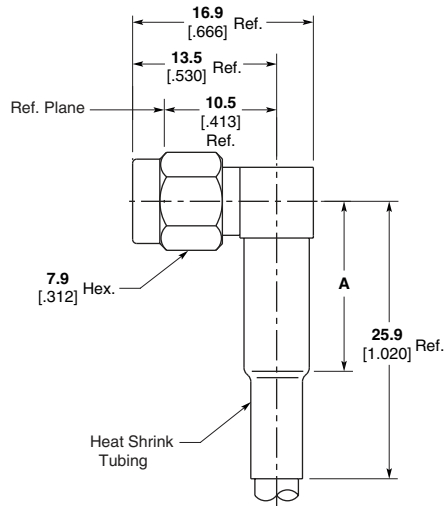

Cable Type RG/U	Body Material & Finish	Contact Captivation	Contact Attachment	Dimension A	Instruction Sheet	Part No.
55, 58, 141, 142, 223, 303, 400	Stainless, Gold <sup>1</sup>	Yes	Solder	16.0 .630	408-4816	1052063-1
174, 188, 316	Stainless, Gold <sup>1</sup>	Yes	Solder	11.2 .440	408-4815	1052067-1

<sup>1</sup>Coupling nut is passivated stainless steel.

**Straight Cable Plug, Clamp**

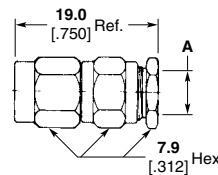

Cable Type RG/U	Body Material & Finish	Contact Captivation	Contact Attachment	Dimension A	Instruction Sheet	Part No.
174, 188, 316	Stainless, Pass.	Yes	Solder	2.9 .116	408-4906	1050721-1

**Straight Cable Jack, Clamp**

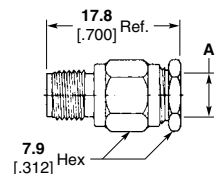

Cable Type RG/U	Body Material & Finish	Contact Captivation	Contact Attachment	Dimension A	Instruction Sheet	Part No.
174, 188, 316	Stainless, Pass.	Yes	Solder	2.9 .116	408-4906	1050903-1

**Note:** Part Numbers are RoHS compliant except: ♦ Indicates non-RoHS compliant.

**SMA Connectors** (Continued)  
**Flexible Cable** (Continued)

**Bulkhead Feedthrough Cable Jack, Clamp**

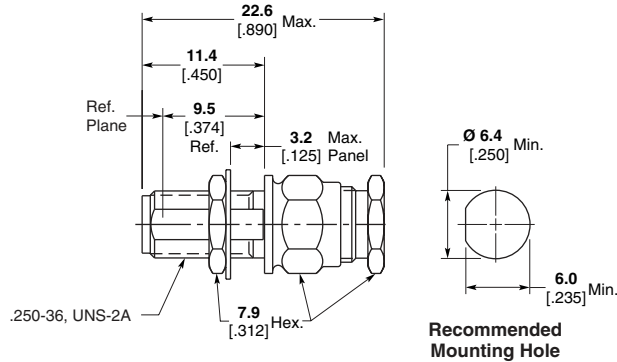

Cable Type RG/U	Body Material & Finish	Contact Captivation	Contact Attachment	Instruction Sheet	Part No.
174, 188, 316	Stainless, Pass.	Yes	Solder	408-4704	1050996-1

**Right-Angle Cable Plug, Clamp**

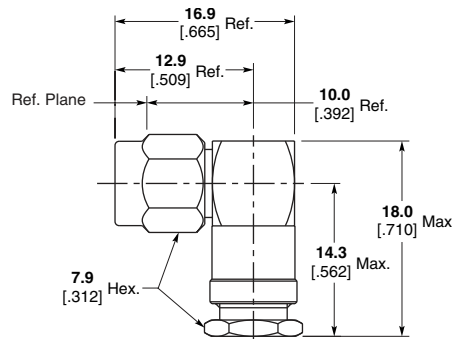

Cable Type RG/U	Body Material & Finish	Contact Captivation	Contact Attachment	Instruction Sheet	Part No.
174, 188, 316	Stainless, Pass.	Mechanical	Solder	408-4965	1051140-1

**Straight Cable Plug, Crimp**

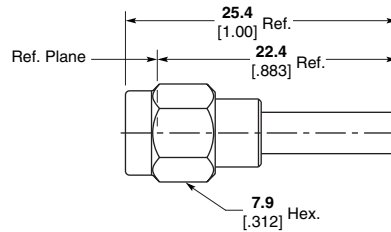

Cable Type RG/U	Body Material & Finish	Contact Captivation	Contact Attachment	Crimp Tooling Part No.	Instruction Sheet	Part No.
174, 179, 187, 188, 316	Stainless, Pass.	Mechanical	Solder/Crimp <sup>2</sup>	1055236-1	408-4661	1056443-1
RD316	Stainless, Pass.	Mechanical	Solder/Crimp <sup>2</sup>	1055236-1 <sup>1</sup>	408-4661	1056436-1
55, 142, 223, 400	Stainless, Pass.	Mechanical	Solder/Crimp <sup>2</sup>	1055236-1	408-4661	1056438-1
174, 179, 187, 188, 316	Brass, White Bronze	Mechanical	Solder/Crimp <sup>2</sup>	1055236-1	408-4661	1082034-1

<sup>1</sup>Use die 1055270-1 to crimp RD316 ferrule.  
<sup>2</sup>Use die 1055880-1 to crimp center contact.

**Note:** Part Numbers are RoHS compliant except: ♦ Indicates non-RoHS compliant.

**SMA Connectors** (Continued)  
**Flexible Cable** (Continued)

**Straight Cable Jack, Crimp**

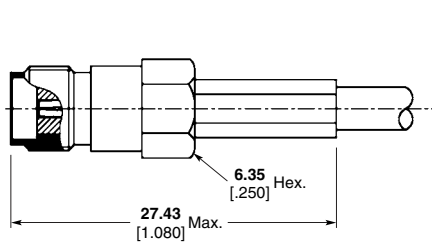

Style A

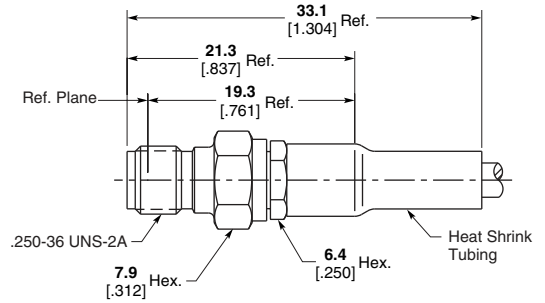

Style B

Cable Type RG/U	Body Material & Finish	Contact Captivation	Contact Attachment	Crimp Tooling Part No.	Instruction Sheet	Style	Part No.
174, 316	Brass, Nickel	Mechanical	Solder	1	408-4032	A	<b>5447648-3</b>
58, 141, 303	Stainless, Pass.	Mechanical	Solder	1055236-1	408-4704	B	<b>1051867-1</b>
174, 188, 316	Stainless, Pass.	Mechanical	Solder	1055236-1	408-4708	B	<b>1051855-1</b>
178, 196	Stainless, Pass.	Mechanical	Solder	1055236-1	408-4806	B	<b>1051869-1</b>

<sup>1</sup>Refer to Tyco Electronics Customer Print for tooling requirement. DANIELS Mil Tooling used for contact and ferrule crimp.

**Bulkhead Feedthrough  
Cable Jack, Crimp**

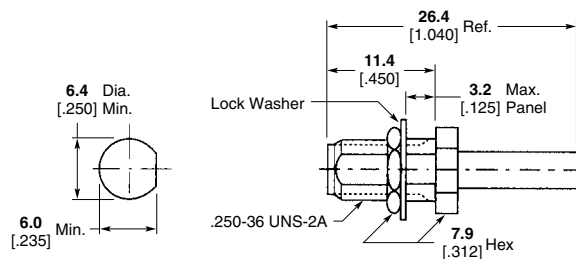

**Recommended  
Mounting Hole**

Cable Type RG/U	Body Material & Finish	Contact Captivation	Contact Attachment	Crimp Tooling Part No.	Instruction Sheet	Part No.
174, 179, 187, 188, 316	Stainless, Pass.	Mechanical	Solder/Crimp <sup>2</sup>	1055236-1	408-4661	<b>1056452-1</b>
RD316	Stainless, Pass.	Mechanical	Solder/Crimp <sup>2</sup>	1055236-1 <sup>3</sup>	408-4661	<b>1056445-1</b>
58, 141, 303	Stainless, Pass.	Mechanical	Solder/Crimp <sup>2</sup>	1055236-1	408-4661	<b>1056450-1</b>
55, 142, 223, 400	Stainless, Pass.	Mechanical	Solder/Crimp <sup>2</sup>	1055236-1	408-4661	<b>1056447-1</b>
174, 188, 316	Brass, Nickel	Mechanical	Crimp	1	408-4032	<b>5448103-2</b>

<sup>1</sup>Refer to Tyco Electronics Customer Print for tooling requirement. DANIELS Mil Tooling used for contact and ferrule crimp.

<sup>2</sup>Use die 1055880-1 to crimp center contact.

<sup>3</sup>Use die 1055270-1 to crimp RD316 ferrule.

DANIELS is a trademark of Daniels Manufacturing Corporation.

**Note:** Part Numbers are RoHS compliant except: ♦ Indicates non-RoHS compliant.

**SMA Connectors** (Continued)  
**Flexible Cable** (Continued)

**Right-Angle Cable Plug, Crimp**

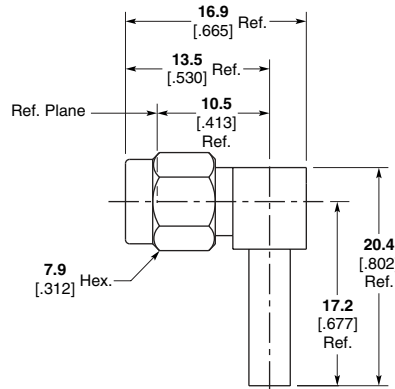

Cable Type RG/U	Body Material & Finish	Contact Captivation	Contact Attachment	Crimp Tooling Part No.	Instruction Sheet	Part No.
174, 179, 187, 188, 316	Stainless, Pass.	Mechanical	Solder	1055236-1	408-4659	<b>1056462-1</b>
58, 141, 303	Stainless, Pass.	Mechanical	Solder	1055236-1	408-4659	<b>1056456-1</b>

**Right-Angle Cable Plug, Crimp**

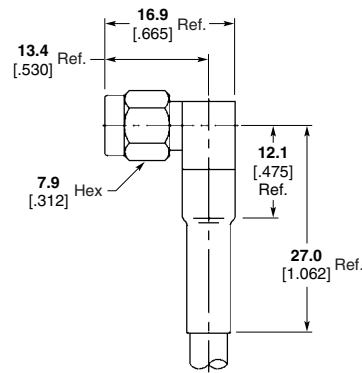

Cable Type RG/U	Body Material & Finish	Contact Captivation	Contact Attachment	Crimp Tooling Part No.	Instruction Sheet	Part No.
55, 142, 223, 400	Stainless, Pass.	Epoxy	Solder	1055236-1	408-4681	<b>1052072-1</b>
174, 188, 316	Stainless, Pass.	Epoxy	Solder	1055236-1	408-4683	<b>1052076-1</b>
178, 196	Stainless, Pass.	Epoxy	Solder	1055236-1	408-4801	<b>1052098-1</b>

**Note:** Part Numbers are RoHS compliant except: ♦ Indicates non-RoHS compliant.

**SMA Connectors** (Continued)  
**Flexible Cable** (Continued)

**Straight Push-On**

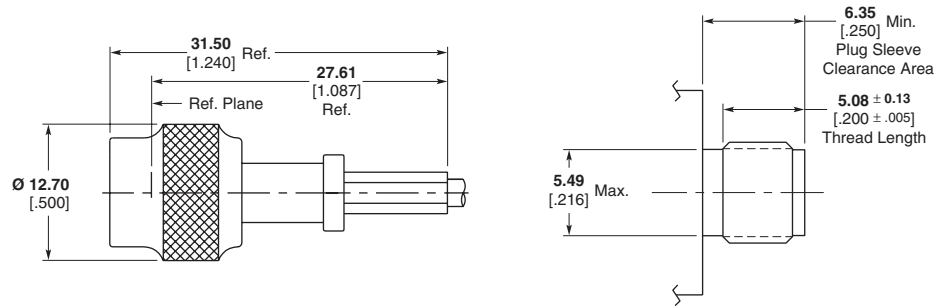

Cable Type RG/U	Body Material & Finish	Contact Captivation	Contact Attachment	Part No.
316	Beryllium Copper, Gold	Mechanical	Crimp	1408541-1

**Right-Angle Push-On**

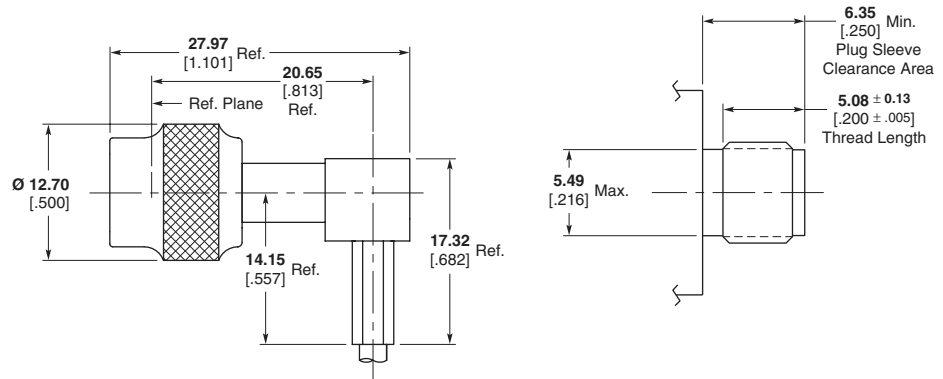

Cable Type RG/U	Body Material & Finish	Contact Captivation	Contact Attachment	Part No.
316	Beryllium Copper, Gold	Mechanical	Solder/Crimp	1274694-1

**Note:** Part Numbers are RoHS compliant except: ♦ Indicates non-RoHS compliant.

**SMA Connectors** (Continued)  
**Direct Solder Attachment, Semi-Rigid Cable**

**Straight Cable Plug**

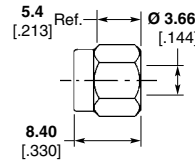

Cable Type RG/U	Body Material & Finish	Contact Captivation	Contact Attachment	Solder Assembly Kit Part No.	Instruction Sheet	Part No.
402 (3.58 [0.141])	Stainless, Pass.	No Center Contact	No Center Contact	1055420-1	408-4761	<b>1050757-1</b>

**Straight Cable Plug**

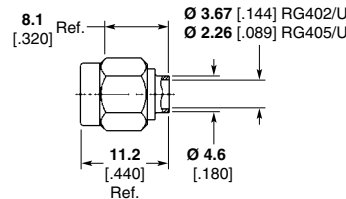

Cable Type RG/U	Body Material & Finish	Contact Captivation	Contact Attachment	Solder Assembly Kit Part No.	Instruction Sheet	Part No.
402 (3.58 [0.141])	Stainless, Gold <sup>1</sup>	No	Solder	1055420-1	408-4764	<b>1050525-1</b>
405 (2.16 [0.085])	Stainless, Gold <sup>1</sup>	No	Solder	1055420-1	408-4765	<b>1050770-1</b>
402 (3.58 [0.141])	Stainless, Gold <sup>1</sup>	No Center Contact	No Center Contact	N/A	—	<b>1050542-1</b>
405 (2.16 [0.085])	Stainless, Gold <sup>1</sup>	No	Solder	1055420-1	—	<b>1050548-1</b>

<sup>1</sup>Coupling nut is passivated stainless steel.

**Straight Cable Jack**

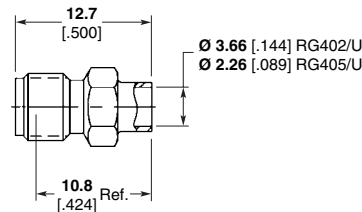

Cable Type RG/U	Body Material & Finish	Contact Captivation	Contact Attachment	Solder Assembly Kit Part No.	Instruction Sheet	Part No.
402 (3.58 [0.141])	Stainless, Gold	No	Solder	1055420-1	408-4767	<b>1050854-1</b>
405 (2.16 [0.085])	Stainless, Gold	No	Solder	1055420-1	408-4833	<b>1050859-1</b>

**Note:** Part Numbers are RoHS compliant except: ♦ Indicates non-RoHS compliant.



**SMA Connectors (Continued)**  
**Direct Solder Attachment, Semi-Rigid Cable (Continued)**

**Bulkhead Cable Jack**

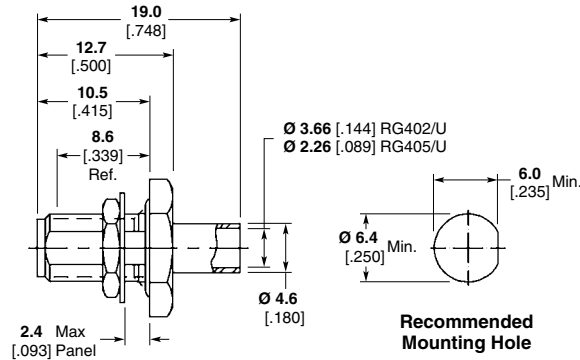

Cable Type RG/U	Body Material & Finish	Contact Captivation	Contact Attachment	Solder Assembly Kit Part No.	Instruction Sheet	Part No.
402 (3.58 [.141])	Brass, Gold	No	Solder	1055420-1	408-4768	<b>1082029-1</b>

**2 Hole Flange Mount  
Cable Jack**

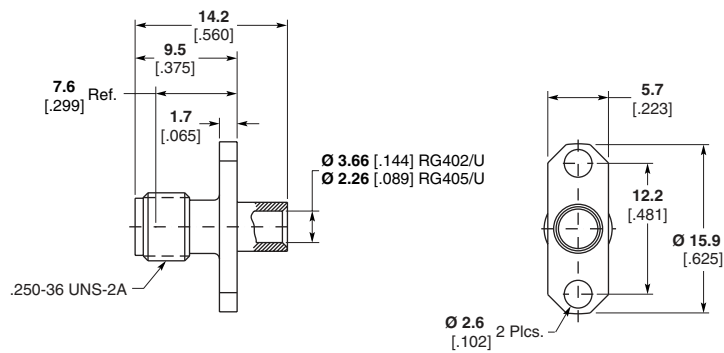

Cable Type RG/U	Body Material & Finish	Contact Captivation	Contact Attachment	Solder Assembly Kit Part No.	Instruction Sheet	Part No.
402 (3.58 [.141])	Stainless, Gold	No	Solder	1055420-1	408-4767	<b>1051052-1</b>
405 (2.16 [.085])	Stainless, Gold	No	Solder	1055420-1	408-4883	<b>1051046-1</b>

**4 Hole Flange Mount  
Cable Jack**

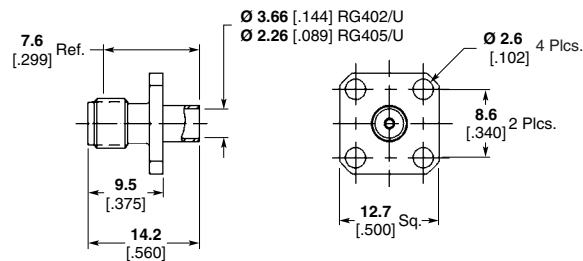

Cable Type RG/U	Body Material & Finish	Contact Captivation	Contact Attachment	Solder Assembly Kit Part No.	Instruction Sheet	Part No.
402 (3.58 [.141])	Stainless, Gold	No	Solder	1055420-1	408-4767	<b>1051081-1</b>
405 (2.16 [.085])	Stainless, Gold	No	Solder	1055420-1	408-4883	<b>1051085-1</b>

**Note:** Part Numbers are RoHS compliant except: ♦ Indicates non-RoHS compliant.

**SMA Connectors** (Continued)  
**Semi-Rigid Cable**

**Right-Angle Cable Plug,  
Direct Solder Attachment**

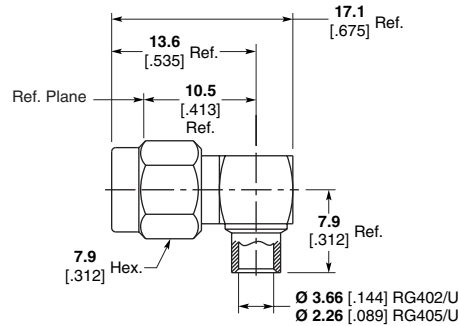

Cable Type RG/U	Body Material & Finish	Contact Captivation	Contact Attachment	Solder Assembly Kit Part No.	Instruction Sheet	Part No.
402 (3.58 [0.141])	Stainless, Gold <sup>1</sup>	Epoxy	Solder	1055420-1	408-4831	<b>1051151-1</b>
405 (2.16 [0.085])	Stainless, Gold <sup>1</sup>	Epoxy	Solder	1055420-1	408-4831	<b>1051157-1</b>
405 (2.16 [0.085])	Brass, Gold	Mechanical	Solder	1055420-1	408-4831	<b>1088312-1</b>

<sup>1</sup>Coupling nut is passivated stainless steel.

**Straight Cable Plug, Crimp**

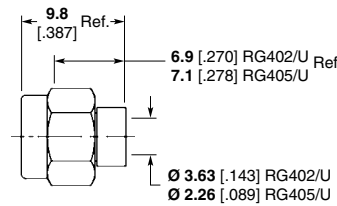

Cable Type RG/U	Body Material & Finish	Contact Captivation	Contact Attachment	Crimp Tooling Part No.	Instruction Sheet	Part No.
405 (2.16 [0.085])	Stainless, Pass.	Mechanical	Solderless	1055835-1	408-4695	<b>1050598-1</b>
402 (3.58 [0.141])	Stainless, Pass.	No Center Contact	Solderless	1055835-1	408-4690	<b>1050740-1</b>

**Straight Cable Plug —  
Low Profile, Crimp**

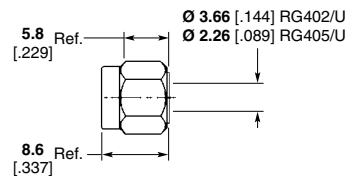

Cable Type RG/U	Body Material & Finish	Contact Captivation	Contact Attachment	Crimp Tooling Part No.	Instruction Sheet	Part No.
402 (3.58 [0.141])	Stainless, Pass.	Mechanical	Solderless	1055835-1	408-4696	<b>1050602-1</b>
405 (2.16 [0.085])	Stainless, Pass.	Mechanical	Solderless	1055835-1	408-4697	<b>1050611-1</b>

**Note:** Part Numbers are RoHS compliant except: ♦ Indicates non-RoHS compliant.

**SMA Connectors** (Continued)  
**Semi-Rigid Cable** (Continued)

**2 Hole Flange, Crimp**

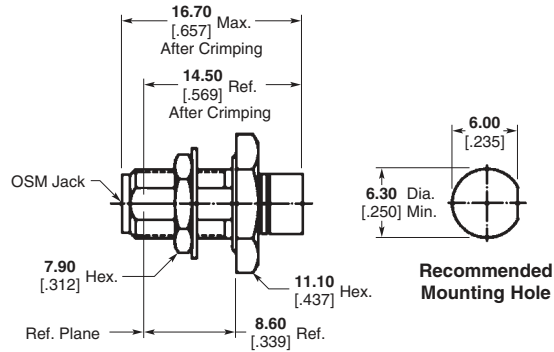

Cable Type RG/U	Body Material & Finish	Contact Captivation	Contact Attachment	Crimp Tooling Part No.	Instruction Sheet	Part No.
402 (3.58 [.141])	Stainless, Pass.	Mechanical	Solderless	1055835-1	408-4954	<b>1051005-1</b>
405 (2.16 [.085])	Stainless, Pass.	Mechanical	Solderless	1055835-1	408-4689	<b>1051007-1</b>

**Right-Angle Cable Plug, Crimp**

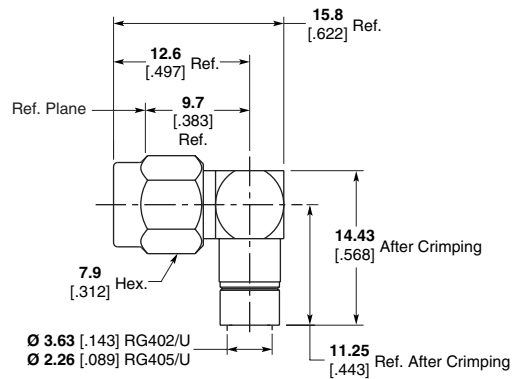

Cable Type RG/U	Body Material & Finish	Contact Captivation	Contact Attachment	Crimp Tooling Part No.	Instruction Sheet	Part No.
402 (3.58 [.141])	Stainless, Pass.	Mechanical	Solderless	1055835-1	408-4691	<b>1051145-1</b>
405 (2.16 [.085])	Stainless, Pass.	Mechanical	Solderless	1055835-1	408-4692	<b>1051147-1</b>

**Note:** Part Numbers are RoHS compliant except: ♦ Indicates non-RoHS compliant.

**SMA Connectors (Continued)**  
**Panel Mount, Solder Pot Terminal**

**4 Hole Flange Mount Plug Receptacle**

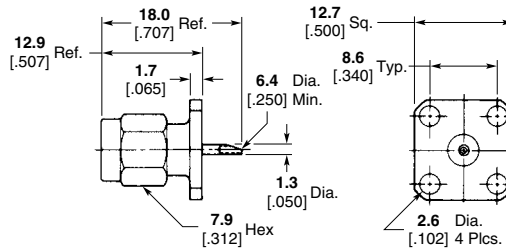

Body Material & Finish	Contact Captivation	RF Leakage db min.	Temperature Range	Part No.
Stainless, Passivated	Epoxy	N/A	-65 to 125° C	1052324-1

**4 Hole Flange Mount Jack Receptacle**

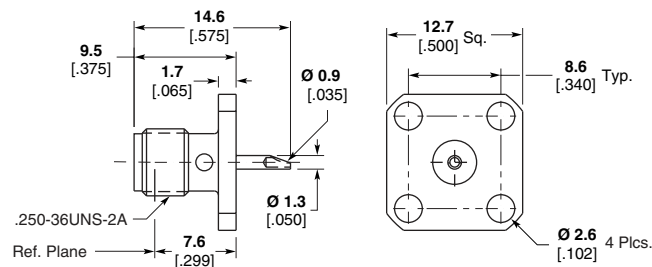

Body Material & Finish	Contact Captivation	RF Leakage db min.	Temperature Range	Part No.
Stainless, Passivated	Epoxy	-(60-fGHz)	-65 to 125° C	1052422-1

**2 Hole Flange Mount Jack Receptacle**

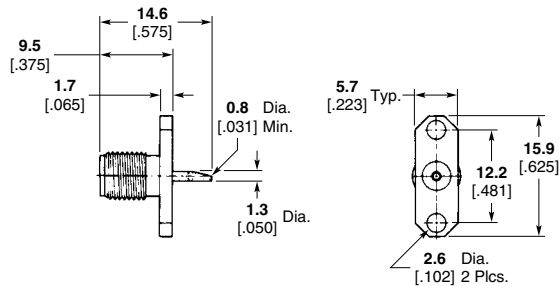

Body Material & Finish	Contact Captivation	RF Leakage db min.	Temperature Range	Part No.
Stainless, Passivated	Epoxy	-(60-fGHz)	-65 to 125° C	1052544-1

**2 Hole Flange Mount Jack Receptacle**

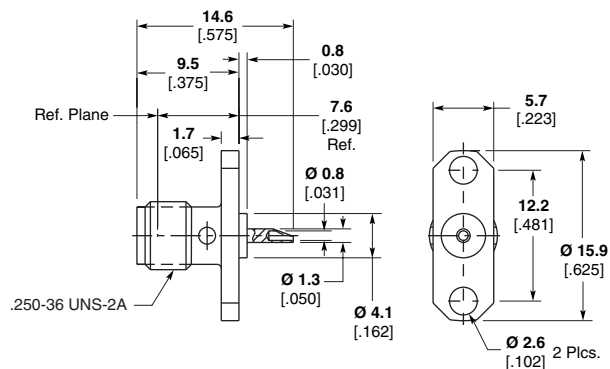

Body Material & Finish	Contact Captivation	RF Leakage db min.	Temperature Range	Part No.
Stainless, Passivated	Epoxy	-(60-fGHz)	-65 to 125° C	1052534-1

**Note:** Part Numbers are RoHS compliant except: ♦ Indicates non-RoHS compliant.

**SMA Connectors (Continued)**  
**Panel Mount**

**Bulkhead Feedthrough Jack Receptacle, Solder Pot Terminal**

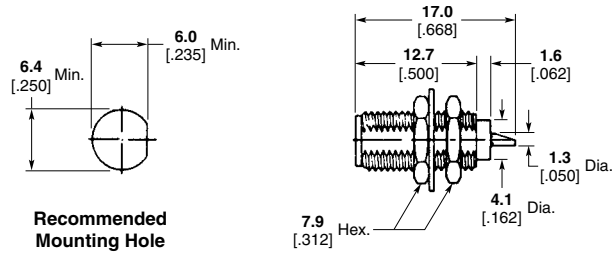

**Recommended Mounting Hole**

Body Material & Finish	Contact Captivation	RF Leakage db min.	Temperature Range	Part No.
Stainless, Passivated	Epoxy	N/A	-65 to 125° C	1053092-1

**Press-In Jacks, Straight Terminal**

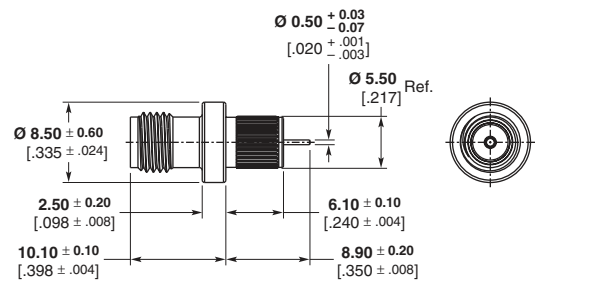

**Part Number 1460468**

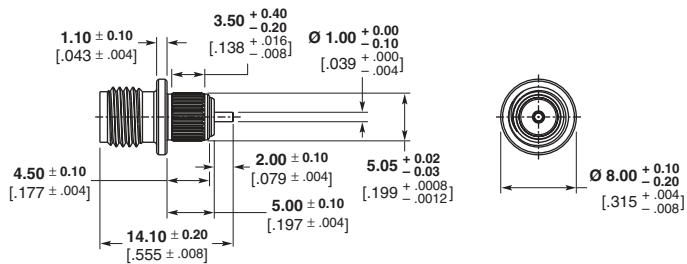

**Part Number 1460469**

Body Material & Finish	Contact Captivation	RF Leakage db min.	Temperature Range	Part No.
Brass, White Bronze	Mechanical	N/A	-65 to 125° C	1460468-1
Brass, Gold	Mechanical	N/A	-65 to 125° C	1460469-1

**Press-In Cable, Jack Panel**

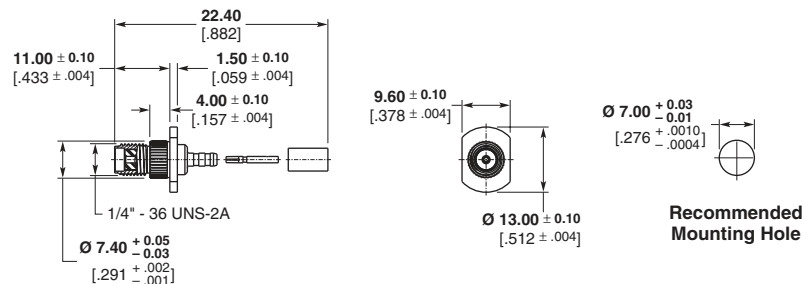

**Recommended Mounting Hole**

**Note:** Part Numbers are RoHS compliant except: ♦ Indicates non-RoHS compliant.

Cable Type RG/U	Body Material & Finish	Contact Captivation	Temperature Range	Part No.
316 D	Brass, Gold	Mechanical	-65 to 125° C	619115-1

**SMA Connectors (Continued)**  
**Panel Mount, Straight Terminal**

**4 Hole Flange Mount Jack Receptacle**

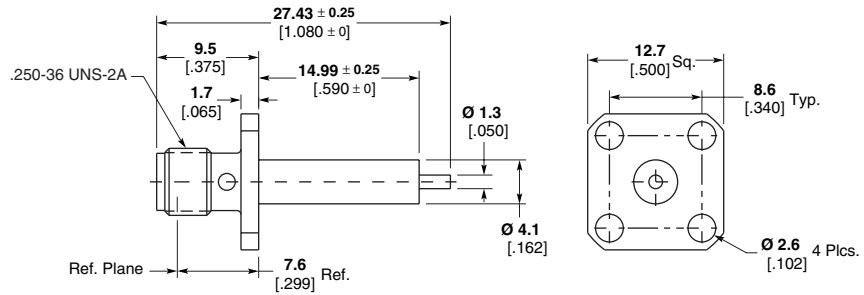

Body Material & Finish	Contact Captivation	RF Leakage db min.	Temperature Range	Part No.
Stainless, Passivated	None	-(100-fGHz)	-65 to 165° C	1052518-1
Stainless, Passivated	Epoxy	-(60-fGHz)	-65 to 125° C	1052523-1
Stainless, Gold	Epoxy	-(60-fGHz)	-65 to 125° C	1052522-1

**2 Hole Flange Mount Plug Receptacle**

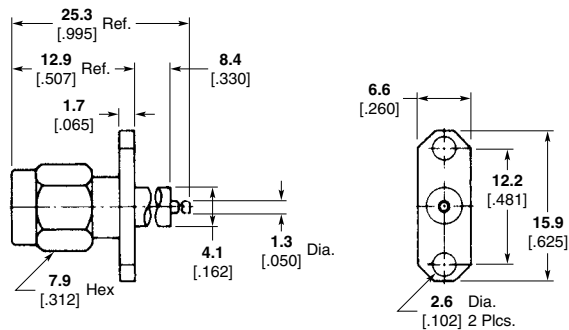

Body Material & Finish	Contact Captivation	RF Leakage db min.	Temperature Range	Part No.
Stainless, Passivated	Epoxy	-(60-fGHz)	-65 to 125° C	1052349-1

**2 Hole Flange Mount Jack Receptacle**

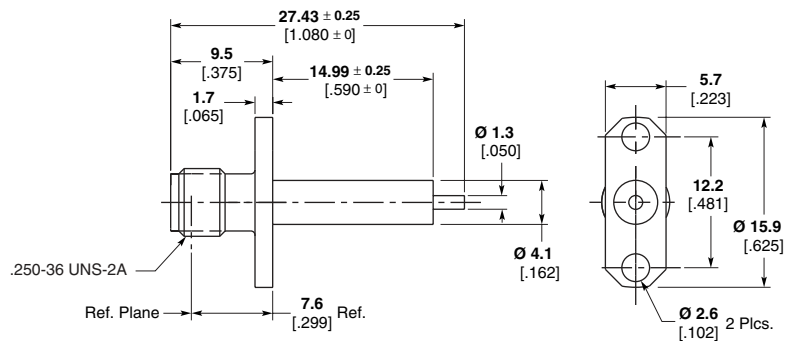

Body Material & Finish	Contact Captivation	RF Leakage db min.	Temperature Range	Part No.
Stainless, Passivated	Epoxy	-(60-fGHz)	-65 to 125° C	1052552-1

**Note:** Part Numbers are RoHS compliant except: ♦ Indicates non-RoHS compliant.

**SMA Connectors (Continued)**  
**Panel Mount, Straight Terminal (Continued)**

**Bulkhead Feedthrough Jack Receptacle**

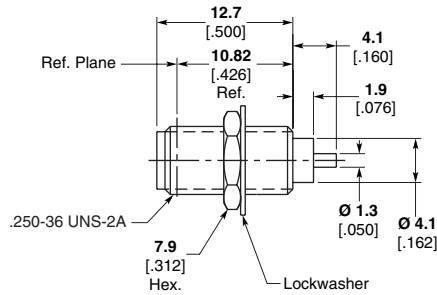

Body Material & Finish	Contact Captivation	RF Leakage db min.	Temperature Range	Part No.
Stainless, Passivated	Epoxy	-(60-fGHz)	-65 to 125° C	1053222-1

**2 Hole Flange Mount Right-Angle Jack Receptacle**

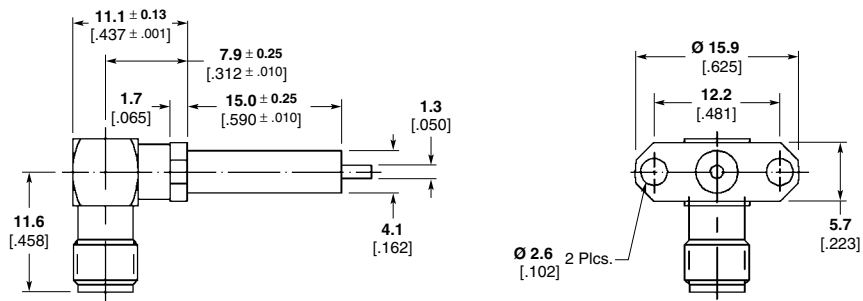

Body Material & Finish	Contact Captivation	RF Leakage db min.	Temperature Range	Part No.
Stainless, Passivated	Mechanical	-(90-fGHz)	-65 to 165° C	1052986-1

**4 Hole Flange Mount Right-Angle Jack Receptacle**

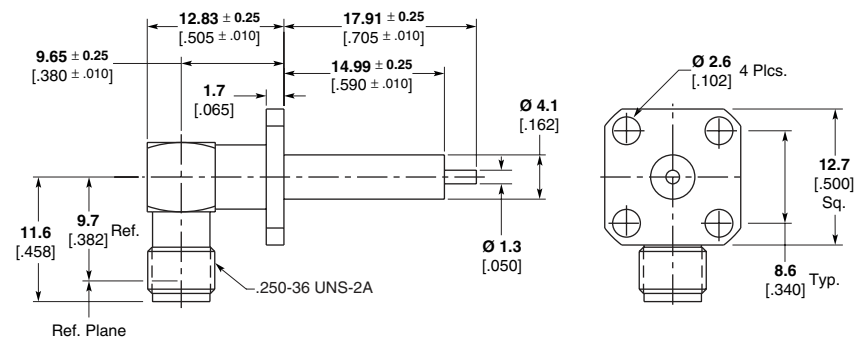

Body Material & Finish	Contact Captivation	RF Leakage db min.	Temperature Range	Part No.
Stainless, Passivated	Mechanical	-(90-fGHz)	-65 to 165° C	1052978-1
Stainless, Passivated	Mechanical	-(90-fGHz)	-65 to 165° C	1052982-1

**Note:** Part Numbers are RoHS compliant except: IIndicates non-RoHS compliant.



**SMA Connectors (Continued)**  
**Panel Mount**

**4 Hole Flange Mount Jack Receptacle, Straight Terminal**

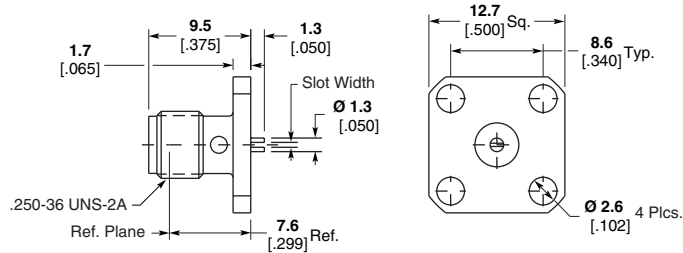

Body Material & Finish	Contact Captivation	Slot Width +.076/- .025 [+.003/- .001]	RF Leakage db min.	Temperature Range	Part No.
Stainless, Passivated	Epoxy	0.5 [.018]	-(60-fGHz)	-65 to 125° C	1052563-1

**4 Hole Flange Mount Plug Receptacle, Tab Terminal**

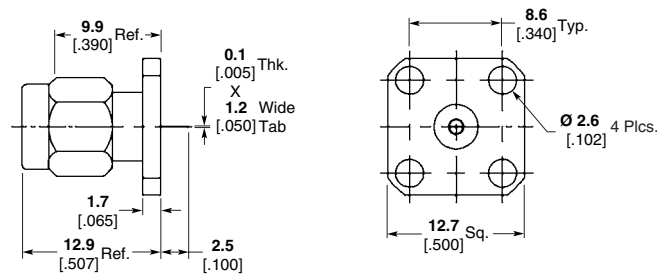

Body Material & Finish	Contact Captivation	Tab Width	RF Leakage db min.	Temperature Range	Part No.
Stainless, Passivated	Epoxy	1.3 [.050]	-(60-fGHz)	-65 to 125° C	1052360-1

**4 Hole Flange Mount Jack Receptacle, Tab Terminal**

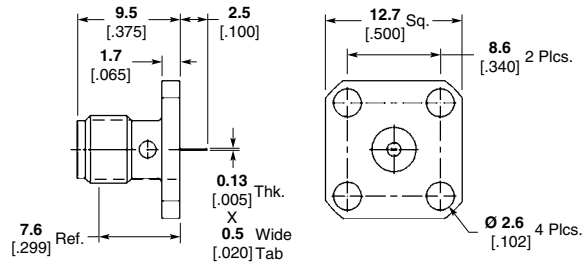

Body Material & Finish	Contact Captivation	Tab Width	RF Leakage db min.	Temperature Range	Part No.
Stainless, Passivated	Epoxy	.51 [.020]	-(60-fGHz)	-65 to 125° C	1052898-1

**Note:** Part Numbers are RoHS compliant except: ♦ Indicates non-RoHS compliant.

**SMA Connectors** (Continued)

**2 Hole Flange Mount Jack Receptacle, Panel Mount, Tab Terminal**

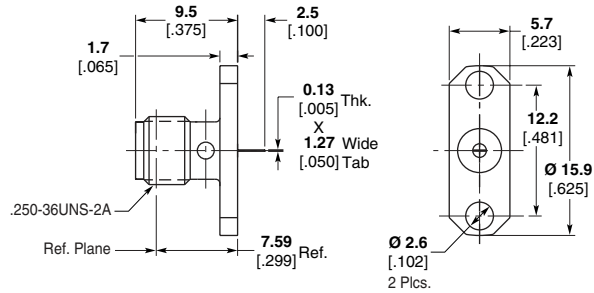

Body Material & Finish	Contact Captivation	Horizontal Tab	RF Leakage db min.	Temperature Range	Part No.
Stainless, Passivated	Epoxy	↙	-(60-fGHz)	-65 to 125° C	1052577-1

**4 Hole Flange Mount Jack Receptacle, for Microstrip Transmission Line Circuits**

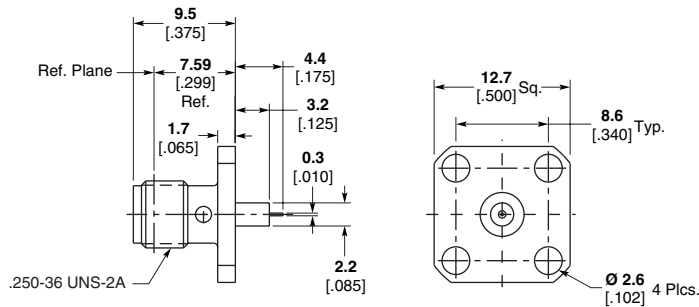

Body Material & Finish	Contact Captivation	RF Leakage db min.	Temperature Range	Part No.
Stainless, Passivated	Epoxy	-(60-fGHz)	-65 to 125° C	1052528-1

**2 Hole Flange Mount Jack Receptacle, for Microstrip Transmission Line Circuits**

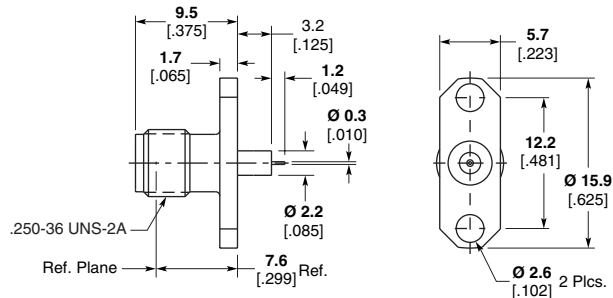

Body Material & Finish	Contact Captivation	RF Leakage db min.	Temperature Range	Part No.
Stainless, Passivated	Epoxy	-(60-fGHz)	-65 to 125° C	1052902-1

**Note:** Part Numbers are RoHS compliant except: ♦ Indicates non-RoHS compliant.

**SMA Connectors (Continued)**  
**Field Replaceable Hermetic Launchers (Continued)**

**4 Hole Flange Mount Jack Receptacle with EMI/RFI Gasket**

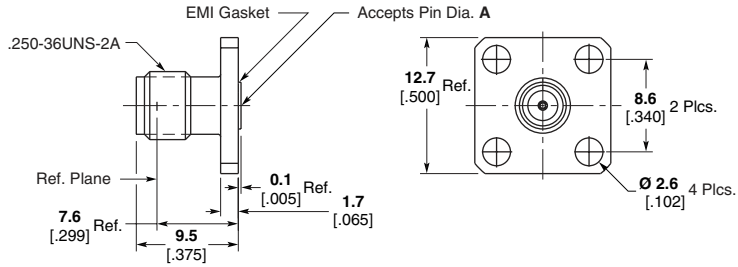

Material & Finish	Captivation	Pin Diameter A	Part No.
Stainless, Passivated	Mechanical	.38 [0.015]	<b>1052684-1</b>

**4 Hole Flange Mount Jack Receptacle without EMI/RFI Gasket**

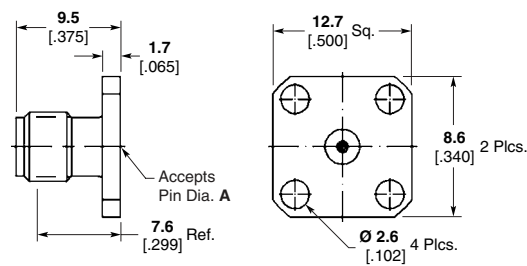

Material & Finish	Captivation	Pin Diameter A	Part No.
Stainless, Passivated	Mechanical	.91 [0.036]	<b>1052643-1</b>

**2 Hole Flange Mount Jack Receptacle with EMI/RFI Gasket**

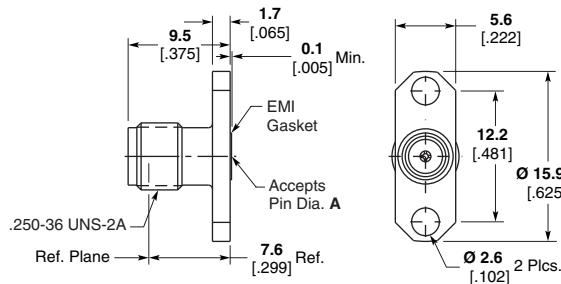

Material & Finish	Captivation	Pin Diameter A	Part No.
Stainless, Passivated	Mechanical	.30 [0.012]	<b>1052628-1</b>
Stainless, Passivated	Mechanical	.38 [0.015]	<b>1052689-1</b>
Stainless, Passivated	Mechanical	.46 [0.018]	<b>1052634-1</b>

**2 Hole Flange Mount Jack Receptacle without EMI/RFI Gasket, Field Replaceable Hermetic Launchers**

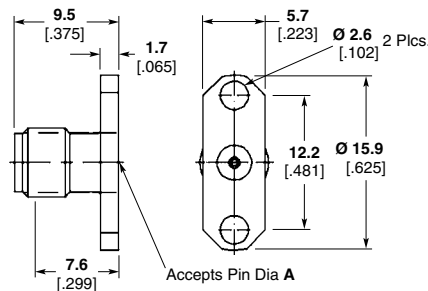

Material & Finish	Captivation	Pin Diameter A	Part No.
Stainless, Passivated	Mechanical	.51 [0.020]	<b>1052652-1</b>
Stainless, Passivated	Mechanical	.91 [0.036]	<b>1052646-1</b>

**Note:** Part Numbers are RoHS compliant except: ♦ Indicates non-RoHS compliant.

**SMA Connectors (Continued)**

**PC Board Mount  
Vertical Jack**

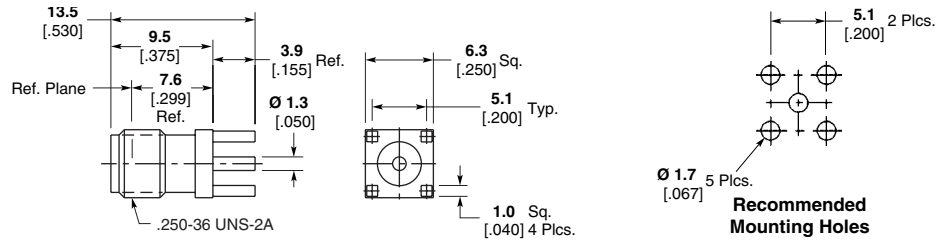

Style 1

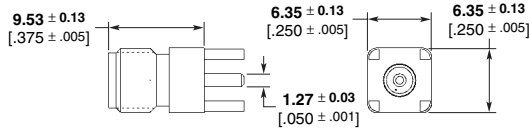

Style 2

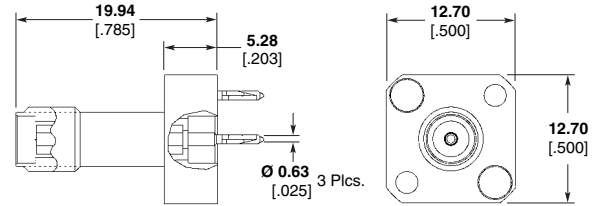

Style 3

Material & Finish	Style No.	Part No.
Stainless, Gold	1	1053354-1
Brass, Gold	2	221789-1
Brass, Gold	2	221789-3
Brass, Nickel Plate	3	6274096-1

**PC Board Mount  
Right-Angle Jack**

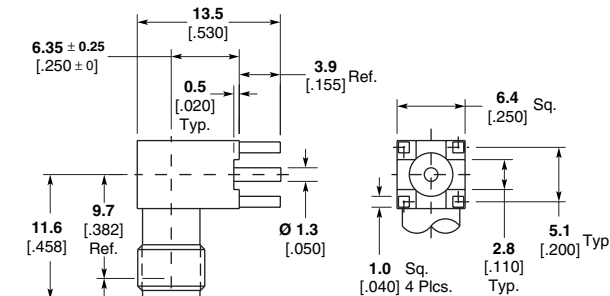

Style 1

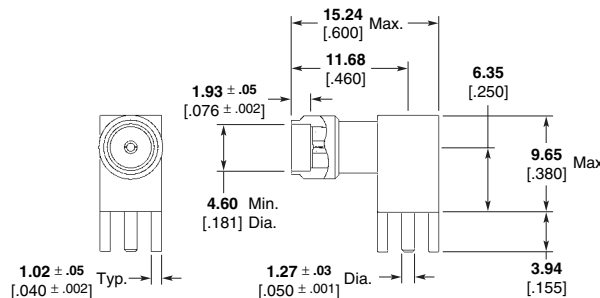

Style 2

Material & Finish	Style No.	Part No.
Stainless, Gold	1	1053378-1
Stainless, Gold	2	221790-1

Note: Part Numbers are RoHS compliant except: ♦ Indicates non-RoHS compliant.

**SMA Connectors (Continued)**

**In-Series Adapter,  
Jack to Jack**

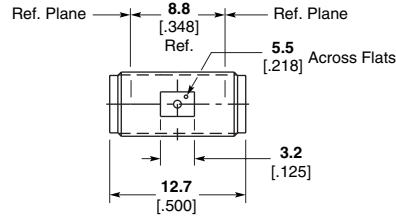

Frequency	Material & Finish	Captivation	Part No.
DC-18.0GHz	Stainless, Gold	Epoxy*	<b>1053488-1</b>

**In-Series Adapter,  
Plug to Plug**

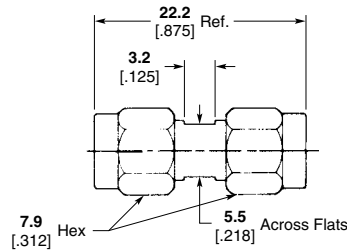

Frequency	Material & Finish	Captivation	Part No.
DC-18.0GHz	Stainless, Passivated	Epoxy*	<b>1053635-1</b>

\*All adapters listed above employ epoxy captivation. Mechanically captivated versions are also available. Please consult Tyco Electronics.

**In-Series Adapter,  
Jack to Plug, Right-Angle**

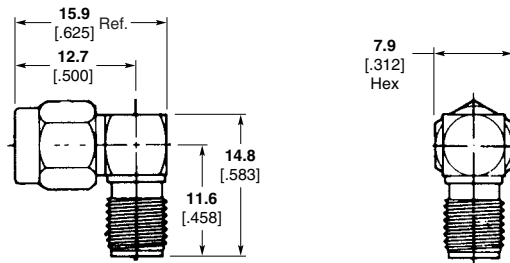

Frequency	Material & Finish	Captivation	Part No.
DC-12.4GHz	Stainless, Passivated	Mechanical	<b>1055065-1</b>

**In-Series Adapter,  
Jack to Jack, Right-Angle**

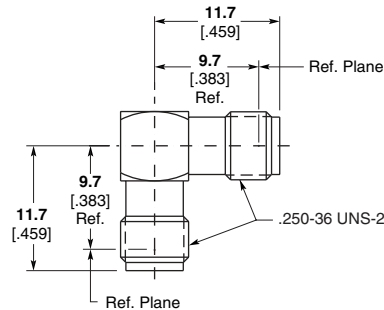

Frequency	Material & Finish	Captivation	Part No.
DC-12.4GHz	Stainless, Passivated	Mechanical	<b>1055018-1</b>

**Note:** Part Numbers are RoHS compliant except: ♦ Indicates non-RoHS compliant.

**SMA Connectors** (Continued)

**In-Series Adapter,  
Plug to Plug, Right-Angle**

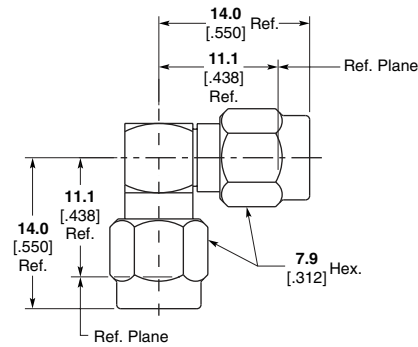

Frequency	Material & Finish	Captivation	Part No.
DC-18.0GHz	Stainless, Passivated	Mechanical	<b>1055047-1</b>

**In-Series Adapter,  
Jack to Plug, Connector Saver**

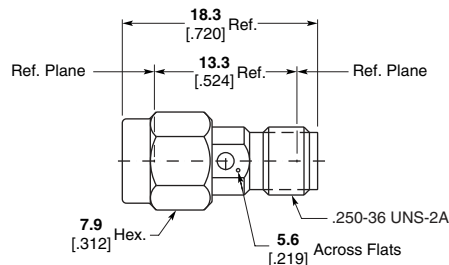

Frequency	Material & Finish	Captivation	Part No.
DC-18.0GHz	Stainless, Passivated	Epoxy	<b>1054426-1</b>

**In-Series Adapter,  
Jack to Jack,  
Bulkhead Feedthrough**

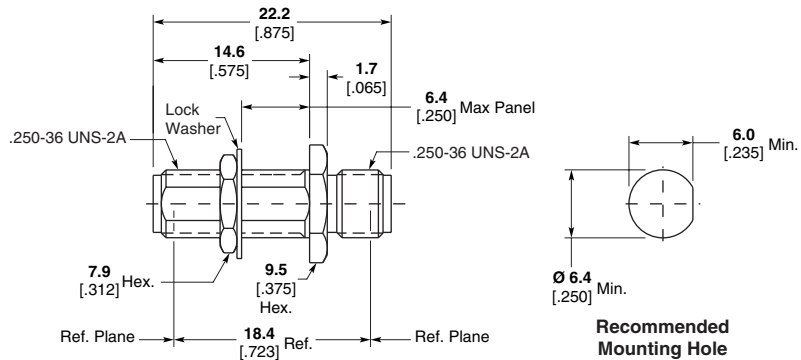

Frequency	Material & Finish	Captivation	Part No.
DC-18.0GHz	Stainless, Passivated	Epoxy*	<b>1054869-1</b>

\*Mechanically captivated version available. Please consult Tyco Electronics.

**Test Adapter,  
Plug to Jack,  
Quick Release**

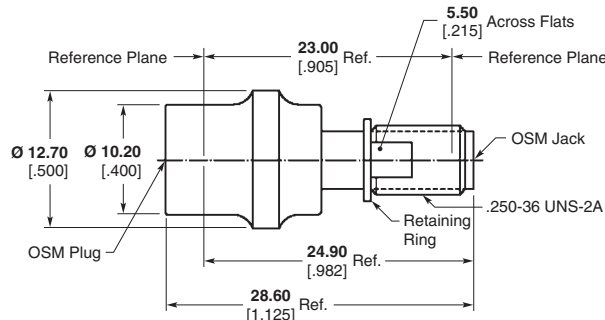

Frequency	Material & Finish	Captivation	Part No.
DC-18.0GHz	Stainless, Passivated	Epoxy	<b>1053780-1</b>

**Note:** Part Numbers are RoHS compliant except: ♦ Indicates non-RoHS compliant.

## QMA Connectors

### Snap-On SMA Series of RF Connectors

#### Product Facts

- Positive snap-on interface facilitates assembly
- Intermateable with competitor product
- Excellent RF performance to 6 GHz
- Ideal for Communications and Industrial Applications



Tyco Electronics' next generation high performance RF products QMA (Snap-On SMA) connectors series offers the same high quality and performance currently found in the standard Tyco Electronics SMA series but does not require the coupling nut torque.

By integrating a snap-on feature to the design, denser packaging can be achieved, and the overall applied cost is dramatically reduced. The QMA connector series is excellent for communications as well as industrial applications. The QMA offering is designed for 100 mating cycles, operates through 6 GHz, and is completely intermateable with competitive QMA offerings. This new QMA product is not intermateable with standard SMA interfaces.

QMA connectors are available in a broad range of standard configurations,

including PCB and panel mount, flexible and semi-rigid cable, and adapters. Other options can be reviewed as well, including additional cable sizes, PCB surface mounting, and tape and reel packaging.

The QMA connector series is a cost effective solution for the challenging demands of today's commercial marketplace, with applications including cellular base station, handsets, and test and measurement. Call your local sales office or authorized distributor for additional information or samples of the QMA connector series.

Tyco Electronics is a leading supplier of RF and Microwave connectors and cable assemblies, and provides advanced technology products from well known and industry leading brands, including AMP and M/A-COM.

#### Material and Finish

**Shells and Bodies** — Brass, nickel plated

**Collars** — Phosphor bronze, white bronze plated

**Outer Contacts** — Beryllium copper, nickel plated

**Center Contacts** — Beryllium copper, gold plated

**Dielectrics** — PTFE

#### Electrical Characteristics

**Frequency** — dc – 6 GHz

**Nominal Impedance** — 50 ohms

**Voltage Rating** — 335 Volts (VRMS max.) @ Sea Level

**VSWR** — 1.15 : 1 max. @ 6 GHz

**Insulation Resistance** — 5,000 megohms min.

**Insertion Loss** — .25 dB Max @ 6 GHz

**Dielectric Withstanding Voltage** — 1000 Volts (VRMS max.) @ Sea Level

**Contact Resistance** —

Center Contact — 5 milliohms max.

Outer Contact — 4 milliohms max.

#### Mechanical Characteristics

**Connector Durability** —

100 mating cycles

**Force to Engage** — 27 Newtons

**Force to Disengage** — 20 Newtons

**Retention Force (mated pair)** — 60 Newtons min.

**Cable Retention** — Dependent upon cable type

#### Environmental Characteristics

**Temperature Rating** —

-40 to +125°C

**Vibration** — EIA-364-28, Test Condition VII, Condition D

**Shock** — EIA-364-27, Method H

**Moisture Resistance** — EIA-364-31, Method III

**Thermal Shock** — EIA-364-32

**Note:** Performance specifications are typical, but may not apply to all connector types.

#### Related Product Data

**Product Specification** — 108-2087

**Sample Kit** — 1654882

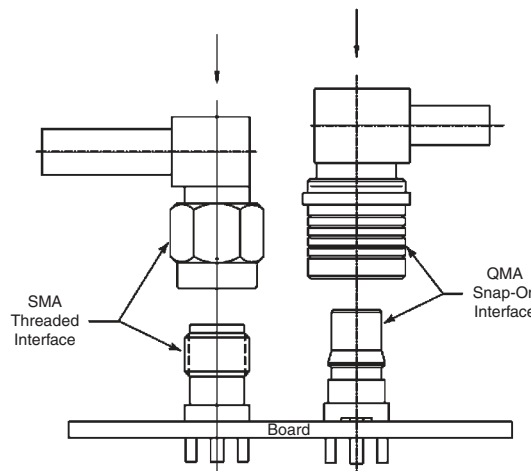



**QMA Connectors** (Continued)

**Semi-Rigid Cable —  
Direct Solder Attachment**

**Straight Cable Plug**

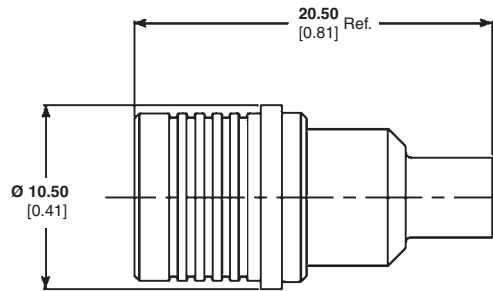

Cable	Part Number
RG 402	1408346-1

**Right-Angle Cable Plug**

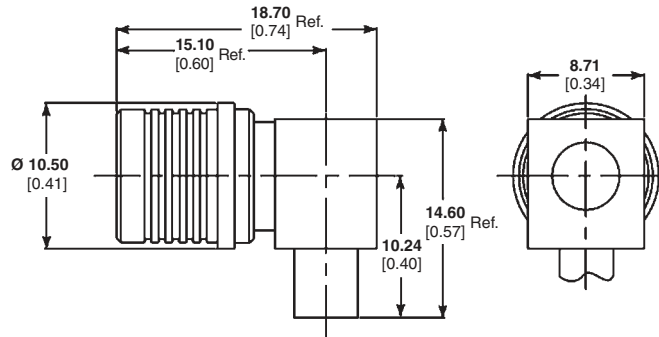

Cable	Part Number
RG 402	1408347-1

**Straight Cable Jack**

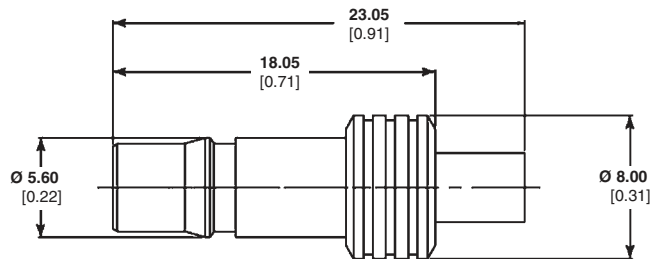

Cable	Part Number
RG 402	1408348-1

**Bulkhead Cable Jack**

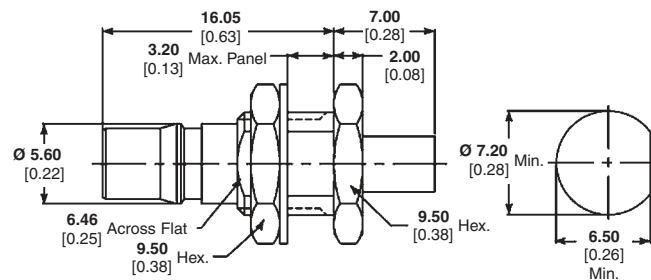

Cable	Part Number
RG 402	1408349-1

**Note:** Part Numbers are RoHS compliant except: ♦ Indicates non-RoHS compliant.

**QMA Connectors (Continued)**

**Flexible Cable — Crimp Attachment**

**Straight Cable Plug**

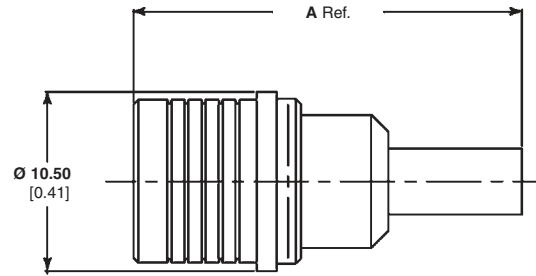

Cable	Dim. A	Part Number
RG 174, 188, 316	22.90 0.90	1408333-1
RD 316	22.90 0.90	1408333-3
RG 400	25.20 0.99	1408333-5
RG 58	25.20 0.99	1408333-7

**Right-Angle Cable Plug**



Cable	Dim. A	Dim. B	Part Number
RG 174, 188, 316	17.20 0.68	13.10 0.52	1408336-1
RD 316	17.20 0.68	13.10 0.52	1408336-3
RG 400	19.50 0.77	15.40 0.61	1408336-5
RG 58	19.50 0.77	15.40 0.61	1408336-7

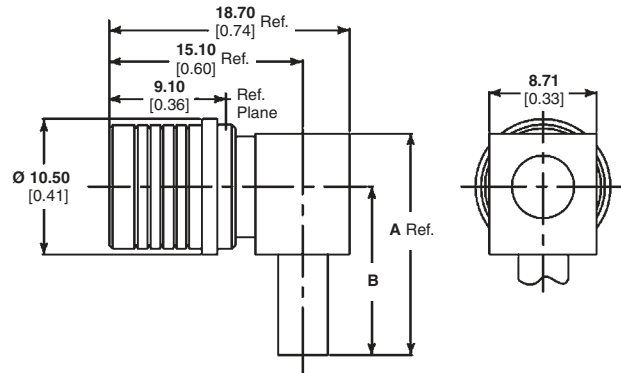

**Straight Cable Jack**



Cable	Dim. A	Part Number
RG 174, 188, 316	25.90 1.02	1408338-1
RD 316	25.90 1.02	1408338-3
RG 400	28.20 1.11	1408338-5
RG 58	28.20 1.11	1408338-7

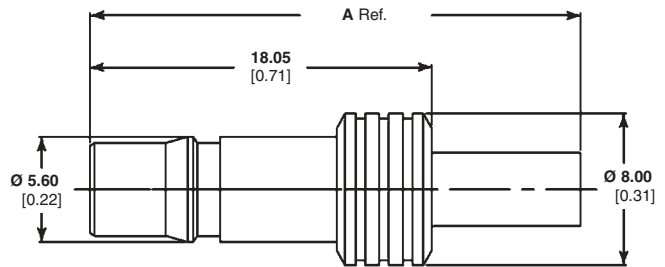

**Bulkhead Cable Jack**

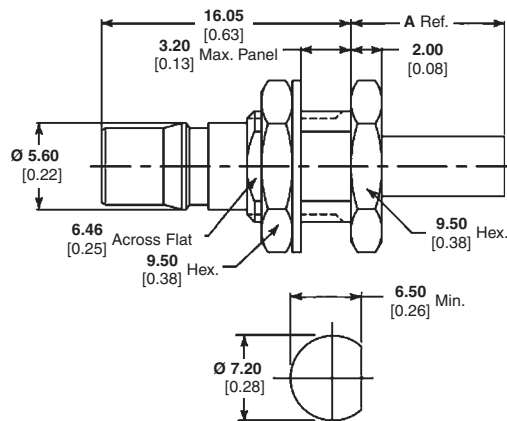

Cable	Dim. A	Part Number
RG 174, 188, 316	9.90 0.39	1408339-1
RD 316	9.90 0.39	1408339-3
RG 400	12.20 0.48	1408339-5
RG 58	12.20 0.48	1408339-7

**Note:** Part Numbers are RoHS compliant except: ♦ Indicates non-RoHS compliant.

**Recommended Mounting Hole**

**QMA Connectors (Continued)**

**Printed Circuit Board**

**Straight Jack Receptacle**



<b>Part Number</b>
1408332-1

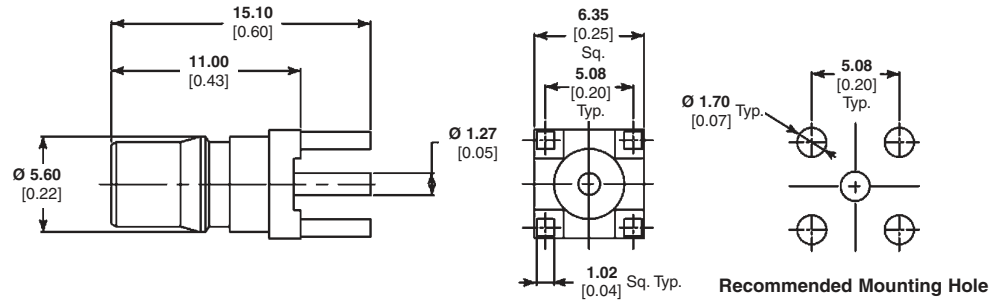

**Right-Angle Jack Receptacle**



<b>Part Number</b>
1408337-1

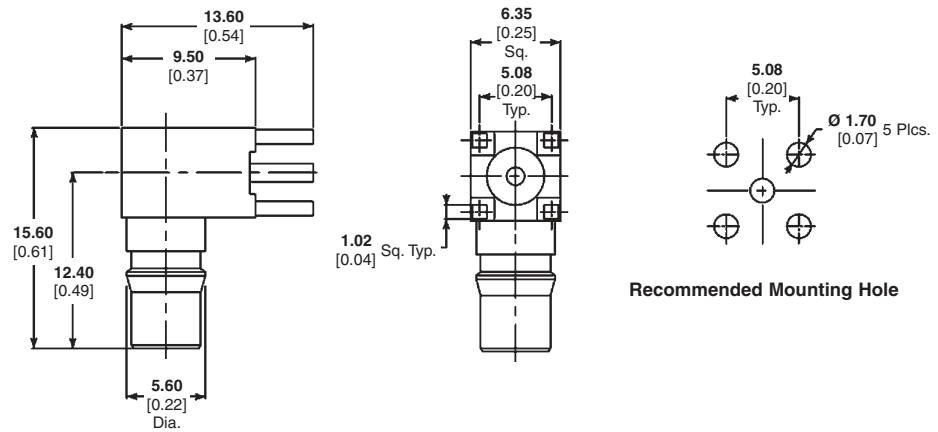

**Straight Terminal Press-In Jack**

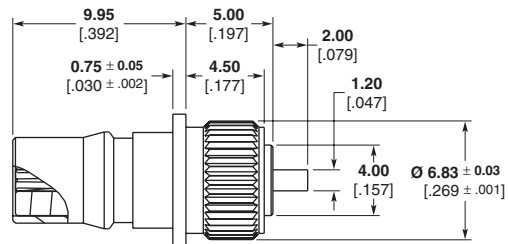

Body Material & Finish	Contact Captivation	RF Leakage db min.	Temperature Range	Part No.
Brass, Gold	Mechanical	N/A	-65 to 125° C	619215-1

**Note:** Part Numbers are RoHS compliant except: I Indicates non-RoHS compliant.

**QMA Connectors (Continued)**

**Straight Terminal**

**4-Hole Flange Mount Jack Receptacle**

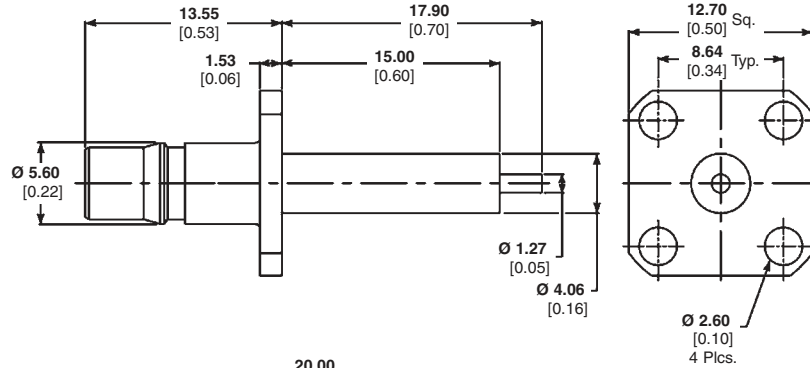

Part Number  
1408341-1

**Screw-In Front Mount Jack Receptacle**

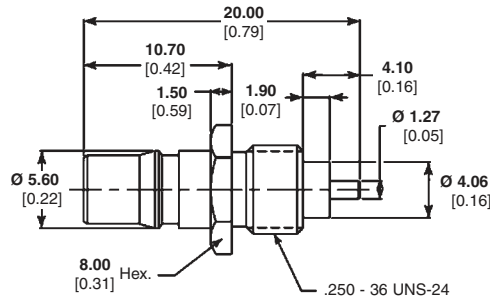

Part Number  
1408340-1

**Adapters — In Series**

**QMA Plug to QMA Jack**

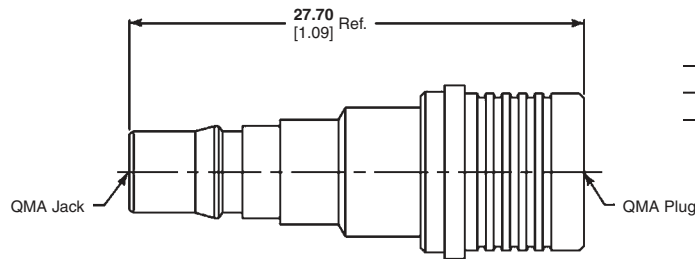

Part Number  
1408342-1

**Adapters — Between Series**

**QMA Plug to SMA Plug**

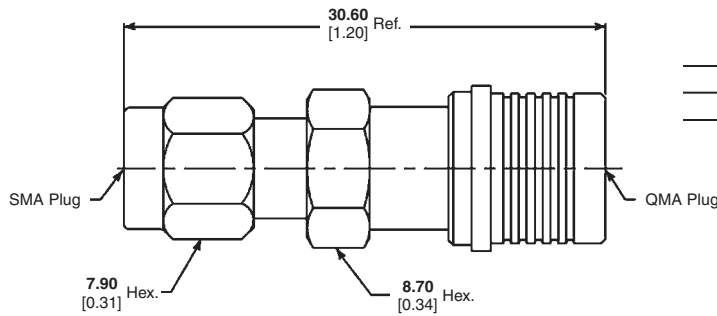

Part Number  
1408393-1

**QMA Jack to SMA Plug**

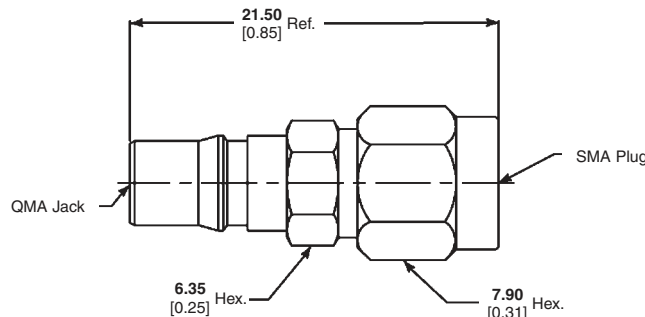

Part Number  
1408343-1

**Note:** Part Numbers are RoHS compliant except: ♦ Indicates non-RoHS compliant.

**Series 1.0/2.3 (50 Ohm/75 Ohm)**



Miniature coaxial connectors series 1.0/2.3 (CECC 22230 and IEC 61169-29) coaxial connectors are devised to meet the requirements of compact electronic instrumentation. All plugs and jacks with  $Z_0 = 50 \Omega$  are designed for a number of different 50  $\Omega$  and 75  $\Omega$  cables. Owing to the large demand, the Series 1.0/2.3 has also been optimized as a 75  $\Omega$  design into the GHz range. The different types of coupling mechanisms, such as screw on, slide-in and latching coupling permit space-saving installation. In addition, an extensive range of measurement

accessories, adapters as well as terminations is available. The quality-determining factors have been established on the basis of corresponding measurements and test procedures in accordance with national and international standards for RF connectors (IEC 61169-1, MIL-C-39012 etc.). High-quality materials ensure high reliability even in industrial atmospheres. The contact principle is the pin-socket principle and the contacts are gold plated to ensure perfect contact mating. The inner conductor parts are held in PTFE (Polytetrafluoroethylene).

The reduced dimensions of all component parts of these connectors permit a compact hole spacing (installation pitch) of 6.8 [0.27] depending upon the corresponding cable diameters. The cable is connected by crimping the cable braid to the plug or jack body, the inner conductor is soldered or crimped. In most applications, the plug and jack belong to the same coupling type group. In special instances, such as for measurement purposes, different coupling types can be used together.

**Between Series Adapters**

For Series 1.0/2.3 Adapters please see pages 251-260.

**Series 1.0/2.3 (50 Ohm/75 Ohm) (Continued)**

**Technical Data**

**Electrical and mechanical characteristics in accordance with CECC 22230**

**Characteristic impedance** —  
50 Ω/75 Ω

**Frequency range** — up to 10 GHz/  
2 GHz

**Reflection factor, referred to 50 Ω cable<sup>1</sup>** —

up to 1 GHz,  $r \leq 0.05$   
up to 4 GHz,  $r \leq 0.07$   
up to 10 GHz,  $r \leq 0.15$

**Reflection factor, referred to 75 Ω cable<sup>1</sup>** —

up to 2 GHz,  $r \leq 0.10$

**Insulation resistance** —

initial value  $\geq 1 \text{ G}\Omega$   
after stressing  $\geq 200 \text{ M}\Omega$

**Screening effectiveness<sup>2</sup>** —  
 $\geq 90 \text{ dB}$

**Inner conductor contact resistance**  
— after stressing  $\leq 10 \text{ m}\Omega$

**Outer conductor continuity** —  
after stressing  $\leq 7.5 \text{ m}\Omega$

**Voltage proof<sup>3</sup>** —  
flexible cables (RG 316)  
— at sea level, 750 V, 50 Hz  
— at 20 km altitude, 150 V, 50 Hz

**Working voltage<sup>3</sup>** —  
flexible cables (RG 316)  
— at sea level, 350 V, 50 Hz  
— at 20 km altitude, 65 V, 50 Hz

**Service life** — 500 cycles

**Climatic category** — 40/85/21

**Notes:**

- <sup>1</sup> Guide values, depending on cable type and connector style.
- <sup>2</sup> Values apply to a straight screw and latching coupling with suitable cable.
- <sup>3</sup> Some cables suitable for use with these connectors have lower characteristic values than specified here.
- <sup>4</sup> For applicable cable types see page 151.

**Coupling Types**

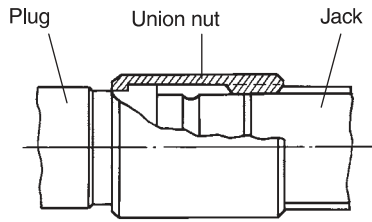

**Type A**

Screw coupling; version with union nut

This type permits the plug and jack to be screwed together manually by means of a union nut secured to the plug. This is necessary for readily accessible locations, front panel test points and cable connections.

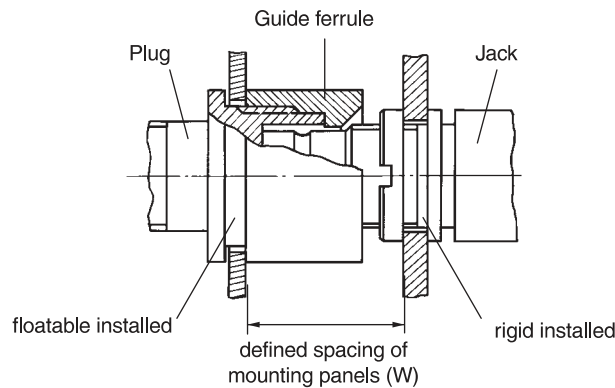

**Type C**

Slide-in coupling; version with centering ferrule

In this type of coupling, the plug features a guide ferrule with a conical entry surface. This ensures that the floatable bulkhead plugs with cable connection make a reliable electrical connection to the rigid installed jack. Examples of this are single and multi-contact connections of slide-in applications. "W" denotes the allowed spacing of the mounting panel for satisfactory contact when the connection is made.

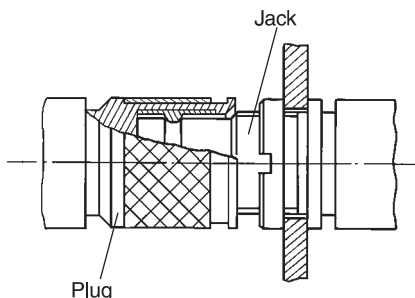

**Type F**

Latching coupling (Quick Lock)

In this version, the cable plugs bear a funnel ferrule with built-in spring which snaps into a groove on the jack, simultaneously locking the connection. The connec-

tion can be easily separated by lightly pulling the outer sleeve of the plug. This type of coupling can be used with a higher packing density, as the screw coupling.

**Series 1.0/2.3, 50 Ohm**

**Plugs, Solder/Crimp**

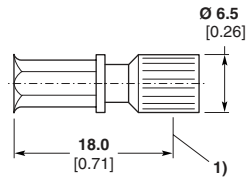

1) Detent for jack

Cable	Coupling Type	Ø Max.	Part No.
RG 316	A	2.67 0.105	1393670-1

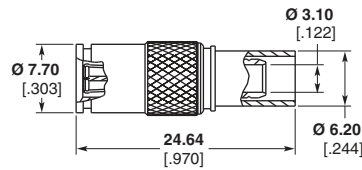

Cable	Coupling Type	Ø Max.	Part No.
WP93385L2	F	2.67 0.105	619223-1

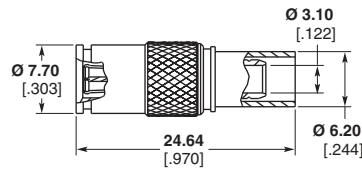

Cable	Coupling Type	Ø Max.	Part No.
LMR 240	F	2.67 0.105	619224-1

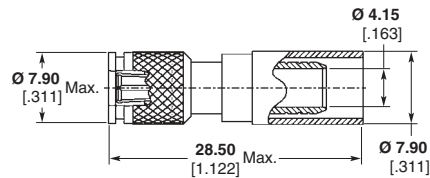

Cable	Coupling Type	Ø Max.	Part No.
LMR 240FR	F	6.3 0.248	1460010-1

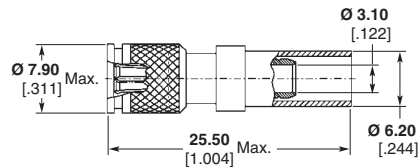

Cable	Coupling Type	Ø Max.	Part No.
WP93385L2	F	6.3 0.248	619085-1

**Note:** Part Numbers are RoHS compliant except: ♦ Indicates non-RoHS compliant.



**Series 1.0/2.3, 50 Ohm** (Continued)

**Bulkhead Jack,  
Solder/Crimp**

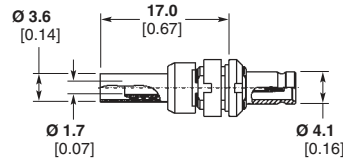

Cable	Coupling Type	Ø Max.	Part No.
RG 316	A, C, F	2.6 0.10	4-1393670-4

**Bulkhead Solder Jack**

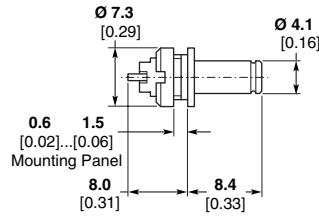

Coupling Type	Part No.
C, F	1393670-8

**Vertical PC Board  
Mount Jack**

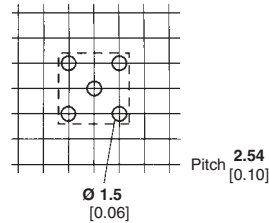
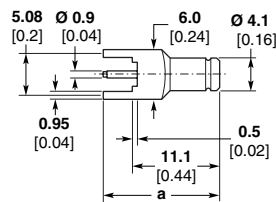

Coupling Type	Dim a	Part No.
C, F	14.6 0.57	3-1393670-4
C, F	15.6 0.61	3-1393670-5

Recommended Mounting Holes

**Vertical PC Board Mount  
Bulkhead Jack**

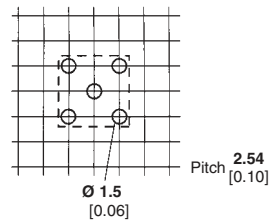
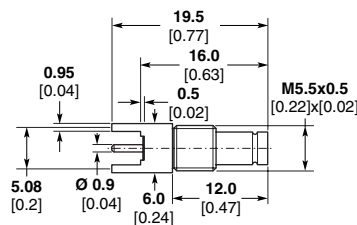

Coupling Type	Part No.
A, C, F	3-1393670-6

Recommended Mounting Holes

**Note:** Part Numbers are RoHS compliant except: ♦ Indicates non-RoHS compliant.

**Series 1.0/2.3, 50 Ohm (Continued)**

**Right-Angle PC Board Mount Bulkhead Jack**

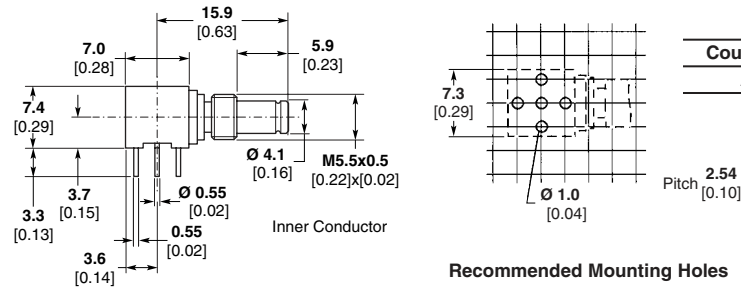

Coupling Type	Part No.
A, C, F	3-1393670-9

**Recommended Mounting Holes**

**Vertical PC Board Mount ACTION PIN Jack**

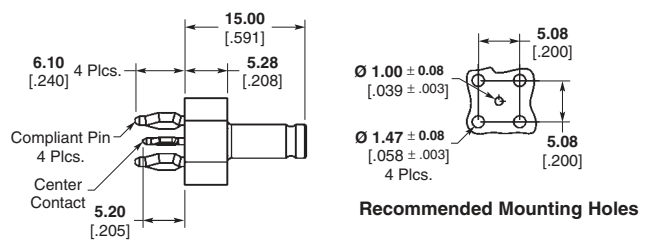

Coupling Type	Part No.
C, F	6274431-1

**Recommended Mounting Holes**

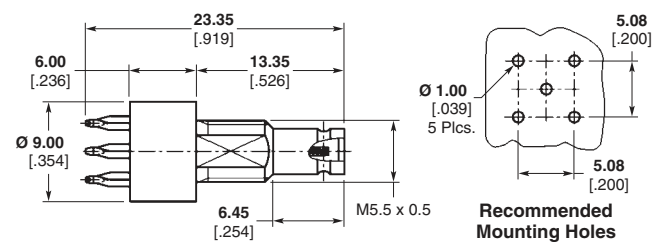

Coupling Type	Part No.
A, C, F	619107-1

**Recommended Mounting Holes**

**Panel Mount, Press-in, Launcher Jack**

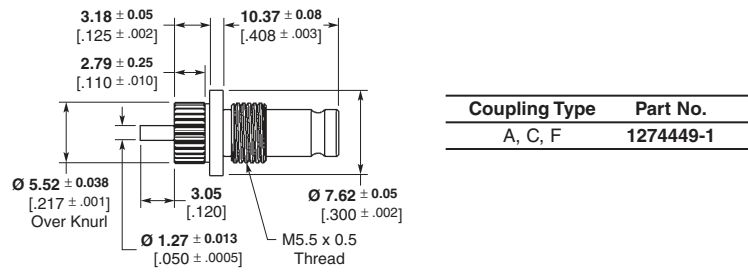

Coupling Type	Part No.
A, C, F	1274449-1

**Panel Mount, 4-Hole Flange, Launcher Jack**

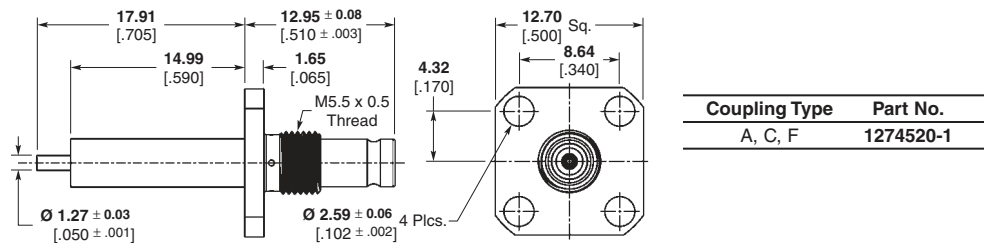

Coupling Type	Part No.
A, C, F	1274520-1

**Front Mount, Bulkhead Jack**

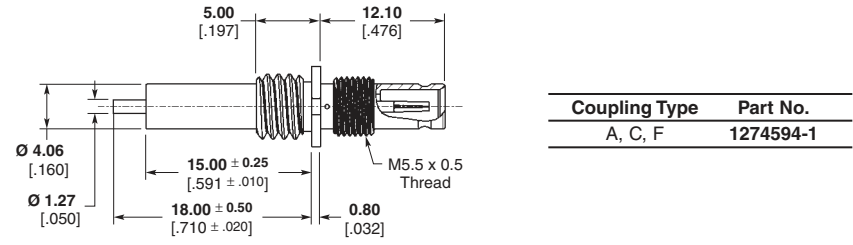

Coupling Type	Part No.
A, C, F	1274594-1

**Note:** Part Numbers are RoHS compliant except: ♦ Indicates non-RoHS compliant.

**Series 1.0/2.3, 50 Ohm (Continued)**

**Right-Angle PC Board  
Mount Bulkhead Jack**

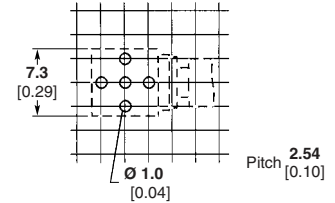
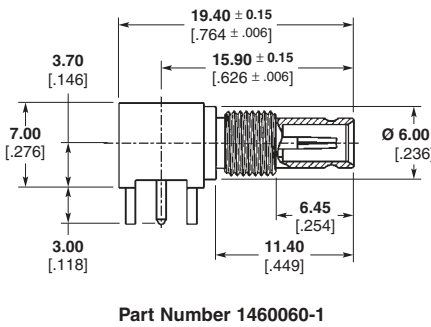
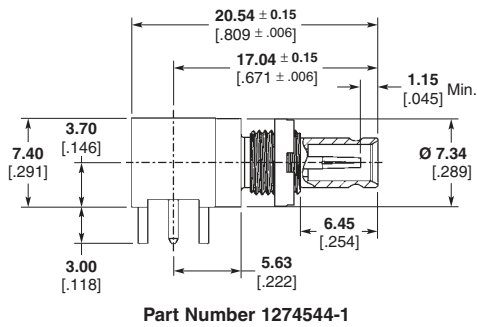

Coupling Type	Part No.
A, C, F	1274544-1
A, C, F	1460060-1

**Plating**

**Outer Body** — Silver

**Outer and Center Conductor** — Gold

Coupling Type	Part No.
A, C, F	1460139-1

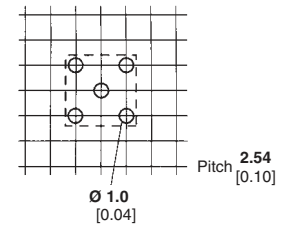
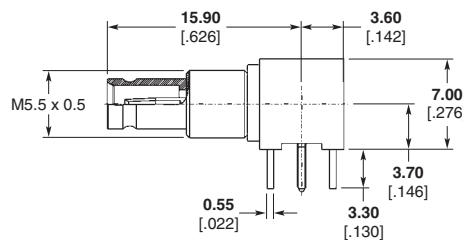

**Series 1.0/2.3, 75 Ohm**

**Plugs, Solder/Crimp**

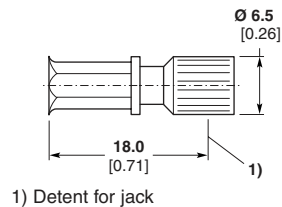

Cable	Coupling Type	Ø Max.	Part No.
RG 179	A	2.67 0.105	5-1393670-5

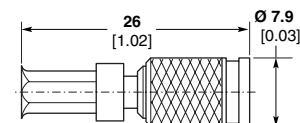

Cable	Coupling Type	Ø Max.	Part No.
RG 179	F	2.67 0.105	6-1393670-2
ST 212	F	3.2 0.13	6-1393670-5
02Y(ST)CY 0.45/2.0	F	3.6 0.14	6-1393670-4

**Note:** Part Numbers are RoHS compliant except: ♦ Indicates non-RoHS compliant.

**Series 1.0/2.3, 75 Ohm (Continued)**

**Straight Plugs, Solder/Crimp**

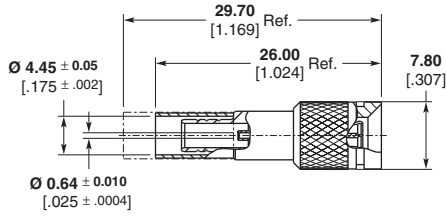

Cable	Coupling Type	Ø Max.	Part No.
BELDEN 1855A	A, C, F	2.67 0.105	619226-1

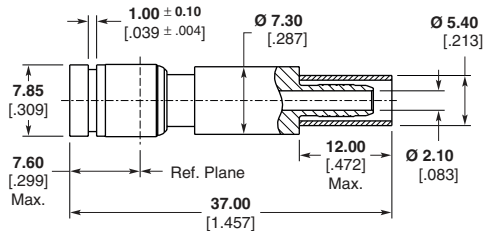

Cable	Coupling Type	Ø Max.	Part No.
BT 3002	A, C, F	2.67 0.105	1460815-1

**Right-Angle Plug, Solder/Crimp**

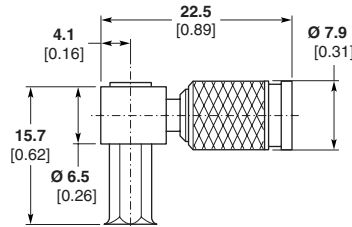

Cable	Coupling Type	Ø Max.	Part No.
RG 179	F	2.67 0.105	2-1393670-6
02Y(St)CY 0.45/2.0	F	3.6 0.14	7-1393670-0

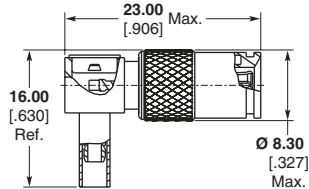

Cable	Coupling Type	Ø Max.	Part No.
RG 316	F	2.8 0.110	619228-1

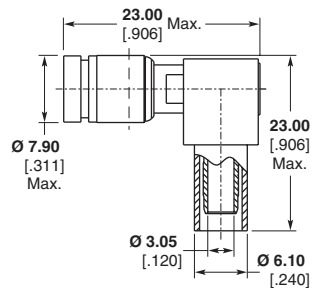

Cable	Coupling Type	Ø Max.	Part No.
RA 7000	A, C, F	2.67 0.105	1460817-1

**Bulkhead Jack, Solder/Crimp**

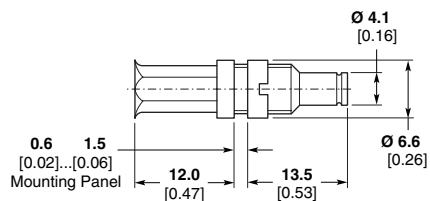

Cable	Coupling Type	Ø Max.	Part No.
RG 179	A, C, F	2.67 0.105	8-1393670-0

BELDEN is a trademark of Belden Wire and Cable Company.

**Note:** Part Numbers are RoHS compliant except: ♦ Indicates non-RoHS compliant.

**Series 1.0/2.3, 75 Ohm** (Continued)

**Right-Angle Bulkhead Jack, Solder/Crimp**

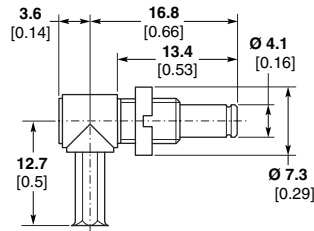

Cable	Coupling Type	Ø Max.	Part No.
RG 179, 316	A, C, F	2.67 0.105	3-1393670-2

**Vertical PC Board Mount Bulkhead Jack**

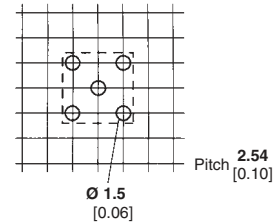
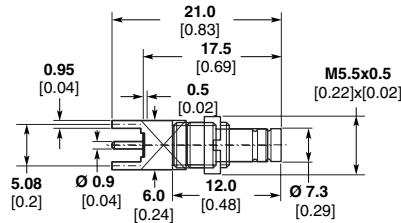

Recommended Mounting Holes

Coupling Type	Part No.
A, C, F	8-1393670-3

**PC Board Mount Bulkhead Jack**

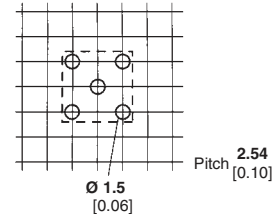
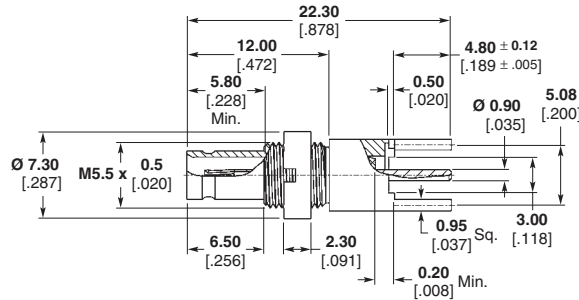

Recommended Mounting Holes

Coupling Type	Ø Max.	Part No.
A, C, F	1.00-2.30 .039-.091	619220-1

**Vertical PC Board Mount Bulkhead Jack**

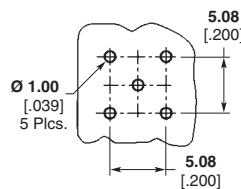
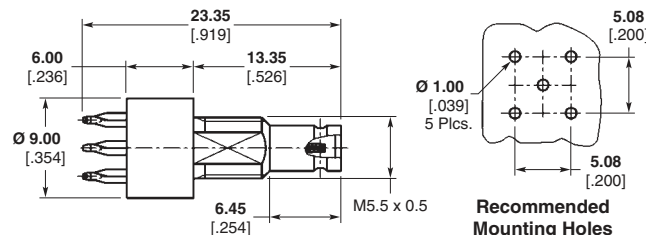

Recommended Mounting Holes

Coupling Type	Part No.
A, C, F	619106-1

**Note:** Part Numbers are RoHS compliant except: ♦ Indicates non-RoHS compliant.

**Series 1.0/2.3, 75 Ohm** (Continued)

**Straight PCB Jacks,  
Multi-Port**

No. of Ports	Coupling Type	Part No.
2	A, C, F	1274714-3
3	A, C, F	1274714-2
4	A, C, F	1274714-1

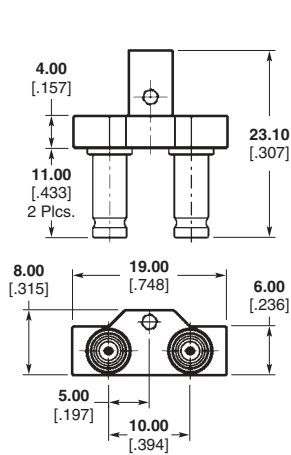

Part Number 1274714-3

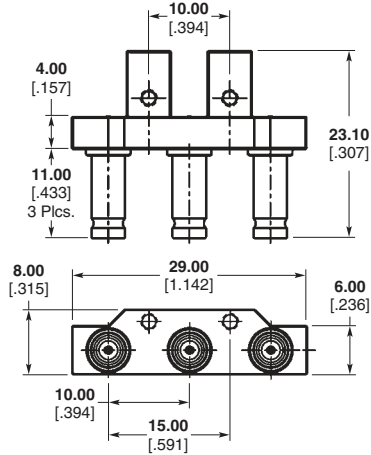

Part Number 1274714-2

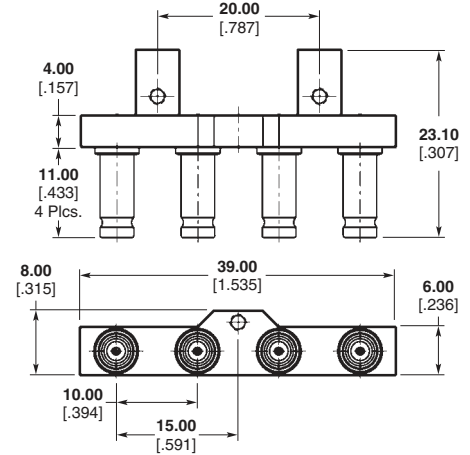

Part Number 1274714-1

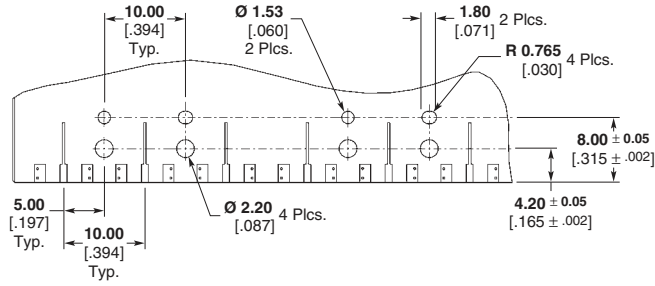

Recommended PC Board Layout  
2 Positions Shown

**Accessories  
for 50 Ohm and 75 Ohm**

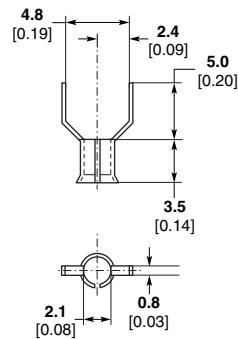

Soldering aid (sleeve) for jack 1393670-8 with solder connection.

Part No.
2-1393562-2

For cable size similar to RG 179 and RG 316

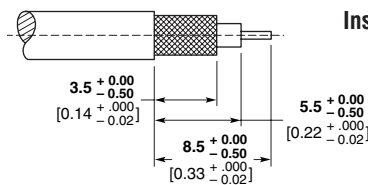

**Installation example:**

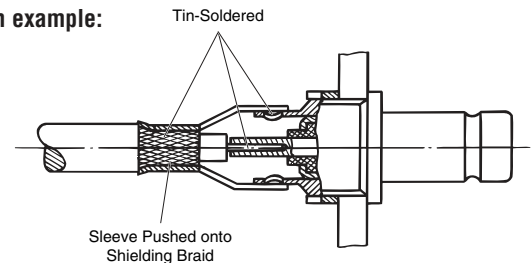

**Note:** For more accessories, see page 147.

**Note:** Part Numbers are RoHS compliant except: ♦ Indicates non-RoHS compliant.

**Series 1.6/5.6 mS (75 Ohm)**



**General**

The Series 1.6/5.6 mS connectors have been modified to incorporate improved technical advantages. Transmission values have been greatly improved while maintaining the proven positive characteristics of the previous genera-

tions. All types of this new "third generation" Series 1.6/5.6 mS connectors are connection-compatible with their predecessor.

Today's PCM technology demands place the Series 1.6/5.6 mS connectors as a most suitable component for transmission of high bit rates.

Connectors are available in straight and angled versions as well as with different mechanisms for screw (type A), snap-on (type B), slide-in (type C), and latching (type F) coupling. All connectors of different coupling mechanisms are compatible with each other.

**Between Series Adapters**

For Series 1.6/5.6 Adapters please see pages 253-262.

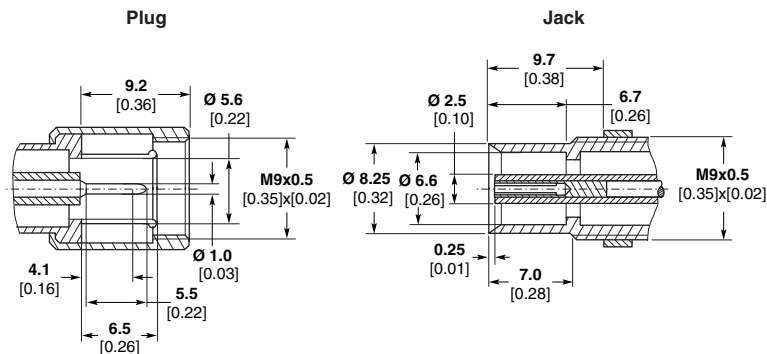

The connectors are designed according to the pin-socket principle. The contacts are partially gold-plated, ensuring long service life and stable contact resistance for a high number of intermateability cycles.

The inner conductor parts are secured so that they cannot be displaced. The insulating parts are made of PEEK (polyetheretherketone) or PC (polycarbonate).

The cable inner conductors are soldered on, while the outer conductors are screwed or crimped on. Also, cable clamp which is independent of the braid clamping secures the connection point against tensile stressing for both methods of connection.

In addition, assembly-friendly connectors with full crimp and IDC (Insulation Displacement Contact) connection are included within

the scope of delivery. The connectors are characterized by high mechanical strength and low space requirement.

Connection possibilities exist for a number of different cables, including highly-flexible cable types (with foam insulation) with low attenuation or small diameter. Terminations and adapters (see also measurement accessories) round out the spectrum.



**Series 1.6/5.6 mS (75 Ohm)** (Continued)

**Technical data**

**Electrical and mechanical characteristics in accordance with CECC 22240**

**Characteristic impedance** — 75 Ω

**Frequency range** — up to 8 GHz

**Reflection factor<sup>1</sup>, referred to —**

flexible cables, straight types —

up to 1 GHz,  $r \leq 0.02$

up to 4 GHz,  $r \leq 0.06$

up to 8 GHz,  $r \leq 0.10$

flexible cables, angled types —

up to 1 GHz,  $r \leq 0.04$

up to 2 GHz,  $r \leq 0.06$

up to 4 GHz,  $r \leq 0.10$

**Insulation resistance** —

initial value,  $\geq 10 \text{ G}\Omega$

after stressing,  $\geq 1 \text{ G}\Omega$

**Screening effectiveness** —

(straight screw connector at 1 GHz)

$\geq 100 \text{ dB}$

**Inner conductor contact**

**resistance** — after stressing  $\leq 8 \text{ m}\Omega$

**Outer conductor continuity** — after

stressing  $\leq 4 \text{ m}\Omega$

**Voltage proof<sup>2</sup>** —

flexible cables (RG 59) —

at sea level, 1.5 kV, 50 Hz

at 20 km altitude, 300 V, 50 Hz

**Working voltage<sup>2</sup>** —

flexible cables (RG 59) —

at sea level, 500 V, 50 Hz

at 20 km altitude, 125 V, 50 Hz

**Service life** — 500 cycles

**Climatic category** — 40/85/21

**Notes:**

<sup>1</sup> Guideline values, depending on cable type and connector style.

<sup>2</sup> Some cable types suitable for use with these connectors have lower characteristic values than specified here.

<sup>3</sup> For applicable cable types see page 151.

**Coupling Types**

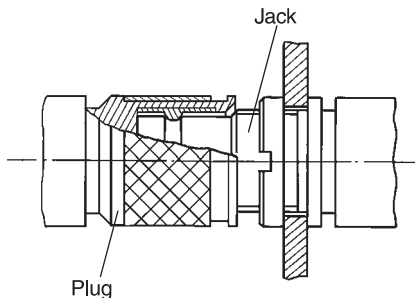
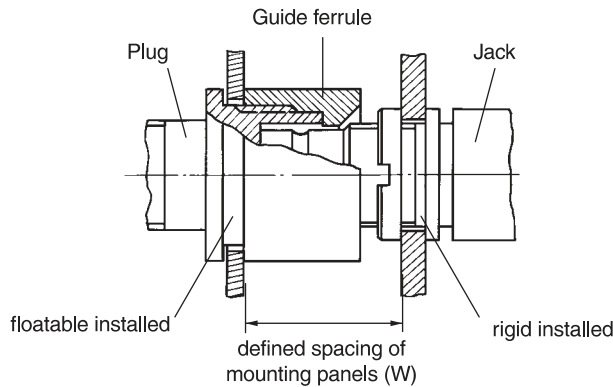
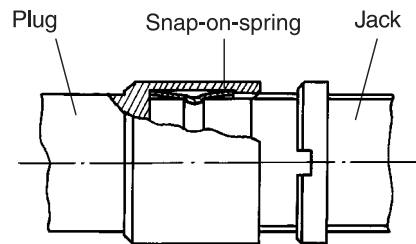
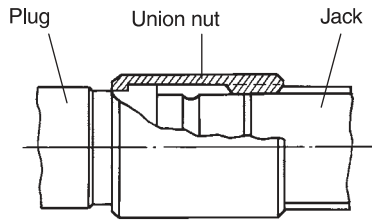

**Type A**

Screw coupling; version with union nut

This type permits the plug and jack to be screwed together manually by means of a union nut secured to the plug manually, thus preventing the coupling from being pulled apart. This is necessary for readily accessible locations, front panel test points and cable connections.

**Type B**

Snap-on coupling (push-pull)

Connectors of this type offer fast make/break. They can be used for test and maintenance applications and also if there is lack of space and connectors with screw coupling cannot be used.

**Type C**

Slide-in coupling; version with centering ferrule

In this type of coupling, the plug features a guide ferrule with a conical entry surface. This ensures that the floatable bulkhead plugs with cable connection make a reliable electrical connection to the rigid installed jack. Examples of this are single and multi-contact connections of slide-in applications. "W" denotes the allowed spacing of the mounting panel for satisfactory contact when the connection is made.

**Type F**

Latching coupling (Quick Lock)

In this version, the cable plugs bear a funnel ferrule with built-in spring which snaps into a groove on the jack, simultaneously locking the connection. The connec-

tion can be easily separated by lightly pulling the outer sleeve of the plug. This type of coupling provides the same amount of axial tensile strength as the screw coupling, but can be used with a higher packing density.

**Series 1.6/5.6 mS (75 Ohm)** (Continued)

**Plugs, Solder/Clamp**

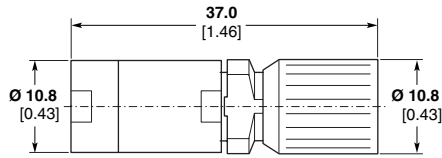

Cable	Coupling Type	Ø Max.	Part No.
2YCCY 0.7/4.4	A	7.8 0.31	1393682-1

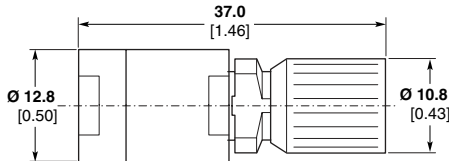

Cable	Coupling Type	Ø Max.	Part No.
2YCCY 1.0/6.5	A	9.8 0.31	1393682-2
2YC(mS)CY 1.0/6.5	A		

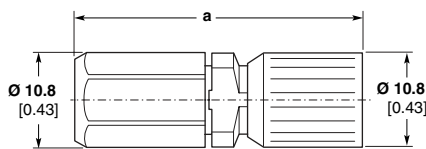

Cable	Coupling Type	Dim. a	Ø Max.	Part No.
2YCY 0.4/2.5	A	30.7 1.21	4.1 0.16	1-1393682-1
2YCCY 0.4/2.5	A	30.7 1.21	4.8 0.19	1-1393682-2
2YC(mS)CY 0.4/2.5	A	30.7 1.21	5.0 0.20	
2YCY 0.7/4.4	A	32.9 1.30	6.1 0.24	1-1393682-3
RG 59	A	32.9 1.30	6.25 0.25	
2YC(mS)CY 0.5/3.0	A	32.9 1.30	6.2 0.24	

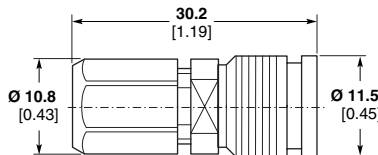

Cable	Coupling Type	Ø Max.	Part No.
02Y(St)CY 0.45/2.0	F	3.6 0.14	1393681-8

**Plugs, Solder/Crimp**

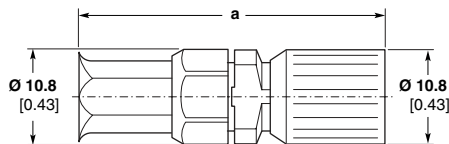

Cable	Coupling Type	Dim. a	Ø Max.	Part No.
RG 179	A	32.5 1.28	2.6 0.105	1393680-2
2YCCY 0.4/2.5	A	32.5 1.28	4.8 0.19	1393680-3
2YC(mS)CY 0.4/2.5	A	35.5 1.40	5.0 0.20	
2YC(mS)CY 0.5/3.0	A	35.5 1.40	6.2 0.24	1393680-4
2YCY 0.7/4.4	A	35.5 1.40	6.1 0.24	1393680-5
02Y(St)CY 0.45/2.0	A	32.5 1.28	3.6 0.14	1393680-9

**Note:** Part Numbers are RoHS compliant except: ♦ Indicates non-RoHS compliant.

**Series 1.6/5.6 mS (75 Ohm)**

**Plugs, Solder/Crimp**  
(Continued)

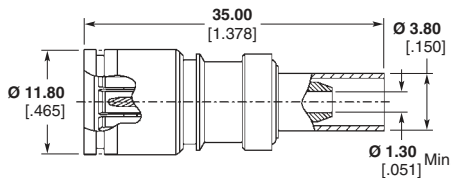
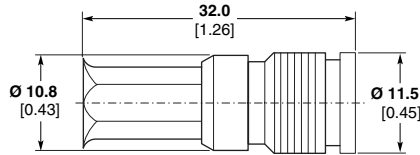
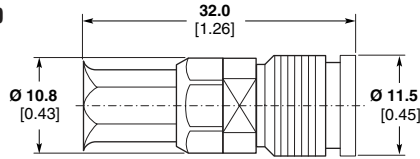

**Right-Angle Plugs, Solder/Crimp**

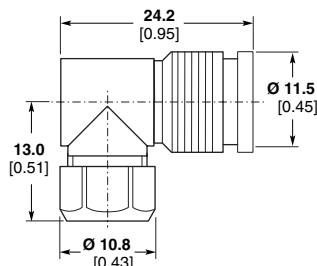
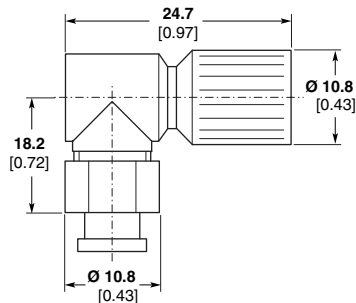
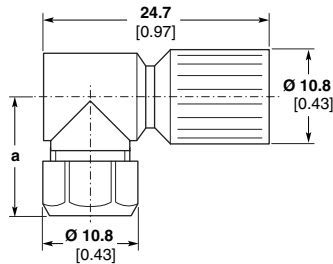

Version with Preassembled Insulation

Cable	Coupling Type	Ø Max.	Part No.
02Y(St)CY 0.45/2.0	F	3.6 0.14	1393672-3

Preassembled Isolation Parts

Cable	Coupling Type	Ø Max.	Part No.
02Y(St)CY 0.45/2.0	F	3.6 0.14	1393672-9

Preassembled Version

Cable	Coupling Type	Ø Max.	Part No.
02YS(St)CHH 0.25/1.2	F	2.9 0.11	1460132-1

Cable	Coupling Type	Dim. a	Ø Max.	Part No.
2YCCY 0.4/2.5	A	13.0 0.51	4.8 0.19	2-1393682-0
2YC(mS)CY 0.4/2.5	A	13.0 0.51	5.0 0.20	
2YCY 0.7/4.4	A	15.8 0.62	6.1 0.24	2-1393682-2
RG 59	A	15.8 0.62	6.25 0.25	
2YC(mS)CY 0.5/3.0	A	15.8 0.62	6.2 0.24	

Cable	Coupling Type	Ø Max.	Part No.
RG 179	A	2.67 0.105	2-1393682-3

Cable	Coupling Type	Ø Max.	Part No.
02Y(St)CY 0.45/2.0	F	3.6 0.14	1-1393681-0

**Note:** Part Numbers are RoHS compliant except: ♦ Indicates non-RoHS compliant.

**Series 1.6/5.6 mS (75 Ohm)** (Continued)

**Right-Angle Plugs,  
Solder/Crimp**

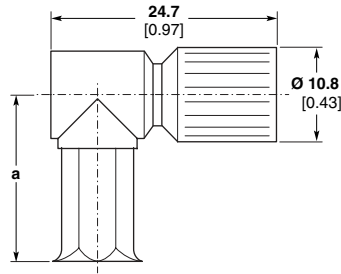

Cable	Coupling Type	Dim. a	Ø Max.	Part No.
02Y12YC(mS)C6Y 0.45/2.0	A	15.0 0.59	4.0 0.16	1-1393680-6
02Y(St)CY 0.45/2.0	A	15.0 0.59	3.6 0.14	1-1393680-8

**Right-Angle Plugs,  
IDC Connection**

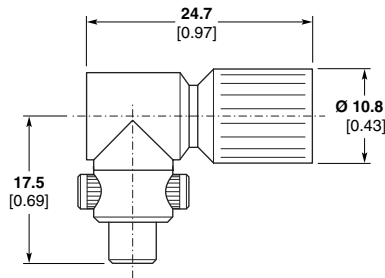

Cable	Coupling Type	Ø Max.	Part No.
02Y(St)CY 0.45/2.0	A	3.6 0.14	1393757-9
2YCY 0.4/2.5	A	4.1 0.16	1393757-8

**Right-Angle Plug,  
Solder/Crimp**

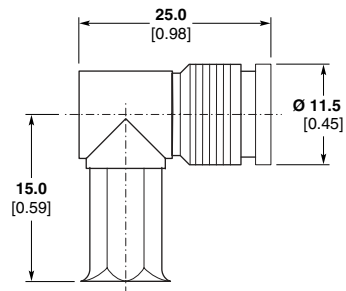

Cable	Coupling Type	Ø Max.	Part No.
02Y(St)CY 0.45/2.0	F	3.6 0.14	1393672-5

**Bulkhead Jacks,  
Solder/Clamp**

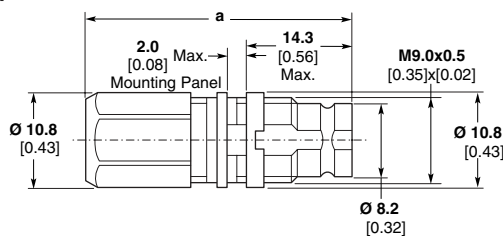

Cable	Coupling Type	Dim. a	Ø Max.	Part No.
2YCY 0.4/2.5	A, B, F	28.1 1.11	4.1 0.16	3-1393682-2
2YCCY 0.4/2.5	A, B, F	28.1 1.11	4.8 0.19	3-1393682-3
2YC(mS)CY 0.4/2.5	A, B, F	28.1 1.11	5.0 0.20	
2YCY 0.7/4.4	A, B, F	30.4 1.20	6.1 0.24	3-1393682-5
RG 59	A, B, F	30.4 1.20	6.25 0.25	
2YC(mS)CY 0.5/3.0	A, B, F	30.4 1.20	6.2 0.24	

**Note:** Part Numbers are RoHS compliant except: ♦ Indicates non-RoHS compliant.

**Series 1.6/5.6 mS (75 Ohm)** (Continued)

**Bulkhead Jacks, Solder/Clamp** (Continued)

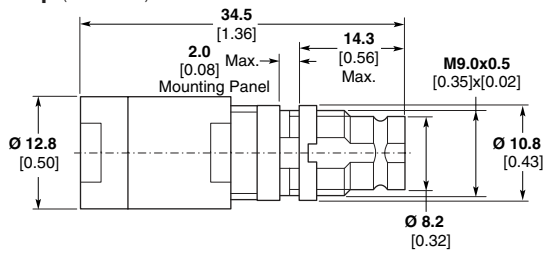

Cable	Coupling Type	Ø Max.	Part No.
2YCCY 1.0/6.5	A, B, F	9.8 0.38	1393682-4
2Y(mS)CY 1.0/6.5	A, B, F	9.8 0.38	

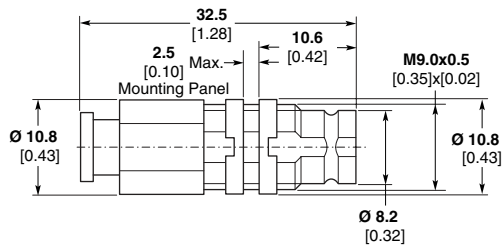

Cable	Coupling Type	Ø Max.	Part No.
RG 179	B, C, F	2.67 0.105	4-1393682-2

**Bulkhead Jacks, Solder**

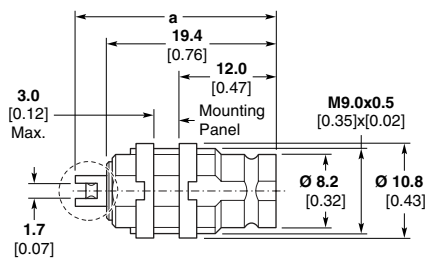

Dim. a	Ø Max.	Part No.
22.3* 0.88	A, B, C, F	1-1393681-1
23.5 0.93	A, B, C, F	1-1393681-9

\*Without soldering tags on outer conductor, dimension a up to inner conductor end.

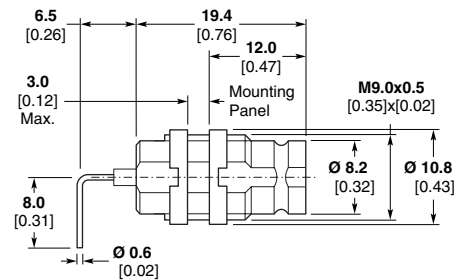

Coupling Type	Part No.
A, B, C, F	1-1393681-3

**Bulkhead Jacks, Solder/Crimp**

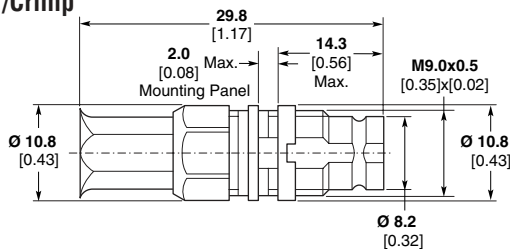

Cable	Coupling Type	Ø Max.	Part No.
RG 179	A, B, F	2.67 0.105	2-1393680-2
02Y12YC(mS)C6Y 0.45/2.0	A, B, F	4.0 0.16	2-1393680-4
06YCC(St)6Y 0.4/1.6	A, B, F	3.3 0.13	2-1393680-5
02Y(St)CY 0.45/2.0	A, B, F	3.6 0.14	1393672-6

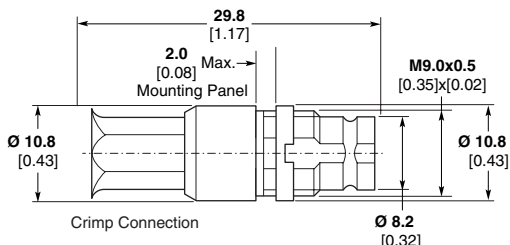

With preassembled insulation parts

Cable	Coupling Type	Ø Max.	Part No.
02Y(St)CY 0.45/2.0	A, B, F	3.6 0.14	1-1393672-4

**Note:** Part Numbers are RoHS compliant except: ♦ Indicates non-RoHS compliant.

**Series 1.6/5.6 mS (75 Ohm)** (Continued)

**Right-Angle Bulkhead Jack, Solder/Clamp**

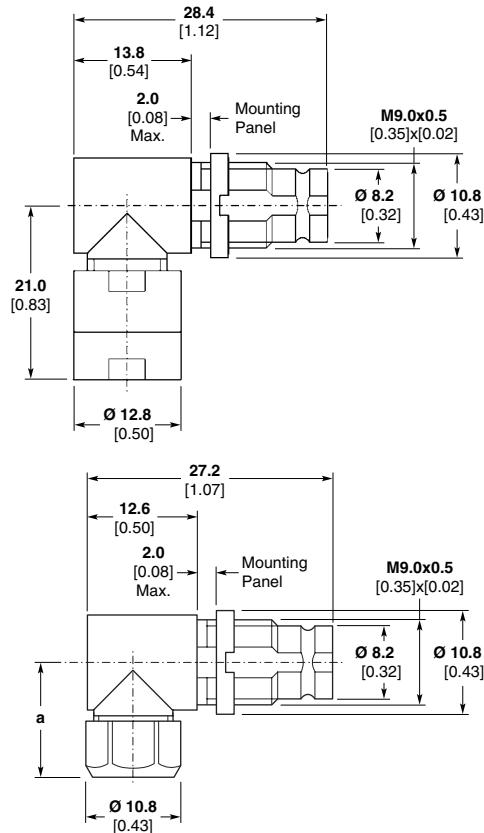

Cable	Coupling Type	Ø Max.	Part No.
2YCCY 1.0/6.5	A, B, F	9.8 0.39	1393682-8
2YC(mS)CY 1.0/6.5	A, B, F	9.8 0.39	

Cable	Coupling Type	Dim. a	Ø Max.	Part No.
02Y(St)CY 0.45/2.0	A, B, F	13.0 0.51	3.6 0.14	4-1393682-9
2YCCY 0.4/2.5	A, B, F	13.0 0.51	4.8 0.19	4-1393682-6
2YC(mS)CY 0.4/2.5	A, B, F	13.0 0.51	5.0 0.20	
2YCY 0.7/4.4	A, B, F	15.8 0.62	6.1 0.24	4-1393682-8
RG 59	A, B, F	15.8 0.62	6.25 0.25	
2YC(mS)CY 0.5/3.0	A, B, F	15.8 0.62	6.2 0.24	

**Right-Angle Bulkhead Jack, Solder/Crimp**

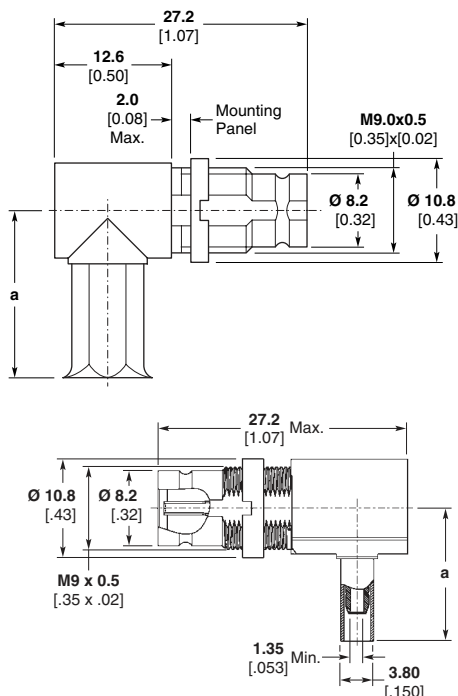

Cable	Coupling Type	Dim. a	Ø Max.	Part No.
RG 179	A, B, F	15.0 0.59	2.67 0.105	3-1393680-0
2YCCY 0.4/2.5	A, B, F	15.0 0.59	4.8 0.19	3-1393680-2
2YC(mS)CY 0.4/2.5	A, B, F	15.0 0.59	5.0 0.20	
02Y12YC(mS)C6Y 0.45/2.0	A, B, F	15.0 0.59	4.0 0.16	3-1393680-5
06YCC(St)6Y 0.4/1.6	A, B, F	15.0 0.59	3.3 0.13	4-1393682-3
02Y(St)CY 0.45/2.0	A, B, F	15.0 0.59	3.6 0.14	3-1393680-7

Cable	Coupling Type	Dim. a	Ø Max.	Part No.
02YS(St)CHH 0.25/1.2	A, B, F	15.0 0.59	2.9 0.11	1460128-1*
02YS(St)CHH 0.25/1.2	A, B, F	15.0 0.59	2.9 0.11	1460169-1**

\* Tray Packaging.  
\*\* Individual Packaging.

**Note:** Part Numbers are RoHS compliant except: ♦ Indicates non-RoHS compliant.

**Series 1.6/5.6 mS (75 Ohm)** (Continued)

**Right-Angle Bulkhead Jack,  
IDC Connection**

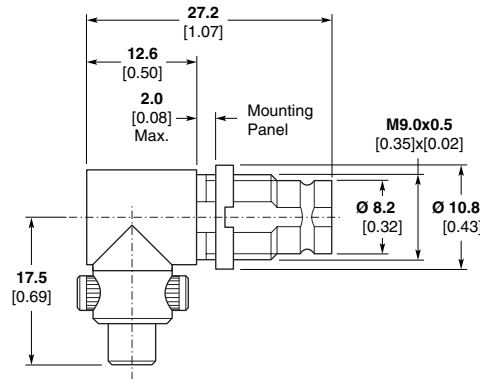

Cable	Coupling Type	Ø Max.	Part No.
02Y(St)CY 0.45/2.0	A, B, F	3.6 0.14	1-1393757-6

**Vertical PC Board  
Mount Jack**

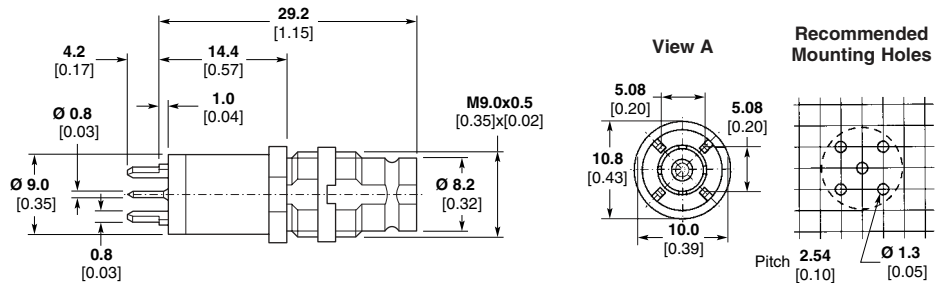

Coupling Type	Part No.
A, B, F	1-1393681-6

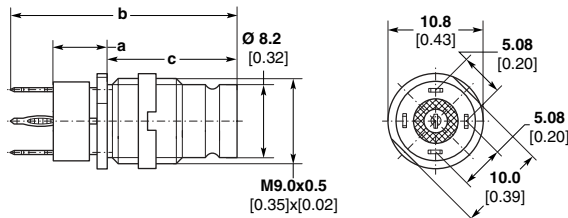

**Inner- and outer conductor, press-fit**

Coupling Type	Dim. a	Dim. b	Dim. c	Part No.
A, B, F	6.0 0.24	27.2 1.07	16.4 0.65	2-1393757-0

**Recommended Mounting Holes**

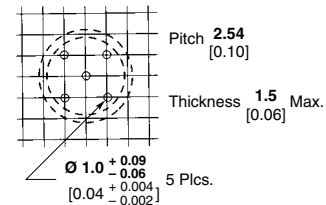

**PC Board Mount  
Bulkhead Jack**

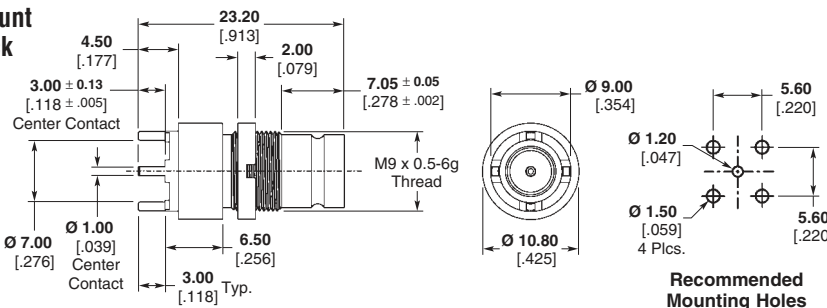

Coupling Type	Part No.
A, B, F	1274513-1

**Note:** Part Numbers are RoHS compliant except: ♦ Indicates non-RoHS compliant.



**Series 1.6/5.6 mS (75 Ohm)** (Continued)

**Right-Angle PC Board Mount Bulkhead Jack**

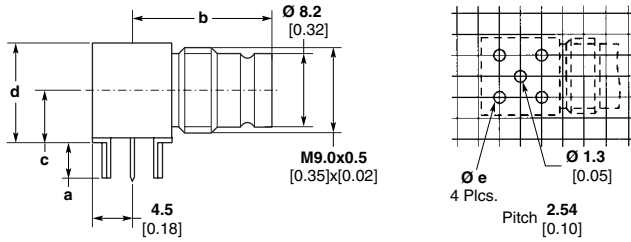

**Recommended Mounting Holes**

Coupling Type	Dim. a	Dim. b	Dim. c	Dim. d	Dim. e	Part No.
A, B, F	4.0 0.16	16.0 0.63	6.0 0.24	10.75 0.42	1.3 0.05	2-1393681-1
A, B, F	3.3 0.13	16.0 0.63	6.0 0.24	10.75 0.42	1.3 0.05	2-1393681-2
A, B, F	3.7 0.15	22.9 0.90	6.45 0.25	11.25 0.44	1.8 0.07	2-1393681-3*

\*With positioning and snap-on system onto PC board

**U-link Plug/Plug**

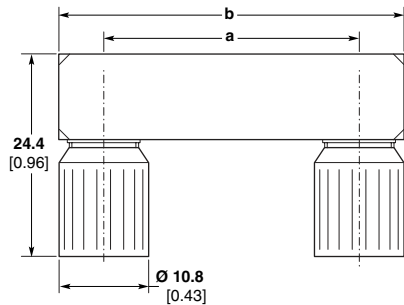

Coupling Type	Dim. a ± 0.1 [0.004]	Dim. b Max.	Part No.
A	15.0 0.59	26.5 1.04	6-1460823-1

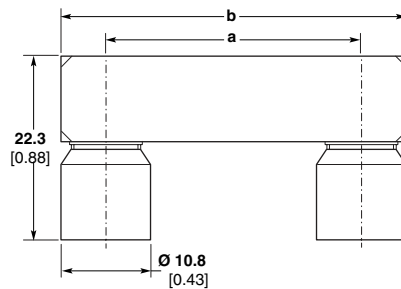

Coupling Type	Dim. a ± 0.1 [0.004]	Dim. b Max.	Part No.
B	15.0 0.59	26.5 1.04	6-1460823-2

**Note:** Part Numbers are RoHS compliant except: ♦ Indicates non-RoHS compliant.

**Series 1.6/5.6 mS (75 Ohm)** (Continued)

**Accessories**

These components are provided when bulkhead jack part numbers are ordered, but can also be ordered separately.

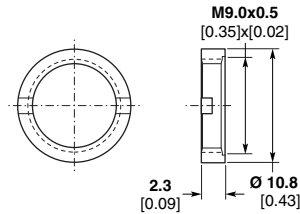

**Threaded ring for installation of bulkhead jacks**

Part No.
1-1393562-0

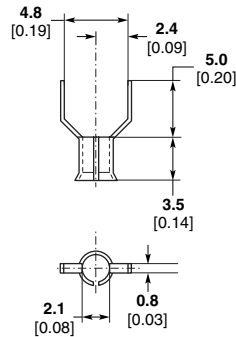

**Soldering aid (sleeve) for jack (1-1393681-9) with solder termination**

Part No.
2-1393562-2

Cable stripping and installation example: see Part number 2-1393562-2 under "Series 1.0/2.3", page 137.

**Measurement Accessories**

**Between Series Adapters (75 Ohm)**

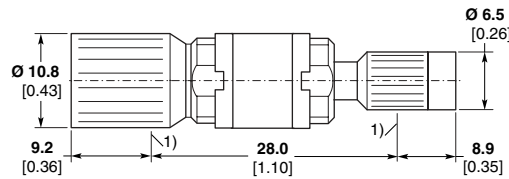

**Plug 1.6/5.6 to Plug 1.0/2.3**

Coupling Type	Part No.
A	6-1460821-1

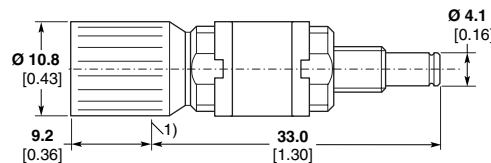

**Plug 1.6/5.6 to Jack 1.0/2.3**

Coupling Type	Part No.
A, F <sup>2</sup>	2-1393670-2 ♦
A, F <sup>2</sup>	6-1460821-2

1) Detent for jack

2 Only jack side

**Note:** Part Numbers are RoHS compliant except: ♦ Indicates non-RoHS compliant.

**Measurement Accessories (Continued)**

**Between Series Adapters (75 Ohm) (Continued)**

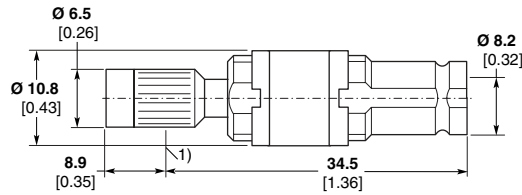

**Plug 1.0/2.3 to Jack 1.6/5.6**

Coupling Type	Part No.
A, B <sup>2</sup> , F <sup>2</sup>	6-1460821-3

<sup>2</sup> Only jack side

1) Detent for jack

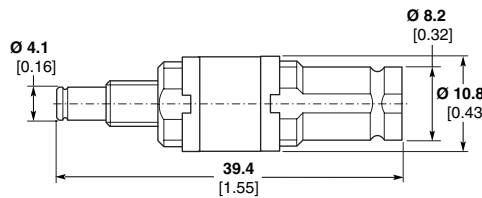

**Jack 1.0/2.3 to Jack 1.6/5.6**

Coupling Type	Part No.
A, B, F	6-1460821-4

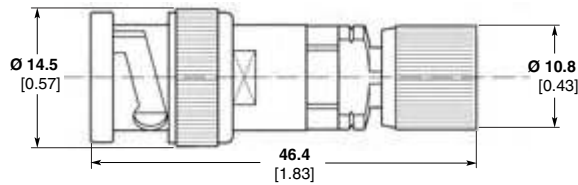

**BNC Plug to Plug 1.6/5.6**

Part No.
7-1393665-4

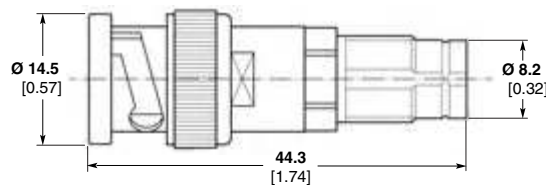

**BNC Plug to Jack 1.6/5.6**

Part No.
7-1393665-6

**Note:** Part Numbers are RoHS compliant except: ♦ Indicates non-RoHS compliant.

**Measurement Accessories** (Continued)

**Between Series Adapters**  
**(75 Ohm)** (Continued)

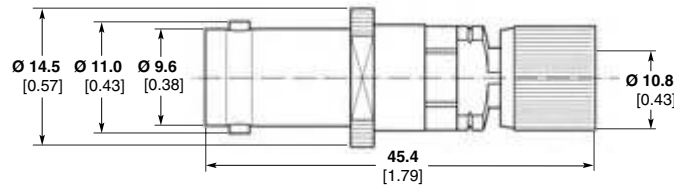

**BNC Jack to Plug 1.6/5.6**

<b>Part No.</b>
7-1393665-7

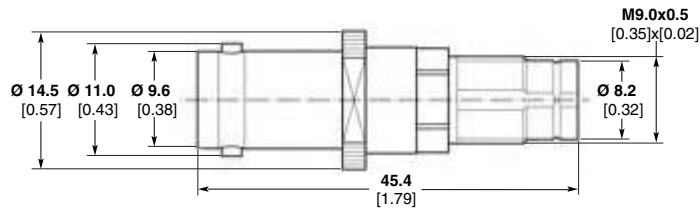

**BNC Jack to Jack 1.6/5.6**

<b>Part No.</b>
7-1393665-5

**Termination (75 Ohm)**

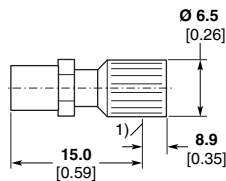

1) Detent for jack

**Standard Termination**

**Plug 1.0/2.3**

Coupling Type	Power W	Part No.
A	0.6	7-1393665-2

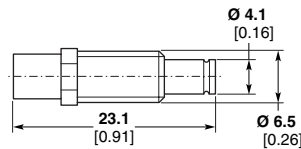

**Jack 1.0/2.3**

Coupling Type	Power W	Part No.
A, F	0.6	7-1393665-3

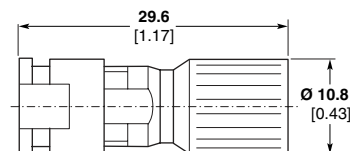

**Plug 1.6/5.6**

Coupling Type	Power W	Part No.
A	1.0	6-1393665-1

**Note:** Part Numbers are RoHS compliant except: ♦ Indicates non-RoHS compliant.

**Measurement Accessories** (Continued)

**In-Series Adapter (75 Ohm)**

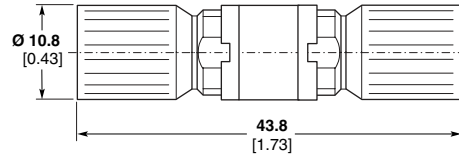

**Adapter 1.6/5.6, Plug/Plug**

Coupling Type	Part No.
A	1393681-6

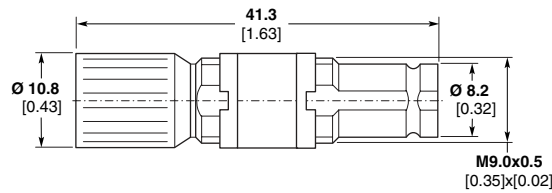

**Adapter 1.6/5.6, Plug/Jack**

Coupling Type	Part No.
A, B*, F*	1-1393681-7

\*Jack side only

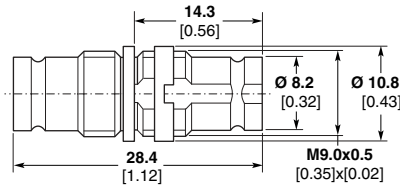

**Adapter 1.6/5.6, Jack/Jack**

Coupling Type	Part No.
A, B, F	1-1393665-1

**Note:**

U-link connectors see "1.6/5.6" section, page 146.

**Note:** Part Numbers are RoHS compliant except: ♦ Indicates non-RoHS compliant.

## Coaxial Cables

List of the coaxial cables that are listed in the various connector series of this section.

Characteristic Impedance (Ω)	Max. Cable Outer Diameter (mm)	Dielectric Diameter (mm)/ Material <sup>1)</sup>	Cable-Type Designation		
			VDE Designation <sup>2)</sup>	US Designation Manufacturer des.	IEC Designation 96-IEC
50	1.9	0.91max/PTFE	5YC5Ye 0.3/0.86	RG 178	50-1-1
50	2.1	0.87/PTFE	—	RG 196	50-1-2
50	2.25	1.71max/PTFE	5YK 0.51/1.68	RG 405	—
50	2.6	1.60max/PTFE	5YC5Ye 0.5/1.5	RG 316	50-2-1
50	2.8	1.60max/PE	2YCY 0.5/1.5	RG 174	—
50	3.0	1.52/PTFE	5YCC5Y 0.5/1.5	RD 316	—
50	3.6	3.01max/PTFE	5YK 0.9/3.0	RG 402	—
50	6.4	5.38max/PTFE	5YK 1.63/5.33	RG 401	—
75	2.67	1.68max/PTFE	5YC6Y 0.3/1.6	RG 179	75-2-1
75	3.0	1.60max/PTFE	—	RD 179	—
75	3.3	1.68max/Cell-FEP	06YCC(St)6Y 0.4/1.6	—	—
75	3.2	2.1max	—	ST 212	—
75	3.6	2.0max/Cell-PE	02Y(St)CY 0.45/2.0	—	—
75	4.0	2.0maxE/Cell-PE	02Y12YC(mS)C6Y 0.45/2.0	—	—
75	4.0	2.54max/PE	2YCY 0.4/2.5	—	—
75	4.8	2.54max/PE	2YCCY 0.4/2.5	—	—
75	5.0	2.54max/PE	2YC(mS)CY 0.4/2.5	—	—
75	6.1	4.25max/PE	2YCY 0.7/4.4	—	—
75	6.2	2.83max/PE	2YC(mS)CY 0.5/3.0	—	—
75	6.25	3.8max/PE	2YCY 0.58/3.7	RG 59	—
75	7.8	4.43max/PE	2YCCY 0.7/4.4	—	—
75	9.8	6.4/PE	2YCCY 1.0/6.5	—	—
75	9.8	6.4/PE	2YC(mS)CY 1.0/6.5	—	—

**1) Material label**

- PTFE Polytetrafluorethylene
- PE Polyethylene
- FEP Perfluorethylene propylene
- PFA Perfluoralkoxy copolymer

**2) Mounting label of the VDE type numbers (from inside to outside)**

**Example:**

**Explanation**

Dielectric and Jacket  
 2Y = PE  
 5Y = PTFE  
 02Y = Cell PE  
 06Y = Cell FEP  
 6Y = FEP

Screen:  
 C = Cu braiding  
 K = Cu tape  
 Intermediate layer:  
 mS = magnetic screen  
 St = static screen

Specifications on inner conductor:  
 vs = silver plated  
 staku = Bare copper-clad steel wire conductor

Jacket color:  
 gn = green  
 gr = grey  
 rt = red  
 ws = white

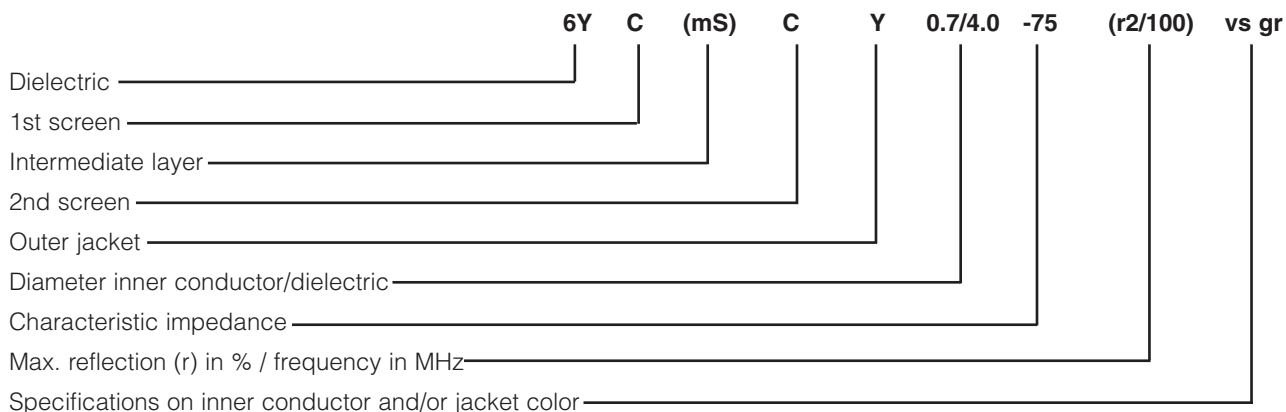

## SMP Microminiature Push-On Coaxial Connectors

### Product Facts

- Intermateable with Corning Gilbert GPO Series Connector
- DESC approved
- Enhanced performance features
- Simplified Assembly

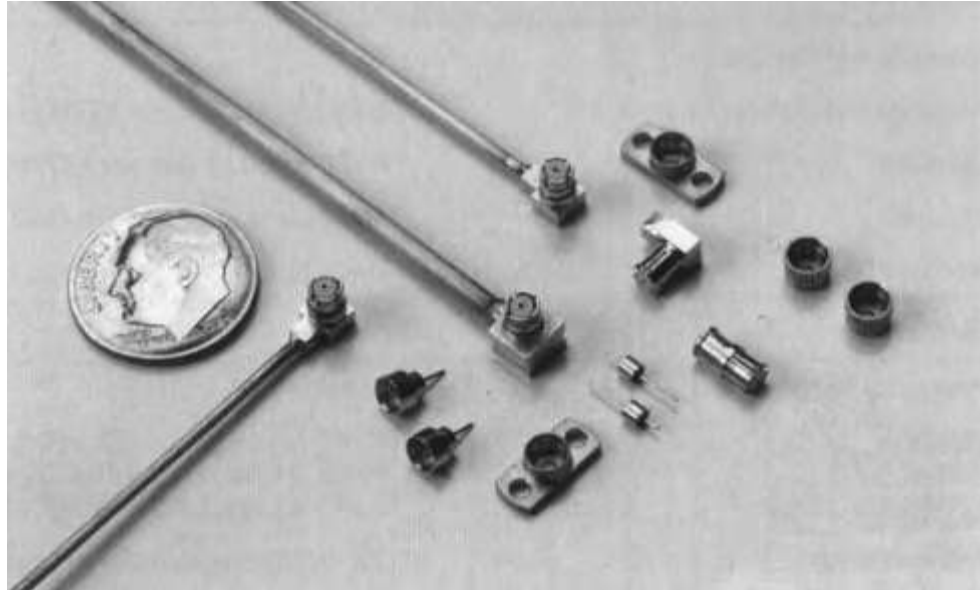

SMP microminiature push-on coaxial connectors provide solutions for today's modular designs with denser packaging requirements. The extremely small size of the SMP offers a versatile solution for high density packaging allowing connector center-to-center spacing of 4.32 [0.17]. The push-on interface facilitates easier assembly and test with a positive snap-in feature to indicate a fully mated connection. The rugged SMP interface can withstand harsh environments of mechanical shock and vibration, typically found in military or aerospace related applications. This SMP connector interface is the standard used by Defense Electronics Supply Center (DESC) to generate the SMP push-on connector series.

SMP connectors can be your design solution for mechanical packaging and frequency response. The SMP interface provides 0.020" of radial misalignment for critical blindmate applications. Mating forces are strictly controlled to ensure reliable connections per mated pair or when simultaneously mating multiple connectors. Cable jacks include an anti-rocking ring to ensure reliable mechanical performance regardless of the operating environment. SMP connectors offer enhanced broadband VSWR performance of

1.15:1 max thru 26GHz and 1.40:1 max thru 40GHz.

Standard design SMP configurations include cable connectors, straight and right-angle, for 0.047 and 0.085 semi-rigid cable, full detent, limited detent and smooth bore mating shrouds that can be bulkhead or flange mounted and glass feedthroughs for coax to circuit launchers. In-series adapters for module to module intermating and between series adapters for integrating or testing systems or components parameters.

### Between Series Adapters

For SMP Between Series Adapters, see pages 253-262.

SMP Shroud and Jack to Jack Adapter Assembly

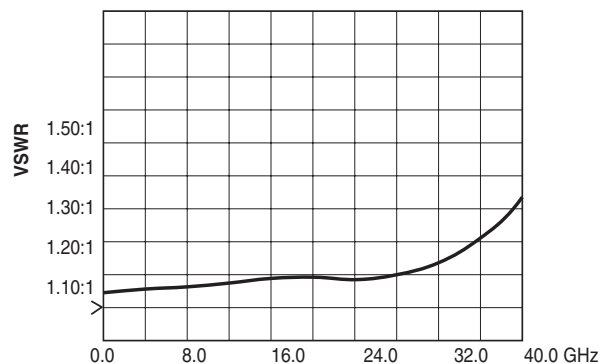
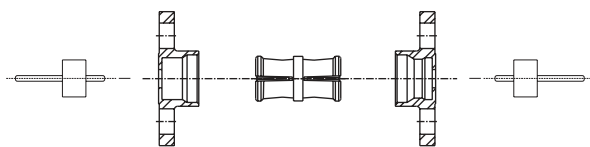

Typical VSWR for SMP Jack to Jack Adapter  
Part Numbers 1056700-1 and 1056721-1

GPO is a trademark of Corning Gilbert, Inc.

**Note:** Part Numbers are RoHS compliant except: ♦ Indicates non-RoHS compliant.

## SMP Microminiature Push-On Coaxial Connectors (Continued)

### Specifications

#### General

Materials and Finishes	
Housings and Center Contacts	Beryllium Copper per ASTM-B-196; gold plate over nickel plate
Dielectric	PTFE Fluorocarbon per ASTM-D-1457
Shrouds	Stainless steel per ASTM-A582 Type 303; passivate per ASTM-A380
Hermetic Seal	Glass bead

#### Electrical

Frequency Range	dc - 40.0 GHz
VSWR	1.10:1 Maximum dc - 23.0 GHz 1.15:1 Maximum 23.0 - 26.0 GHz 1.40:1 Maximum 26.0 - 40.0 GHz
Voltage Rating	335 Vrms maximum at sea level
Insertion Loss	0.10 $f\sqrt{\text{GHz}}$ maximum
Insulation Resistance	5000 megohms minimum
Dielectric Withstanding Voltage	500 volts (VRMS minimum)
RF High Potential	325 volts (VRMS minimum) @ 5 MHz
Impedance	50 ohms nominal
RF Leakage	-80dB to 3 GHz, -65dB from 3 to 26.5 dB minimum
Contact Resistance	Initial center contact 6.0 milliohms maximum Outer contact 2.0 milliohms maximum

#### Mechanical

Durability	100 mating cycles minimum
Radial Misalignment	$\pm 0.020$ minimum
Axial Misalignment	.000/.010
Force to Engage	full detent 15.0 lbs. maximum half detent 10.0 lbs. maximum smooth bore 2.0 lbs. maximum
Force to Disengage	full detent 5.0 lbs. minimum half detent 2.0 lbs. minimum smooth bore 0.5 lbs. minimum
Center Contact Retention	1.5 lbs. minimum axial force

#### Environmental

Operating Temperature	-65°C to +165°C
Vibration	per mil-std-202, method 204, test condition D
Shock	per mil-std-202, method 213, test condition I
Thermal Shock	per mil-std-202, method 107, test condition B
Moisture Resistance	per MIL-STD-202 method 106, except step 7b shall be omitted. Resistance shall be 200 megohms within 5 minutes after removal from humidity.

### Interface Dimensions

#### Jack

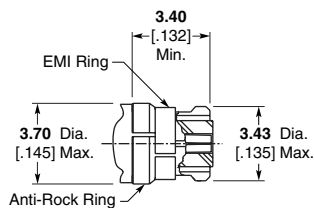

#### Shroud

##### Full Detent

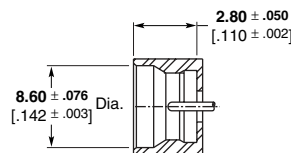

##### Bullet

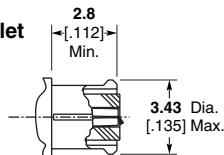

##### Smooth Bore

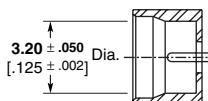

**Note:** The U.S. Government (DESC) has determined that the above specified interface dimensions are interchangeable and intermateable with Corning Gilbert GPO Series RF Connectors.<sup>1</sup>

GPO is a trademark of Corning Gilbert, Inc.

<sup>1</sup> Per DESC drawing numbers 94007 and 94008, series SMP.



**SMP Microminiature Push-On Coaxial Connectors** (Continued)

**Straight Cable Jack, Solder Attachment**

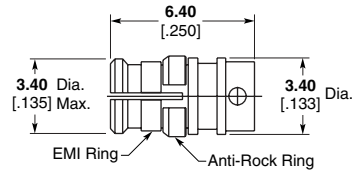

Cable	Part No.
.047 Semi-Rigid	<b>1056526-1</b>
.085 Semi-Rigid (RG 405)	<b>1056527-1</b>

**Right-Angle Cable Jack, Solder Attachment**

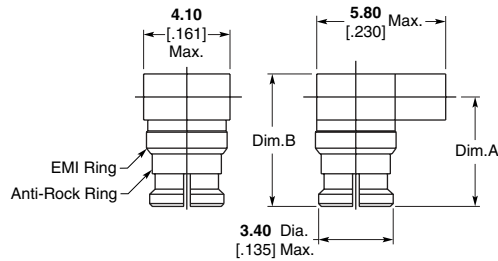

Cable	Dim. A	Dim. B	Part No.
.047 Semi-Rigid	<b>4.8</b> .190	<b>5.8</b> .230	<b>1056553-1</b>
.085 Semi-Rigid (RG 405)	<b>5.3</b> .209	<b>6.7</b> .265	<b>1056554-1</b>

**Jack to Jack Adapter (Bullet)**

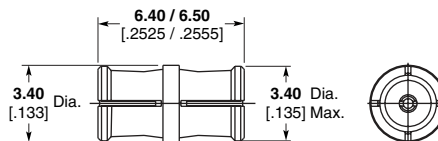

Part No.
<b>1056700-1</b>

**Note:** Part Numbers are RoHS compliant except: ♦ Indicates non-RoHS compliant.

**SMP Microminiature Push-On Coaxial Connectors** (Continued)

**Shroud — Threaded**

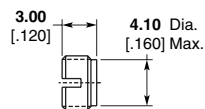

Description	Part No.
Full Detent	1056745-1
Limited Detent	1056743-1
Smooth Bore	1056744-1

**Shroud — 2 Hole Flange Surface Mount**

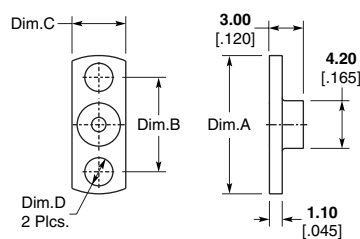

Description	Dim. A	Dim. B	Dim. C	Dim. D	Part No.
Full Detent	12.2 .480	8.3 .328	4.7 .187	2.5 .098	1056721-1
	15.8 .625	12.2 .481	5.7 .223	2.6 .102	1056722-1
	10.2 .400	7.2 .282	4.2 .165	1.9 .073	1056724-1
Limited Detent	12.2 .480	8.3 .328	4.7 .187	2.5 .098	1056729-1
	10.2 .400	7.2 .282	4.2 .165	1.9 .073	1056731-1

**Shroud — Press Fit**

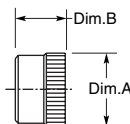

Description	Dim. A	Dim. B	Part No.
Limited Detent	3.9 .154	2.0 .080	1056736-1

**Note:** Part Numbers are RoHS compliant except: ♦ Indicates non-RoHS compliant.

**SMP Microminiature Push-On Coaxial Connectors** (Continued)

**Shroud — Solder-In  
Hermetic**

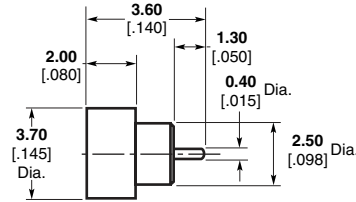

Description	Part No.
Full Detent	1056750-1
Limited Detent	1056751-1
Smooth Bore	1056752-1

**Glass Bead Assembly**

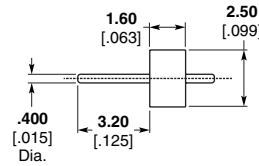

Part No.
1056728-1

**Plug, Straight, Full Detent**

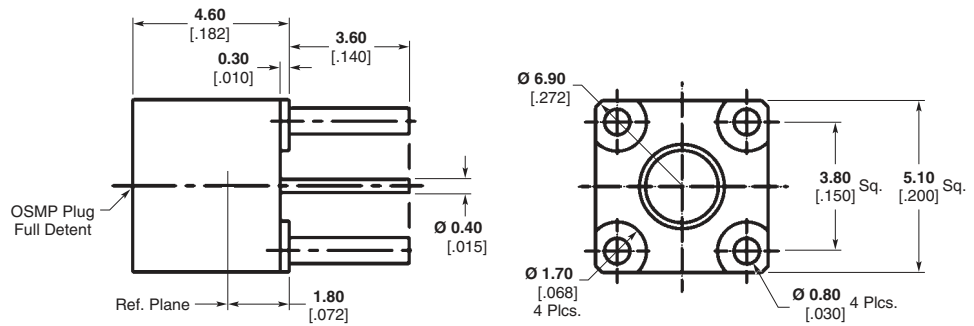

**Plug, Right-Angle, Limited  
Detent**

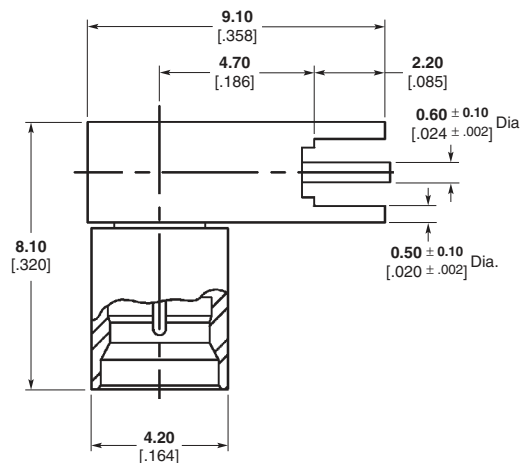

M/A-COM Model Number	Part No.
2965-5006-62	1061692-1

**Note:** Part Numbers are RoHS compliant except: ♦ Indicates non-RoHS compliant.

## OSP Miniature Modular Blind Mate Connectors

### Product Facts

- Interface designed for multiple interconnects
- For high performance microwave system requirements
- Module to module, module to motherboard, fixed and float mount
- Bulkhead or panel mount
- For flexible and semi-rigid cable



OSP miniature connectors for semi-rigid cable meet high performance requirements for microwave multiple interconnects. Standard units are available in bulkhead or panel mount designs for either direct solder or solderless compression crimp attachment. Complete tooling for both versions is located in the Tooling Section of this catalog.

Jack connectors are available in either float or rigid mount. Rigid mount units will function to specifications up to  $\pm .10$  [.004] radial misalignment with the mating plug connector. Applications requiring greater than  $\pm .10$  [.004] radial misalignment can use either the float design or floating connector plates with guide pins.

The solderless compression crimp attachment meets

high performance requirements for microwave system applications. The cable attachment is permanent and highly reliable.

Ease of assembly permits users unskilled in soldering techniques to rapidly produce cable assemblies with consistently excellent mechanical and electrical performance.

**OSP Miniature Modular Blind Mate Connectors (Continued)**

The specifications given refer specifically to mated pair of Part Numbers 1059410-1 and 1059402-1 (RG 402) and 1059412-1 and 1059404-1 (RG 405). Specifications on other connectors are available on request.

The general electrical, mechanical and environmental specifications in the following table are recommended for procurement documents or drawings.

**Engineering Data**

Impedance —	50 ohms
Frequency —	dc to 22.0 GHz
Temperature Rating —	-65° to 125° C

**Electrical**

	<b>RG 402 (.141) Semi-Rigid</b>	<b>RG 405 (.085) Semi-Rigid</b>
VSWR —		
dc - 18.0 GHz	1.02 + .005f (GHz)	1.05 + .005f (GHz)
18.0 - 22.0 GHz	1.02 + .008f (GHz)	1.05 + .009f (GHz)
RF Transmission Loss —	.03 x $\sqrt{f}$ (GHz)	.03 x $\sqrt{f}$ (GHz)
Insulation Resistance —	5,000 megohms min.	5,000 megohms min.
Contact Resistance —		
Center Contact	2.0 milliohms max.	2.0 milliohms max.
Outer Contact	2.0 milliohms max.	2.0 milliohms max.
Outer Contact to Cable	0.5 milliohms max.	0.5 milliohms max.
Dielectric Withstanding Voltage —	1500 volts RMS	1000 volts RMS
Corona Extinction Voltage at 70,000 Ft.—	375 volts min.	335 volts min.
RF High Potential at 5 MHz —	1,000 volts RMS	670 volts RMS
RF Leakage Interface Only —	-(90-fGHz) dB min. (fully mated)	-(90-fGHz) dB min. (fully mated)
Power Handling —	300W at 3 GHz (sea level) and room temperature	

**Environmental**

Corrosion —	Method 101, Condition B, MIL-STD-202
Vibration —	Method 204, Condition D, 20G's, MIL-STD-202
Shock —	Method 213, Condition I, 100G's, MIL-STD-202
Temperature Cycling —	Method 107, Condition B, MIL-STD-202
Moisture Resistance —	Method 106, MIL-STD-202

**Material**

Housing —	Corrosion resistant steel Type 303 (stainless) per ASTM A484 and A582
Center Contact —	Beryllium copper per ASTM-B-196
Dielectric —	TFE fluorocarbon per ASTM-D-1457
Gasket (O'Ring) —	MIL-P-25732

**Mechanical**

Force to Engage —	3 pounds max.
Force to Disengage —	1.5 pounds max.
Center Contact Retention —	6 pounds min.
Durability —	5,000 Cycles
Radial Misalignment —	
Rigid Mount	±.10 [±.004]
Float Mount	±.51 [±.020]

**Mating Characteristics**

Jack Connector —		
Center Contact Socket	Oversize test Pin —	.945 + .003 [.0372 + .0001] dia.
	Test Pin Finish —	16 micro inch
	Insertion Depth —	.76/1.14 [.030/.045]
	Number of Insertions —	3
Insertion Force	Test Pin —	.940 + .003 [.0370 + .0001] dia.
	Test Pin Finish —	16 micro inch
	Insertion Depth —	1.27/1.91 [.050/.075]
	Insertion Force —	3 pounds max.
Withdrawal Force	Test Pin —	.90 + .003 [.0355 - .0001] dia.
	Test Pin Finish —	16 micro inch
	Insertion Depth —	1.27/1.91 [.050/.075]
	Withdrawal —	1 ounce min.

**Finish**

Center Contact —	Gold plate per MIL-G-45204, Type II, Class 1 over copper plate per MIL-C-14550
Housing —	Gold plate per MIL-G-45204, Typ II, Class 0 over nickel plate per QQ-N-290, Class 2 or passivate per ASTM-A380

**All dimensions shown are nominal.  
Contact the factory for specific tolerances.**

**OSP Miniature Modular Blind Mate Connectors (Continued)  
Interface Mating Dimensions**

The connector interface, specifically designed for multiple interconnects, maintains reliable performance over the typical mechanical tolerance required in cost effective packaging.

The interface test data shows excellent performance is maintained with mating gaps up to 0.38 [.015].

Meets MIL-STD-348 Figure 321. Intermateable to BMA Connectors.

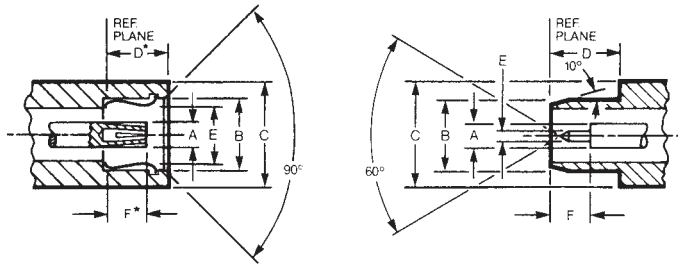

**Jack**

**Plug**

Letter	Dimensions
A	1.78 .070 Nom.
B	5.72 .225 Min.
C	7.62 .300 Ref.
D	5.00 .197 Nom.*
E	5.08 .200 Max.
F	3.23 .127 Max.*

Letter	Dimensions
A	1.78 .070 Nom.
B	5.33 .210 Nom.
C	7.62 .300 Ref.
D	5.05 .199 Min.
E	0.91 .036 Nom.
F	3.25 .128 Min.

\*With spring bottomed

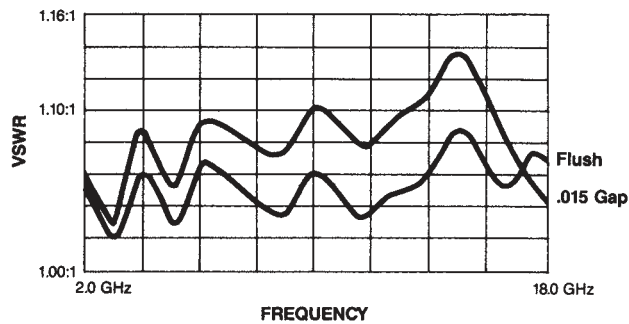

**OSP Miniature Modular Blind Mate Connectors (Continued)**  
**For Semi-Rigid Cable, Direct Solder Attachment**

**Bulkhead Feedthrough  
Cable Plug  
Rear Mount**

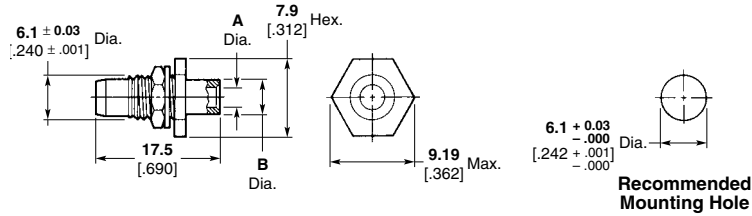

Cable	Plating	Dimensions		Part No.
		A	B	
RG 402/U 3.58 .141	Gold	3.7 .144	4.6 .180	1059402-1
RG 405/U 2.16 .085	Gold	2.3 .089	3.0 .120	1059404-1

**Bulkhead Feedthrough  
Cable Jack Rigid  
Rear Mount**

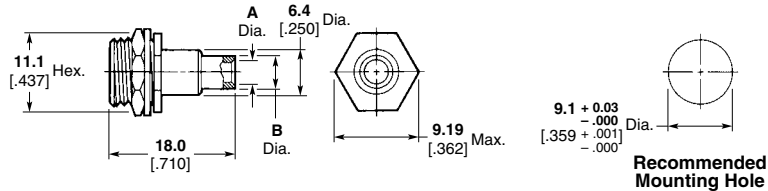

Cable	Plating	Dimensions		Part No.
		A	B	
RG 402/U 3.58 .141	Gold	3.7 .144	4.6 .180	1059410-1
RG 405/U 2.16 .085	Gold	2.3 .089	3.0 .120	1059412-1

**Flange Mount Cable Jack  
Floating Rear Mount**

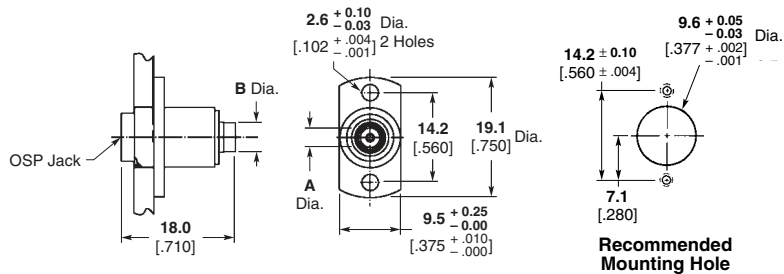

Cable	Dimensions		Part No.
	A	B	
RG 402/U 3.58 .141	3.7 .144	4.6 .180	1059453-1
RG 405/U 2.16 .085	2.3 .089	3.0 .120	1059456-1

Finish: Inner housing that is soldered to cable is gold plated. Outer housing is passivated stainless steel.  
When using semi-rigid cable, it is recommended that a service loop be used to facilitate the float features of the connector.

**Note:** Part Numbers are RoHS compliant except: ♦ Indicates non-RoHS compliant.

**OSP Miniature Modular Blind Mate Connectors (Continued)**  
**For Semi-Rigid Cable, Direct Solder Attachment (Continued)**

**Low Profile — Bulkhead Feedthrough Cable Jack — Floating Rear Mount**

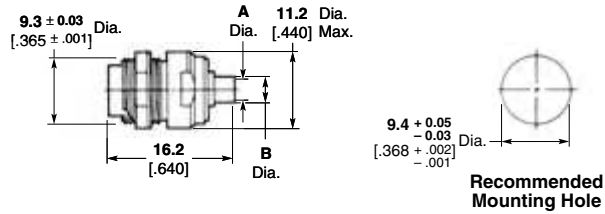

Cable	Plating	Dimensions		Part No.
		A	B	
RG 402/U 3.58 .141	Gold	3.7 .144	4.6 .180	1059505-1
RG 405/U 2.16 .085	Gold	2.3 .089	3.0 .120	1059506-1

When using semi-rigid cable, it is recommended that a service loop be used to facilitate the float features of the connector.

**Low Profile — Panel Feedthrough Cable Jack — Floating Rear Mount**

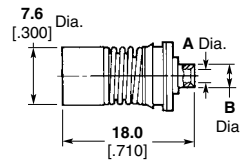

Cable	Plating	Dimensions		Part No.
		A	B	
RG 402/U 3.58 .141	Gold	3.7 .144	4.6 .180	1059465-1
RG 405/U 2.16 .085	Gold	2.3 .089	3.0 .120	1059467-1

Recommended removal tool part number 1059774-1 is described in the Tooling Section of this catalog.  
 When using semi-rigid cable, it is recommended that a service loop be used to facilitate the float features of the connector.

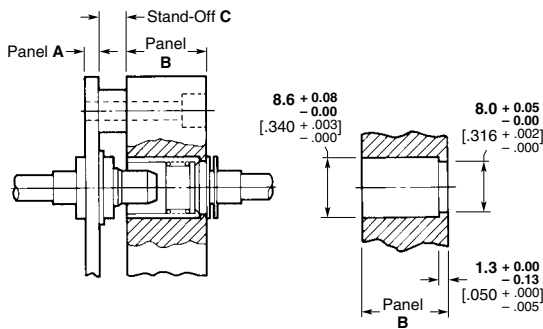

**Recommended Mounting Detail**

Panel A ±.003	Panel B ±.003	Stand-Off Panel C +.050/-0.000
2.3 .090	9.5 .375	7.2 .285
2.3 .090	11.1 .438	5.6 .222
2.3 .090	12.7 .500	4.1 .160
3.2 .125	9.5 .375	6.4 .250
3.2 .125	11.1 .438	4.7 .187
3.2 .125	12.7 .500	3.2 .125

**Note:** Part Numbers are RoHS compliant except: ♦ Indicates non-RoHS compliant.



**OSP Miniature Modular Blind Mate Connectors (Continued)**  
**For Semi-Rigid Cable, Solderless Compression Crimp Attachment**

**Bulkhead Feedthrough Cable Plug Fixed Rear Mount**

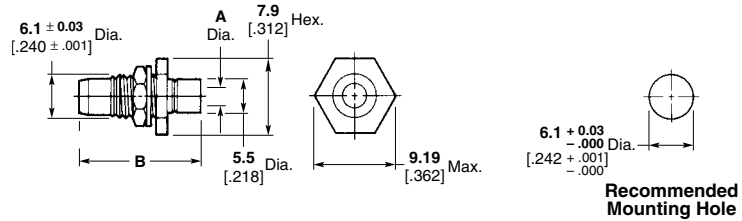

Cable	Plating	Dim. A	Dim. B		Part No.
			Before Crimping	After Crimping	
RG 405/U 2.16 .085	Passivated Stainless Steel	2.2 .088	19.8 .782	17.2 .677	1059399-1

Outline drawing shows after crimp dimensions.

**Bulkhead Feedthrough Cable Jack Fixed Rear Mount**

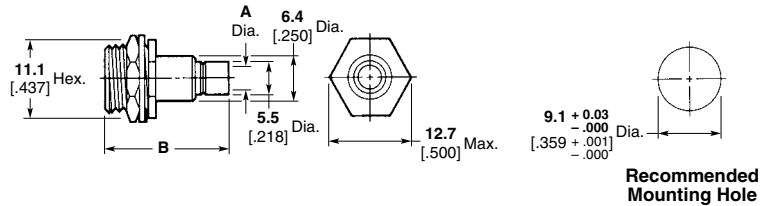

Cable	Plating	Dim. A	Dim. B		Part No.
			Before Crimping	After Crimping	
RG 402/U 3.58 .141	Passivated Stainless Steel	3.6 .143	21.1 .830	18.2 .715	1059408-1

Outline drawing shows after crimp dimensions.

**Flange Mount Cable Jack Floating Rear Mount**

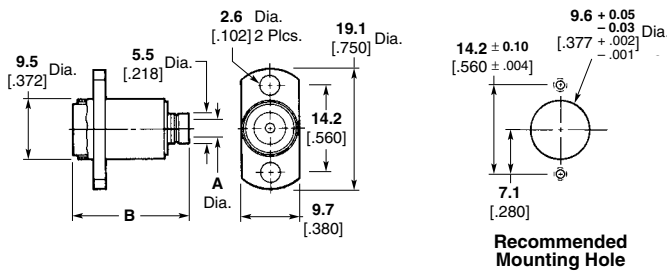

Cable	Plating	Dim. A	Dim. B		Part No.
			Before Crimping	After Crimping	
RG 402/U 3.58 .141	Passivated Stainless Steel	3.6 .143	22.6 .891	19.8 .780	1059451-1
RG 405/U 2.16 .085	Passivated Stainless Steel	2.2 .088	22.6 .891	19.8 .780	1059452-1

Outline drawing shows after crimp dimensions.

When using semi-rigid cable, it is recommended that a service loop be used to facilitate the float features of the connector.

**Note:** Part Numbers are RoHS compliant except: ♦ Indicates non-RoHS compliant.

**OSP Miniature Modular Blind Mate Connectors (Continued)**  
**For Flexible Cable, Crimp Attachment**

**Bulkhead Feedthrough Cable Plug Rear Mount**

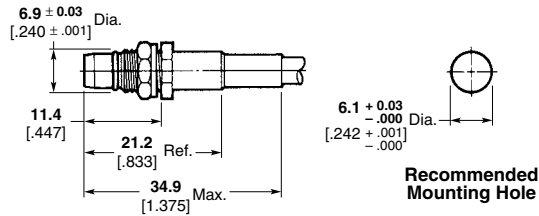

Cable	Plating	Part No.
RG 174/U, 179, 187, 188, 316	Passivated Stainless Steel	1059523-1

**Bulkhead Feedthrough Cable Jack Rigid Rear Mount**

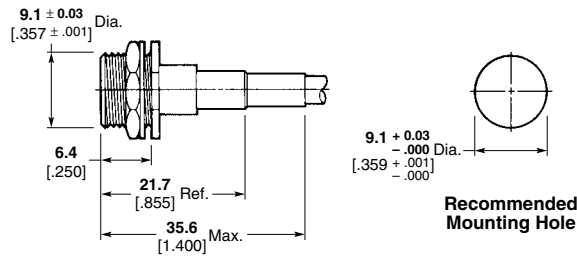

Cable	Plating	Part No.
RG 55/U, 142, 223, 400	Passivated Stainless Steel	1059525-1

**Flange Mount Cable Jack Floating Rear Mount**

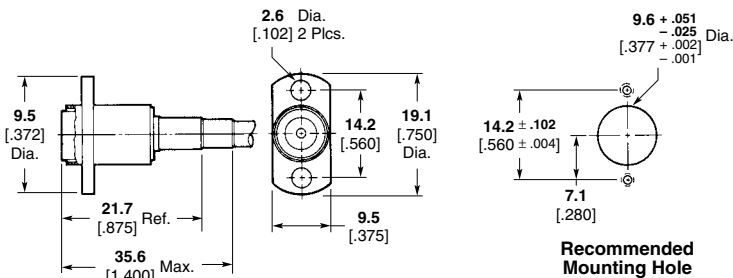

Cable	Plating	Part No.
RG 55/U, 142, 223, 400	Passivated Stainless Steel	1059540-1
RG 174/U, 179, 187, 188, 316	Passivated Stainless Steel	1059541-1
RG 178, Double Braid	Passivated Stainless Steel	1058572-1

**Low Profile — Panel Feedthrough Cable Jack — Rear Mount**

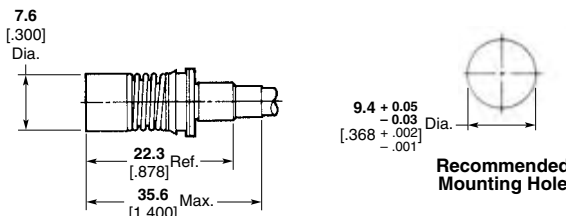

Cable	Plating	Part No.
RG 174/U, 179, 187, 188, 316	Passivated Stainless Steel	1059551-1

**Note:** Part Numbers are RoHS compliant except: ♦ Indicates non-RoHS compliant.

Refer to Recommended Mounting Hole Detail for Semi-Rigid Cable Low Profile Feedthrough Cable Jack. Recommended removal tool part number 1059774-1 as described in the Tooling Section of this catalog.

**OSP Miniature Modular Blind Mate Connectors (Continued)**  
**Panel Mount**

**Straight Terminal**  
**2-Hole Flange Mount Plug**  
**Receptacle**

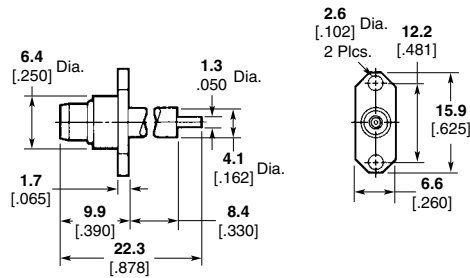

Plating	Part No.
Passivated Stainless Steel	1059566-1

**2-Hole Flange Mount Jack**  
**Receptacle**

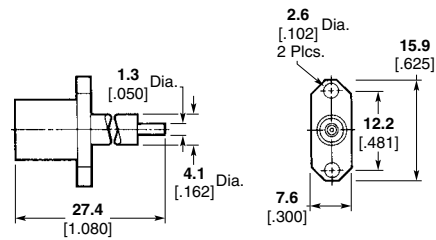

Plating	Part No.
Passivated Stainless Steel	1059596-1

**4-Hole Flange Mount Plug**  
**Receptacle**

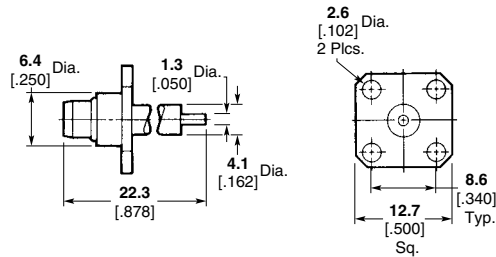

Plating	Part No.
Passivated Stainless Steel	1059563-1

**4-Hole Flange Mount Jack**  
**Receptacle**

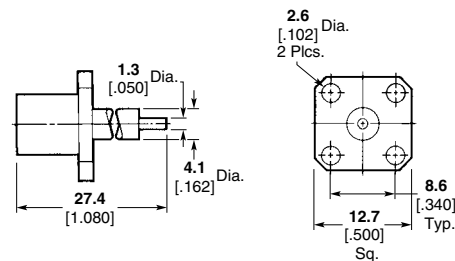

Plating	Part No.
Passivated Stainless Steel	1059594-1

**Note:** Part Numbers are RoHS compliant except: ♦ Indicates non-RoHS compliant.

**OSP Miniature Modular Blind Mate Connectors (Continued)**  
**Panel Mount (Continued)**

**Straight Terminal**  
**Threaded Installation —**  
**Panel Feedthrough Plug**  
**Receptacle**

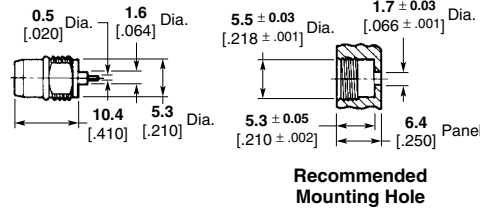

Plating	Part No.
Passivated Stainless Steel	1059617-1

**Recommended  
Mounting Hole**

**Threaded Installation —**  
**Panel Feedthrough Jack**  
**Receptacle**

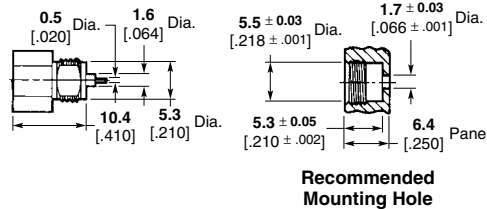

Plating	Part No.
Passivated Stainless Steel	1059657-1

**Recommended  
Mounting Hole**

**Press Fit Installation —**  
**Panel Feedthrough Plug**  
**Receptacle**

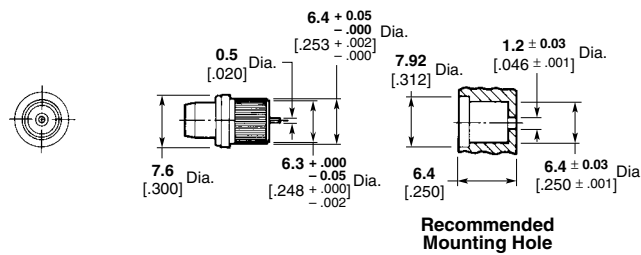

Plating	Part No.
Passivated Stainless Steel	1059651-1

**Recommended  
Mounting Hole**

**Press Fit Installation —**  
**Panel Feedthrough Jack**  
**Receptacle**

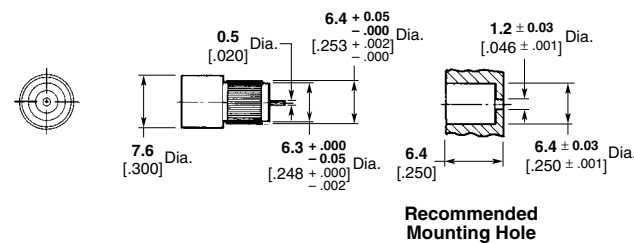

Plating	Part No.
Passivated Stainless Steel	1059654-1

**Recommended  
Mounting Hole**

**Note:** Part Numbers are RoHS compliant except: ♦ Indicates non-RoHS compliant.

**OSP Miniature Modular Blind Mate Connectors (Continued)**  
**Printed Circuit Board Mount**

**Straight Plug Receptacle —  
Captured Contact**

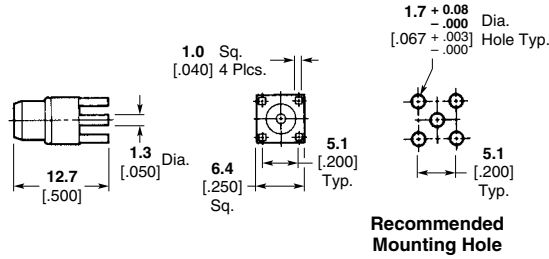

Plating	Part No.
Gold	1059684-1

**Straight Jack Receptacle —  
Captured Contact**

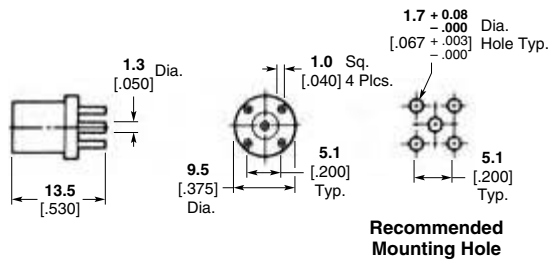

Plating	Part No.
Gold	1059681-1

**Right-Angle Plug Receptacle —  
Captured Contact**

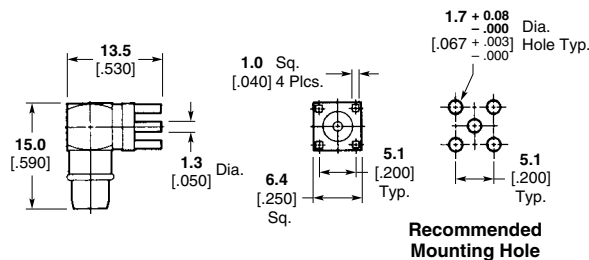

Plating	Part No.
Gold	1059691-1

**Surface Mount Vertical Plug with  
Small Leg**

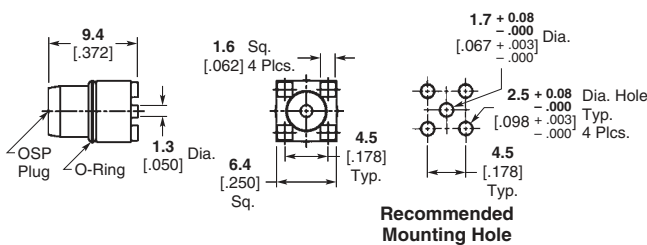

Plating	Part No.
Gold	1253111-1

**Note:** Part Numbers are RoHS compliant except: ♦ Indicates non-RoHS compliant.

**OSP Miniature Modular Blind Mate Connectors (Continued)**  
**Hermetically Sealed**

**Metal-To-Metal**  
**Rigid Gasket Seal —**  
**Panel Feedthrough**  
**Plug Receptacle**

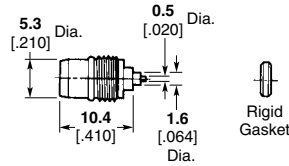

VSWR (GHz)	RF Leakage (dB)	Plating	Part No.
1.04 + .009f	-(90-fGHz)	Passivated stainless steel	<b>6059632-1</b>

Installation Thermal Limit: 250°C.  
 Recommended Mounting Hole Detail A follows, pg 168.

**Rigid Gasket Seal —**  
**Panel Feedthrough**  
**Jack Receptacle**

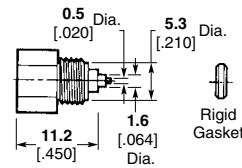

VSWR (GHz)	RF Leakage (dB)	Plating	Part No.
1.04 + .009f	-(90-fGHz)	Passivated stainless steel	<b>6059665-1</b>

Installation Thermal Limit: 250°C.  
 Recommended Mounting Hole Detail A follows, pg 168.

**Field Replaceable**  
**Solder and Braze-In**  
**Panel Feedthrough Plug**  
**Receptacle**

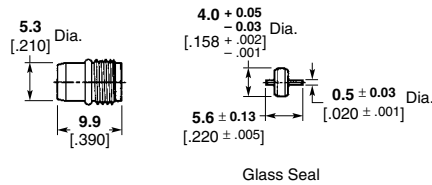

VSWR (GHz)	RF Leakage (dB)	Plating	Part No.
1.06 + .01f	-(90-fGHz)	Passivated stainless steel	<b>1059637-1</b>

Recommended Mounting Detail B or E follows, pg 168.

**Note:** Part Numbers are RoHS compliant except: ♦ Indicates non-RoHS compliant.

**OSP Miniature Modular Blind Mate Connectors (Continued)**  
**Hermetically Sealed (Continued)**

**Field Replaceable Solder and Braze-In**

(Continued)

**Panel Feedthrough Jack Receptacle**

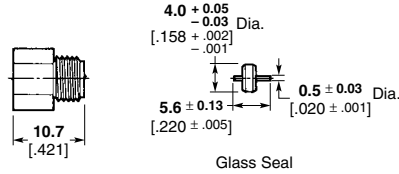

VSWR (GHz)	RF Leakage (dB)	Plating	Part No.
1.06 + .01f	-(90-fGHz)	Passivated stainless steel	<b>1059671-1</b>

Recommended Mounting Detail B or E follows at bottom of this page.

**2-Hole Flange Mount Plug Receptacle With EMI/RFI Gasket — 0.5 [0.018] Dia. Contact**

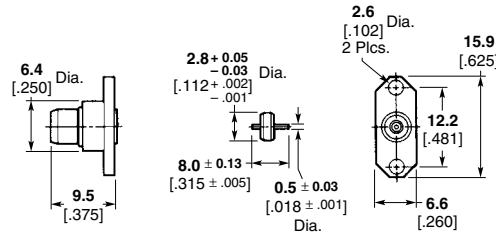

VSWR (GHz)	RF Leakage (dB)	Plating	Part No.
1.06 + .01f	-(90-fGHz)	Passivated stainless steel	<b>1059572-1</b>

Recommended Mounting Detail D follows at bottom of this page.

**Recommended Mounting Hole Detail**

**Detail A\***

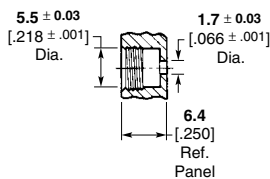

**Detail B\* (6.35 [0.250] Panel Thickness)**

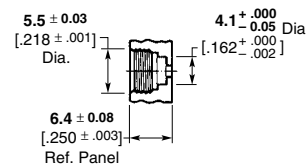

**Detail C\***

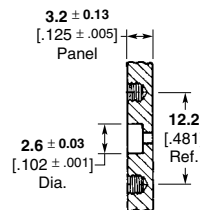

**Detail D\***

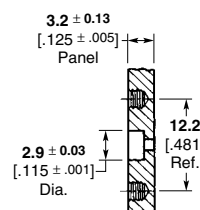

**Detail E\***

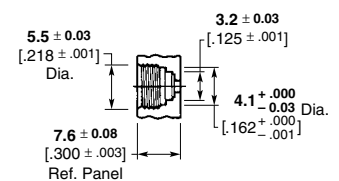

\*Consult appropriate Instruction Sheet for complete mounting details.

**Note:** Part Numbers are RoHS compliant except: ♦ Indicates non-RoHS compliant.



## OSSP Subminiature Modular Blind Mate Connectors

### Product Facts

- Subminiature version of OSP Blind Mate Connectors
- For space savings
- Family of connectors and adapters



OSSP connectors are a sub-miniature version of the OSP blind mate series. Connectors in this series incorporate the design elements of the OSP interface including the float and mis-mate features. OSSP blind mates are about 40% smaller than OSP connectors and are designed to be

used in applications where space is at a premium.

A complete family of OSSP connectors and adapters is available including cable connectors, fixed and float mount panel connectors and hermetic connectors. Rigid mount units will function to specifications up to

$\pm .064$  [ $\pm .0025$ ] radial misalignment with the mating plug connector. Applications requiring greater than  $\pm .064$  [ $\pm .0025$ ] radial misalignment can use either the float design or floating connector plates with guide pins.

### Engineering Data

Impedance —	50 ohms
Frequency —	dc to 28.0 GHz
Temperature Rating —	-65° to 125° C

### Electrical

VSWR —	1.05 + .01f (GHz)
RF Transmission Loss —	.040 x $\sqrt{f}$ (GHz)
Insulation Resistance —	5,000 megohms min.
Contact Resistance —	
Center Contact	6.0 milliohms max.
Outer Contact	3.0 milliohms max.
Outer Contact to Cable	0.5 milliohms max.
Dielectric Withstanding Voltage —	675 volts RMS
Corona Extinction Voltage at 70,000 Ft.—	250 volts min.
RF High Potential at 5 MHz —	675 volts RMS
RF Leakage Interface Only —	-(90-fGHz) dB min. (fully mated)
Power Handling —	300W at 3 GHz (sea level) and room temperature

### Environmental

Corrosion —	Method 101, Condition B, MIL-STD-202
Vibration —	Method 204, Condition D, 20G's, MIL-STD-202
Shock —	Method 213, Condition I, 100G's, MIL-STD-202
Temperature Cycling —	Method 107, Condition B, MIL-STD-202
Moisture Resistance —	Method 106, MIL-STD-202

### Material

Housing —	Corrosion resistant steel Type 303 (stainless) per ASTM A484 and A582
Center Contact —	Beryllium copper per ASTM-B-196
Dielectric —	TFE fluorocarbon per ASTM-D-1457
Gasket (O'Ring) —	MIL-P-25732

### Mechanical

Force to Engage —	3 pounds max.
Force to Disengage —	1.5 pounds max.
Center Contact Retention —	4 pounds min.
Durability —	1,000 Cycles
Radial Misalignment —	
Rigid Mount	$\pm .06$ [ $\pm .0025$ ]
Float Mount	$\pm .51$ [ $\pm .020$ ]

### Mating Characteristics

Jack Connector —		
Center Contact Socket	Oversize test Pin —	.533 + .003 [.0210 + .0001] dia.
	Test Pin Finish —	16 micro inch max.
	Insertion Depth —	.76/1.14 [.030/.045]
	Number of Insertions —	3
Insertion Force	Test Pin —	.528 + .003 [.0208 + .0001] dia.
	Test Pin Finish —	16 micro inch
	Insertion Force —	3 pounds max.
Withdrawal Force	Test Pin —	.495 + .003 [.0195 - .0001] dia.
	Test Pin Finish —	16 micro inch max.
	Insertion Depth —	1.27/1.91 [.050/.075]
	Withdrawal —	1/2 ounce min.

### Finish

Center Contact —	Gold plate per MIL-G-45204, Type II, Class 0 over nickel plate per QQ-N-290, Class 2 or passivate per ASTM-A380
Housing —	Gold plate per MIL-G-45204, Type II, Class 0 over nickel plate per QQ-N-290, Class 2 or passivate per ASTM-A380



**OSSP Subminiature Modular Blind Mate Connectors (Continued)**

**Interface Mating Dimensions**

The connector interface, specifically designed for multiple interconnects, maintains reliable performance over the typical mechanical tolerance required in cost effective packaging.

The interface test data shows excellent performance is maintained with mating gaps up to .015 inch.

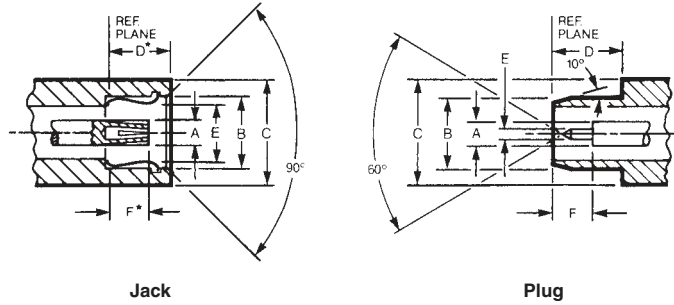

Description	Dimensions						
	A	B	C	D	E	F	
Jack	1.22 0.48	Nom. .154	3.91 Min.	5.33 .210	Ref. 5.00 .197	Nom.* 3.35 .132	Max.* 3.23 .127
Plug	1.22 0.48	Nom. .140	3.56 Nom.	5.33 .210	Ref. 5.00 .199	Min. 0.51 .020	Nom. 3.25 .128

\*With spring bottomed.

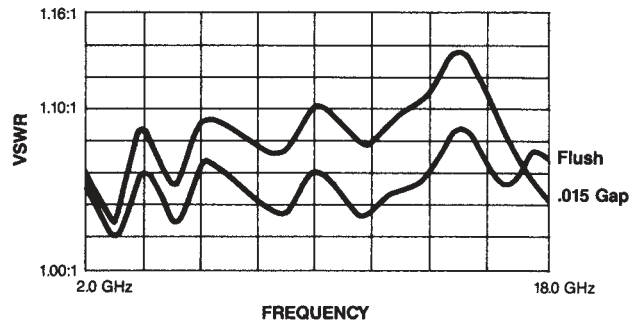

**OSSP Subminiature Modular Blind Mate Connectors (Continued)**  
**For Semi-Rigid Cable, Direct Solder Attachment**

**Bulkhead Feedthrough Cable Plug — Rear Mount**

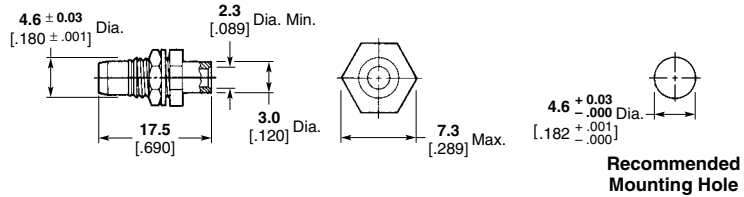

Cable	Plating	Part No.
RG 405/U, 2.16 [.085]	Gold	1059857-1

**Flange Mount Cable Jack — Floating Rear Mount**

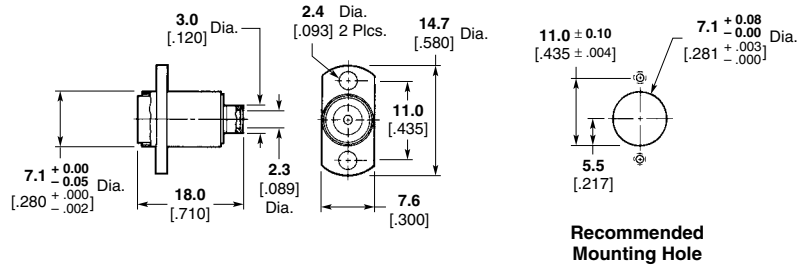

Cable	Part No.
RG 405/U, 2.16 [.085]	1059868-1

Finish: Inner housing that is soldered to cable is gold plated. Outer housing is passivated stainless steel.  
When using semi-rigid cable, it is recommended that a service loop be used to facilitate the float features of the connector.

**Feedthrough Snap-In**

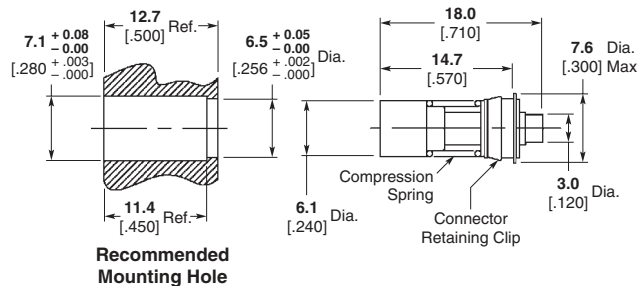

Cable	Part No.
RG 405/U, 2.16 [.085]	1059874-1

**Note:** Part Numbers are RoHS compliant except: ♦ Indicates non-RoHS compliant.

**OSSP Subminiature Modular Blind Mate Connectors (Continued)**  
**For Flexible Cable, Crimp Attachment**

**Bulkhead Feedthrough Cable Plug — Rear Mount**

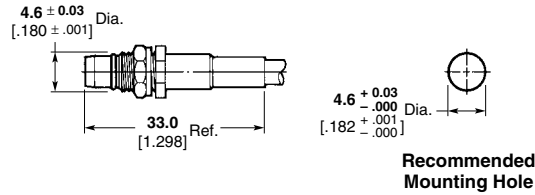

Cable	Plating	Part No.
RG 188/U, 316 Double Braided Only	Passivated Stainless Steel	<b>1059884-1</b>
RG 174/U, 188/U, 316U	Passivated Stainless Steel	<b>1059886-1</b>

**Flange Mount Cable Jack — Floating Rear Mount**

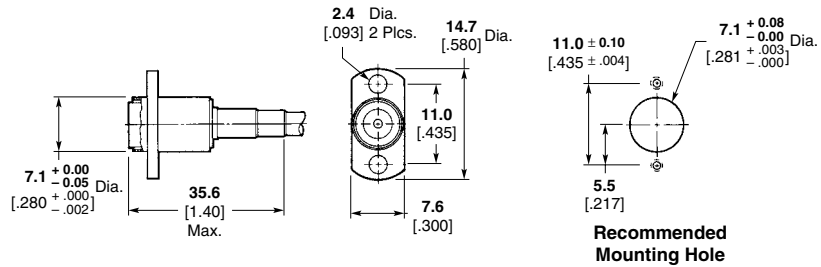

Cable	Plating	Part No.
RG 188/U, 316 Double Braided Only	Passivated Stainless Steel	<b>1059888-1</b>
RG 174/U, 188/U, 316U	Passivated Stainless Steel	<b>1059887-1</b>

**Feedthrough Snap-In Cable Jack**

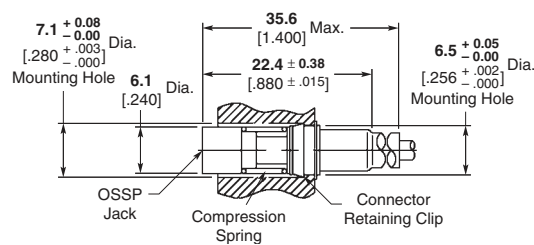

Part No.
<b>1059889-1</b>

**Note:** Part Numbers are RoHS compliant except: ♦ Indicates non-RoHS compliant.

**OSSP Subminiature Modular Blind Mate Connectors (Continued)**  
**For Panel Mount**

**Threaded Panel Feedthrough Plug Receptacle, Straight Terminal**

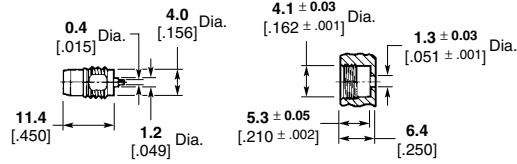

**Recommended Mounting Hole**

Plating	Part No.
Passivated Stainless Steel	<b>1059903-1</b>

**Press-Fit Panel Feedthrough Plug Receptacle**

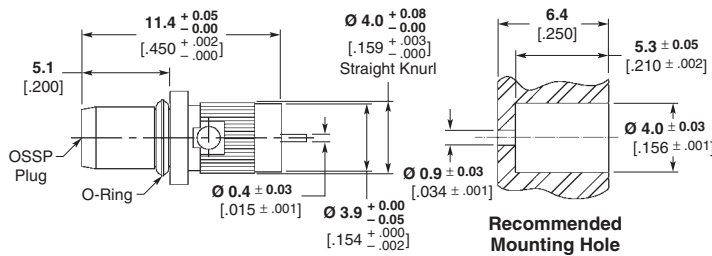

**Recommended Mounting Hole**

Part No.
<b>1059901-1</b>

**Note:** Part Numbers are RoHS compliant except: ♦ Indicates non-RoHS compliant.

**OSSP Subminiature Modular Blind Mate Connectors (Continued)**  
**For Printed Circuit Board Mount**

**Straight Plug Receptacle —  
Captured Contact**

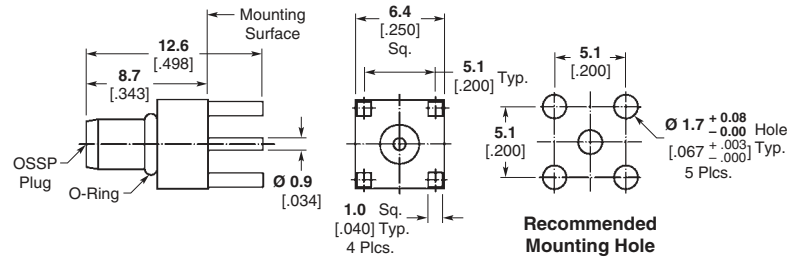

<b>Part No.</b>
<b>1059919-1</b>

**Right-Angle  
Plug Receptacle**

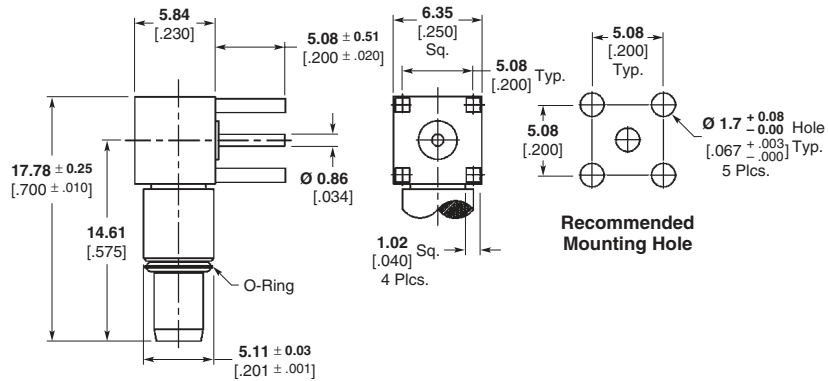

<b>Part Number</b>
<b>1484546-1</b>

**Note:** Part Numbers are RoHS compliant except: ♦ Indicates non-RoHS compliant.

**OSSP Subminiature Modular Blind Mate Connectors (Continued)**  
**Hermetically Sealed**

**Metal to Metal**

**Formable Gasket —  
Panel Feedthrough Plug  
Receptacle**

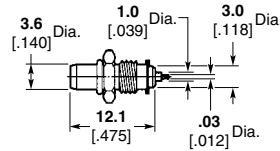

VSWR (GHz)	RF Leakage (dB)	Plating	Part No.
1.06 + .01f	-(85-fGHz)	Gold	<b>1059905-1</b>

Recommended Mounting Hole Detail A at bottom of this page.

**Solder and Braze-In**

**Panel Feedthrough Plug  
Receptacle**

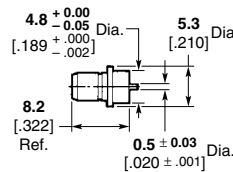

VSWR (GHz)	RF Leakage (dB)	Plating	Part No.
1.06 + .01f	-(85-fGHz)	Gold	<b>1059902-1</b>

Recommended Mounting Hole Detail B at bottom of this page.

**Field Replaceable  
Solder and Braze-In**

**2-Hole Flange Mount  
Plug Receptacle With  
EMI/RFI Gasket**

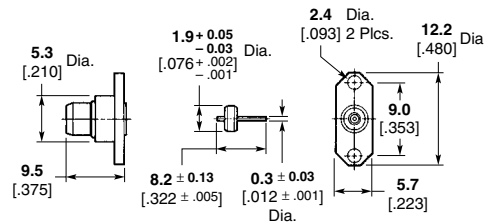

VSWR (GHz)	RF Leakage (dB)	Plating	Part No.
1.06 + .01f	-(85-fGHz)	Passivated Stainless Steel	<b>1059894-1</b>

Recommended Mounting Hole Detail C at bottom of this page.

**Recommended  
Mounting Hole Detail for  
Hermetically Sealed**

**Detail A\***

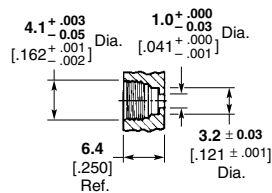

**Detail B\***

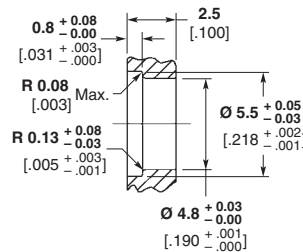

**Detail C\***

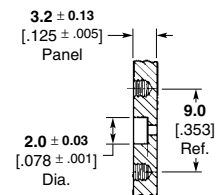



**Note:** Part Numbers are RoHS compliant except: ♦ Indicates non-RoHS compliant.

\*Consult appropriate Instruction Sheet for complete mounting procedure.

## SMB Connectors

### Product Facts

- **SMB offers snap-fit coupling for quick connect/disconnect**
- **Choice of Commercial or High Rel Connectors**
- **50 and 75 Ω MIL-Type connectors available**
- **Straight plugs and jacks are completely crimp terminated**
- **Fast easy cable assembly**
- **Low VSWR**
- **Standard military, commercial or Tyco Electronics tooling**
- **Listed under the Component Program of Underwriters Laboratories Inc., File No. E81956** 
- **PC Board soldered connectors are recognized under the Component Program of Underwriters Laboratories Inc., File No. E81956** 
- **Certified by Canadian Standards Association File No. LR 7189** 

SMB Connectors are available in commercial and high rel versions. They are ideally suited for circuit miniaturization and are offered in a wide range of configurations including plugs, right-angle plugs, jacks, bulkhead jacks and adapters, as well as printed circuit board and solder jacks.

Termination costs are kept to a minimum using plugs and jacks with a crimp center contact and hex crimp outer braid. Both hand held tooling and pneumatic bench-mounted tooling is available. Easily assembled right-angle plugs have a hex crimp on the outer braid ferrule and bifurcated solder center contacts.

Tyco Electronics' 75 Ohm BT 43 SMB Connectors feature unique spring mating with snap-fit couplings for quick connect/disconnect. These connectors are designed to be intermateable with 75 Ohm SMB MIL-C-39012 connectors. They also feature reliable dual crimp cable terminations.



**Packaging** — All connectors are packaged individually unless otherwise noted under the "Military No. and/or Comments" column in the connector specifications chart.

### Between Series Adapters

For SMB Between Series Adapters, please see pages 251-260.

## SMB Connector Specifications

### Electrical Characteristics

**Impedance** — 50 ohms and 75 ohms, nominal

**Frequency Range** — 0 to 4.0 GHz

**Voltage Rating (VRMS)** —

	Sea Level	70,000 Feet
50 ohm connectors for RG 178/U series cable	300	75
50 ohm connectors for RG 316/U series cable	400	100
75 ohm connectors for RG 179/U series cable	300	75
75 ohm connectors for RG 195/U series cable	500	125

**Insulations Resistance** — 1000 megohms min.

**Contact Resistance** — (milliohms max.)

	Initial	After Environment
Center contact	6.0	8.0
Outer contact	1.0	1.5
Braid to body	1.0	N/A

**Contact Current Rating** — 1.5 amps DC max.

**Voltage Standing Wave Ratio (VSWR)** — to 4.0 GHz or 80% of upper cutoff frequency of the cable, whichever is lower.

Cable	Mating Engagement	
	Straight	Right-Angle
RG 178/U Series	1.30 + .04F	1.45 + .06F
RG 316/U Series	1.25 + .04F	1.35 + .04F

F=GHz, does not apply to 75 ohm connectors.

### RF High Potential Withstanding Voltage

**Frequency** — 5 MHz

**Leakage Current** — N/A

50 ohm connectors for RG 178/U series cable	675 VRMS
50 ohm connectors for RG 316/U series cable	950 VRMS
75 ohm connectors for RG 179/U series cable	950 VRMS
75 ohm connectors for RG 195/U series cable	1225 VRMS

**RF Leakage** — -55 dB min. at 2-3 GHz

**Insertion Loss** — .30dB max. at 3 GHz

### Mechanical Characteristics

**Engagement Forces** — 14 lbs. [62.3 N] maximum engagement initially.

After 500 matings, 14 lbs. [62.3 N] maximum engagement and 2 lbs. [8.8 N] minimum disengagement for all of SMBs.

**Cable Attachment** —

**Straight Connectors** — Crimp, both center contact and braid

**Right-Angle Connectors** — Crimp on braid and bifurcated solder center contact

**Durability** — 500 cycles per MIL-C-39012

**Contact Captivation** — When captivated, the contacts will withstand 4.0 lbs. minimum axial force.

**Cable Retention** — When properly assembled to the compatible braided coaxial cable, the retention is equal to the breaking strength of the cable.

**Marking** — Per MIL-STD-130

### Environmental Characteristics

**Temperature Rating** — -65°C to +165°C

**Corrosion (salt spray)** — MIL-STD-202, Method 101, test condition B, 5% salt solution

**Vibration High Frequency** — MIL-STD-202, Method 204, test condition B (15 G's)

**Shock** — MIL-STD-202, Method 213, test condition B, 75 G's at 6 milliseconds, 1/2 sine

**Thermal Shock** — MIL-STD-202, Method 107, test condition B, except high temperature shall be +85°C. High temperature shall be +200°C for connectors using 200°C cables.

**Moisture Resistance** — MIL-STD-202, Method 106, when interface gasket is used. No measurements of high humidity. Insulation resistance shall be 200 megohms minimum within five minutes after removal from humidity.

**Durability Test** — Conducted per MIL-C-39012 Reg. Para. 3.15, Method Para. 4.6.12

### Materials

**Body, Body Components and Male Contacts** — Brass, half hard, per QQ-B-626, Alloy 360, Zinc per QQ-Z-363

**Female Contacts** — Beryllium copper per QQ-C-530, heat treated per MIL-H-7199

**Insulators** — TFE fluorocarbon per ASTM D 1710, Type 1, Grade 1

**Lockwashers** — Phosphor bronze per QQ-B-750

**Crimp Ferrule** — Annealed copper alloy per WW-T-799

**Gaskets** — Silicone rubber per ZZ-R-765, Class 11B, Grade 65-75

### Plating

**Center Contacts** — 0.00127 [0.00050] min. Gold per MIL-G-452048 Type 1, Grade C, Class 1, over 0.00254 [0.00100] min. nickel per QQ-N-290

**Other Metal Parts** — Gold, Nickel or Solder plated to meet the Finish and Corrosion requirements of MIL-C-39012



**SMB Connectors, 50 Ohm**

**Straight Plugs**

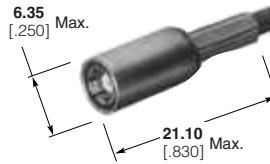

RG/U Cable	Center Contact Plating	Outer Contact Plating	Other Metal Parts Plating	Dielectric	Style	Part No.
178, 178A, 178B, 196, 196A	Gold	Gold	Nickel	PTFE	MIL Type	<b>413985-6</b>
174, 316, 188, 188A	Gold	Gold	Gold	PTFE	MIL Type	<b>413985-1</b>
	Gold	Gold	Nickel	PTFE	MIL Type	<b>413985-3</b>
	Gold	Nickel	Nickel	PTFE	MIL Type	<b>413985-7</b>
	Gold	Gold	Nickel	PTFE	Die Cast	<b>414946-1</b>
179, 179A, 179B, 161, 187, 187A, BELDEN 9221	Gold	Nickel	Nickel	PTFE	Die Cast	<b>5414946-2</b>
	Gold	Gold	Nickel	PTFE	MIL Type	<b>1-413985-1</b>
	Gold	Gold	Nickel	PTFE	Die Cast	<b>5414946-5</b>
RG 316, 188 Double Braid	Gold	Nickel	Nickel	PTFE	Die Cast	<b>5414946-6</b>
	Gold	Gold	Gold	PTFE	MIL Type	<b>413985-2</b>
	Gold	Gold	Nickel	PTFE	MIL Type	<b>413985-4</b>
	Gold	Gold	Nickel	PTFE	Die Cast	<b>5414946-3</b>
	Gold	Nickel	Nickel	PTFE	MIL Type	<b>413985-8</b>

**Right-Angle Plugs**

**MIL Type**

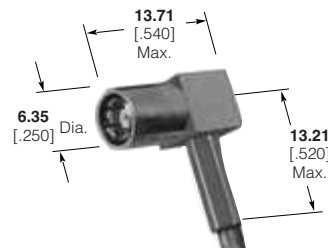

**Die Cast**



RG/U Cable	Center Contact Plating	Outer Contact Plating	Other Metal Parts Plating	Dielectric	Style	Part No.
178, 178A, 178B, 196, 196A	Gold	Gold	Gold	PTFE	MIL Type	<b>414002-7</b>
	Gold	Gold	Nickel	PTFE	MIL Type	<b>414002-8</b>
	Gold	Gold	Nickel	PTFE	Die Cast	<b>5414363-8</b>
174, 316, 188, 188A, 179, 179A, 179B, 161, 187, 187A, BELDEN 9221	Gold	Gold	Gold	PTFE	MIL Type	<b>414002-1</b>
	Gold	Gold	Nickel	PTFE	MIL Type	<b>414002-3</b>
	Gold	Nickel	Nickel	PTFE	MIL Type	<b>414002-5</b>
	Gold	Gold	Nickel	PTFE	Die Cast	<b>5414363-3</b>
RG 316, 188 Double Braid	Gold	Nickel	Nickel	PTFE	Die Cast	<b>5414363-5</b>
	Gold	Gold	Gold	PTFE	MIL Type	<b>414002-2</b>
	Gold	Gold	Nickel	PTFE	MIL Type	<b>414002-4</b>
	Gold	Gold	Nickel	PTFE	Die Cast	<b>5414363-4</b>

BELDEN is a trademark of Belden Wire and Cable Company.

**Note:** Part Numbers are RoHS compliant except: ♦ Indicates non-RoHS compliant.

**SMB Connectors, 50 Ohm (Continued)**

**Straight Jacks**

**Commercial Jack**

**MIL Type Jack**

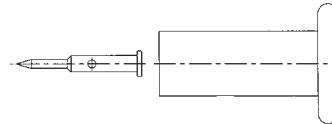
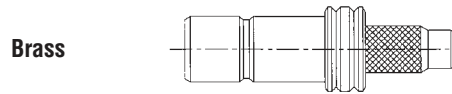
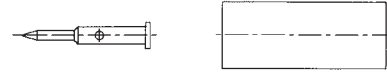
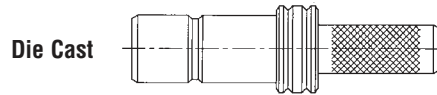
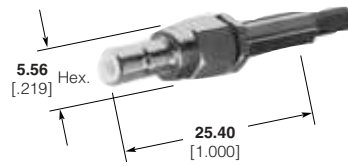

RG/U Cable	Center Contact Plating	Body Plating	Dielectric	Style	Jack Part No.
178, 178A, 178B, 196, 196A	Gold	Nickel	PTFE	MIL Type	<b>5414170-2</b>
174, 316, 188, 188A	Gold	Nickel	PTFE	MIL Type	<b>5414170-1</b>
	Gold	Nickel	PTFE	Die Cast	<b>414948-1</b>
RD 316, 188 Double Braid	Gold	Nickel	PTFE	Commercial	<b>414948-3</b>

**Bulkhead Jacks**

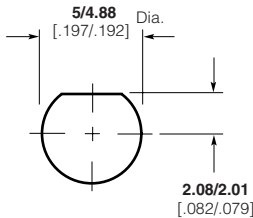

Maximum Panel Thickness **2.36** [.093]  
**Recommended Panel Cutout for Bulkhead Jack and Adapter**

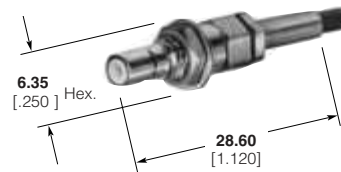

RG/U Cable	Center Contact Plating	Body Plating	Dielectric	Style	Bulkhead Jack Part No.
174, 316, 188, 188A	Gold	Nickel	PTFE	Commercial	<b>5415006-1</b>
	Gold	Nickel	PTFE	Commercial	<b>5228217-1</b>
RD 316, 188 Double Braid	Gold	Nickel	PTFE	Commercial	<b>5415006-2</b>

**Bulkhead Jack Adapter (Jack-Jack)**

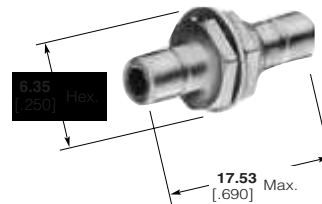

Type	Center Contact Plating	Body Plating	Dielectric	Style	Part No.
Jack-To-Jack	Gold	Nickel	PTFE	MIL Type	<b>228553-1</b>
	Gold	Gold	PTFE	MIL Type	<b>228553-2</b>

**Note:** Part Numbers are RoHS compliant except: ♦ Indicates non-RoHS compliant.

**SMB Connectors, 50 Ohm (Continued)**

**PC Board Vertical Jacks**

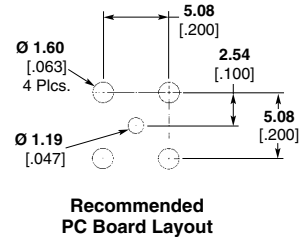
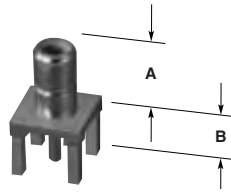

**Jacks**

Type	Center Contact Plating	Body Plating	Dim. A	Dim. B	Dielectric	Style	Part No.
—	Gold	Gold	7.62 .300	3.94 .155	PTFE	MIL Type	413990-1
—	Gold	Nickel	7.62 .300	3.94 .155	PTFE	MIL Type	413990-2
—	Gold	Nickel	10.16 .400	2.54 .100	PTFE	MIL Type	414612-2
—	Gold	Tin	3.94 .155	8.25 .325 Max.	PTFE	Brass, Stamped	5221111-1

**PC Board Vertical Plugs**

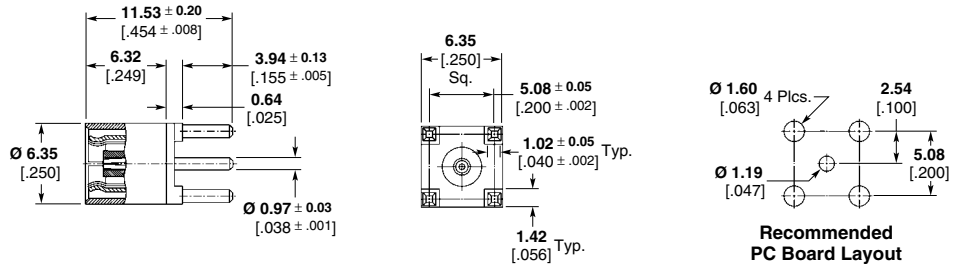
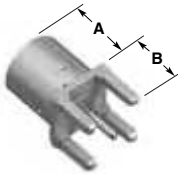

**Plugs**

Type	Center Contact Plating	Body Plating	Dim. A	Dim. B	Dielectric	Recommended PC Board Layout	Style	Part No.
Low Profile (Plug) Mated Pair	Gold	Nickel	3.94 .155	7.62 300	PTFE	B	MIL Type	415774-1

**Note:** Part Numbers are RoHS compliant except: ♦ Indicates non-RoHS compliant.

**SMB Connectors, 50 Ohm (Continued)**

**PC Board,  
Right-Angle Jacks**

**Jack Low Profile**

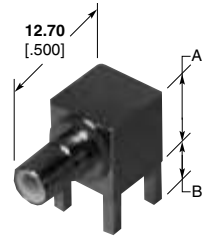

**Jack with Standoff Pads**

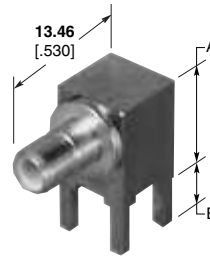

**Bulkhead Jack**

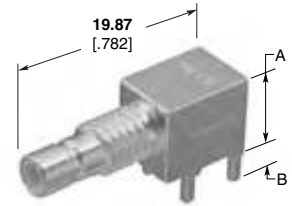

**Jacks**

Type	Center Contact Plating	Interface Body Plating	PCB Leg Plating	Dielectric	Dim. A	Dim. B	Style	Recommended PC Board Layout	Part No.
Low Profile	Gold	Gold	Gold	PTFE	7.11 .280	3.94 .155	MIL Type	A	413996-2
	Gold	Nickel	Nickel	PTFE	7.11 .280	3.94 .155	MIL Type	A	413996-4
	Gold	Gold	Gold	PTFE	7.11 .280	2.79 .110	Die Cast	A	415340-1
	Gold	Gold	Gold	PTFE	8.76 .345	2.79 .110	Die Cast	A	415672-1
With Standoff Pads	Gold	Gold	Gold	PTFE	8.51 .335	3.94 .155	MIL Type	A	414026-2
	Gold	Nickel	Nickel	PTFE	8.76 .345	3.94 .155	MIL Type	A	414026-3
	Gold	Nickel	Tin-Lead	PTFE	8.76 .345	3.94 .155	Die Cast	A	5414337-1
	Gold	Nickel	Nickel	PTFE	8.76 .345	2.79 .110	Die Cast	B	5415379-1*
Bulkhead	Gold	Gold	Gold	PTFE	8.51 .335	3.94 .155	Die Cast	A	415381-1♦
	Gold	Nickel	Nickel	PTFE	8.76 .345	3.94 .155	MIL Type	A	414026-3
Commercial	Gold	Nickel	Tin	Polypropylene	9.78 .385	3.94 .155	Brass, Stamped	C	5228435-1
Bulkhead	Gold	Gold	Gold	PTFE	7.67 .302	2.79 .110	Die Cast	A	414963-1
Bulkhead	Gold	Gold	Gold	PTFE	7.67 .302	2.79 .110	Die Cast	A	1274330-1

\* 5 leg design

**PC Board,  
Right-Angle Plug**

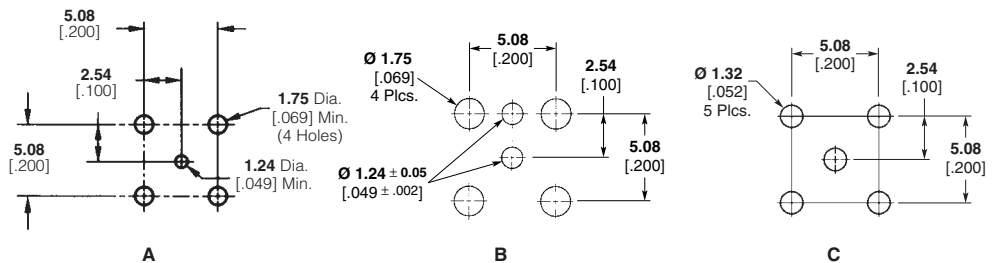
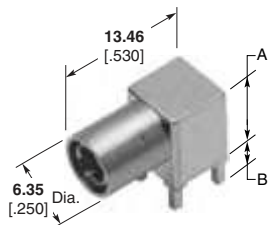

**Recommended  
PC Board Layouts**

**Plugs**

Center Contact Plating	Interface Body Plating	PCB Leg Plating	Dielectric	Dim. A	Dim. B	Style	Recommended PC Board Layout	Part No.
Gold	Nickel	Nickel	PTFE	8.76 .345	2.79 .110	Die Cast	B	415380-1*
Gold	Nickel	Tin	PTFE	8.76 .345	3.94 .155	Die Cast	A	5414338-1

\* 5 leg design

**Note:** Part Numbers are RoHS compliant except: ♦ Indicates non-RoHS compliant.

**SMB Connectors, 50 Ohm (Continued)**

**Bulkhead PC Board Jack,  
Solder Receptacle Kits**

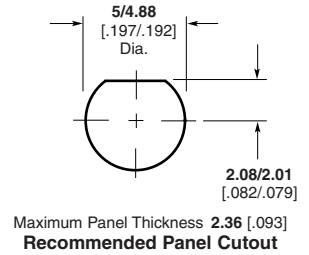
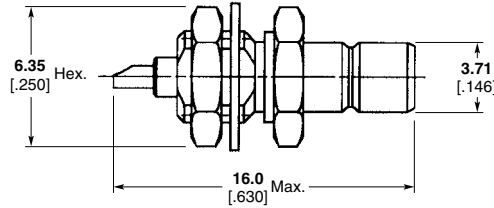

**Kit Includes Lockwasher  
and Jam Nut**

**Lockwasher and Jam Nut**



Part No.  
415001-2



Part No.  
414969-2

Type	Center Contact Plating	Body Plating	Dielectric	Style	Kit Part No.
Front Mount	Gold	Nickel	PTFE	MIL Type	228216-1*
Rear Mount	Gold	Nickel	PTFE	MIL Type	228215-1*

\*includes Jam Nut and Lockwasher

**SMB Receptacle Jack**

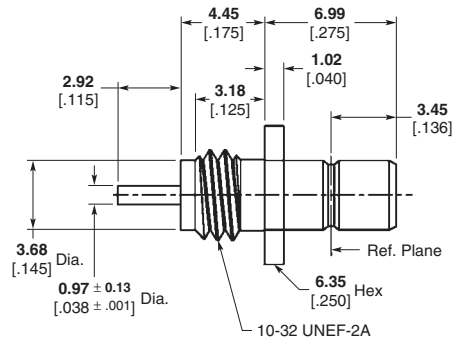

Type	Center Contact Plating	Body Plating	Dielectric	Style	Part No.
Front Mount	Gold	Nickel	PTFE	MIL Type	414895-1

**Note:** Part Numbers are RoHS compliant except: ♦ Indicates non-RoHS compliant.

## SMB Connectors, Mini 75 Ohm

### Product Facts

- Industry standard for miniature 75 ohm SMB
- SMB offers snap-fit coupling for quick connect/disconnect
- Suitable for high density applications
- Fast easy cable assembly
- Low VSWR
- Connectors offer consistent mating and unmating forces
- Straight plugs and jacks are completely crimp terminated
- Low cost

Mini 75 ohm SMB connectors are ideally suited for circuit miniaturization in communication, broadband and switching equipment as well as a variety of other applications.

They offer the same low consistent mating/unmating force as Tyco Electronics standard SMB products and therefore, outer contact resistance values are maintained from connector to connector.

Standard military, commercial or Tyco Electronics tooling can be used to terminate these products. Cost effective assembly of the straight plugs is completed with a crimp center contact and hex crimp on the outer braid. Right-angle plugs have a hex crimp on the outer braid ferrule and bifurcated solder center contacts.



### Electrical Characteristics

**Impedance** — 75 ohms

**Frequency Range** — 0 to 4.0 GHz

**Insulation Resistance** — 1000 megohms

**Contact Current Rating** — 1.5 amps DC max.

### Mechanical Characteristics

**Engagement Forces** — Initial—14.0 lbs. [62.3 N] maximum engagement.  
After 500 matings, 14.0 lbs. [62.3 N] maximum engagement.  
Durability—500 cycles

### Environmental Characteristics

**Temperature Rating** — -65°C to +165°C

**SMB Connectors, Mini 75 Ohm (Continued)**

**Straight Plug**

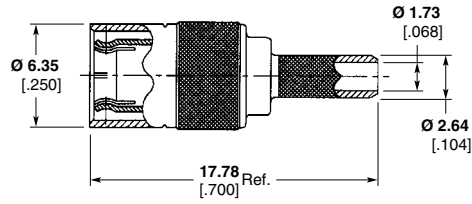

RG Cable	Center Contact Plating	Outer Contact Plating	Body Plating	Part No.
179, 187	Gold	Gold	Nickel	5415487-1
179, 187	Gold	Nickel	Nickel	5415487-2
RD 179	Gold	Nickel	Nickel	5415487-3

**Right-Angle Plug**

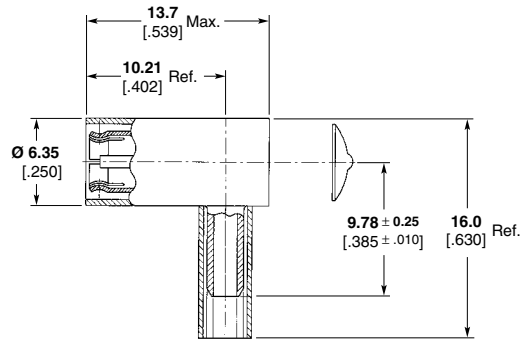

RG Cable	Center Contact Plating	Outer Contact Plating	Body Plating	Part No.
179, 187	Gold	Nickel	Nickel	5415484-1
179, 187	Gold	Gold	Nickel	5415484-2
RD 179	Gold	Gold	Nickel	5415484-3

**Bulkhead Jack**

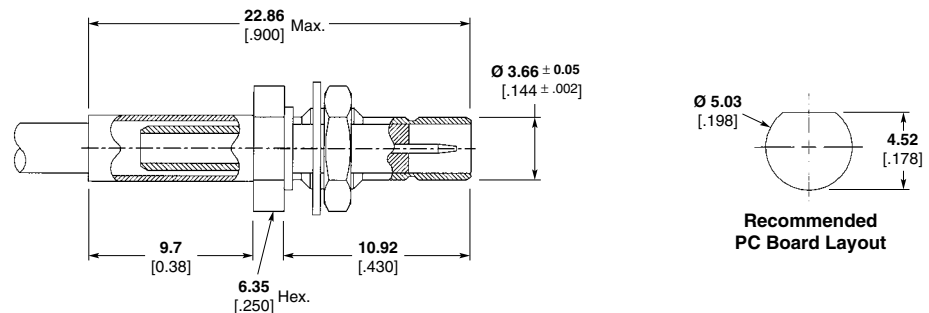

RG Cable	Center Contact Plating	Body Plating	Part No.
179, 187	Gold	Nickel	415500-1

**Note:** Part Numbers are RoHS compliant except: ♦ Indicates non-RoHS compliant.

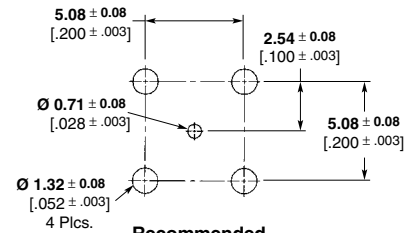
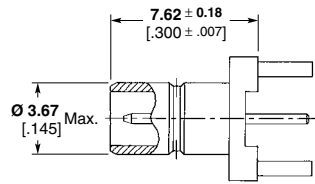
**SMB Connectors, Mini 75 Ohm (Continued)**
**Vertical PC Board Jacks**

**Recommended  
PC Board Layout**

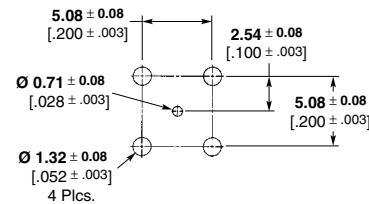
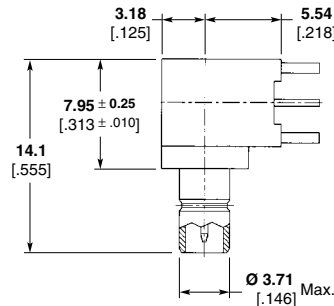
Leg Length	Center Contact Plating	Body Plating	Part No.
2.11 .083	Gold	Gold Flash	415504-2
3.05 .120	Gold	Gold	415504-3
3.05 .120	Gold	Gold Flash	415504-4

**Right-Angle PC Board Jacks**

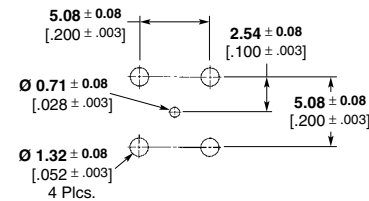
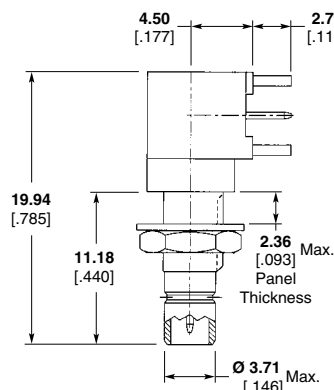
**Recommended  
PC Board Layout**

Leg Length	Center Contact Plating	Body Plating	Part No.
2.79 .110	Gold	Gold	415490-1
2.79 .110	Gold	Nickel	415490-2
2.11 .083	Gold	Gold	415490-3
2.11 .083	Gold	Nickel	415490-4

**Right-Angle PC Board Bulkhead Jacks**

**Recommended  
PC Board Layout**

Leg Length	Center Contact Plating	Body Plating	Part No.
2.79 .110	Gold	Nickel	415377-1
2.79 .110	Gold	Gold	415377-2
2.79 .110	Gold	Gold	415377-5*

**Note:** Part Numbers are RoHS compliant except: ♦ Indicates non-RoHS compliant.

\*Isolated.



## SMB Connectors, 75 Ohm BT 43 (SMZ)

### Product Facts

- Widely used in data transmission and telecommunication applications
- BT 43 connector developed from the SMB range and feature snap-on and latching variant
- Most BT 43 connectors are available as fully crimped connectors.
- BT 43 and 75  $\Omega$  connectors available in solder and crimp versions

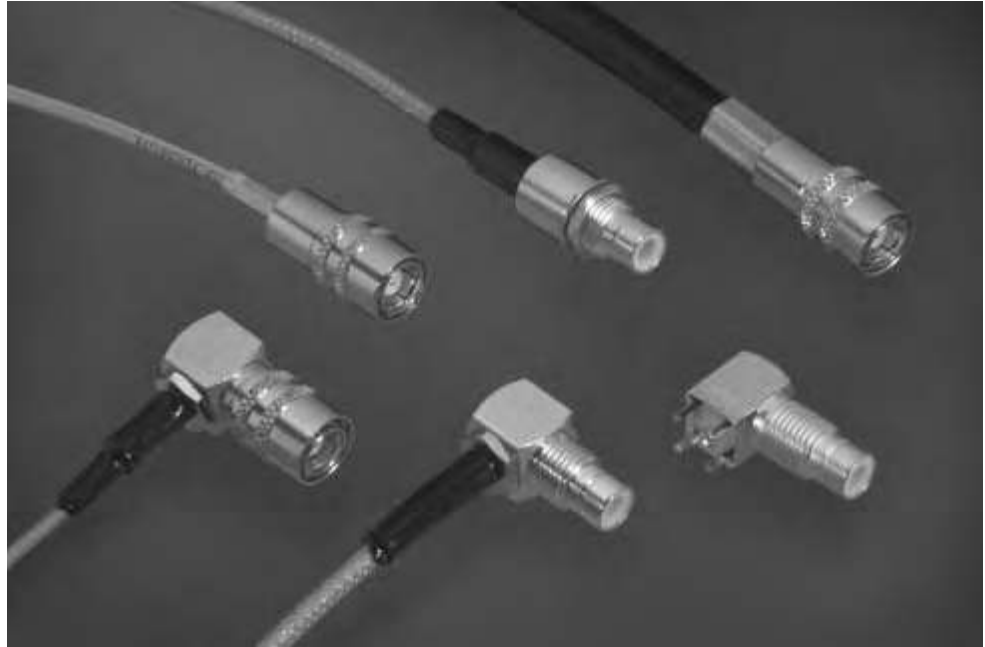

The Tyco Electronics range of 75 ohm SMB (SMZ) connectors are designed to meet the increasing demands of the Telecommunications market, and are designed in accordance with BS9210 F0022.

### Specifications

- Max working voltage (dc)** — 500 V
- Max proof voltage (dc)** — 1.5 kV
- Contact resistance (inner)** — 5 milliohm
- Contact resistance (outer)** — 1 milliohm
- Bodies and other parts** — Brass

### Female center contacts —

Copper Alloy

### Male center contacts —

Copper Alloy

### Outer contacts — BeCu

### Plating —

Contacts and critical surfaces — Gold

Other parts — Nickel

**Insulators** — P.T.F.E.

**SMB Connectors, 75 Ohm BT 43 (SMZ) (Continued)**

**Straight Plugs, Snap-On**

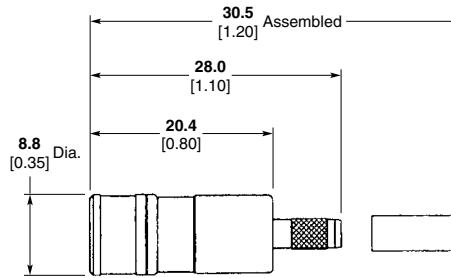

Cable Type	Termination Method		Body Plating	Part No.
	Inner	Outer		
RG 179B/U	Crimp	Crimp	Selective Gold	1311097-1
BT2002	Crimp	Crimp	Selective Gold	1311098-1

**Straight Plugs, Latching, Crimp/Crimp**

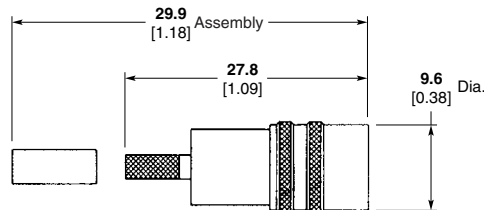

Cable Type	Body Plating	Part No
RG 179B/U	Selective Gold	1311099-1
BT2003	Selective Gold	1311100-1
BT2002	Selective Gold	1311101-1
BT2001	Selective Gold	1311696-1
BT3002, TZC75024	Selective Gold	1311102-1
RG 59B/U, RG 140/U, URM90	Selective Gold	1313507-1

**Note:** Part Numbers are RoHS compliant except: ♦ Indicates non-RoHS compliant.

**SMB Connectors, 75 Ohm BT 43 (SMZ) (Continued)**

**Right-Angle Socket,  
Snap-On, Solder/Crimp**

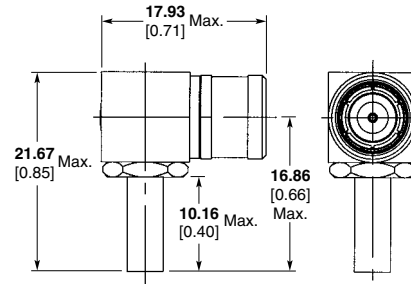

Cable Type	Body Plating	Part No
RG 179B/U	Selective Gold	<b>1311103-1</b>
BT3002, TZC75024	Selective Gold	<b>1311104-1</b>

**Right-Angle Socket,  
Latching, Solder/Crimp**

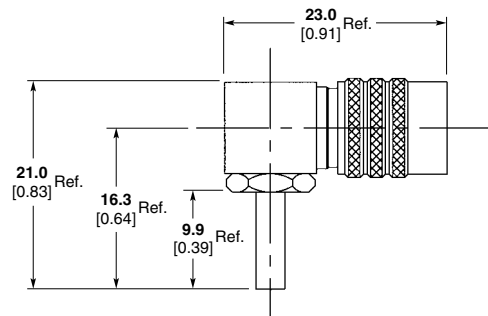

Cable Type	Body Plating	Part No
RG 179B/U	Selective Gold	<b>1311106-1</b>
BT2003	Selective Gold	<b>1311698-1</b>
BT3002, TZC75024	Selective Gold	<b>1311111-1</b>
RG 59B/U, RG 140/U	Selective Gold	<b>1313508-1</b>

**Straight Free Plug,  
Crimp/Crimp**

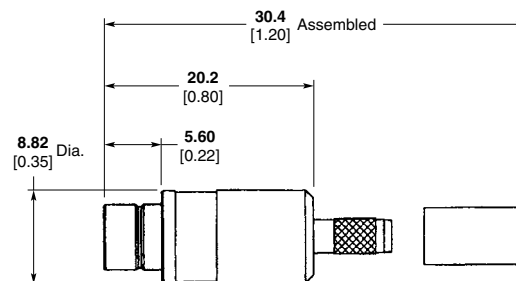

Cable Type	Body Plating	Part No
RG 179B/U	Selective Gold	<b>1408041-1</b>

**Note:** Part Numbers are RoHS compliant except: ♦ Indicates non-RoHS compliant.

**SMB Connectors, 75 Ohm BT 43 (SMZ) (Continued)**

**Straight Bulkhead Plug**

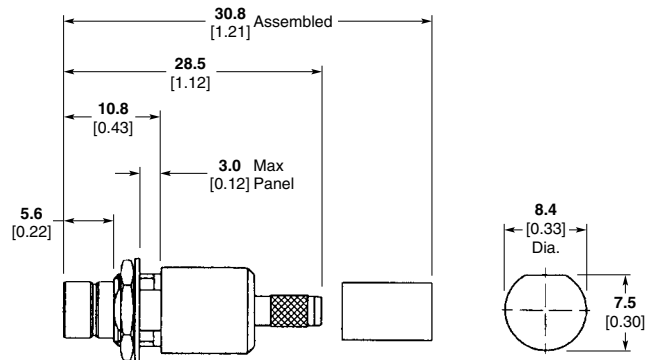

**Mounting Detail**

Cable Type	Termination Method		Body Plating	Part No.
	Inner	Outer		
RG 179B/U	Crimp	Crimp	Selective Gold	1311120-1
BT500B, BT2003, BT2003A	Crimp	Crimp	Selective Gold	1311701-1
BT3002, TZC75024	Crimp	Crimp	Selective Gold	1311122-1

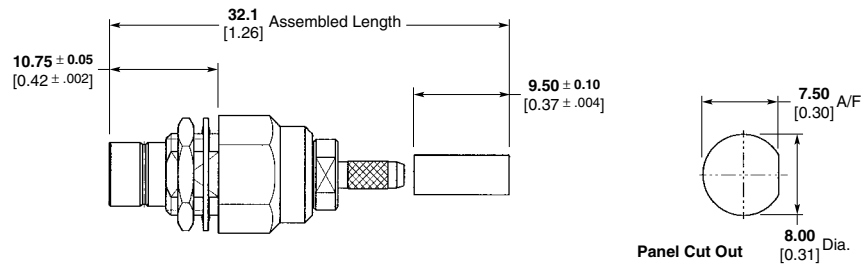

Cable Type	Termination Method		Body Plating	Part No.
	Inner	Outer		
3M: 043, 031C, CS4456, Gore: GCX	Crimp	Crimp	Selective Gold	1313511-1

**Right-Angle Bulkhead Plug, Solder/Crimp**

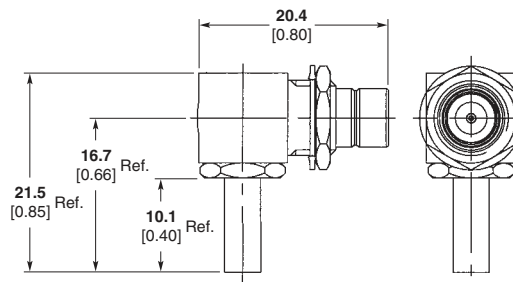

Cable Type	Body Plating	Part No
RG 179B/U	Selective Gold	1311115-1

**Note:** Part Numbers are RoHS compliant except: ♦ Indicates non-RoHS compliant.

**SMB Connectors, 75 Ohm BT 43 (SMZ) (Continued)**

**DDF Plug,  
Crimp/Crimp**

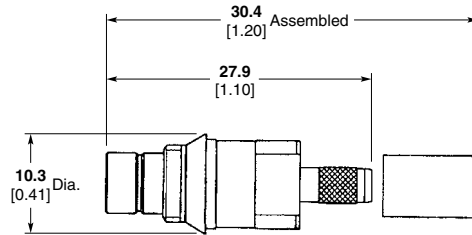

Cable Type	Body Plating	Part No
RG 179B/U	Selective Gold	1327083-1
BT2003	Selective Gold	1311117-1
BT2002	Selective Gold	1311700-1
B2001	Selective Gold	1313883-1
BT3002, TZC75024	Selective Gold	1311118-1
RG 59B/U, RG 140/U, URM90	Selective Gold	1313887-1

**DDF Plug,  
Crimp/Crimp**

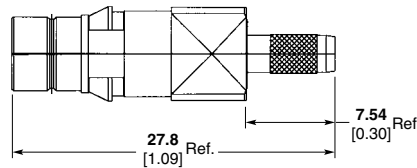

Cable Type	Body Plating	Part No
RD179, 124431 (Filotex), 1366 (Orebro), K02253D-1, K02253-2 (Shuner)	Selective Gold	1314422-1

**PC Board Plug 43/1D**

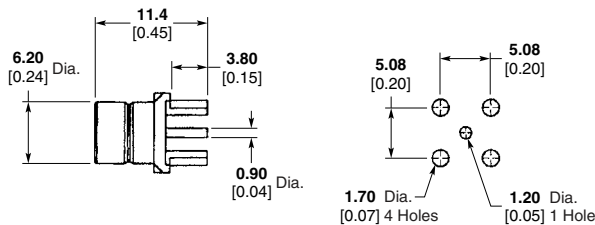

Mounting Detail

Body Plating	Part No.
Selective Gold	1311125-1

**PC Board Plug 43/1E**

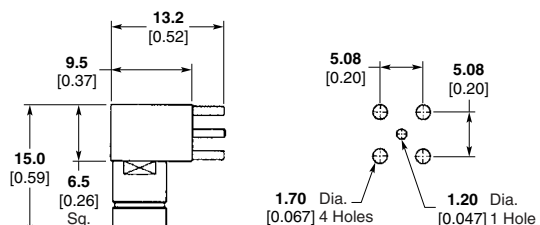

Mounting Detail

Body Plating	Part No.
Selective Gold	1314103-1

**Right-Angle PC Board Plug**

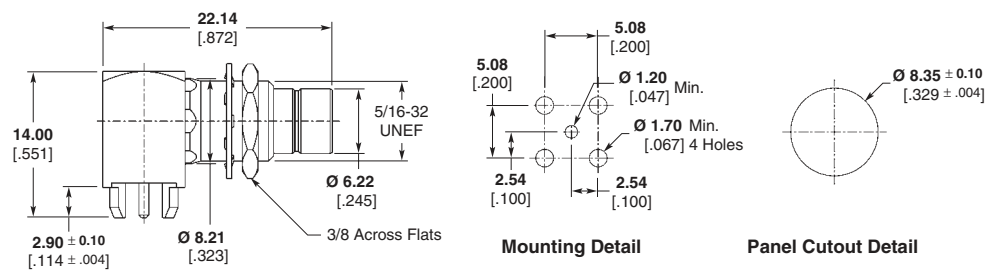

Mounting Detail

Panel Cutout Detail

Part No. 1314102-1

**Note:** Part Numbers are RoHS compliant except: ♦ Indicates non-RoHS compliant.

**SMB Connectors, 75 Ohm BT 43 (SMZ)** (Continued)

**Straight Adapter  
Plug-Plug**

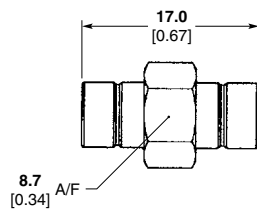

Part No. 1313364-1

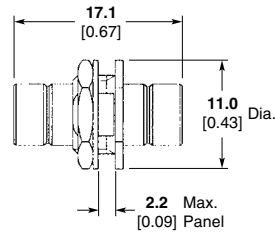

Part No. 1311127-1

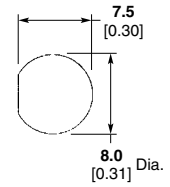

Mounting Detail

Body Plating	Part No.
Selective Gold	1313364-1
Selective Gold	1311127-1

**Tester 430A**

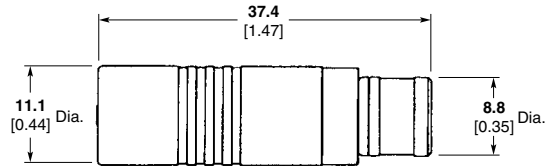

Body Plating	Part No.
Selective Plating	6-1311703-1

**Extraction Tool 65A**

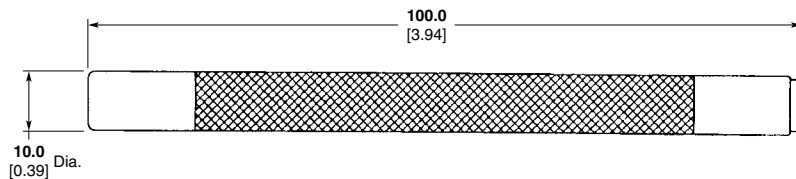

Part No.
1311164-1 ◆

**Note:** Part Numbers are RoHS compliant except: ◆ Indicates non-RoHS compliant.

## SMB Connector Crimp Tooling

50 Ω/75 Ω

RG/U Cable	Commercial Connector Tooling						MIL Type Connector Tooling						
	Center Contact Crimp Tooling			Braid Crimp Tooling			Center Contact Crimp Tooling			Braid Crimp Tooling			
	Dies for Tyco Electronics PRO-CRIMPER Hand Tool Number	MIL-C-22520/2-01 Tool DANIELS* Positioner	Position	Dies for Tyco Electronics PRO-CRIMPER Hand Tool Number	Position	MIL-C-22520/5-01 Tool DANIELS* Hex Crimp Die	DANIELS* Hand Tool	DANIELS* Positioner Number	Selector Position	Dies for Tyco Electronics PRO-CRIMPER Hand Tool Number	Position	DANIELS Hand Tool	Hex Die Across Flats
178, 178A, 178B, 196, 196A	58489-1	Female-K699 Male-K727	4	58489-1	A&B	Y624	AFM8	Female-K699 Male-K727	4	58483-1	A	HX4-1637	2.67 .105
Double Braid 178, 196	—	—	—	—	—	—	AFM8	Female-K699 Male-K727	4	58483-1	B	HX4-1637	3.25 .128
174, 316 188, 188A	58489-1	Female-K699 Male-K727	4	58489-1	A	Y444	AFM8	Female-K699 Male-K727	4	58483-1	B	HX4-1637	3.25 .128
Double Braid 174, 316, 188	58489-1	Female-K699	4	58489-1	C	Y196 Location A	AFM8	Female-K699	4	58483-1	C	HX4-1637	3.84 .151
Double Braid 174, 316, 188	58489-1	Male-K727	4	58489-1	C	Y196 Location A	AFM8	Solder	—	58483-1	B	HX4-1637	3.25 .128
179, 179A 179B, 161, 187, 187A, BELDEN 9221	58489-1	Female-K699	4	58489-1	A	Y444	AFM8	Female-K699	4	58483-1	B	HX4-1637	3.25 .128
179, 179A 179B, 161, 187, 187A, BELDEN 9221	58489-1	Male-K727	4	58489-1	A	Y444	—	Solder	—	58483-1	B	HX4-1637	3.25 .128
180, 180A 180B	—	—	—	—	—	—	—	Solder	—	58483-1	C	HX4-1637	3.84 .151
<b>Mini SMB 75 ohm</b>													
179, 187	—	Female-K699	—	58483-1	B	HX4-1637	—	—	—	—	—	—	—
179, 187	—	Solder Center Contact	—	58483-1	B	HX4-1637	—	—	—	—	—	—	—

**Note:** All 75 ohm SMB connectors have a solder center contact.

\* DANIELS Manufacturing Corporation Telephone: 407-855-6161  
6103 Anno Avenue FAX: 407-855-6884  
Orlando, Florida 32809

**Note:** Equivalent military tool part numbers—  
M22520/5-01 – DANIELS Hand Tool HX4  
M22520/5-33 – DANIELS Die Set Y136  
M22520/5-37 – DANIELS Die Set Y138  
M22520/5-41 – DANIELS Die Set Y140  
M22520/5-03 – DANIELS Die Set Y196  
M22520/2-01 – DANIELS Hand Tool AFM8

BELDEN is a trademark of Belden Wire and Cable Company.

DANIELS is a trademark of Daniels Manufacturing Corporation.

**Note:** Part Numbers are RoHS compliant except: ♦ Indicates non-RoHS compliant.

## SMC Connectors

### Product Facts

- Three-piece designs
- Fast, clean cable assembly
- Connector bodies preassembled
- Solderless termination —no danger of heat damage
- Center conductor and braid terminated with same tool
- Low noise level
- Miniature screw-on coupling
- PTFE dielectric

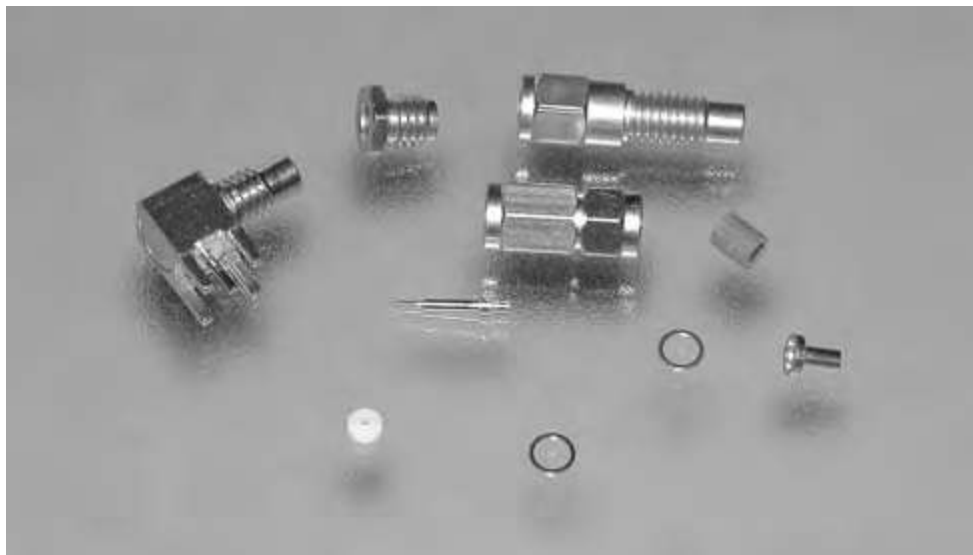

The SMC Connector is miniature and light-weight, especially designed for use in critical applications where limited space and vibration are of major concern.

This connector is designed in accordance with the requirements of Specification MIL-C-39012, Class II, Category B to assure the highest standards of electrical and mechanical performance. It has a constant impedance of 50 ohms, a voltage rating of 350 volts and provides excellent operation at frequencies up to 10 GHz. It also has a threaded coupling and can be used with a wide range of miniature coaxial cable sizes including RG 174, 197, 187, 188 and 316.

### Materials

**Brass** — QQ-B-626  
**Beryllium Copper** — QQ-C-530  
**Copper** — QQ-C-576  
**PTFE Insulation** — MIL-P-19468

### Plating

**Gold** — MIL-G-45204

### Electrical Characteristics

**Nominal Impedance** — 50 ohms  
**Working Voltage** — 335 volts rms  
**Frequency Range** — 0 to 10 GHz  
**Insulation Resistance** — 1000 megohms min.

### Contact Resistance

Outer Contact — 1 milliohms  
 Center Contact —  
   Straight Connectors — 6 milliohms  
   Right-Angle Connectors —  
     12 milliohms

**Dielectric Withstanding Voltage** — 1000 volts rms

**RF Leakage** — -60 dB min., between 2 and 3 GHz

**RF Insertion Loss** —  
 Straight Connectors — 0.25 dB max. at 4 GHz  
 Right-Angle Connectors — 0.50 dB max. at 4 GHz

**Corona Level** — 250 volts min. at 70,000 ft [21 336 m]

### Mechanical Characteristics

**Mating/Unmating** — 10-32 threaded coupling

**Cable Attachment** — Crimp type, both center contact and braid

**Coupling Nut Retention** — 35 lb [156 N] min.

**Cable Retention** — 20 lb [89 N] min., GR-174 cable

**Durability** — 500 cycles per MIL-C-39012

### Environmental Characteristics

**Temperature Range** — -65°C to +85°C

**Vibration** — MIL-STD-1344, Method 2005, Condition IV

**Salt Spray** — MIL-STD-1344, Method 1001, Condition B

**Temperature Cycling** — MIL-STD-1344, Method 1003, Condition A (except low temperature is -65°C)



**SMC Connectors (Continued)**

**Straight Plugs**

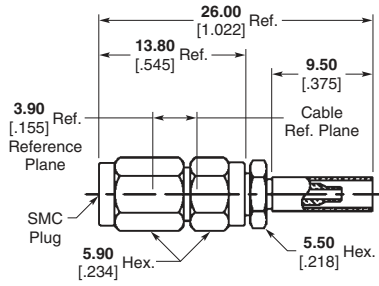

**Part No. 1060220-1  
Crimp**

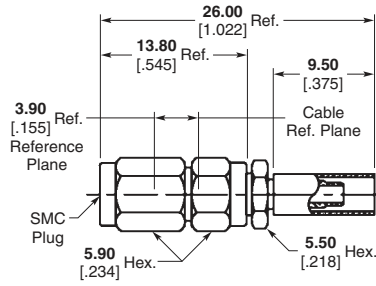

**Part No. 1060221-1  
Crimp**

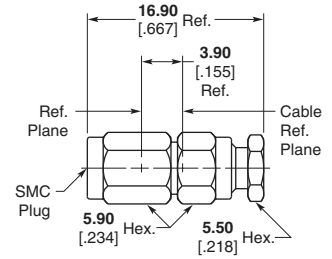

**Part No. 1060163-1  
Clamp**

Cable Attachment	RG/U Cable	Part No.
Crimp	178, 178A, 178B 196, 196A	<b>1060220-1</b>
Crimp	174, 316 188, 188A	<b>1060221-1</b>
Clamp	174, 316 188, 188A	<b>1060163-1</b>

**Straight Jacks**

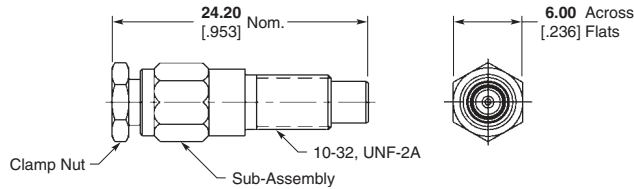

Cable Attachment	RG/U Cable	Part No.
Clamp	174, 316 188, 188A	<b>1311638-1</b>

**Bulkhead Feedthrough Cable Jacks**

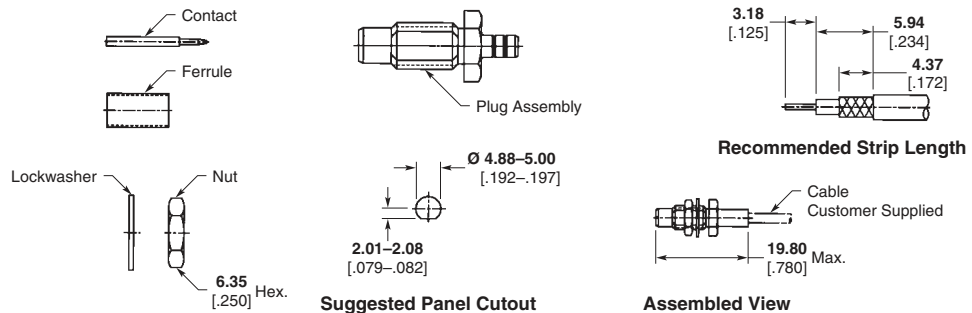

Cable Attachment	RG/U Cable	Part No.
Crimp	174, 316 188, 188A	<b>51751-1</b>

**Note:** Part Numbers are RoHS compliant except: ♦ Indicates non-RoHS compliant.

**SMC Connectors (Continued)**

**Press-In Panel Jacks, Straight Terminal**

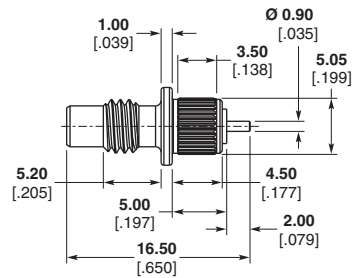

**Part No. 1460470-1**

**Right-Angle Cable Plug**

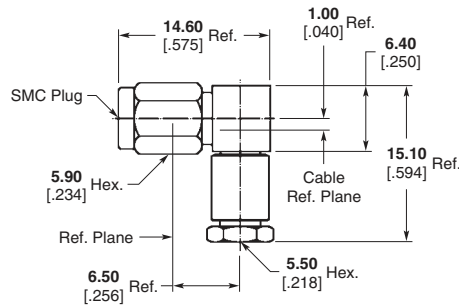

Cable Attachment	RG/U Cable	Part No.
Clamp	174, 316 188, 188A	1060183-1

**PC Board Jack Receptacles**

**Straight**

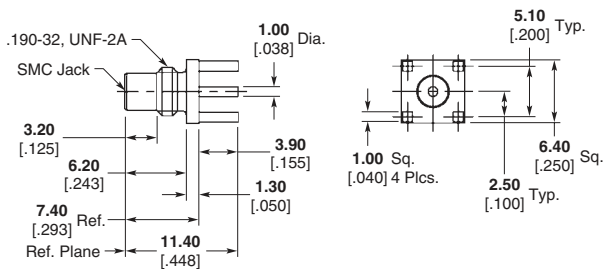

**Part No. 1060256-1**

**Right-Angle**

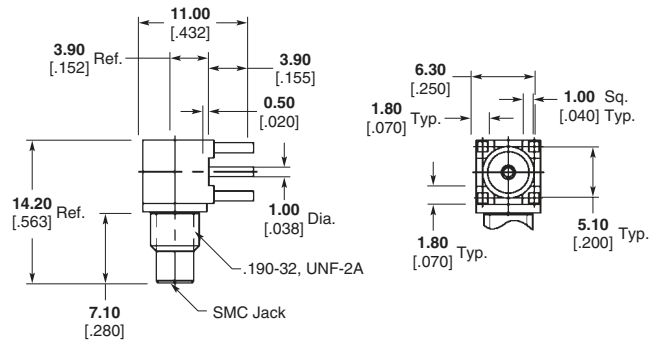

**Part No. 1060259-1**

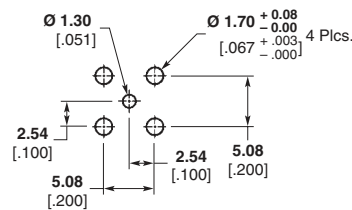

**Recommended PC Board Layout**

**Note:** Part Numbers are RoHS compliant except: ♦ Indicates non-RoHS compliant.

## MCX Connectors

### Product Facts

- Snap-on interface facilitates assembly
- Conforms to CECC interface specifications for MCX
- 30% smaller than SMB connectors
- Surface mount tape and reel for high volume
- 50 and 75 ohm versions available



### Between Series Adapters

For MCX Between Series Adapters, see pages 251-260.

Tyco Electronics MCX microminiature snap-on connectors offer an excellent blend of size, durability and performance for emerging applications in GPS, automotive and wireless communications. MCX connectors are 30% smaller than traditional snap-on SMB connectors, offering greater packaging density and weight reduction. MCX connectors are mechanically robust with beryllium copper spring fingers rated at a minimum of 500 mating cycles. The snap-on interface facilitates assembly, eliminating the need for a threaded connection, and

ensuring full engagement. The forces to engage and disengage have been optimized to ensure ease of mating as well as to prevent damage to PCB solder connections. MCX connectors are designed for broad band performance, DC-6 GHz, and can be utilized for future system upgrades without concerns for performance degradation. Tyco Electronics MCX connectors are fully mateable with standard MCX connectors and conform to the CECC interface specifications.

MCX connectors are available in a broad range of

standard configurations for commercial applications. Tape and reel packaging for MCX surface mount straight and right-angle PCB receptacles is available to facilitate high volume pick and place manufacturing. MCX surface mount connectors are designed to withstand infrared reflow, convection and vapor phase soldering and provide a .254 [.010] standoff for optimal board cleaning. MCX plug and jack PCB receptacles also offer a direct board to board solution providing a nominal 7.11 [0.28] separation.

## MCX Connectors (Continued)

### Specifications

General		CECC 22220 PARA
Materials	—	Brass alloys UNS C36000 (ASTM-B16) or C38500 per QQ-B626, Beryllium copper per ASTM B-196, PTFE fluorocarbon per ASTM-D-1710
Finish	—	Center Contacts: Gold plated (ASTM-B488) over nickel plate (QQ-N-290)
	—	Outer Contacts: Gold plated (ASTM-B488) over nickel plate (OO-N-290)
	—	Housings: Nickel plated (QQ-N-290), tin (ASTM-B488) or Gold plated (ASTM-B488)
	—	All other metal parts shall be furnished so as to provide a connector which meets corrosion requirements of CECC 22220 PARA 4.6.10
Design	—	The design shall be such that the outline and interface dimensions shown in this catalog and the requirements of CECC 22220 PARA are met
Electrical		CECC 22220 PARA (General requirements performance may vary by cable)
Frequency	—	dc - 6 GHz
Nominal Impedance	—	50 ohms
Voltage Rating	—	335 Volts (VRMS Maximum) @ Sea Level
VSWR	4.4.1	1.25:1 Maximum @ 4 GHz
	—	1.35:1 Maximum @ 6 GHz
Insulation Resistance	4.4.4	10,000 Megohms Minimum
Insertion Loss	—	.1dB Maximum/1000 MHz
Dielectric Withstanding Voltage	4.4.5	1000 Volts (VRMS Minimum) @ Sea Level
Contact Resistance		
Center Contact	4.4.2	5.0 Milliohms Maximum
Outer Contact	4.4.3	1.0 Milliohms Maximum
Corona 70,000 ft.	—	250 Volts (VRMS Minimum) @ MHz
RF High Potential @ Sea Level	—	670 Volts (VRMS Minimum) @ MHz
Contact Current	—	1.5 ADC Max
Mechanical		CECC 22220 PARA
Force to Engage	4.5.4	15.5 N [3.4 lbs.] Maximum
Force to Disengage	—	8 – 20 N [1.8 – 4.5 lbs.]
Contact Captivation	4.5.2	Designed to maintain MCX interface when mating 10 N [2.2 lbs.] axial
Connector Durability	4.7.1	500 insertion and withdrawal cycles
Environmental		CECC 22220 PARA
Temperature Rating	—	-65°C + 165°C
Vibration	4.6.3	See CECC 22220
Moisture Resistance	4.6.4	See CECC 22220
Corrosion	4.6.10	See CECC 22220
Thermal Shock	4.6.7	See CECC 22220

Meets or exceeds requirements of CECC 22220. Tyco Electronics has design control and all data contained herein is subject to change without notice. Contact Tyco Electronics for specifications on other connector types.

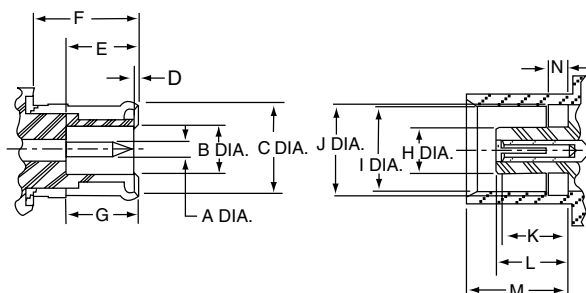

#### Plug

Letter	Minimum	Maximum
A	0.48 [.0189]	0.53 [.0208]
B	2.00 [.0788]	—
C	—	3.8 [.148]
D	0.00 [.000]	0.30 [.0118]
E	2.80 [.111]	3.20 [.125]
F	4.15 [.164]	—
G	2.80 [.111]	—

#### Jack

Letter	Minimum	Maximum
H	—	1.98 [.077]
I	3.42 [.135]	3.48 [.137]
J	3.60 [.142]	3.75 [.147]
K	2.30 [.091]	2.80 [.110]
L	2.60 [.103]	2.80 [.110]
M	4.00 [.158]	4.12 [.162]
N	0.75 [.0296]	0.85 [.0334]

**MCX Connectors (Continued)**

**Straight Cable Plug, Crimp**

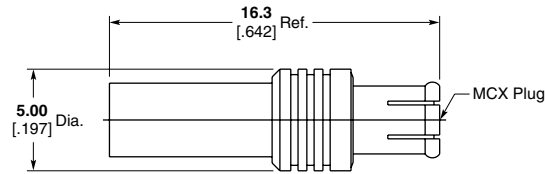

Cable	Plating	Part No.
RG 178/U, 196/U	Nickel	<b>1060869-1</b>
RG 174/U, 188/U, 316/U	Nickel	<b>1060872-1</b>
	Gold	<b>1060871-1</b>
RD-316	Nickel	<b>1060875-1</b>
	Gold	<b>1060875-2</b>

**Note:** For full crimp attachment consult Tyco Electronics at the numbers listed below.

**Right-Angle Cable Plug, Crimp**

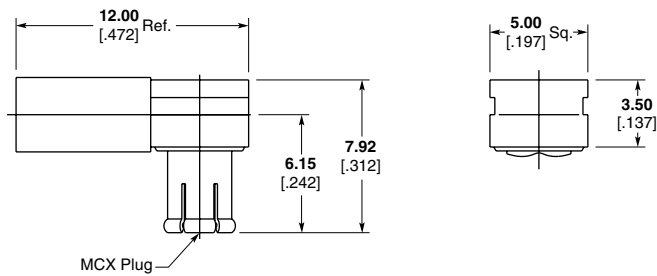
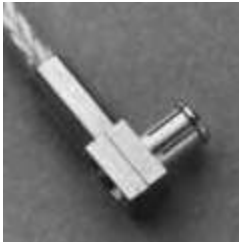

Cable	Plating	Part No.
RG 178/U, 196/U	Nickel	<b>1329293-1</b>
RG 188/U, 316/U RG 179/U, RG 187/U	Nickel	<b>1330723-1</b>
RD-316	Nickel	<b>1363301-1</b>
	Gold	<b>1363301-2</b>

**Straight Cable Terminal, PC Board, Without Center Contact**

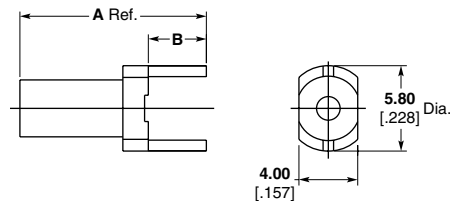
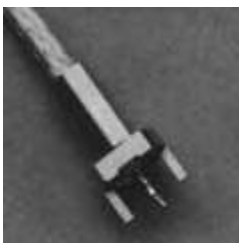

Cable	Dim. A	Dim. B	Plating	Part No.
RG 174/U, 188/U, 316/U	<b>11.76</b>	<b>3.94</b>	Nickel	<b>1060811-1</b>
	.463	.155	Gold	<b>1060811-2</b>
	<b>10.74</b>	<b>2.92</b>	Gold	<b>1060813-2</b>
	.423	.115		

**Note:** Part Numbers are RoHS compliant except: ♦ Indicates non-RoHS compliant.

**MCX Connectors** (Continued)

**Bulkhead Cable Jack**

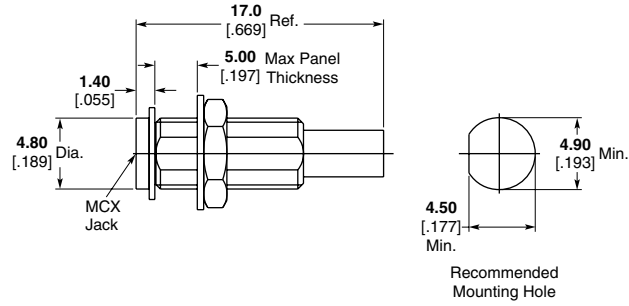

Cable	Plating	Part No.
RG 188/U, RG 316/U	Nickel	<b>1060883-1</b>

**Straight Cable Plug,  
Direct Solder Attachment  
For Semi-Rigid Cable**

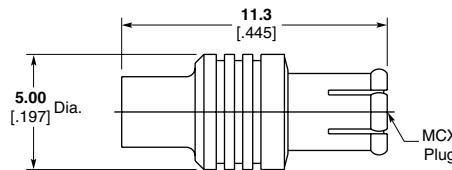

Cable	Plating	Part No.
RG 405/U [0.085]	Gold	<b>1060772-1</b>
.047	Gold	<b>1060772-2</b>

**Straight Cable Jack,  
Direct Solder Attachment  
For Semi-Rigid Cable**

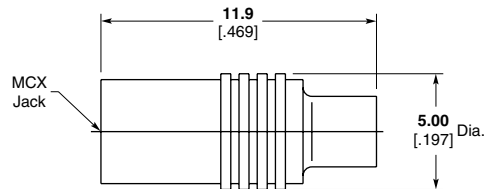

Cable	Plating	Part No.
RG 405/U [0.085]	Gold	<b>1060774-1</b>
.047	Gold	<b>1060774-2</b>

**Note:** Part Numbers are RoHS compliant except: ♦ Indicates non-RoHS compliant.

**MCX Connectors** (Continued)

**Right-Angle Plug Receptacle,  
Direct Solder Attachment  
For Semi-Rigid Cable**

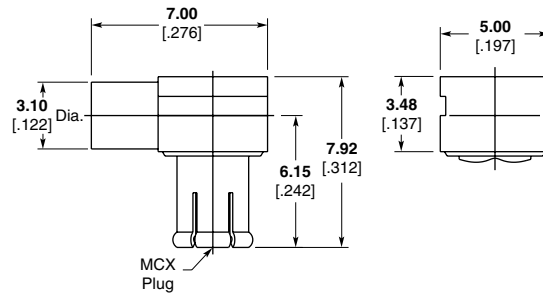

Cable	Plating	Part No.
RG 405/U	Gold	<b>1060787-1</b>

**Vertical Plug Receptacle,  
PC Board**

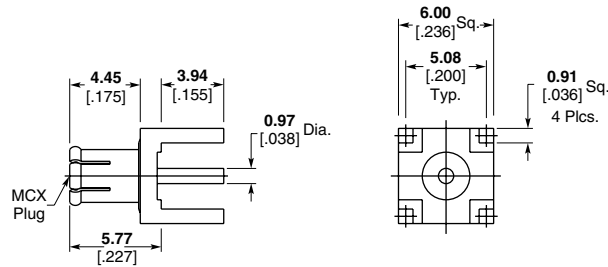

Plating	Part No.
Nickel	<b>1061015-1</b>
Gold	<b>1085221-1</b>

**Vertical Jack Receptacle,  
PC Board**

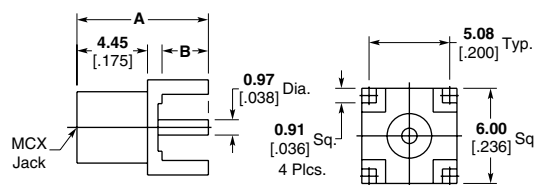
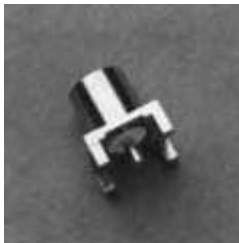

Dim. A	Dim. B	Plating	Part No.
<b>8.28</b>	<b>2.92</b>	Nickel	<b>1060985-1</b>
.326	.115	Gold	<b>1060984-1</b>
<b>9.30</b>	<b>3.94</b>	Nickel	<b>1060989-1</b>
.366	.155	Gold	<b>1330126-1</b>
<b>7.09</b>	<b>1.73</b>	Nickel	<b>1060996-1</b>
.279	.068	Gold	<b>1060995-1</b>

**Note:** Part Numbers are RoHS compliant except: ♦ Indicates non-RoHS compliant.

**MCX Connectors (Continued)**

**Vertical End Launch,  
PC Board**

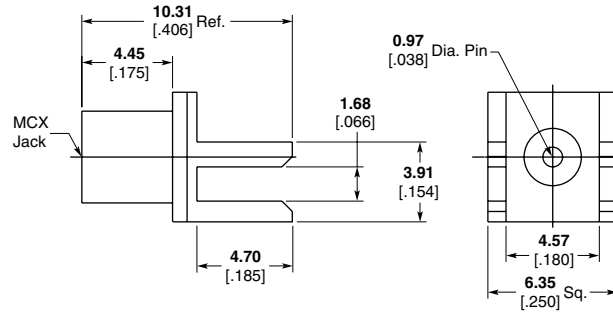

Plating	Part No.
Tin	1061007-1

**Right-Angle Jack  
Receptacle, PC Board**

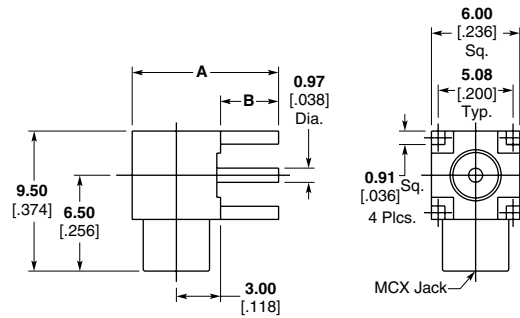
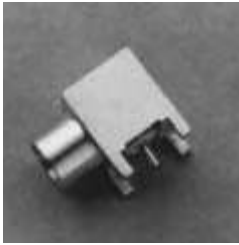

Dim. A	Dim. B	Plating	Part No.
9.93 [0.391]	3.94 [0.155]	Nickel	1061023-1
		Gold	1061022-1
7.72 [0.304]	1.73 [0.068]	Nickel	1061027-1
		Gold	1061026-1
8.92 [0.351]	2.92 [0.115]	Nickel	1061030-1
		Gold	1061029-1

**Jack Receptacle,  
Bulkhead Feedthrough**

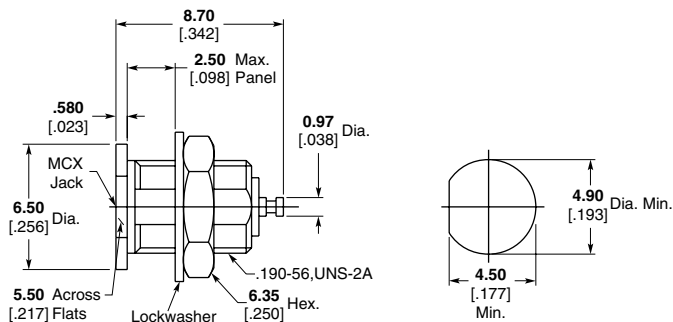

**Recommended Mounting Hole**

Plating	Part No.
Nickel	1060960-1
Gold	1060959-1

**Note:** Part Numbers are RoHS compliant except: ♦ Indicates non-RoHS compliant.



**MCX Connectors** (Continued)

**Vertical Jack Receptacle,  
Surface Mount**

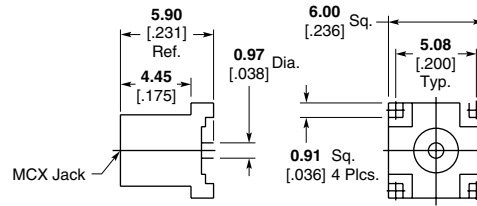
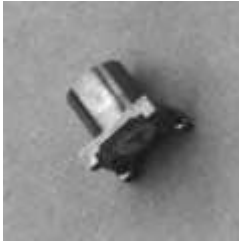

Plating	Part No.
Tin	6061002-1
	6061092-1 <sup>1</sup>

<sup>1</sup>Tape and Reel packaging. 900 connectors per reel (carrier width 16mm, carrier pitch 12mm).

**Right-Angle Jack Receptacle,  
Surface Mount**

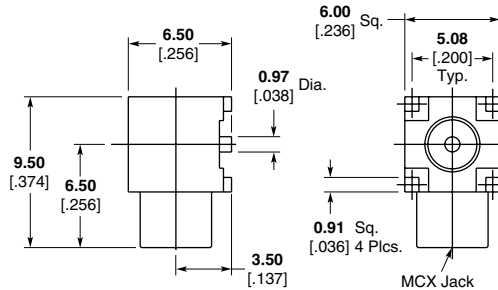

Plating	Part No.
Tin	6061035-1
Tin	6061094-1 <sup>1</sup>

<sup>1</sup>Tape and reel packaging. 750 connectors per reel (carrier width 24mm carrier pitch 12mm).

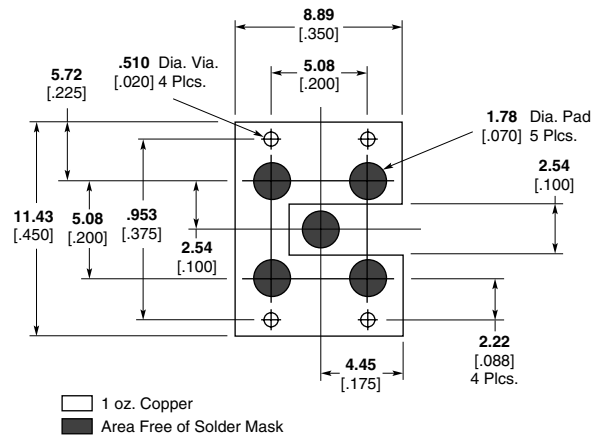

Notes:

1. Printed circuit board material: glass epoxy FR-4 or similar; relative permittivity: 4.8, 1 oz. copper clad both sides.
2. These dimensions valid for 1.58 [0.062] board thickness.
3. Decimal inch equivalents are shown in parentheses for general information only.

**Recommended Mounting Pattern for Microstrip Line**

**Note:** Part Numbers are RoHS compliant except: ♦ Indicates non-RoHS compliant.

**MCX Connectors** (Continued)

**Straight Cable Plug,  
Crimp, 75 Ohm**

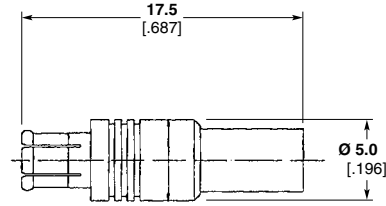

Cable	Plating	Part No.
RG 179/U	Nickel	1362990-1

**Right-Angle Cable Plug,  
Crimp, 75 Ohm**

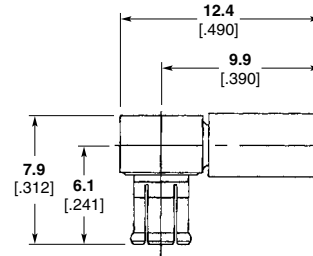

Cable	Plating	Part No.
RG 179/U	Nickel	1362991-1

**Vertical Plug, PC Board,  
75 Ohm**

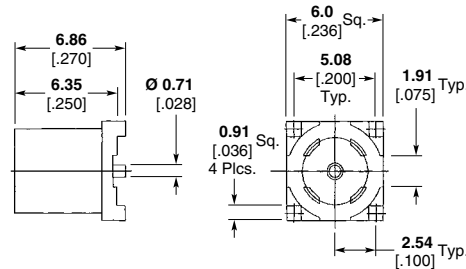

Plating	Part No.
Nickel	1361169-1

**Vertical Jack, PC Board,  
75 Ohm**

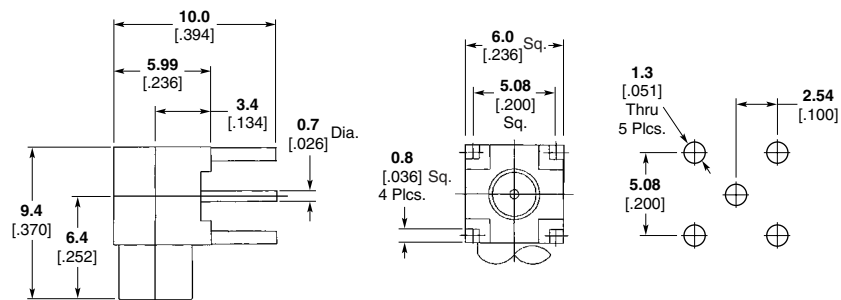

Plating	Part No.
Gold	1363106-1

**Note:** Part Numbers are RoHS compliant except: ♦ Indicates non-RoHS compliant.

## Compression Coax Board-to-Board Connectors

### Board-to-Board RF Connector Series

- Single connector product
- Surface mount technology
- Excellent price-to-performance ratio

### Product Facts

- Single connector design — no mating connectors needed
- Available in four sizes for varied board spacing: 14mm, 10mm, 6.65mm and 4mm
- Large radial and axial misalignment: For positioning both boards and for gap between boards
- Surface Mount Device for standard pick & place compatibility
- Gold plated phosphor bronze and brass contacts, stainless steel springs
- Mating directly on target board
- Easy connection without risk of breaking soldering or connector when mating or unmating
- Low applied material and assembly costs

### Applications

- Modular parallel board-to-board blindmate applications
- Base Station / Sub Station systems
- PDA / PCS / Cellular Handset applications
- Wireless Communications systems (GSM, PCS, WCDMA, UMTS)



### Specifications

**Characteristic Impedance** — 50 Ohms

**Frequency Range** — Up to 6 GHz

**Return Loss** — -20dB min.; up to 2.2 GHz (all misalignments)

**Shielding Effectiveness** — -60 dB min.; up to 2.2 GHz

**Working Voltage** — 125 VAC, 50 Hz (at sea level)

**Dielectric Withstanding Voltage** — 500 VAC, 50 Hz (at sea level)

**Insulation Resistance** — 100 Megohms

**Operating Temperature** — -40 to +125°C

**Mating Force** — 10 N

**Durability** — 25 cycles

**Angle Between Boards** —  $\pm 2^\circ$  max.

**Axial Misalignment** —  $\pm 1.0$ mm from nominal boards stacking height;  $\pm 0.4$ mm,  $\pm 0.3$ mm for shortest models (Part Numbers 619135 and 1658260)

**Radial Misalignment** —  $\pm 0.8$ mm from center line in any direction

**Vibration** — 20 g between 58-500 Hz (Const. amplitude of 1.5 mm between 10-58 Hz)

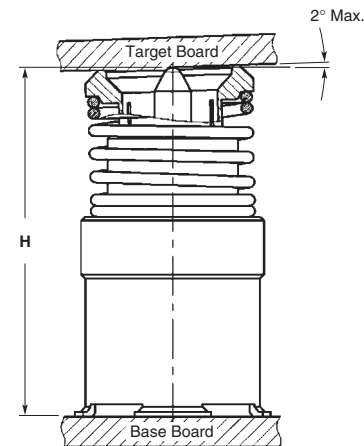

Part Number	Height "H"
619127-1	14 $\pm$ 1.0mm
619134-1	10 $\pm$ 1.0mm
619135-1	6.65 $\pm$ 0.4mm
1658260-1	4 $\pm$ 0.3mm

### Related Product Data

**Internet** — <http://tycoelectronics.com/products/rfcoax>

**Product Specification/Design Objectives** — 108-71060

**Test Report** — 501-90021

**Sample Kit** — 1-1773441-3

**Note:** Part Numbers are RoHS compliant except: ♦ Indicates non-RoHS compliant.

## STAX Coax Connectors

### Product Facts

- Low cost, low height and high performance
- Low insertion loss  
0 to -0.5 dB from 0 to 6 GHz
- VSWR < 1.07 from 0 to 6 GHz
- Wide working range of deflection
- Long term reliability and durability
- Surface mount/pick and place
- Low board separation  
≤ 2.5 mm
- Technology can support board separations ≤ 1.5 mm
- Easily modified free height
- No tooling required for height modifications
- Modified prototype samples within 2 weeks



Tyco Electronics' STAX coax RF connector is the first surface mount RF board-to-board connector on the market that uses elastomeric connector technology to provide an economical means to achieve low board separation while maintaining excellent RF signal integrity between PCBs.

The connector uses laminated sections of conductive and non-conductive silicone that are tuned to provide a 50 ohm

impedance line between mated substrates. The single piece construction of the STAX coax RF connector eliminates some of the signal anomalies normally associated with mated pairs of metal contact coax connectors. The dimensional relationship of the inner and outer conductor is consistently maintained throughout the connector.

With its metal holder, the STAX coax RF connector can be surface mount

soldered to the PCB. An additional metal SMT holder aligns the connector to the mating PCB. If adequate PCB alignment is already maintained by other means, the STAX RF connector may not need the additional mating receptacle and can become a blindmating connector. This has an additional advantage in space constrained mobile applications where very fine-pitch board-to-board connectors are also used.

### Related Product Data

**Internet** — [www.elastomerictech.com](http://www.elastomerictech.com)  
[www.tycoelectronics.com](http://www.tycoelectronics.com)

### Elastomeric Technologies Applications Engineering —

Phone: 1-800-989-STAX ext. 4453

Fax: 1-215-784-4522

E-mail: [ETIapplicationseng@tycoelectronics.com](mailto:ETIapplicationseng@tycoelectronics.com)

### Technical Documents —

Qualification Test Report — T R 368

RF Performance Report — 00266

### Electrical Characteristics

**Contact Resistance** — < 50 mΩ

**Insulation Resistance** — 10<sup>12</sup> Ω min.

**Dielectric Withstanding Voltage (without breakdown or arcing)** — 1000 Volt

### Physical Characteristics

**Board Separation** — 2.5 mm ± 0.2 (std. part)

**PCB Board Area** — 4.0 mm dia.

**Typical Clamping Force** — See chart

### Environmental Characteristics

**Operating Temperature** — -40°C to +125°C

**Moisture** — 0 to 100% RH

**STAX Coax Connectors** (Continued)

Description	Part Number
STAX SMT Coax Connector Assembly: Consists of STAX Coax elastomer in round SMT holder	619229-1
Mating SMT Target Holder: Controls alignment between PCBs	619238-2
STAX Coax RF Elastomer only: Used with customer furnished holder	1442004-1

**Part Number 619229-1**  
**SMT STAX Coaxial**  
**Connector Assembly**

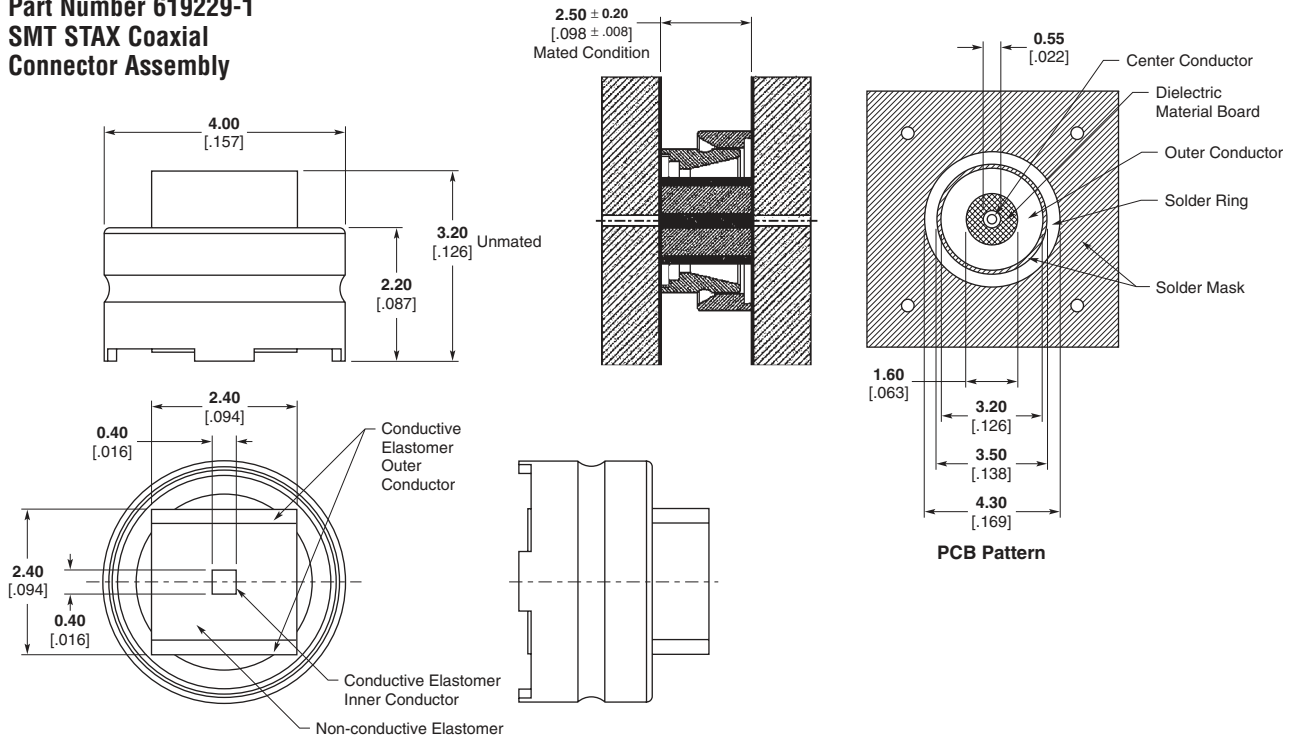

**Part Number 619238-2**  
**SMT Mating Target Holder**

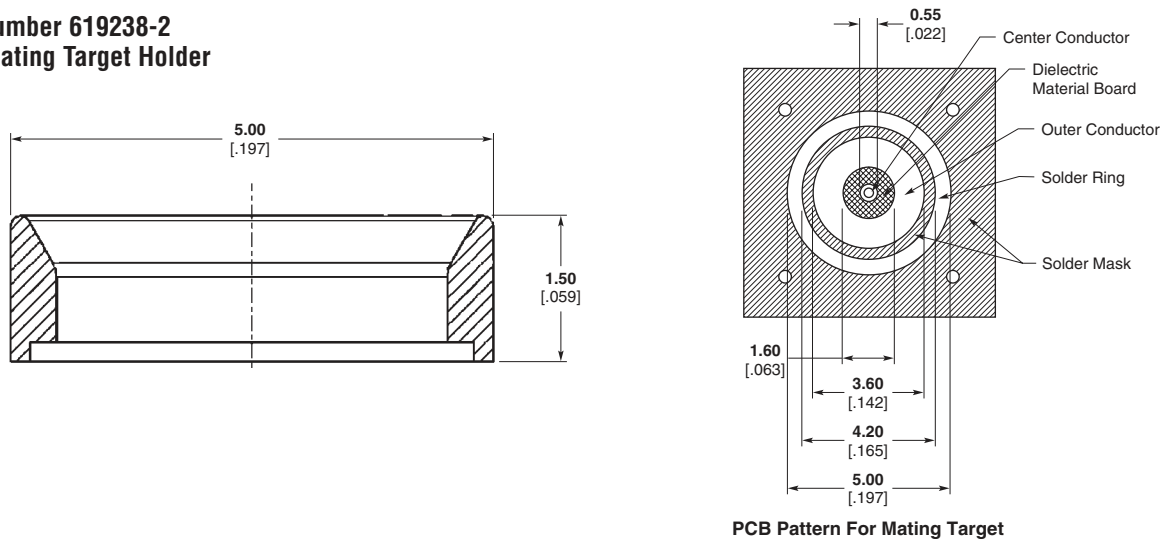

**Note:** Part Numbers are RoHS compliant except: ♦ Indicates non-RoHS compliant.

**SMT/QuickGrip Connectors**

**Product Facts**

- Solderless Cable Termination
- 3.0 [.118] Mated Height
- Excellent Cable Retention
- Usable With Flexible and Semi-Rigid Micro-Coaxial Cables
- Tape and Reel Packaging

Tyco Electronics revolutionary SMT/QuickGrip product line is designed to meet the growing demand for a reliable, low cost system for direct termination of coax to a printed circuit board (PCB). SMT/QuickGrip technology eliminates the requirement to connectorize the coaxial cable, reducing assembly times and, therefore, cost. The SMT/QuickGrip surface mount device occupies less PCB area than conventional through hole coaxial connectors. An innovative microstrip mounting pattern and cable receptacle design ensures excellent grounding and PCB retention. The SMT/QuickGrip cable termination system stands a mere 3.0 [.118] off the board when mated, allowing for closer pitch/spacing when designing a

system. The SMT/QuickGrip design provides optimal cable retention for applications where shock, vibration, and/or cable flexure may be encountered. This unique RF design accepts both flexible and semi-rigid micro-coaxial cables while delivering exceptional RF performance up to 3GHz.

These features make this system extremely versatile for design engineers and offer a reliable, cost effective alternative to direct soldering of cable to the PCB. The cable is inserted into the device by means of a simple self-aligning hand tool, eliminating the requirement for skilled personnel. This system removes the possibility of damaged PCBs and cables which are common quality issues associated with direct solder, while providing superior RF performance. The SMT/QuickGrip accommodates multiple cable insertions allowing easy replacement of cables for repairs. This receptacle is designed for high volume assembly using surface mount technology and is available in tape and reel packaging for pick and place board assembly. Pre-stripped cables and inter-

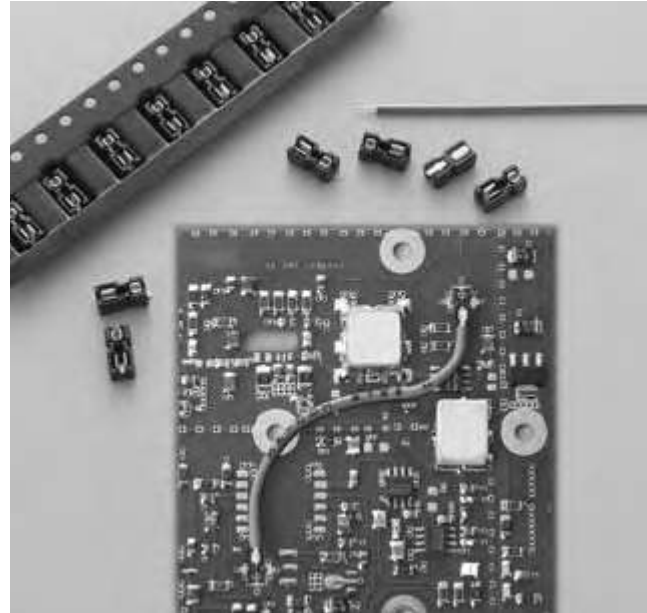

series cable pigtails are available as turnkey solutions for your application needs (i.e.: for use in multi-board applications, for connecting antennas to the PCB, or point to point transmission on the same PCB).

The SMT/QuickGrip cable termination system is ideal for wireless surface mount applications in handsets, pagers and personal digital assistants (PDA). The SMT/QuickGrip

mechanical and electrical performance, coupled with its ease of use, ensure it to be a high quality, reliable solution for current and future interconnect needs. Tyco Electronics is an ISO9001 certified manufacturer and maintains an SPC controlled manufacturing environment. Please call your local Sales or Distribution office for additional information and qualification samples today.

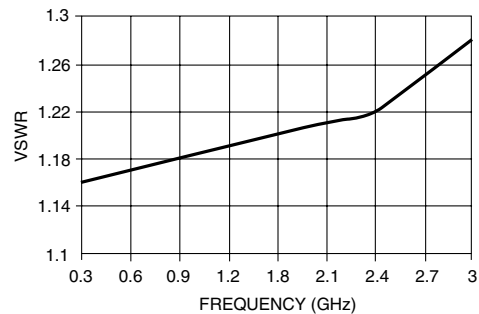
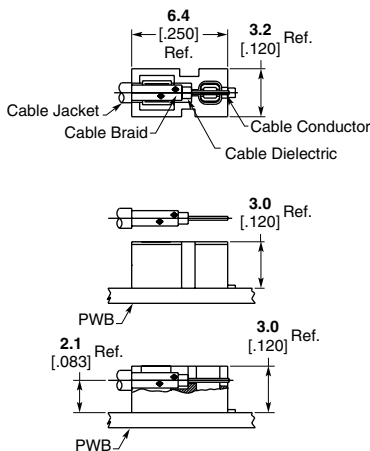

Typical VSWR using SMT/QuickGrip with Omni-Flex 200 Cable

Omni-Flex 200 cable is a Tyco Electronics specified cable.



**SMT/QuickGrip Connectors** (Continued)

**Specifications**
**General**
**Materials**

Housing:	Polyphenylene Sulfide (PPS)
Contacts:	Copper Alloy

**Finishes**

Contacts:	Gold Plate over Nickel
-----------	------------------------

**Electrical**

Frequency Range:	DC - 3GHz
Impedance:	Usable with 50 & 75 Ohm systems
Insertion Loss:	.08 $\sqrt{f}$ GHz
DWV:	750 VRMs
VSWR:	1.3:1 @ 3GHz (Omni-Flex 200 and .047 [.002] Semi-Rigid) 1.4:1 @ 3GHz (.034 [.001] Semi-Rigid)

**Mechanical**

Connector Durability:	5 mating cycles min. (receptacle only)	
Tape and Reel Packaging:	16 [.629] per EIA-481	
Force to Disengage by Cam-Out (grams):	Omni-Flex 200 Cable -	543 typical
	.034 [.001] Semi-Rigid -	852 typical
	.047 [.002] Semi-Rigid -	1066 typical

**Environmental**

Temperature Rating:	-40°C(-40°F) to 125°C(257°F) when mated with Omni-Flex 200 Cable
Resistance to Solder Heat:	Infrared, convection, and vapor phase solderable (receptacle only). Maximum reflow time/temperature not to exceed 260°C for 3 minutes.

**Cable Information**

Materials:	Omni-Flex 200 Cable
Jacket:	FEP Flexible Cable (200°C)
Shield:	Fluorinated Ethylene Propylene
Dielectric:	Silver plated copper wire, 44 AWG, 90% min. coverage
Center Conductor:	PTFE (Polytetrafluoroethylene)
Minimum Bend Radius:	Silver Plated Copper Clad Steel, 30 AWG
Insertion Loss (PVC and FEP cable only):	6.35 [.250]
Center Conductor Resistance:	1.3dB/m, 0.4 dB/ft. @ 500 MHz 2.0dB/m, 0.5 dB/ft. @ 1 GHz 3.0dB/m, 0.9 dB/ft. @ 2 GHz
	.26 Ohms per foot average

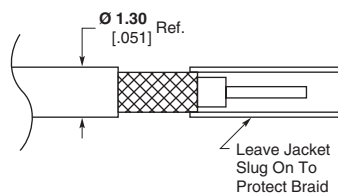
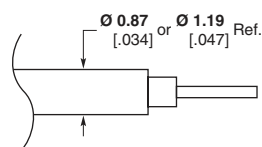
**Strip Dimensions**
**Tyco Electronics  
Omni-Flex 200 Cable  
Part Number 1407578-1**

**Semi-Rigid Cable  
(.034 and .047)**

Omni-Flex 200 cable is a Tyco Electronics specified cable.

**Note:** Part Numbers are RoHS compliant except: ♦ Indicates non-RoHS compliant.

**SMT/QuickGrip Connectors** (Continued)

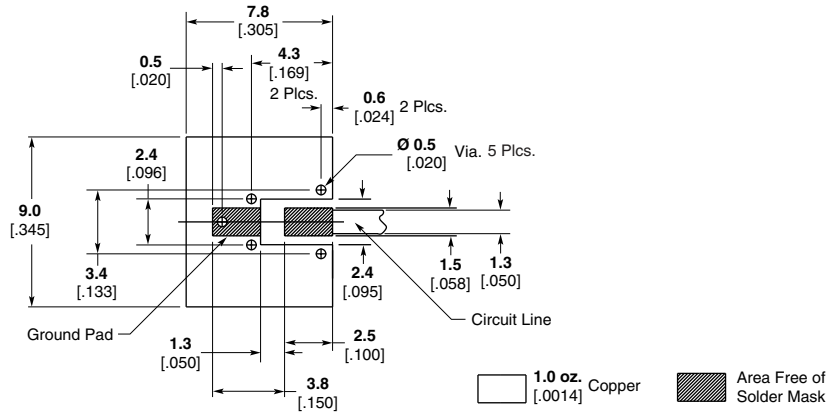
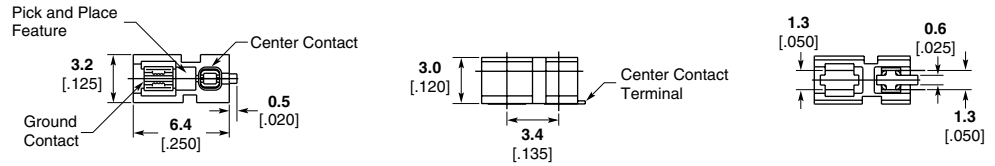
**PC Board Mount Receptacle**



**Recommended Mounting Pattern for Microstrip Line**

Description	Part No.
Bulk Packaged 100/bag	<b>1085456-1</b>
700 Piece Reel	<b>1086008-1</b>
2000 Piece Reel	<b>1086009-1</b>

1. Printed wiring board material: glass epoxy FR-4 or similar, relative permittivity: 4.8, 1 oz. copper clad both sides.
2. These dimensions valid for 1.6 [.062] board thickness.

**Cable Insertion Tool**



Part No.
<b>1088313-1</b>

**Note:** Part Numbers are RoHS compliant except: ♦ Indicates non-RoHS compliant.



**SMT/QuickGrip Connectors** (Continued)

**Inter-Series Cable Assemblies**



**SMA Straight Plug**

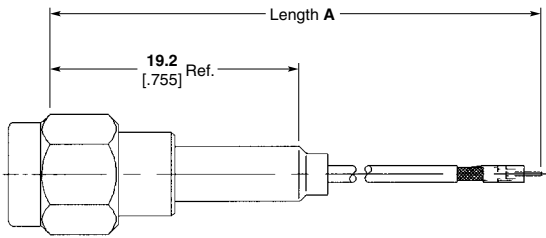

Cable	Assembly Length (A)	Part No.
Omni-Flex 200	100 [4]	<b>1329174-1</b>
	200 [8]	<b>1329174-2</b>
	305 [12]	<b>1310432-1</b>

**Note:**

1. Cable length tolerances: Length 'A' mm [In], Tolerance mm [In],  
 50 to 100 [3.94], ± 3 [± .12], 101 to 500 [3.98 to 19.69], ± 5 [± .20],  
 Over 500 [19.69], ± 10 [± .39]

**SMA Bulkhead Jack**

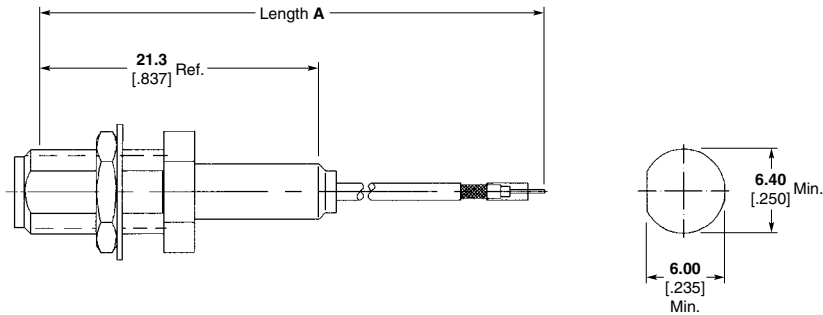

**Recommended Mounting Hole**

Cable	Assembly Length (A)	Part No.
Omni-Flex 200	100 [4]	<b>1329175-1</b>
	200 [8]	<b>1329175-2</b>
	305 [12]	<b>1329175-3</b>

**Note:**

1. Cable length tolerances: Length 'A' mm [In], Tolerance mm [In],  
 50 to 100 [3.94], ± 3 [± .12], 101 to 500 [3.98 to 19.69], ± 5 [± .20],  
 Over 500 [19.69], ± 10 [± .39]

Omni-Flex 200 cable is a Tyco Electronics specified cable.

**Note:** Part Numbers are RoHS compliant except: ♦ Indicates non-RoHS compliant.

**SMT/QuickGrip Connectors** (Continued)

**Inter-Series Cable Assemblies** (Continued)

**SMB Bulkhead Jack**

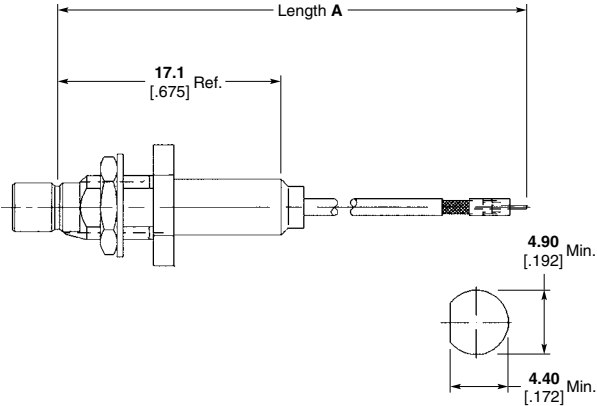

**Recommended Mounting Hole**

Cable	Assembly Length (A)	Part No.
Omni-Flex 200	100 [4]	<b>1408050-4</b>
	200 [8]	<b>1408050-5</b>
	305 [12]	<b>1408050-6</b>

**Note:**

1. Cable length tolerances: Length 'A' mm [In], Tolerance mm [In],  
50 to 100 [3.94], ± 3 [± .12], 101 to 500 [3.98 to 19.69], ± 5 [± .20],  
Over 500 [19.69], ± 10 [± .39]

**SMB Right-Angle Plug**

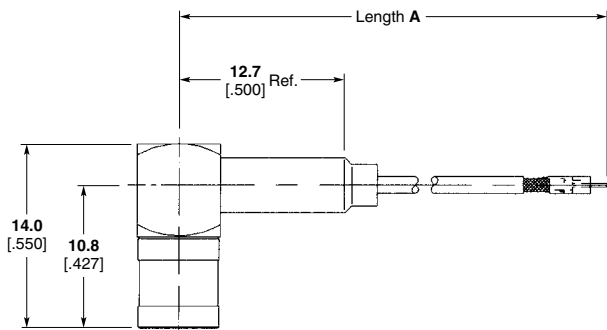

Cable	Assembly Length (A)	Part No.
Omni-Flex 200	100 [4]	<b>1255378-4</b>
	200 [8]	<b>1255378-5</b>
	305 [12]	<b>1255378-6</b>

**Note:**

1. Cable length tolerances: Length 'A' mm [In], Tolerance mm [In],  
50 to 100 [3.94], ± 3 [± .12], 101 to 500 [3.98 to 19.69], ± 5 [± .20],  
Over 500 [19.69], ± 10 [± .39]

**MCX Bulkhead Jack**

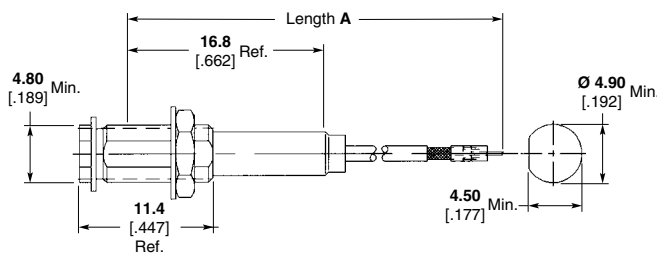

**Recommended Mounting Hole**

Cable	Assembly Length (A)	Part No.
Omni-Flex 200	100 [4]	<b>1408051-4</b>
	200 [8]	<b>1408051-5</b>
	305 [12]	<b>1408051-6</b>

**Note:**

1. Cable length tolerances: Length 'A' mm [In], Tolerance mm [In],  
50 to 100 [3.94], ± 3 [± .12], 101 to 500 [3.98 to 19.69], ± 5 [± .20],  
Over 500 [19.69], ± 10 [± .39]

**MCX Right-Angle Plug**

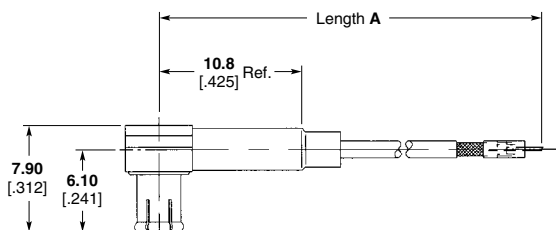

Cable	Assembly Length (A)	Part No.
Omni-Flex 200	100 [4]	<b>1330401-4</b>
	200 [8]	<b>1330401-5</b>
	305 [12]	<b>1330401-6</b>

**Note:**

1. Cable length tolerances: Length 'A' mm [In], Tolerance mm [In],  
50 to 100 [3.94], ± 3 [± .12], 101 to 500 [3.98 to 19.69], ± 5 [± .20],  
Over 500 [19.69], ± 10 [± .39]

Omni-Flex 200 cable is a Tyco Electronics specified cable.

**Note:** Part Numbers are RoHS compliant except: ♦ Indicates non-RoHS compliant.

## SSMT Surface Mount Interconnect System

### Microminiature Surface Mount RF Connectors

#### Product Facts

- 3.0 [.118] mated height
- Excellent interface retention
- Flexible micro-coax cable
- 360 degree mated rotation
- Tape and Reel packaging available

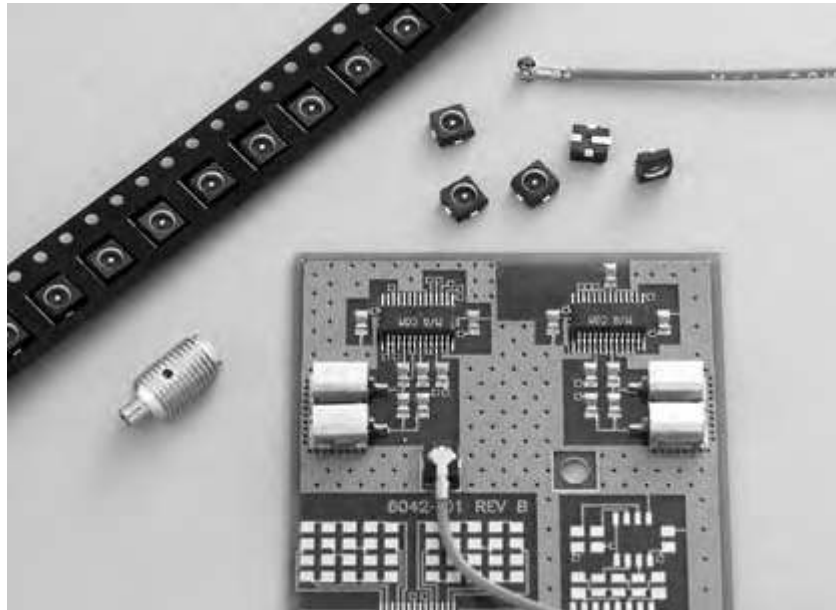

The Tyco Electronics SSMT surface mount Interconnect System is designed to provide superior electrical and mechanical performance for wireless communication applications. The SSMT system occupies less printed circuit board (PCB) real estate than conventional through hole coaxial connectors. An innovative microstrip mounting pattern and plug receptacle design ensure reliable grounding and PCB retention characteristics. The SSMT Interconnect System allows closer pitch/spacing, standing 3.0 [.118] (fully mated height) off the board. The mated SSMT interface allows 360 degrees of rotation providing maximum PCB design flexibility. It has been designed to provide optimal retention for

applications where shock, vibration or cable flexure may be encountered. Force to disengage by cable load (cam-out) exceeds 300 grams.

The SSMT system is designed to provide the performance of much larger industry standard connectors. The SSMT Interconnect System consistently achieves broad band electrical performance through 6 GHz with a maximum VSWR of 1.20:1 at 2 GHz. This broad band performance establishes a reliable interface that can be utilized for future system upgrades without concern for performance degradation.

The SSMT utilizes a common plug receptacle, part number 1251802-1, which is designed for high volume

assembly using surface mount technology and is available in tape and reel packaging for automatic pick and place board assembly. The mating cable jack is available terminated to a highly flexible micro-coax cable as either a pigtail, jumper or standard interseries connector assembly to meet your needs.

The SSMT Interconnect System can be manually mated, facilitating high volume assembly and eliminating the need for special engagement tooling. The SSMT interface design aligns the center contacts prior to full mating to ensure a robust mechanical engagement. Interface durability is rated at 100 mating cycles.

## SSMT Surface Mount Interconnect System (Continued)

### Specifications

#### General

##### Materials

SMT Plug	Housing: Contacts:	Polyphenylene Sulfide (PPS) Copper Alloy
SSMT Cable Jack	Outer Contact: Inner Contact: Dielectric:	Beryllium Copper Beryllium Copper Polypropylene, GF
Finish	Plug and cable jack - Contacts: Gold plate over nickel plate	

#### Electrical

Frequency	dc - 6 GHz
Nominal Impedance	50 Ohms
Voltage Rating	250 Volts (VRMS Maximum) @ Sea Level
VSWR (Mated Pair)	1.20:1 Maximum @ 2 GHz 1.40:1 Maximum @ 6 GHz
Insulation Resistance	5000 Megohms Minimum
Dielectric Withstanding Voltage	500 Volts (VRMS Minimum) @ Sea Level
Contact Resistance (Connectors Only)	
Center Contact	15 milliohms Maximum
Outer Contact	10 milliohms Maximum
Insertion Loss (Connectors Only)	.15dB Max. @ 6 GHz

#### Mechanical

Connector Durability	100 mating cycles
Tape/Reel Packaging (Plug)	12mm per EIA-481
Force to Engage	5.5 lbs. Max. (3.5 lbs. typ.)
Force to Disengage	(2.0 lbs. typ.) 4.0 lbs. Max. (2.0 lbs. typ.)
Force to Disengage by Cable Load (camout)	300 Grams Min. (800 Grams typ. initial mate)

#### Environmental

Temperature Rating (Mated Pair)	-40°C (-40°F) to +125°C (257°F)
Resistance to Solder Heat	Infrared, convection and vapor phase solderable (plug only). Maximum reflow time/temperature not to exceed 260°C for 3 minutes.

#### Cable Specifications

##### Materials

Jacket:	FEP (polytetrafluoroethylene)
Shield:	Silver plated copper wire, 44 AWG, 90% min. coverage
Dielectric:	PTFE ( polytetrafluoroethylene)
Center Conductor:	Silver plated copper clad steel, 30 AWG
Minimum Bend Radius	6.35mm (.250 inch)
Insertion Loss (Cable Only)	0.5 dB/ft., 2.0 dB/m @ 1 GHz 0.9 dB/ft., 3.0 dB/m @ 2 GHz
Center Conductor Resistance	.25 Ohms per foot average. 819 milliohm/meter Nom.; 250 milliohm/Ft. Nom.

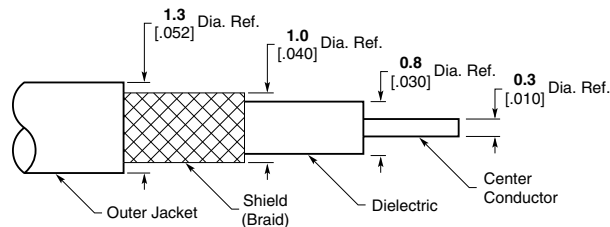

**SSMT Surface Mount Interconnect System (Continued)**

**Straight SMT PCB Mount Plug Receptacle**

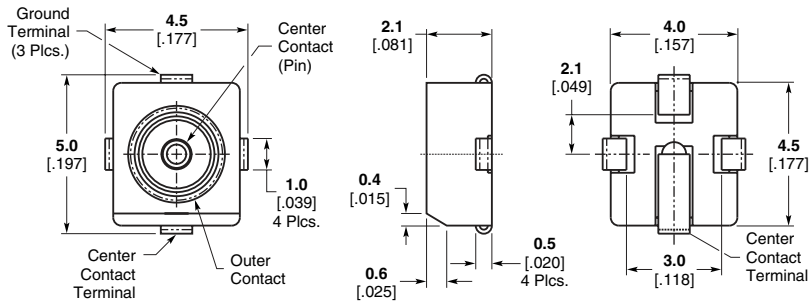

Packaging	Quantity	Part No.
Bulk	Multiple of 100	1251802-1
178 7.0 Dia. Taping	800 pcs/reel	1083946-1
330 13.3 Dia. Taping	3000 pcs/reel	1055689-1

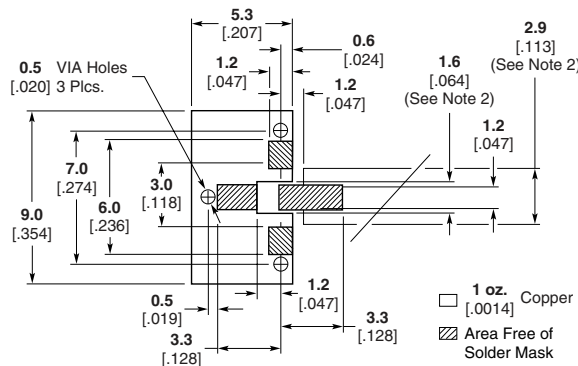

Notes:

1. Printed wiring board material: glass epoxy, FR-4 or similar, relative permittivity: 4.8, 1 oz. copper clad both sides.
2. These dimensions valid for 1.6 [0.62] board thickness.

Recommended Mounting Pattern for Microstrip Line

**Right-Angle Jack to Jack Cable Assembly**

Assembly Length (A)	Part No.
100 [4.0]	1064524-1
200 [8.0]	1064530-1
305 [12.0]	1064533-1

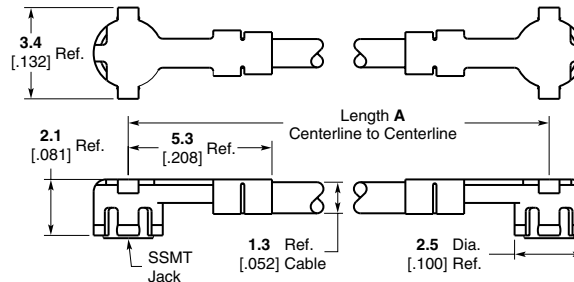

Notes:

1. Consult Tyco Electronics for non-standard cable lengths.  
Length A Tolerances.  

Length A	Tolerance
50 To 100 [3.94]	± 3 [± .12]
101 To 500 [3.98 to 19.69]	± 5 [± .20]
Over 500 [19.69]	± 10 [± .39]
2. Connector centerlines align ± 30° as shown for lengths of 165 [6.5] or less. Cable assemblies over 165 [6.5] have randomly aligned connectors.

**Note:** Part Numbers are RoHS compliant except: ♦ Indicates non-RoHS compliant.

**SSMT Surface Mount Interconnect System** (Continued)

**Right-Angle Jack to Jack  
Cable Assembly  
(180° Offset)**

Assembly Length (A)	Part No.
100 [4.0]	1082845-1

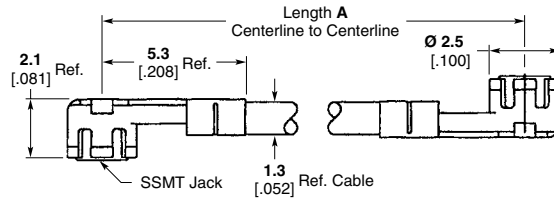

Notes:

1. Consult Tyco Electronics for non-standard cable lengths.  
Cable length tolerance:

Length A Tolerances.

Length A	Tolerance
50 To 100 [3.94]	± 3 [± .12]
101 To 500 [3.98 to 19.69]	± 5 [± .20]
Over 500 [19.69]	± 10 [± .39]

2. To avoid damaging the cable, minimize time at temperature while soldering and/or applying heat to unterminated end of cable.

**Right-Angle Jack Cable  
Pigtail**

Assembly Length (A)	Part No.
100 [4.0]	1064535-1
200 [8.0]	1064538-1
305 [12.0]	1064540-1
510 [20.0]	1064542-1

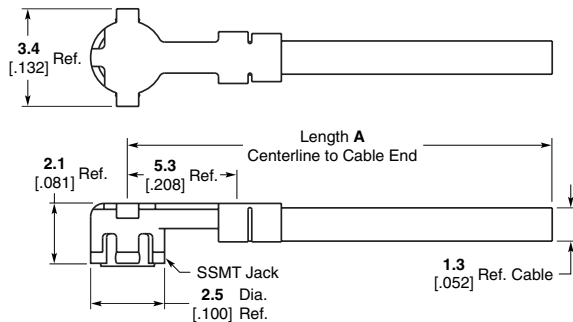

Notes:

1. Consult Tyco Electronics for non-standard cable lengths.  
Cable length tolerance:

Length A Tolerances.

Length A	Tolerance
50 To 100 [3.94]	± 3 [± .12]
101 To 500 [3.98 to 19.69]	± 5 [± .20]
Over 500 [19.69]	± 10 [± .39]

2. To avoid damaging the cable, minimize time at temperature while soldering and/or applying heat to unterminated end of cable.

**Note:** Part Numbers are RoHS compliant except: ♦ Indicates non-RoHS compliant.

**SSMT Surface Mount Interconnect System** (Continued)

**Inter-Series Cable Assemblies**



Notes:

1. Consult Tyco Electronics for non-standard cable lengths:  
Length A Tolerances.

Length A	Tolerance
50 To 100 (3.94)	± 3 (± .12)
101 To 500 (3.98 to 19.69)	± 5 (± .20)
Over 500 (19.69)	± 10 (± .39)

2. Connectors are randomly aligned unless otherwise noted.

**SMA Straight Plug**

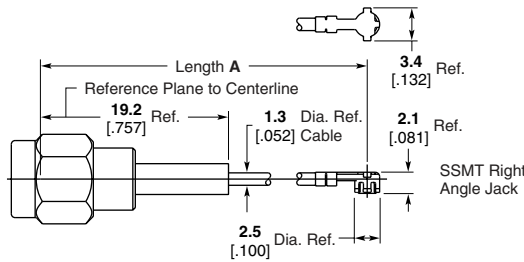

Assembly Length (A)	Part No.
100 [4.0]	1064543-1
200 [8.0]	1064552-1
305 [12.0]	1064560-1

Note:  
1064552-1 recommended for customer system verification.

**SMA Bulkhead Jack**

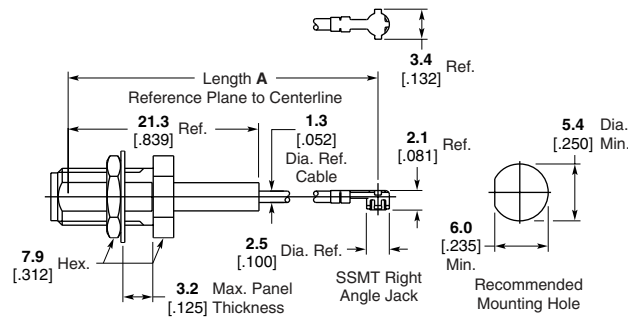

Assembly Length (A)	Part No.
100 [4.0]	1064544-1
200 [8.0]	1064553-1
305 [12.0]	1064561-1

**SMB Bulkhead Jack**

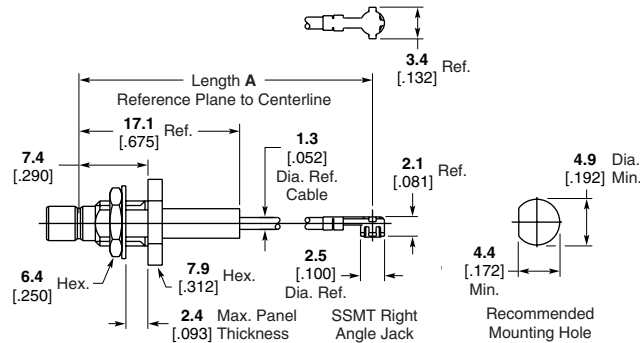

Assembly Length (A)	Part No.
100 [4.0]	1064546-1
200 [8.0]	1064555-1
305 [12.0]	1064563-1

**Note:** Part Numbers are RoHS compliant except: ♦ Indicates non-RoHS compliant.

**SSMT Surface Mount Interconnect System** (Continued)

**Inter-Series Cable Assemblies** (Continued)

**MCX Bulkhead Jack**

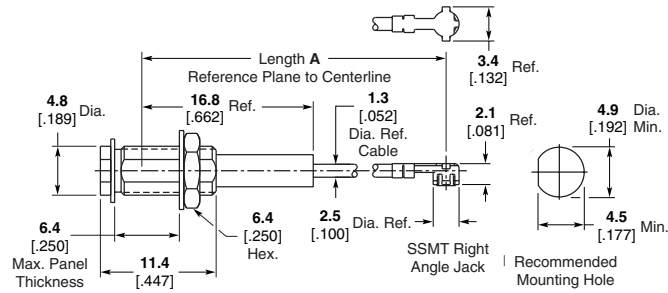

Assembly Length (A)	Part No.
100 [4.0]	1064549-1
200 [8.0]	1064558-1
305 [12.0]	1064566-1

**MCX Right-Angle Plug**

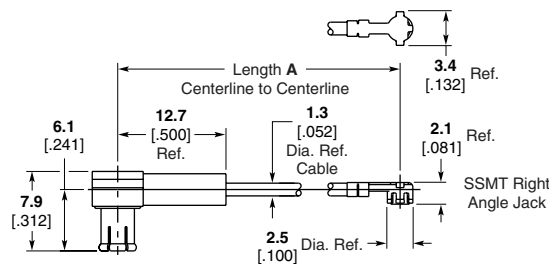

Assembly Length (A)	Part No.
100 [4.0]	1064550-1
200 [8.0]	1064559-1
305 [12.0]	1064567-1

**SSMT Disengagement Tool**

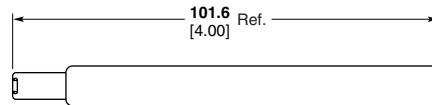

Part No.
1221286-1

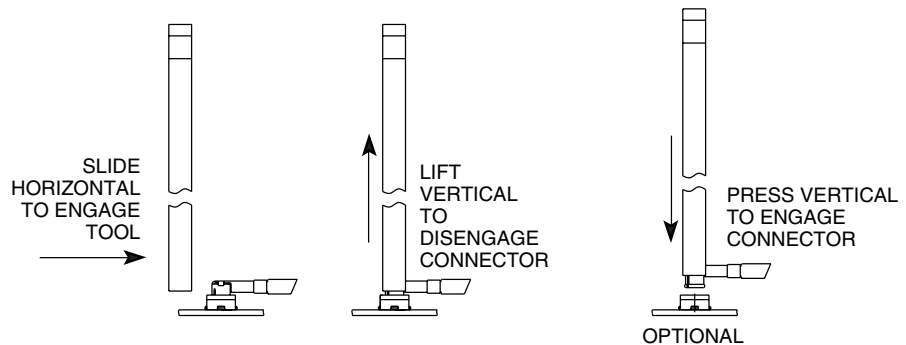

**Use of Engagement/Disengagement Tool**

Note: The SSMT disengagement tool can be utilized as an optional engagement tool versus manual hand installation.

**SSMT to SMA Between Series Adapters**

**SSMT Plug to SMA Jack Adapter**

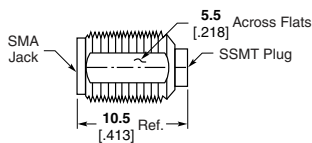

Part No. 1055696-1

**SSMT Plug to SMA Plug Adapter**

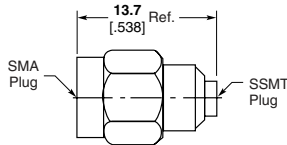

Part No. 1055695-1

**SSMT Jack to SMA Jack Adapter**

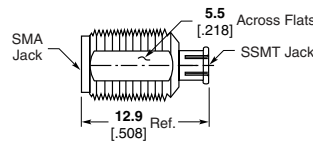

Part No. 1055694-1

**SSMT Jack to SMA Plug**

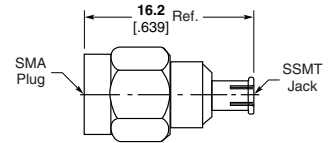

Part No. 1055697-1

**Note:** Part Numbers are RoHS compliant except: ♦ Indicates non-RoHS compliant.



## MMCX Microminiature Snap-On Connector Series

### Product Facts

- Snap-on interface facilitates assembly
- 35% smaller than MCX Series
- Designed for space saving applications up to 6 GHz
- Conforms to CECC Specifications
- Surface mount tape and reel for high volume

Tyco Electronics' micro-miniature snap-on connectors offer an excellent blend of size, durability and performance for emerging applications in GPS, PCS, automotive and wireless communications. An extension of the popular MCX series, MMCX connectors are 35% smaller, offering even greater packaging density and weight reduction. MMCX connectors are rated to 500 mating cycles. The snap-on interface facilitates assembly, eliminating the need for a threaded connection, and ensuring full engagement. The forces to engage and disengage have been optimized to ensure ease of mating as



well as to prevent damage to PCB solder connections. MMCX connectors are designed for broadband performance, DC-6 GHz, and can be utilized for future system upgrades without concerns for performance degradation. The non-slotted outer contact provides for minimal RF leakage. MMCX surface mount connectors are designed to withstand infrared reflow, convection and vapor phase soldering.

Tyco Electronics MMCX connectors are fully mateable with competitive MMCX product and conforms to the CECC interface specifications. They are available in a broad range of standard

configurations, including PCB and panel mount, flexible and semi-rigid cable. Tape and reel packaging is available on surface mount product to facilitate high volume manufacturing. Other options can be reviewed as well, including additional cable sizes, and adapters.

The MMCX connector series is a cost effective solution for the challenging demands of today's commercial marketplace. It offers one of the smallest conventional crimp terminations without special tooling. Call your local sales office or authorized distributor for additional information or samples of the MMCX connector series.

### Material and Finish

**Shells** — Brass  
**Bodies** — Brass, plated gold  
**Center Contacts** —  
 (Male) — Brass, plated gold  
 (Female) — Beryllium Copper, plated gold  
**Dielectrics** — PTFE

### Electrical Characteristics in accordance with CECC 22000

**Frequency** — dc – 6 GHz  
**Nominal Impedance** — 50 ohms  
**Voltage Rating** — 170 Volts (VRMS Max.) @ Sea Level  
**VSWR** — 1.25 : 1 Max. @ 6 GHz  
**Insulation Resistance** — 1,000 Megohms Min.

**Dielectric Withstanding Voltage** — 500 Volts (VRMS Max.) @ Sea Level

**RF Leakage** — -60 dB Min. @ 2.5 GHz

**Contact Resistance** —  
 Center Contact — 5 milliohms max.  
 Outer Contact — 1 milliohm max.

### Mechanical Characteristics in accordance with CECC 22000

**Connector Durability** — 500 mating cycles  
**Force to Engage** — 18 Newtons Max.  
**Force to Disengage** — 6 Newtons Max.  
**Center Contact Retention** — 10 Newtons Min.  
**Cable Retention** —  
 Axial — 45 Newtons Min.  
 Rotational — 0.05 N-m Min.

### Environmental Characteristics in accordance with CECC 22000, Equivalent Test Conditions

**Temperature Rating** — -55 to +155°C  
**Vibration** — MIL-STD-202, Method 204, Condition B  
**Shock** — MIL-STD-202, Method 213, Condition A  
**Moisture Resistance** — MIL-STD-202, Method 106  
**Thermal Shock** — MIL-STD-202, Method 107, Condition B

**Note:** Performance specifications are typical, but may not apply to all connector types.

### Related Product Data

**Product Specification** — 108-2084  
**Sample Kit** — 1654779

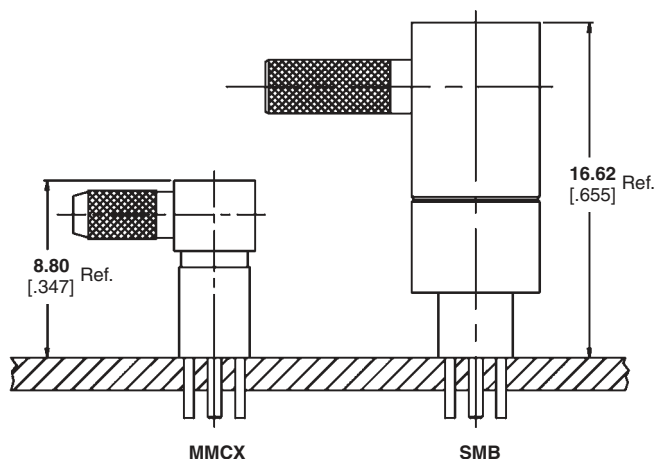

**MMCX Microminiature Snap-On Connector Series** (Continued)

**MMCX Interface Dimensions**

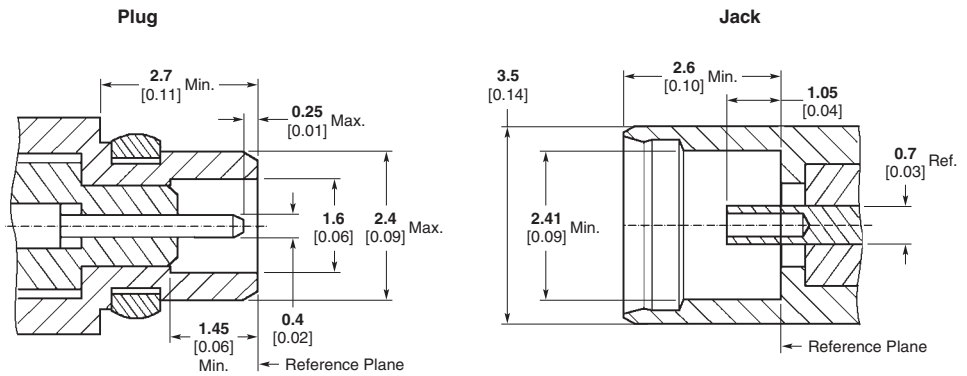

**Semi-Rigid Cable – Direct Solder Attachment**  
**Straight Cable Plug**

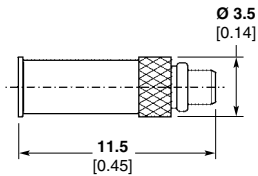

Cable	Part No.
RG 405	1408313-1

**Right-Angle Cable Plug**

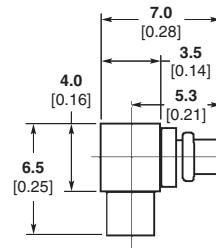

Cable	Part No.
RG 405	1408314-1

**Flexible Cable – Crimp Attachment**  
**Straight Cable Plugs**

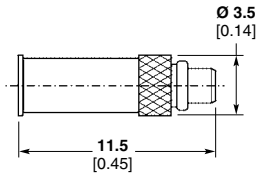

Cable	Part No.
RG 178, 196	1408148-1

Captured Center Contact

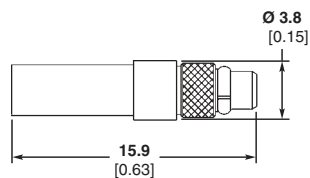

Cable	Part No.
RG 174, 188, 316	1408312-1
RD 316	1408312-2

Captured Center Contact

**Right-Angle Cable Plug**

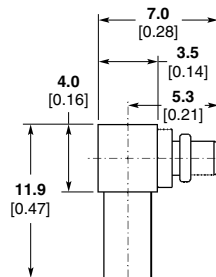

Cable	Part No.
RG 178, 196	1408149-1
RG 174, 188, 316	1408149-2
RD 316	1408149-3

Captured Center Contact

**Note:** Part Numbers are RoHS compliant except: ♦ Indicates non-RoHS compliant.

**MMCX Microminiature Snap-On Connector Series** (Continued)

**Printed Circuit Board  
Straight Jack Receptacle**

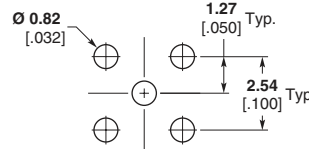
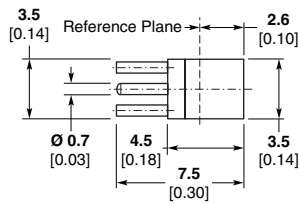

**Recommended Mounting Holes**

<b>Part No.</b>
<b>1408150-1</b>

**Right-Angle Jack Receptacle**

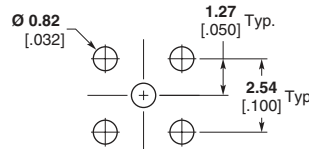
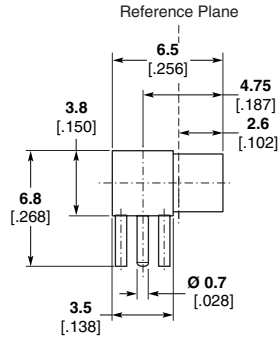

**Recommended Mounting Holes**

<b>Part No.</b>
<b>1408151-1</b>

**Straight Plug Receptacle**

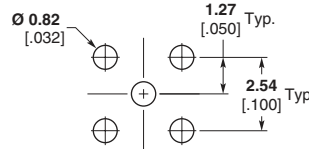
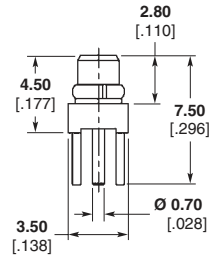

**Recommended Mounting Holes**

<b>Part No.</b>
<b>1408496-1</b>

**Surface Mount  
Straight Jack Receptacle**

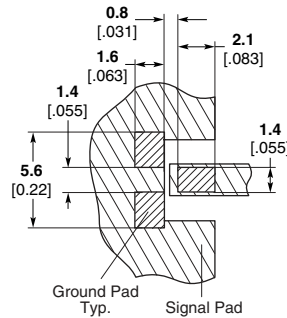
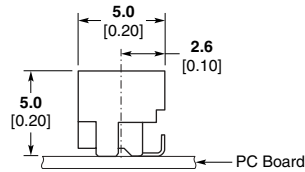

**Recommended Mounting Pattern**

<b>Part No.</b>
<b>1393757-6</b>

**Right-Angle Jack Receptacle**

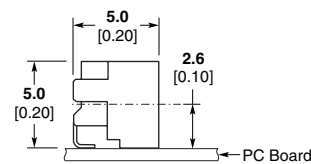

**Recommended Mounting Pattern**

<b>Part No.</b>
<b>1393757-7</b>

**Note:** Part Numbers are RoHS compliant except: ♦ Indicates non-RoHS compliant.

**MMCX Microminiature Snap-On Connector Series** (Continued)

**Edge Mount**  
**Straight Jack Receptacle**

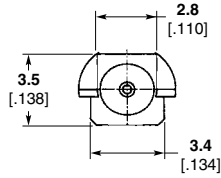

<b>Part No.</b>
<b>1408152-1</b>

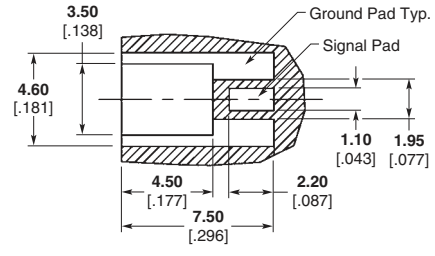
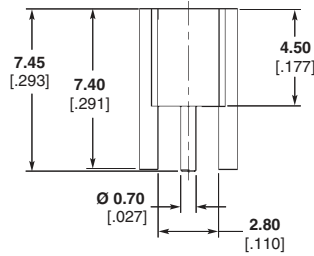

**Solder Pad Configuration Only**

**Straight Plug Receptacle**

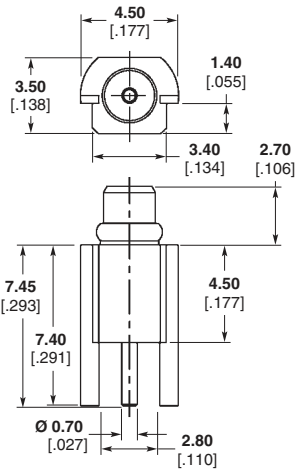

<b>Part No.</b>
<b>1408120-1</b>

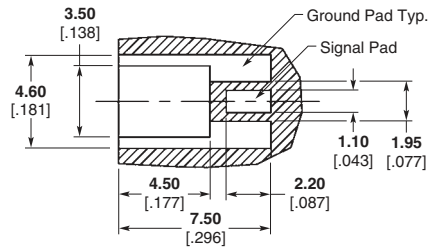

**Solder Pad Configuration Only**

**Note:** Part Numbers are RoHS compliant except: ♦ Indicates non-RoHS compliant.

## UMCC — Ultraminiature Coax Connector and Cable Assembly Series

### Product Facts

- Ultra low profile (2.0 mm or 2.5 mm maximum mated height)
- Easy snap on/off mating
- Small footprint on PCB (3 mm x 3 mm)
- Excellent performance to 6 GHz
- Surface mount and reflow solderable
- Available on 0.80 mm and 1.37 mm dia. single shield, and 1.32 mm dia. double shield cable
- Style A receptacles mate with HIROSE U.FL/U.FL(v) Series connectors
- Style B receptacles mate with MURATA GSC Series connectors

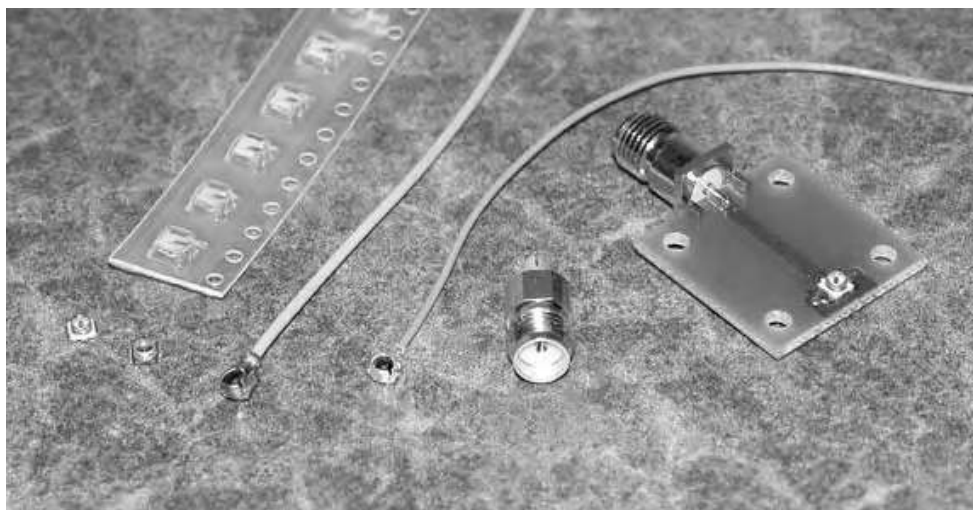

### Description

- Extremely low profile
- Surface mount technology
- 360° mated rotation
- Excellent price-to-performance ratio

### Applications

- Wireless LAN, Mini PCI
- Mobile Antenna/GPS/Radio Systems
- PDA/PCS/Cellular Handset applications
- Wireless Communications systems (LAN, GSM, PCS, WCDMA, UMTS)
- Remote measuring equipment

### Electrical Characteristics

- Characteristic Impedance** — 50 Ohms
- Frequency Range** — DC to 6 GHz
- VSWR (mated pair)** — 1.30 max. DC to 3 GHz  
1.40 max. 3 to 6 GHz (cable dependent)
- Insertion Loss (connectors only)** — 0.24 dB max. DC to 6 GHz
- Rated Voltage** — 60 VAC (rms) — standard receptacle (Styles A, B)
- Dielectric Withstanding Voltage** — 200 VAC, 50 Hz for 1 min. @ sea level
- Insulation Resistance** — 500 Megohms min.
- Contact Resistance (connectors only)** — 20 milliohms max. (Center)  
10 milliohms max. (Outer, Plug)  
10 milliohms max. (Outer, Receptacle)

### Mechanical and Environmental Characteristics

- Durability** — 30 cycles — standard receptacle (Styles A, B)
- Disengagement Force** — 2N min. perpendicular  
4N min. orthogonal
- Center Contact Retention Force** — 0.15N min.
- Tape/Reel Packaging (receptacle)** — 12 mm carrier per EIA-481
- Operating Temperature** — -40°C to +90°C

### Material and Finish

- Shell** — Phosphor bronze, plated gold or silver
- Male Center Contact** — Brass or phosphor bronze, plated gold
- Female Center Contact** — Brass or phosphor bronze, plated gold
- Insulator (Plug)** — PBT (15% G.F.), black, UL94V-0
- Insulator (Receptacle)** — LCP, beige or black, UL94V-0

### Related Product Data

- Product Specification** — 108-2231
- Sample Kit** — 1-1773441-6

HIROSE is a trademark of Hirose Electric.  
MURATA is a trademark of Murata Electronics, Inc.

**UMCC — Ultraminiature Coax Connector and Cable Assembly Series** (Continued)

**Cable Information**

**Material and Finish**

**Center Conductor** —  
0.8 mm Dia. — Silver plated copper  
1.32 mm Dia. — Silver plated copper  
1.37 mm Dia. — Silver plated copper

**Center Conductor Size** —  
0.8 mm Dia. — Stranded 7/0.05 mm  
1.32 mm Dia. — Stranded 7/0.08 mm  
1.37 mm Dia. — Stranded 7/0.10 mm

**Dielectric** —  
0.8 mm Dia. — FEP or PFA  
1.32 mm Dia. — FEP  
1.37 mm Dia. — FEP

**Dielectric Size** —  
0.8 mm Dia. — 0.4 mm OD  
1.32 mm Dia. — 0.66 mm OD  
1.37 mm Dia. — 0.83 mm OD

**Shield** —  
0.8 mm Dia. — Silver plated copper braid  
1.32 mm Dia. — Double SPL braid  
1.37 mm Dia. — Silver plated copper braid

**Shield Coverage** —  
0.8 mm Dia. — > 90%  
1.32 mm Dia. — > 90% (each braid layer)  
1.37 mm Dia. — > 90%

**Jacket** —  
0.8 mm Dia. — FEP or PFA  
1.32 mm Dia. — FEP  
1.37 mm Dia. — FEP

**Jacket Size** —  
0.8 mm Dia. — 0.80 mm OD  
1.32 mm Dia. — 1.32 mm OD  
1.37 mm Dia. — 1.37 mm OD

**Mechanical Characteristics**

**Minimum Bend Radius** —  
0.8 mm Dia. — 5 mm single bend, 30 mm continuous flexing  
1.32 mm Dia. — 5 mm single bend, 30 mm continuous flexing  
1.37 mm Dia. — 5 mm single bend, 30 mm continuous flexing

**Electrical Characteristics**

**Impedance (Ohms)** —  
0.8 mm Dia. —  $50 \pm 2$   
1.32 mm Dia. —  $50 \pm 2$   
1.37 mm Dia. —  $50 \pm 2$

**Velocity of Propagation** —  
0.8 mm Dia. — 70%  
1.32 mm Dia. — 70%  
1.37 mm Dia. — 70%

**CC Resistance (Ohms/KM)** —  
0.8 mm Dia. — 1450  
1.32 mm Dia. — 560  
1.37 mm Dia. — 354

**Voltage Rating** —  
0.8 mm Dia. — 60 VAC  
1.32 mm Dia. — 60 VAC  
1.37 mm Dia. — 60 VAC

**Attenuation** — See chart

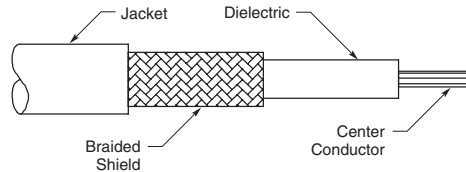

**UMCC Cable Attenuation**

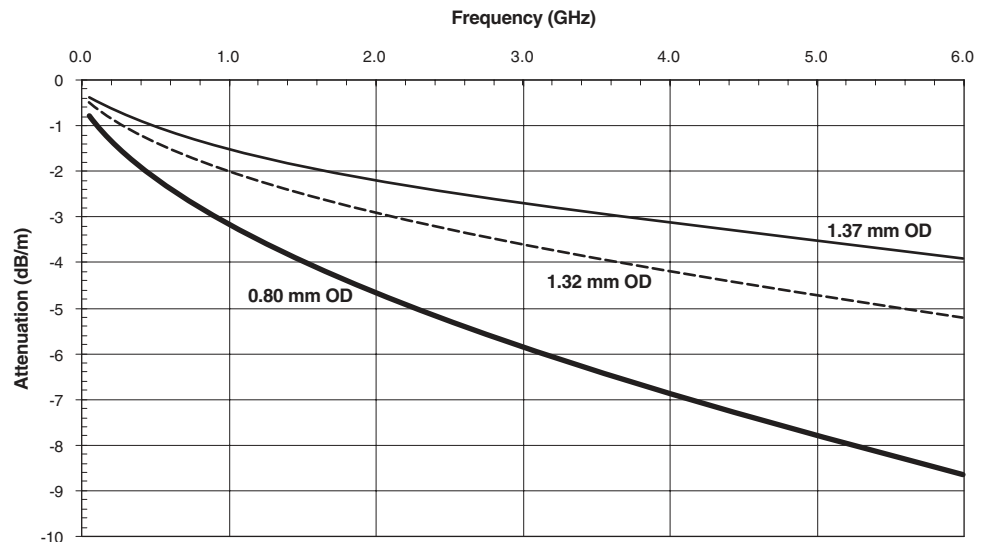

**UMCC — Ultraminiature Coax Connector and Cable Assembly Series** (Continued)

**PCB Receptacles —  
Style A**

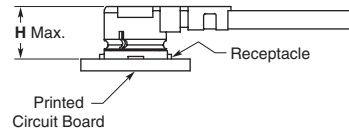

Style	Mates with UMCC Connector Type	Mated Height (H)	Description	Part Number
A	II / III	2.00–2.50 .079–.098	UMCC PCB Receptacle, 2500 Pc Reel	1566230-1
A	II / III	2.00–2.50 .079–.098	UMCC PCB Receptacle, 500 Pc Bag	1566230-2

**UMCC PCB Receptacle**

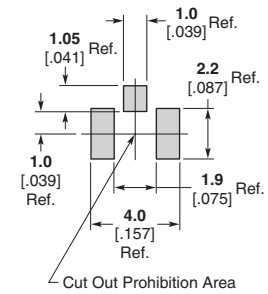
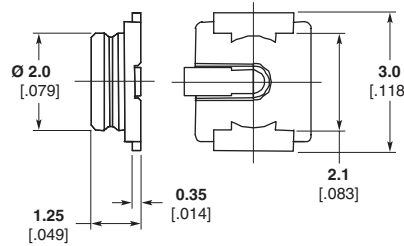
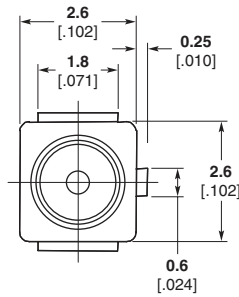

**Recommended PC Board Layout**

**PCB Receptacles —  
Style B**

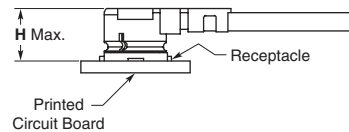

Style	Mates with UMCC Connector Type	Mated Height (H)	Description	Part Number
B	I	2.00 .079	UMCC PCB Receptacle, 2500 Pc Reel	1775146-1
B	I	2.00 .079	UMCC PCB Receptacle, 500 Pc Bag	1775146-2

**UMCC PCB Receptacle**

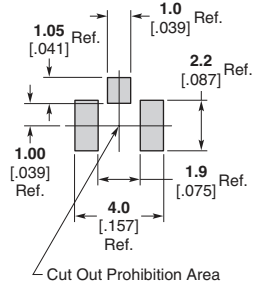
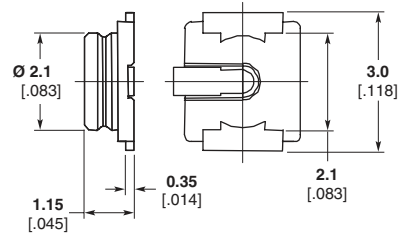
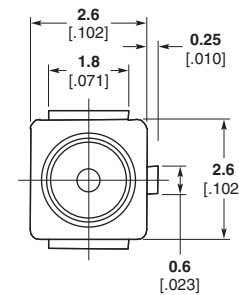

**Recommended PC Board Layout**

**Note:** Part Numbers are RoHS compliant except: ♦ Indicates non-RoHS compliant.



**UMCC — Ultraminiature Coax Connector and Cable Assembly Series** (Continued)

**Standard Double Ended  
Cable Assemblies**

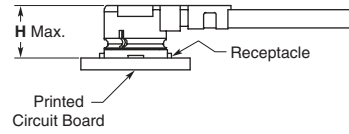

UMCC Connector Type	Mated Height (H)	Cable Dia.	Length L	Mates with PCB Rcpt.	Part Number
I	2.00 .079	0.80 .031	100.00 3.937	Style B	1750109-1
	2.00 .079	0.80 .031	200.00 7.874	Style B	1750109-2
II	2.00 .079	0.80 .031	100.00 3.937	Style A	1750108-1
	2.00 .079	0.80 .031	200.00 7.874	Style A	1750108-2
III	2.50 .098	0.80 .031	100.00 3.937	Style A	1750107-1
	2.50 .098	0.80 .031	200.00 7.874	Style A	1750107-2
	2.50 .098	1.32 .052	100.00 3.937	Style A	1750107-3
	2.50 .098	1.32 .052	200.00 7.874	Style A	1750107-4
III	2.50 .098	1.37 .054	100.00 3.937	Style A	1750107-5
	2.50 .098	1.37 .054	200.00 7.874	Style A	1750107-6

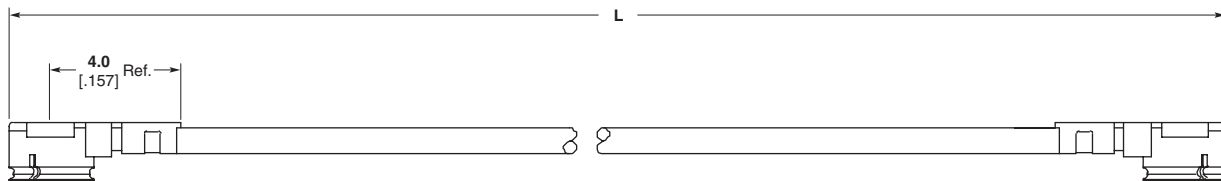

**Note:** Part Numbers are RoHS compliant except: ♦ Indicates non-RoHS compliant.



**UMCC — Ultraminiature Coax Connector and Cable Assembly Series** (Continued)

**Interseries Cable Assemblies**



UMCC Connector Type	Mated Height (H)	Cable Dia.	Length	Description	Part Number
III	2.50 .098	1.37 .054	200.00 7.874	UMCC Plug to FME Plug	1750110-2
	2.50 .098	1.37 .054	200.00 7.874	UMCC Plug to SMA Plug	1750110-4
	2.50 .098	1.37 .054	200.00 7.874	UMCC Plug to SMA Bulkhead Jack	1750110-6
	2.50 .098	1.37 .054	200.00 7.874	UMCC Plug to MCX Right-Angle Plug	1750110-8
	2.50 .098	1.37 .054	200.00 7.874	UMCC Plug to MMCX Right-Angle Plug	1-1750110-0
II	2.00 .079	0.80 .031	200.00 7.874	UMCC Plug to MCX Right-Angle Plug	1750110-7
	2.00 .079	0.80 .031	200.00 7.874	UMCC Plug to MMCX Right-Angle Plug	1750110-9

**UMCC to FME Plug**

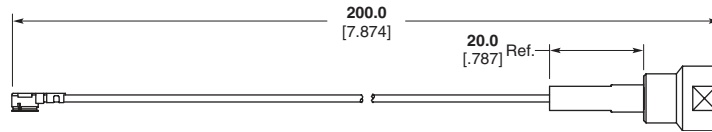

**UMCC to SMA Plug**

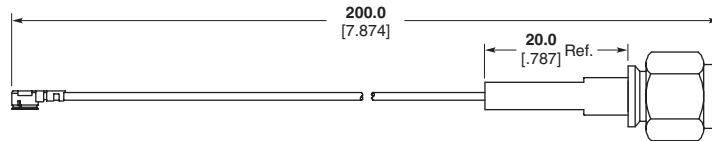

**UMCC to SMA Bulkhead Jack**

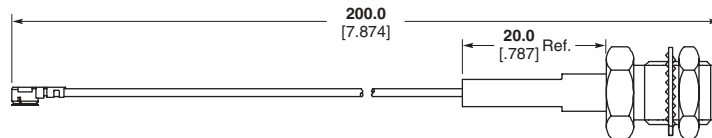

**UMCC to MCX Right-Angle Plug**

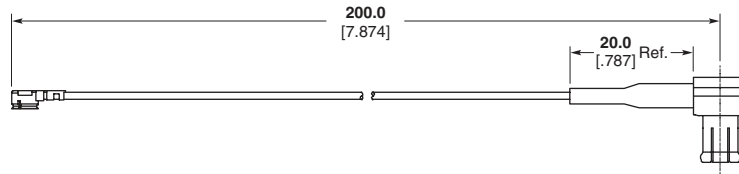

**UMCC to MMCX Right-Angle Plug**

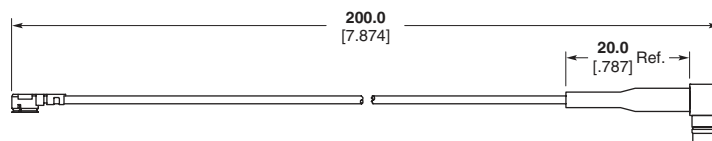

**Note:** Part Numbers are RoHS compliant except: ♦ Indicates non-RoHS compliant.

**UMCC — Ultraminiature Coax Connector and Cable Assembly Series** (Continued)

**Adapters**



UMCC Connector Type	Description	Part Number
I	UMCC Jack Receptacle to SMA Plug	1775228-1
	UMCC Plug to SMA Jack	1775229-1
II / III	UMCC Jack Receptacle to SMA Plug	1775227-1
	UMCC Plug to SMA Jack	1775230-1

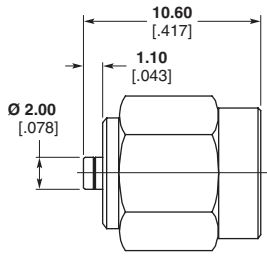

Part Number 1775228-1

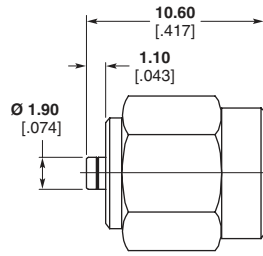
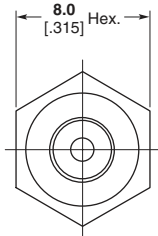

Part Number 1775227-1

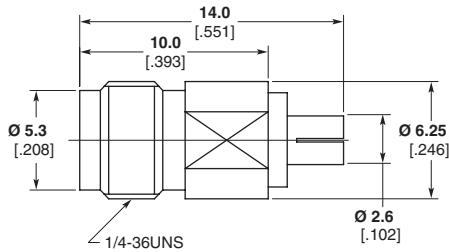
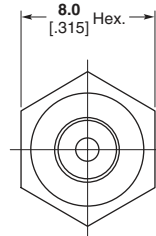

Part Number 1775229-1

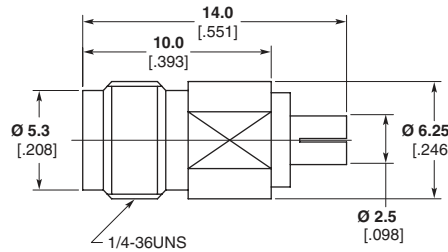
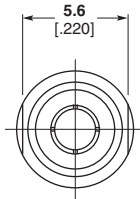

Part Number 1775230-1

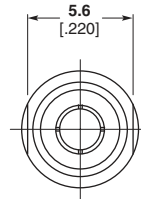

**Extraction Tool**  
**Part Number 1775231-1**

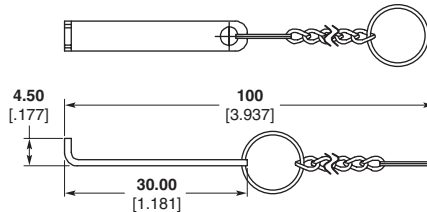

**Note:** Part Numbers are RoHS compliant except: ♦ Indicates non-RoHS compliant.

**UMCC — Ultraminiature Coax Connector and Cable Assembly Series (Continued)**

**Application Notes**  
**Mating/Unmating — Cable Plugs**

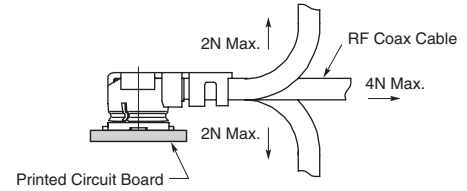
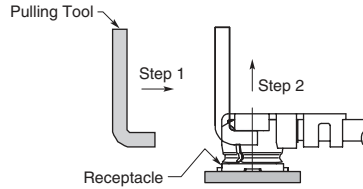

**Mating/Unmating**

1. To mate the connectors, insert the cable plug into the SMT receptacle, making sure the cable plug is as vertical as possible and the mating axis of both connectors are aligned. Do not insert on an extreme angle.
2. To unmate the connectors, insert the end portion of the extraction tool under the SMT receptacle connector flanges and pull off vertically in the direction of the mating axis.

**Permissible Load**

Do not apply excessive load to the cable after the connectors are mated. Please refer to the permissible loads indicated in the figure to the right.

**Tape and Reel Packaging Specifications**

**Standard Receptacles**

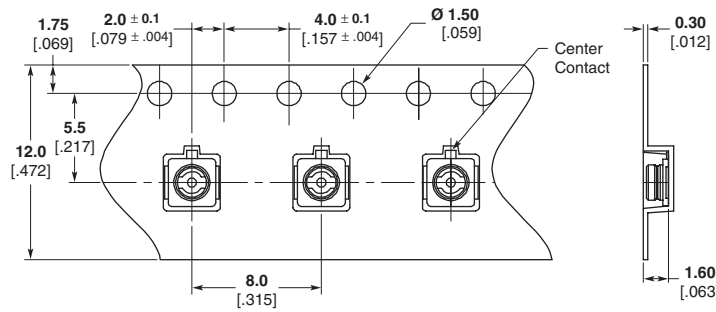

Dimensions of Taping

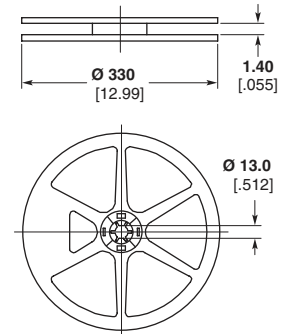

Dimensions Reel (2500 Pieces/Reel)

**Soldering Profile — SMT Receptacle**

**Recommended Temperature Profile (Reference)**

1. The preferred technique for mounting the SMT Receptacle package is to reflow solder the device onto a PCB (Printed Circuit Board).
2. The maximum temperature for the lead of PCB surface does not exceed 240°C.
3. The right reflow soldering profile is for reference and will modify under individual different conditions.

**Hand Soldering (Reference only)**

1. Soldering iron: The maximum temperature is 240°C.
2. Soldering period: within 5 seconds.

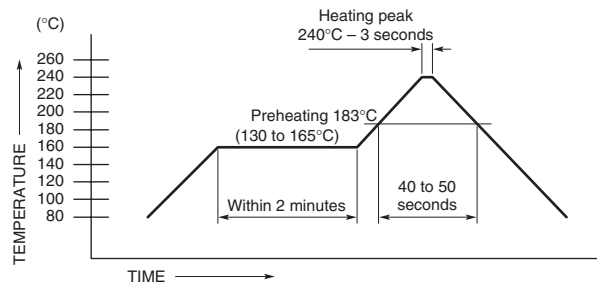

**COAXICON Series Mobile Phone Switching Coax Connectors**

**Product Facts**

- Able to switch RF signal from internal to external antenna
- SMD component for standard pick & place
- Up to 2.4 GHz
- Up to 30,000 life cycles
- High radial and axial tolerance capture
- Low insertion loss
- Right-angle cable plug with floating for alignment tolerance capture
- Application in handsets



**Product Specification**

108-71000

**Technical Features**

- Impedance** — 50 Ohms
  - Operating Temperature** — -40°C to +85°C
  - Radial Tolerance Capture** — ±1.0 [.039] (except for 3.5 [.138] height)
  - Axial Tolerance Capture** — 0.6 [.024]
  - Plating** — Outer shell and center contact are gold plated
  - Short Stamped Contact** — Selective gold plating
  - Long Stamp Contact (switch)** — Full gold plating with ink barrier
  - Insertion Loss** — 0.30 dB max. at 2 GHz
  - Isolation** — 26 dB min. at 2 GHz
  - VSWR** — 1.15:1 at 1 GHz, below 1.20:1 at 2 GHz
  - Mated Insertion Loss (after life cycle testing)** — Below 0.30 dB at 1 GHz, below 0.45 dB at 2 GHz
  - Unmated Insertion Loss (after life cycle testing)** — Below 0.20 dB at 1 GHz, below 0.35 dB at 2 GHz
- Packaging on reels for SMD.  
For more details, refer to the product specification.

The Tyco Electronics SMD mobile phone connector system offers a low-cost and effective solution to passive switching between an internal and external phone antenna. When implemented in a cradle kit, the connector helps to make possible hands-free operation of the mobile

phone within a vehicle, enhancing safety and permitting compliance with a growing body of legislation. Connection to the external antenna also enhances signal gain and clarity.

The connector design accommodates gross misalignment between the

phone and cradle, which is extremely important when blindmating is necessary. The Tyco Electronics switching coax connector system meets all performance objectives, including up to 30,000 connect/disconnect and switching cycles over the connector's life.

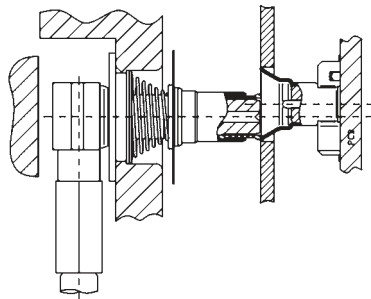

Figure 1 — System Configuration

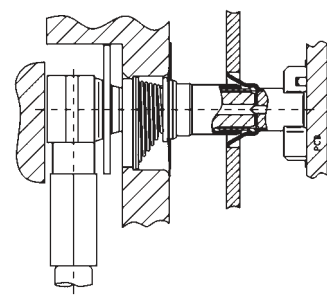
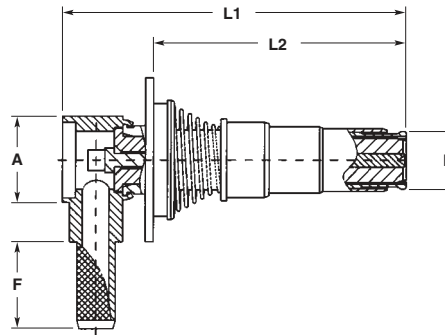

Figure 2 — System Configuration

**COAXICON Series Mobile Phone Switching Coax Connectors** (Continued)

**Right-Angle Cable Plugs**



Note: Hex Crimp Dim. 3.25 [.128]

RG/U Cable	Dimensions					Single Packed Part No.	Bulk Packed Part No.	
	A	D	F	L1	L2			
RG 174	5x5 Square	3.4 .134	6.9 .272	15.6 .614	10.9 .429	619028-2	5-619028-2	
	5x5 Square	3.4 .134	9.6 .378	15.6 .614	10.9 .429	619028-4	5-619028-4	
		6.0 .236	3.4 .134	6.9 .272	15.8 .622	10.9 .429	619041-2	5-619041-2
		6.0 .236	3.4 .134	9.6 .378	15.8 .622	10.9 .429	619041-4	5-619041-4
		6.0 .236	3.4 .134	6.9 .272	20.3 .799	11.0 .433	619078-1	5-619078-3
		6.0 .236	3.4 .134	9.6 .378	20.3 .799	11.0 .433	619078-2	5-619078-4

**SMD Switching Jacks**

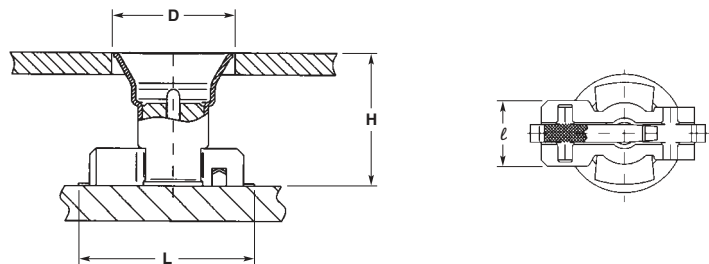

H	Dimensions			Diameter D	Part No.
	L	l			
6.0 .236	8.0 .315	3.2 .126		5.4 .213	619061-1
4.5 .177	8.0 .315	3.2 .126		5.4 .213	619062-1
3.5 .137	8.0 .315	3.2 .126		5.4 .213	619072-1

Other models upon request.  
For all dimensions, stencil and PCB recommended layout, see customer drawing.  
\*Dim.  $l$  is the width of the connector on the PCB.

Note: Part Numbers are RoHS compliant except: ♦ Indicates non-RoHS compliant.

**COAXICON Series Mobile Phone Switching Coax Connectors (Continued)**

**Switching SMD Jack  
Low Profile**

**Part Number 619061-1,  
Part Number 619062-1, and  
Part Number 619072-1**

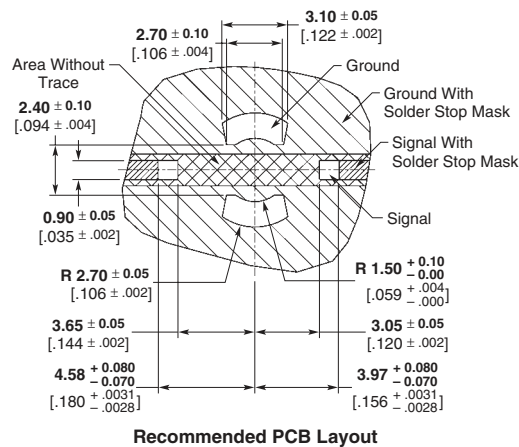
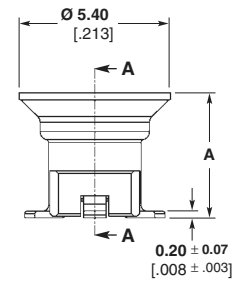
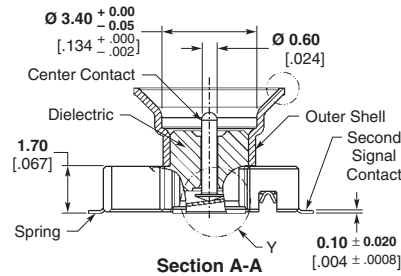
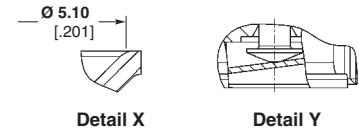
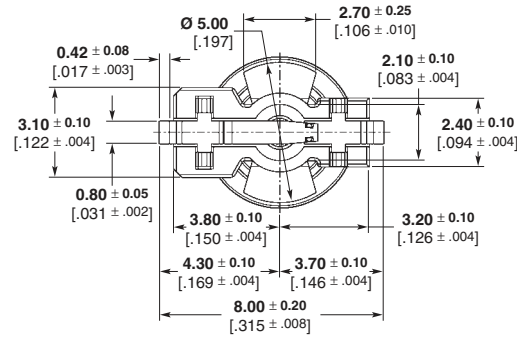

Plating	Dim. A	Part No.
Gold	6.00 ± 0.10 .236 ± .004	619061-1
Gold	4.50 ± 0.10 .177 ± .004	619062-1
Gold	3.50 ± 0.10 .138 ± .004	619072-1

**Note:** Part Numbers are RoHS compliant except: ♦ Indicates non-RoHS compliant.

**COAXICON Series Mobile Phone Switching Coax Connectors (Continued)**

**Switching SMD Jack**  
**ESD Protected**  
**Part Number 619133-3**

Plating — Gold

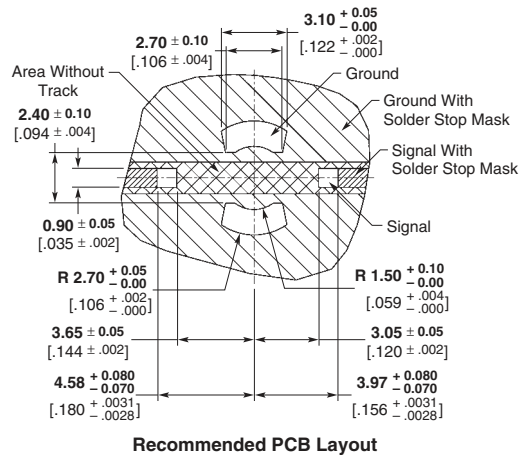
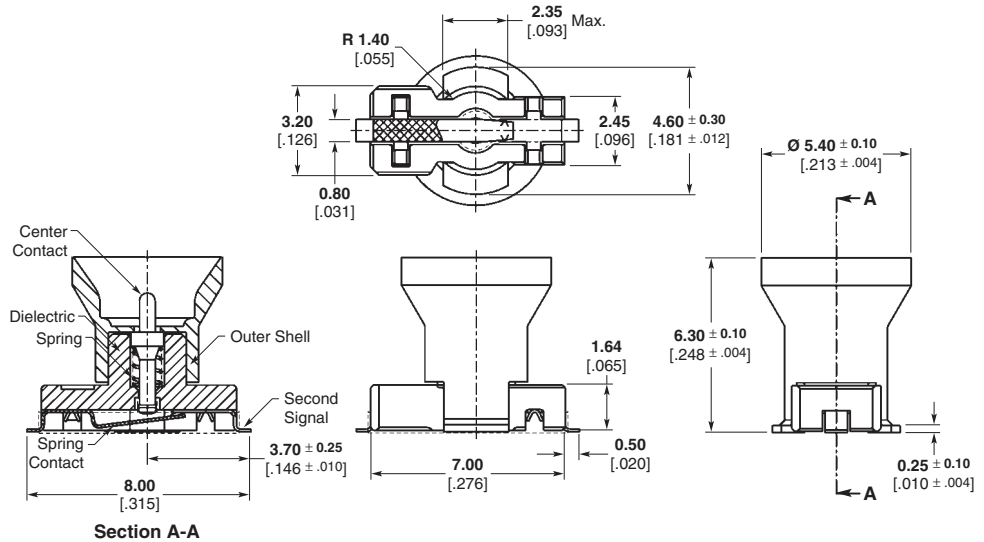

**Note:** Part Numbers are RoHS compliant except: ♦ Indicates non-RoHS compliant.

**COAXICON Series Mobile Phone Switching Coax Connectors (Continued)**

**Switching SMD Jack  
ESD Protected  
4.1mm Height  
Part Number 619201-1\***

Plating — Gold

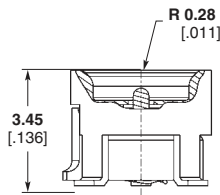

Mated Position

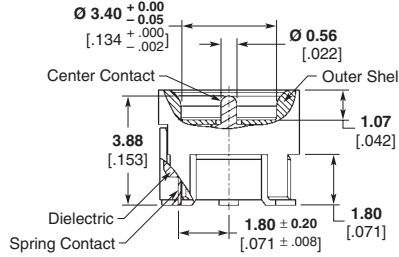
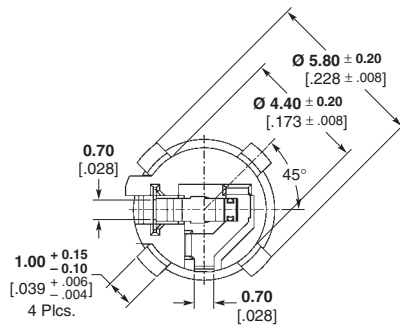

Unmated Position

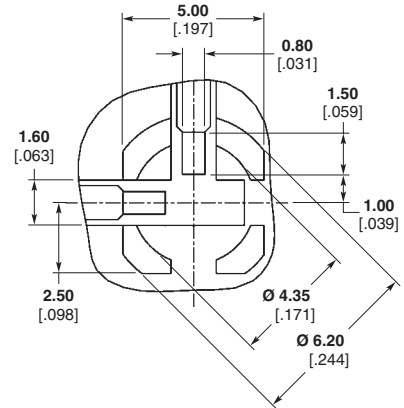

Recommended PCB Layout

\*Mirrored Version of Part Number 619201-1 Also Available Under Part Number 619231-1

**Switching SMD Jack Mid  
Part Number 619075-1**

Plating — Gold

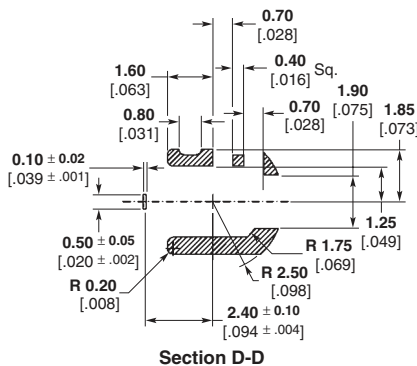

Section D-D

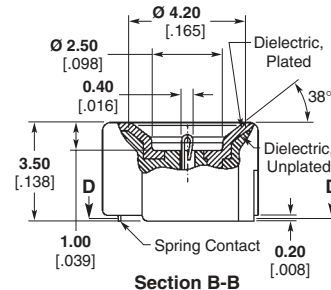
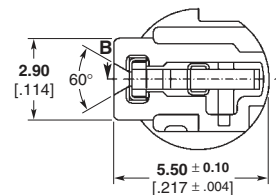
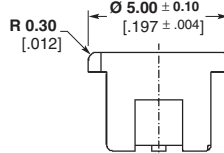

Section B-B

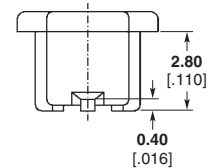

**Note:** Part Numbers are RoHS compliant except: ♦ Indicates non-RoHS compliant.



**COAXICON Series Mobile Phone Switching Coax Connectors (Continued)**

**Micro Switching Coax Connector**

Part Number 619196-1

Plating — Gold

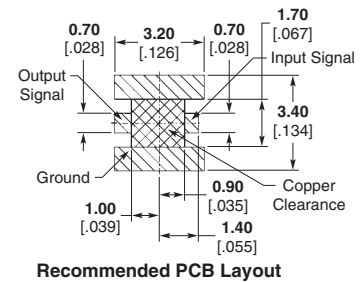
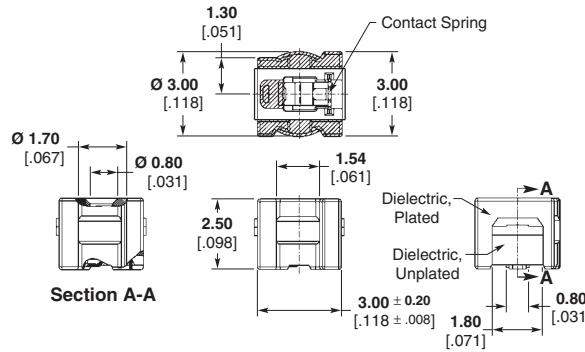

**Right-Angle Cable Plug For Micro Switching Coax Connector Cable RG 316/ RG 174**

Part Number 619211-2

Plating — Gold

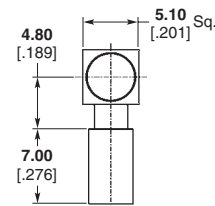
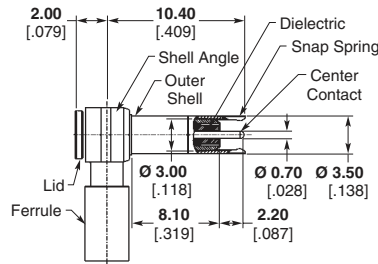

**Nano Switching Coax**

Part Number 619213-1

Plating — Gold

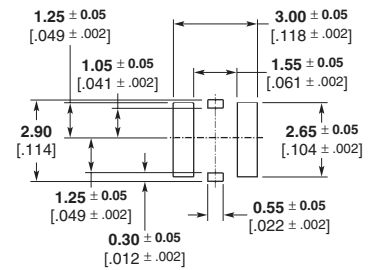
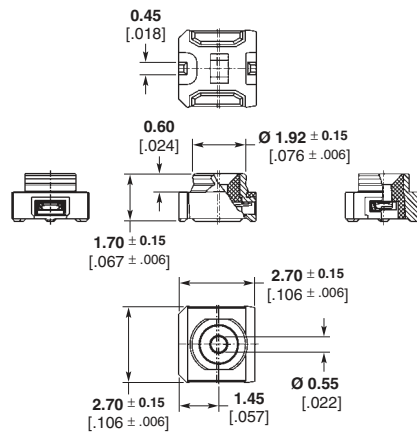
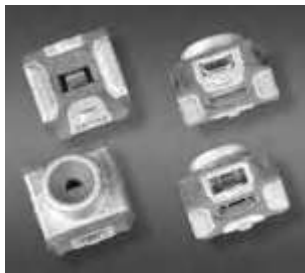

Recommended PCB Layout

Note: Part Numbers are RoHS compliant except: ♦ Indicates non-RoHS compliant.

**COAXICON Series Mobile Phone Switching Coax Connectors (Continued)**

**Protected Front Contact Cable Plug**

**Part Number 5-619028-1,  
Part Number 5-619078-1,  
and Part Number 5-619137-1**

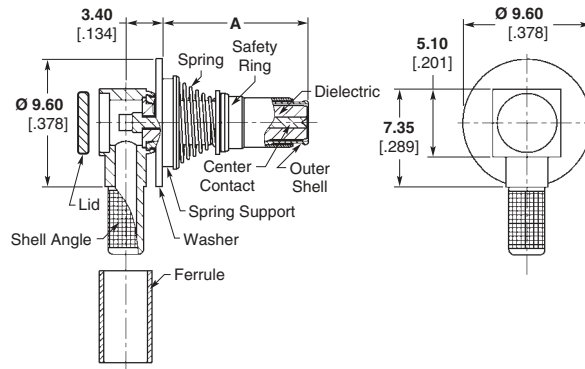

Plating	Dim. A	Part No.
Gold	10.92 .430	5-619028-1
Gold	14.90 .587	5-619078-1
Gold	10.92 .430	5-619137-1*

Bulk packaging.  
\*Outer conductor without slot.

**Protected Front Contact Cable Plug With Cylindrical Interface**

**Part Number 5-619076-2**

Plating — Gold  
Bulk packaging.

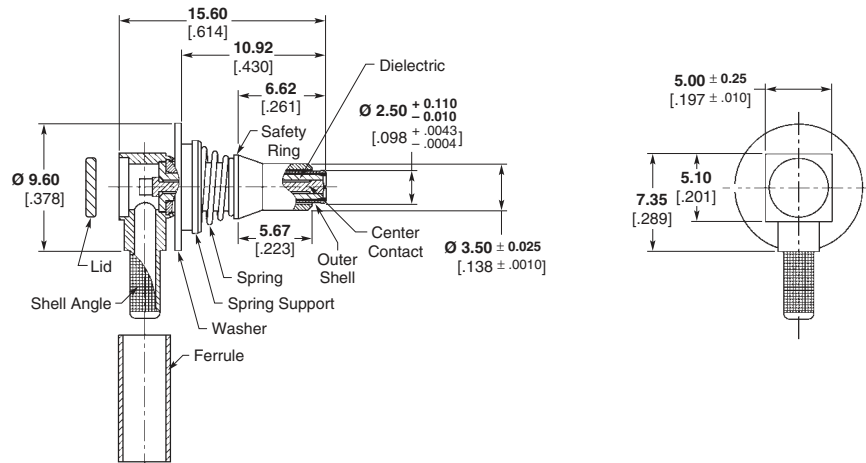

**Cable Plug/SMA Jack Adapter**

**Part Number 619052-1**

Plating — Gold

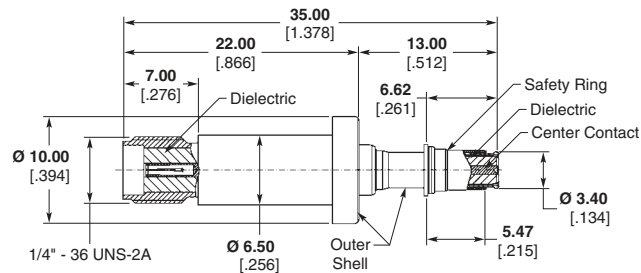

**Cable Plug/SMA Jack Adapter With Conical Flange**

**Part Number 619068-1**

Plating — Gold

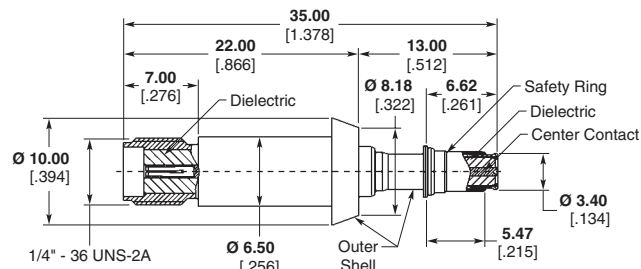

**Note:** Part Numbers are RoHS compliant except: ♦ Indicates non-RoHS compliant.

**COAXICON Series Mobile Phone Switching Coax Connectors (Continued)**

**Switching SMD Jack/  
SMA Jack Adapter  
Part Number 619053-1**

Plating — Gold

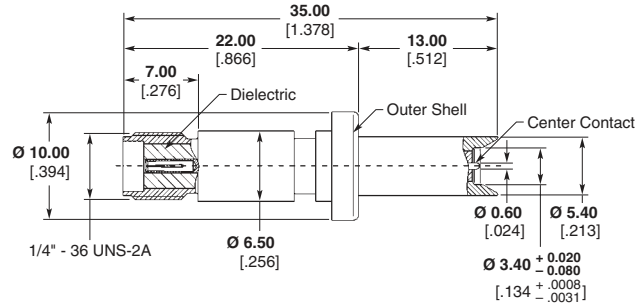

**Adapter SMA Jack —  
MSC Test Plug  
With Conical Flange  
Part Number 619210-1**

Plating — Gold

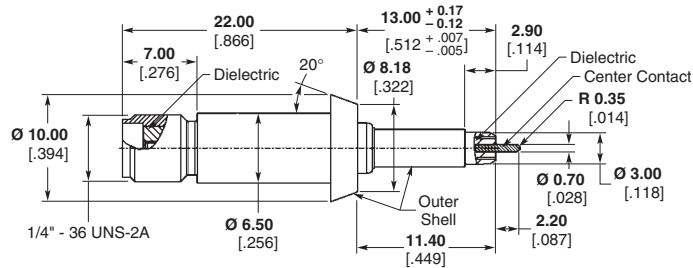

**Adapter SMA Jack —  
NSC Test Plug With  
Two-Hole Flange  
Part Number 619214-1**

Plating — Gold

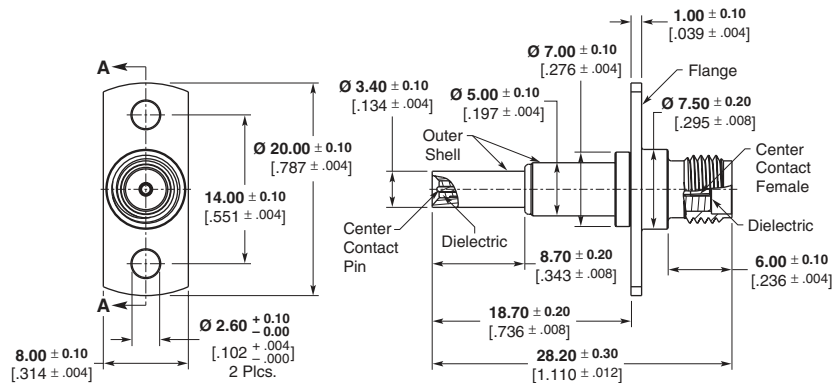

**Note:** Part Numbers are RoHS compliant except: ♦ Indicates non-RoHS compliant.

## Quick Snap Stripline (QSL) Coaxial Connector

### Coaxial Cable Displacement Interface

- Low profile
- Highly reliable ruggedized interface
- Surface mount technology
- Excellent price-to-performance ratio
- Platform expandable to include multi-port versions and other customization



### Product Facts

- Surface mount compatible
- RoHS compliant (lead-free SMT process [260° C] compatible)
- PCI / PCI Express compatible
- Designed for RG 174 & RG 316 Cable, and easily adaptable to other cable types
- Overall Height < 10 mm
- Can be packaged to meet IP67 Sealing
- 10mm x 10.6mm max. footprint (w/o panel extension)
- Cost effective solution to standard screw machine RF connectors

### Applications

- PCI, Mini PCI, PCI Express
- Mobile Antenna/GPS/Radio Systems/RFID
- PDA / PCS / Cellular Handset applications
- Wireless Communications systems
- Satellite Communications, Broadcast, Multimedia
- Automotive Telematics

### Related Product Data

Product Specification — 108-2224

### Specifications

**Characteristic Impedance** — 50 Ohms  
**Frequency Range** — Dc to 6 GHz  
**VSWR** — 1.3 Max to 3 GHz, 1.5 Max to 6 GHz  
**Rated Voltage** — 60 VAC rms  
**Dielectric Withstanding Voltage** — 800 VAC, 50 Hz (at sea level)  
**Insulation Resistance** — 100 Megohms min  
**Operating Temperature** — -40 to +125°C  
**Engagement Force** — < 30 N  
**Disengagement Force** — < 20 N  
**Cable Retention** — 110 N  
**Durability** — 250 cycles

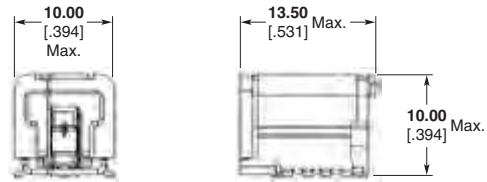

Surface Mount Jack Receptacle

Part Number
1274794-1

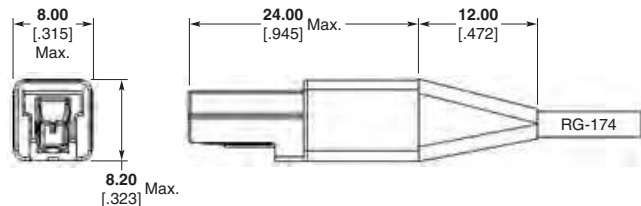

Cable Plug

Part Number
1274795-1

PCI, PCI EXPRESS are trademarks of PCI SIG.

**Note:** Part Numbers are RoHS compliant except: ♦ Indicates non-RoHS compliant.

## DIN Inserts

### Product Facts

- Meets requirements of DIN 41626 and CECC 22330
- Suitable for DIN 41612 Type M Connectors (Eurocard), Siedecon, and Z-PACK 2mm HM Connectors
- Meets DIN Performance Level II
- Crimp termination for inner and outer conductors (cable mount only) eliminates the need for solder
- Right-angle and vertical style board mount pin and socket contacts
- Board mount product available with both solder and compliant tails
- Straight cable mount pin and socket contacts for RG 316, and RG 179 cable
- Contact impedance of 50 and 75 ohms for cable mount and 50 ohms for board mount



*Coaxial inserts* according to CECC 22 330 and high-current inserts (CECC specification under preparation) can be used in conjunction with a DIN 41612 style M contact base (CECC 75 101-801), SIEDECON, and Z-PACK 2mm HM connectors.

*Coaxial inserts* have a contact system based on the pin-socket principle with the same dimensions as the Series 1.0/2.3 coaxial connectors and are plug-compatible. The product family is represented by various 50Ω and 75Ω styles that can be used far into the GHz range. The high mounting

density (pitch between adjacent contacts starting at 7.5 mm) and installation into the contact base, by means of a “snap-in” lock, make the inserts particularly well suited for applications.

- Due to the centering,
- coaxial plugs are installed in contact bases with audio-frequency (AF) female contacts
  - coaxial jacks are installed in contact bases with AF male contacts.

The high-quality materials used with coaxial inserts ensure a high grade of service even in an industrial atmosphere.

### Technical Data

**Electrical and mechanical characteristics of coaxial inserts in accordance with DIN 41626 Part 2 and CECC 22 330**

**Characteristic Impedance** — 50/75 Ω

**Frequency Range** — up to 2 GHz

**Reflection Factor Up To 2 GHz** <sup>1</sup> — ≤ 0.10

**Insulation Resistance** —  
Initial value — ≥ 1 GΩ  
After stressing — ≥ 200 MΩ

**Screening Effectiveness** — ≥ 70 dB

**Inner Conductor Contact Resistance After Stressing** — ≤ 10 mΩ

**Outer Conductor Continuity After Stressing** — ≤ 7.5 mΩ

**Voltage Proof** <sup>2</sup> —

**Flexible Cables (RG 316)**

At sea level — 750 V, 50 Hz

At 20 km altitude — 150 V, 50 Hz

**Working Voltage** <sup>2</sup> —

**Flexible Cables (RG 316)**

At sea level — 350 V, 50 Hz

At 20 km altitude — 65 V, 50 Hz

**Service Life** — 500 cycles

**Climatic Category** — 55/125/56

### Notes

<sup>1</sup> Guideline dimensions, depending on cable type and connector style.

<sup>2</sup> Some cable types suitable for use with these connectors have lower characteristic values than specified here.

**DIN Inserts (Continued)**

**Coaxial Inserts,  
50 Ohm  
Z-PACK 2mm  
HM Connectors**

**Vertical PC Board Mount, Compliant**

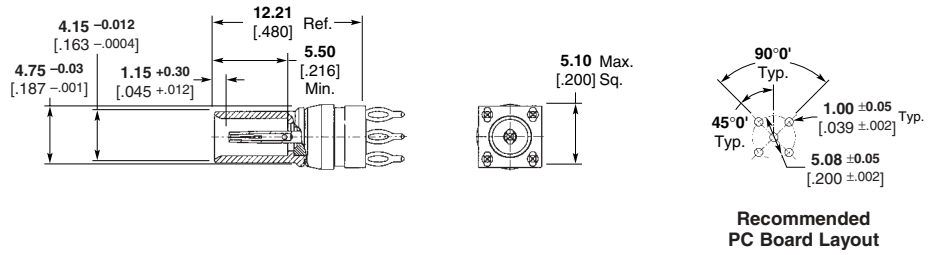

**Right-Angle PC Board Mount, Compliant**

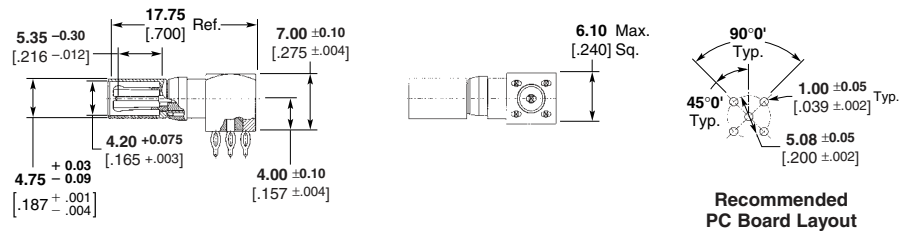

Type	Housing Type	Application Tooling	Part No.
Vertical PCB Socket, Compliant	Z-PACK 2mm HM Male	904800-1	5148385-1
Rt. Angle PCB Pin, Compliant	Z-PACK 2mm HM Female	904805-1 904804-1 Support Anvil	5148386-1

**Coaxial Inserts to SMA Adapters**

**Coaxial Insert Plug to SMA Jack**

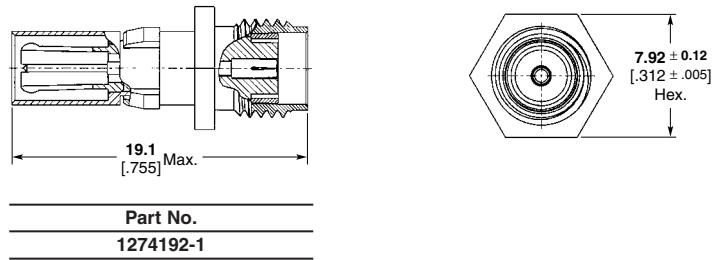

**Coaxial Insert Socket to SMA Jack**

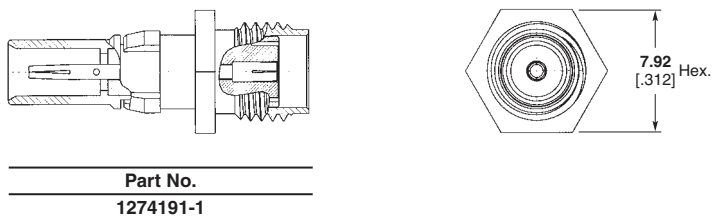

**Note:** Part Numbers are RoHS compliant except: ♦ Indicates non-RoHS compliant.

**DIN Inserts** (Continued)

**Coaxial Inserts (50 Ω/75 Ω)**

**Bulkhead Cable Jack for male connectors**

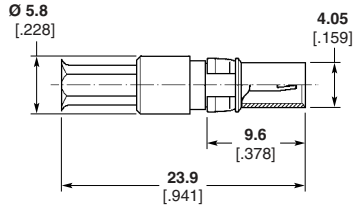

Ø Max.	Cable Type	Width Across Flats of Hex Profile	Part No.
2.6 .102	RG 316 (50 Ω)	3.2 .126	1392020-1
2.67 .105	RG 179 (75 Ω)	3.2 .126	3-1393668-4

**Bulkhead Cable Jack for female connectors**

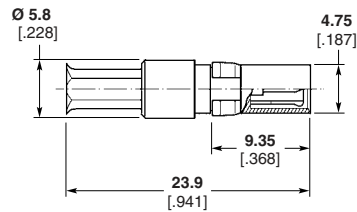

Ø Max.	Cable Type	Width Across Flats of Hex Profile	Part No.
2.6 .102	RG 316 (50 Ω)	3.2 .126	1392019-1
2.67 .105	RG 179 (75 Ω)	3.2 .126	3-1393668-0

**Right-Angle Bulkhead Jack for male connectors**

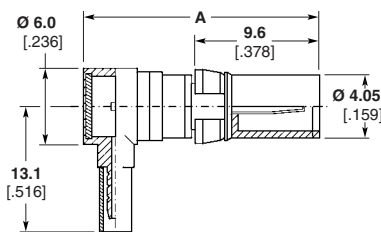

Dim A	Ø Max.	Cable Type	Width Across Flats of Hex Profile	Part No.
19 .748	2.6 .102	RG 316 (50 Ω)	3.2 .126	1-1393668-2
	2.67 .105	RG 179 (75 Ω)		
22.4 .882	2.67 .105	RG 179 (75 Ω)	3.2 .126	2-1393668-8
	2.67 .105	RG 179 (75 Ω)		
24.0 .945	2.67 .105	RG 179 (75 Ω)	3.2 .126	3-1393668-6

**Right-Angle Bulkhead Plug for female connectors**

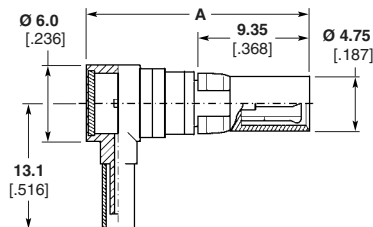

Dim A	Ø Max.	Cable Type	Width Across Flats of Hex Profile	Part No.
18.7 .736	2.6 .102	RG 316 (50 Ω)	3.2 .126	1393668-4
	2.6 .102	RG 316 (50 Ω)		
18.7 .736	3.0 .118	RD 316 (50 Ω)	3.6 .142	1393668-7
	2.67 .105	RG 179 (75 Ω)		
18.7 .736	2.67 .105	RG 179 (75 Ω)	3.2 .126	2-1393668-4

**Note:** Part Numbers are RoHS compliant except: ♦ Indicates non-RoHS compliant.



**DIN Inserts** (Continued)

**Coaxial Inserts (50 Ω/75 Ω)** (Continued)

**Bulkhead Plug, PC Board connection for DIN 41612 M female connectors**

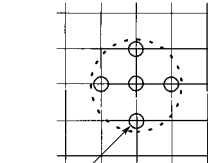
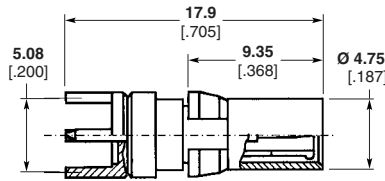

Ø 1.0  
[.039]  
**Recommended Mounting Hole**

Pitch 2.54  
[0.10]

Part No.  
1-1393662-0

**Right-Angle Bulkhead Jack, PC Board for DIN 41612 M male connectors**

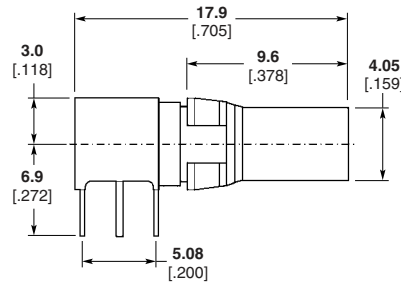

Part No.  
1-1393662-4

**Right-Angle Bulkhead Plug, PC Board for SIEDECON female connectors**

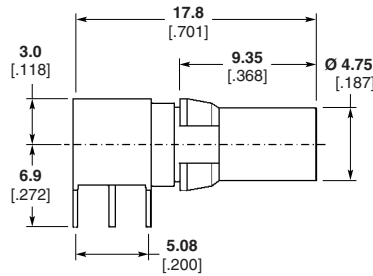

Part No.  
1-1393662-2

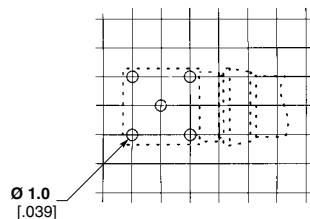

Pitch 2.54  
[0.10]

**Recommended Mounting holes for Part No. 1-1393662-2 and 1-1393662-4**

**Note:** Part Numbers are RoHS compliant except: ♦ Indicates non-RoHS compliant.



## Size 8 Contacts

### Performance Characteristics

**Frequency Range** — 0 to 500 MHz

**Operating Voltage, Max.** —  
275 vac rms @ sea level

**Termination Resistance, Max.** —  
Center Contact — 6.0 milliohms  
Outer Contact — 3.0 milliohms

**Insulation Resistance, Min.** —  
5,000 megohms @ 500 vdc

**Dielectric Withstanding Voltage** —  
Sea Level — 800 Volts rms  
30,000 ft [9,144 m] — 525 volts rms  
70,000 ft [21,336m] — 275 volts rms

**VSWR to 500MHz, Max.**

Pin/Socket	VSWR
Straight/Straight	1.30
Right-Angle/Straight	1.35
Right-Angle/Right-Angle	1.40

**RF Crosstalk** — 90dB @ 5-500 MHz

**Mating Force, Max.** — 4.0 lb  
[17.8 N]

**Unmating Force, Min.** — 2.0 oz  
[0.556 N]

**Contact Retention** — 20 lb [89 N]

**Contact Durability** — 500 cycles

Cable RG/U	Force	
	lb	[N]
316, 188, 174, 179, 179A, 179B	20	89
188-type Double-Braid	35	155.8
142, 142A, 142B	50	222.5

**Operating Temperature** —  
55°C to +125°C

**Thermal Shock** — 55°C to +125°C per  
MIL-STD-1344, Method 1003, Cond. A

**Physical Shock** — 50 G's per MIL-  
STD-1344, Method 2004, Cond. A

**Vibration** — MIL-STD-1344, Method  
2005, Cond. II

**Moisture Resistance** — 240 hours  
per MIL-STD-1344, Method 1002,  
Cond. II

**Salt Fog** — 48 hours per MIL-STD-  
1344, Method 1001, Cond. B

### Extraction Tool Numbers

**Subminiature D Housings** —  
58095-1 (AMPLIMITE)

**AMP-HDI Housings** — 58095-2

### Material

**Brass** — per QQ-B-626 and MIL-C-50

**Phosphor Bronze** — per QQ-B-750

**Beryllium Copper** — per QQ-C-530

**PTFE** — per MIL-P-19468

**Nylon** — per MIL-M-20693

### Finish

**Bright Tin Plating** — per ASTM-B-571

**Copper Plating** — per MIL-C-14550

**Gold Plating** — per MIL-G-45204

**Nickel Plating** — per QQ-N-290

## Straight Contacts

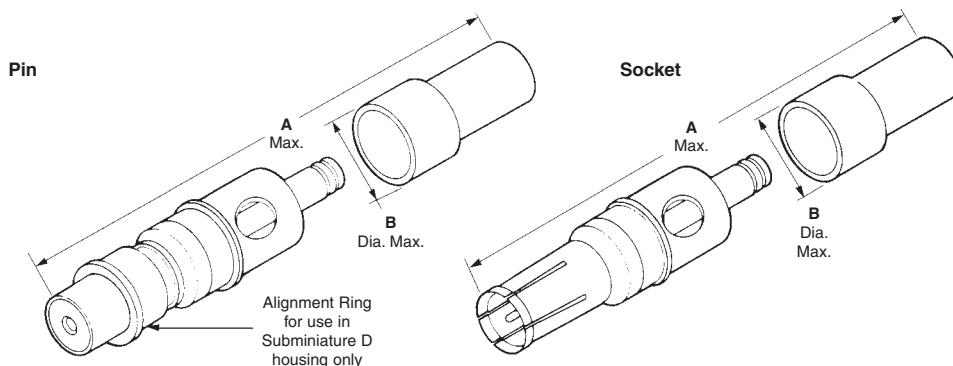

RG/Cable	Shell Type	Dimensions		Die Insert*	50 Ohm		Non-Impedance Matched	
		A	B		Pin	Socket	Pin	Socket
178, 178A 178B, 196, 196A	Brass	24.13 .950	5.94 .234	59993-1	—	—	5228618-5	5228596-5
174, 316, 188, 188A	Brass	24.28 .956	5.94 .234	59993-1	5221980-1	—	5228618-1	5228596-1
179, 179A, 179B, 187, 187A, 161, BELDEN 9221	Brass	24.28 .956	5.94 .234	59993-1	—	—	5228618-2	5228596-2
174, 316, 188, Double Braid	Brass	24.28 .956	5.94 .234	59993-1	—	—	5228618-3	5228596-3
142, 142A, 142B, 400, BELDEN 9246	Brass	27.43 1.08	6.48 .255	58212-1	—	5221981-2	5228618-4	5228596-4

\*For hand tool 69710-1 or pneumatic tool 69365-8.

**Note:** Non-Impedance Matched and 50 Ohm are not intermateable.

BELDEN is a trademark of Belden Wire  
and Cable Company.

**Note:** Part Numbers are RoHS compliant except: ♦ Indicates non-RoHS compliant.

**Size 8 Contacts** (Continued)

**PC Board Mount Contacts**

**Right-Angle Socket Contact**

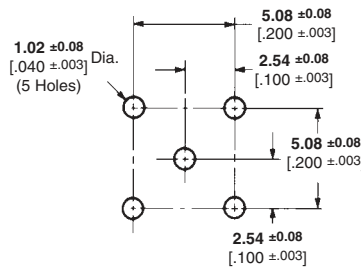
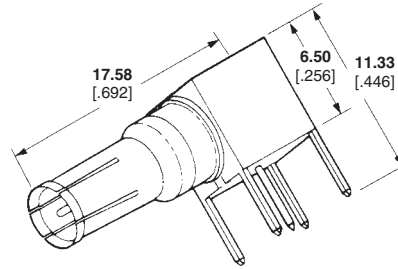

**Recommended PC Board Layout**

Type	Contact Part No. Non-Impedance Matched
Right-Angle Socket Contact	5221162-1

**Note:** Part Numbers are RoHS compliant except: ♦ Indicates non-RoHS compliant.

## COAXICON Contacts

### Product Facts

- Tyco Electronics provides a variety of contacts for coaxial connectors
- Contacts are available in a range of sizes that may be used with the various types of coaxial cable on the market
- COAXICON contacts are of the crimp, snap-in type and are available in the following designs: **Miniature Contacts, Subminiature Contacts and Size 8 Contacts**

**Miniature Contacts** are designed for high density multiple circuit connector applications. A wide range of cable sizes is accommodated by using three sizes of outer shell termination ends and three sizes of contacts.

**Subminiature Contacts** are used in high density applications and are ideal for mixing coaxial and other styles of pin and socket contacts in the same connector housing.

**Size 8 Contacts** are compatible with industry standard size 8 connectors such as Subminiature D and AMP-HDI connector housings. Straight and right-angle styles, as well as pc board versions for AMP-HDI connectors are available.



**Miniature Contacts**

**Performance Characteristics**

**Insulation Resistance** — 5000 megohms min

**Dielectric Withstanding Voltage** — 1,000 volts rms for 1 minute

**Contact Resistance** — 2.0 milliohms @ 1 ampere

**Low-Level Conductivity** — 10 milli-volts DC min.

**VSWR** — 1.3 to 1.0 @ 1,000 MHz max.

**Cable Retention** —

RG/U Cable	Retention lbs [N]
58C	50 [222]
188A	30 [133]
180B	28 [125]
195A	16 [71]

**Durability** — 500 cycles @ 10 cycles per minute max.

**Vibration** — 2 hrs. per MIL-STD-202, Method 201

**Shock** — 50 G's per MIL-Std-202, Method 213, Cond. G

**Temperature Cycling** — 5 cycles per MIL-STD-202, Method 102, Cond C.

**Temperature Range** — -55°C to +125°C

**Test Method for Electronic and Electrical Component Parts** — MIL-STD-202

**Material**

**Outer Shell** — Brass per MIL-C-50

**Center Conductor** — Brass per QQ-B-626, or Beryllium copper per QQ-C-533

**Note:**

A ferrule and retention spring (201142-2) are required for each pin and socket.  
Extraction Tool No. 305183-8

**Inner Dielectric** — Polypropylene, nylon, or polymethylpentene, general purpose

**Retention Spring** — Stainless steel per QQ-S-766

**Ferrule** — Copper per QQ-C-576

**Finish**

**Outer Shell, Center Conductor** — 0.00076 [.000030] gold over 0.00076 [.000030] nickel

**Retention Spring** — Nickel per QQ-N-290

**Ferrule** — Bright tin per MIL-T-10727

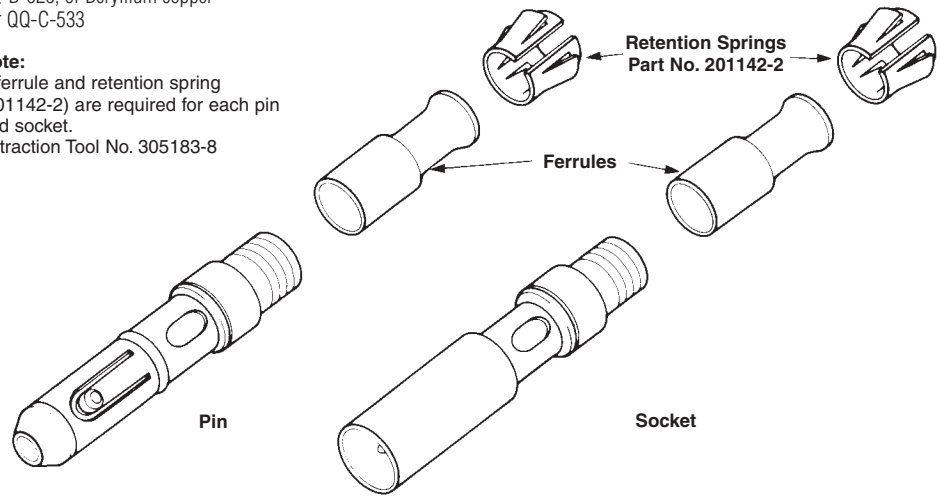

RG/U Cable	Ferrule No.	Integral Die Hand Tool	PRO-CRIMPER	Die Insert for Tools: Hand Tool 69710-1 Pneu. 69365-2, 69365-3 <sup>2</sup>	Part Numbers	
					Pin	Socket
316, 188, 188A 174	328666	—	—	69227-2	201143-5	201144-5
179, 179A, 179B 161, 187, 187A Belden 9221	328666	—	—	69227-2	201143-1	201144-1
188 Double Braid 316 Double Braid	221848-3	58290-1	—	69227-2	201143-5	201144-5
122	328664	45639-2	91912-3	69222-2	201145-1	—
180, 180A, 180B 195, 195A, 21-597	328664	45639-2	91912-3	69222-2	201145-2	201146-2
Belden 8218	328664	45639-2	91912-3	69222-2	201145-2	201146-2
58, 58A, 58B, 58C	328663	45740-2	—	69220-2	201145-4	201146-4
141 55, 55A, 55B, 223	330478	69248-4	—	69315-4	201145-4	201146-4
124, 140, 210 62, 62A, 62B 59, 59A, 59B	329006	—	—	69675-1	201097-1*	201098-1*
<b>Twisted Pair</b>						
24-22 AWG [0.2-0.4 mm <sup>2</sup> ] (Stranded) <sup>1</sup>	328666	91912-4	—	69672	201143-5	201144-5
Shielded Wire 22, NAS-702, Class B	328663	45740-2	—	69220-2	201145-4	201146-4
Brand Rex T5788A 26 AWG [0.12-0.155 mm <sup>2</sup> ] <sup>3</sup>	328664	45639-2	91912-3	69222-2	201145-2	201146-2

\*These contacts are for use in the 4-position G Series connector modules only.

<sup>1</sup>Maximum insulation diameter—2.92 [.115] (two wires combined).

<sup>2</sup>Includes bench mount and foot control; requires Manual Take-Up Attachment No. 69689.

<sup>3</sup>Dielectric O.D.—2.69 [.106] max.; Cable O.D.—4.06 [.160].

**Note:** Part Numbers are RoHS compliant except: ♦ Indicates non-RoHS compliant.

**Miniature PC Board Sockets**

**Material**

**Shell and Center Contact** — Brass per MIL-C-50 and QQ-B-626

**Dielectric** — Polypropylene, or Polymethylpentene, general purpose

**Finish**

**Center Contact** — 0.00076 [.000030] gold over copper

**Shell** — Gold plated per MIL-G-45204

**Performance Characteristics**

**Dielectric Withstanding Voltage** — 1,000 volts, rms

**Impedance** — Non-constant

**Operating Temperature Range** — -55°C to +85°C

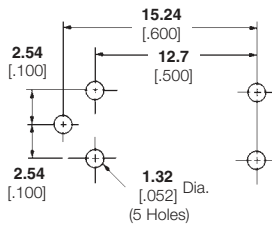
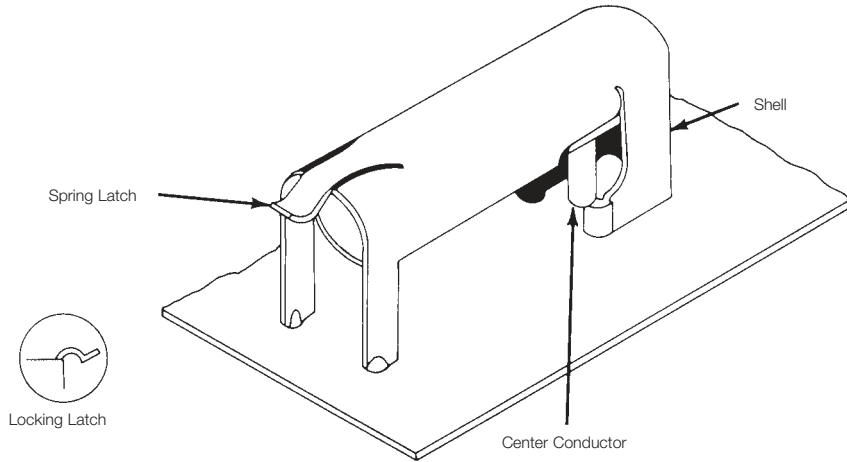

**Recommended Mounting Hole Layout**

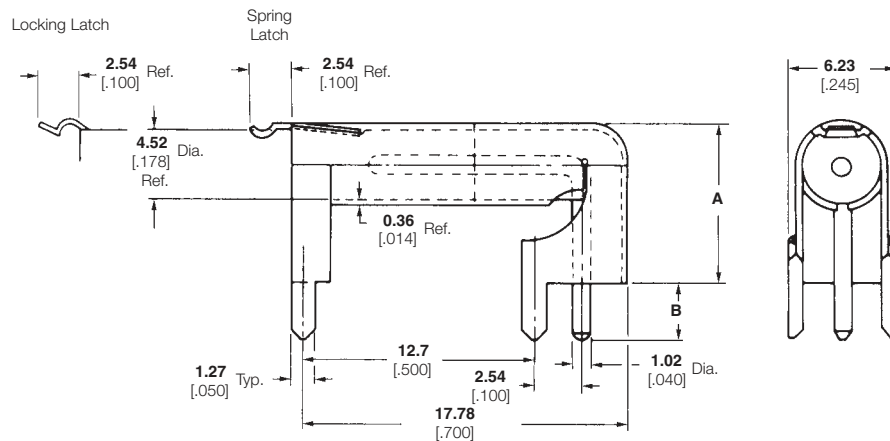

Type	PC Board Thickness	Retention		Dimensions		Part No.
		lb.	[N]	A	B	
Spring Latch	1.57 .062	1.25	5.56	9.07 .357	3.18 .125	50084-1
Spring Latch	3.18 .125	1.25	5.56	7.49 .295	4.75 .187	50095-1
Locking Latch	3.18 .125	7	31.1	7.49 .295	4.75 .187	50105-1
Locking Latch	1.57 .062	7	31.1	9.07 .357	3.18 .125	50107-1

**Note:** For mateable Miniature Contacts, see page 245.

**Note:** Part Numbers are RoHS compliant except: ♦ Indicates non-RoHS compliant.

## Subminiature PC Board Sockets

### Material

**Shell and Center Contact** — Brass per MIL-C-50 and QQ-B-626

**Dielectric** — Polypropylene, or polymethylpentene, general purpose

### Finish

**Center Contact** — 0.00076[.000030] gold per MIL-G-45204 over copper per MIL-C-14550

**Shell** — Gold

### Performance Characteristics

**Dielectric Withstanding Voltage** — 600 volts, rms

**Operating Temperature Range** — -55°C to +85°C

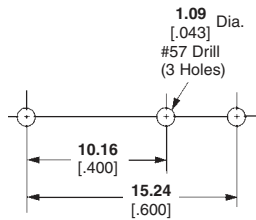
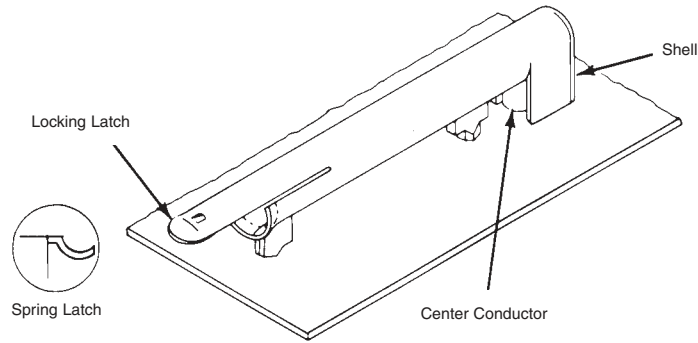

**Recommended  
Mounting Hole Layout**

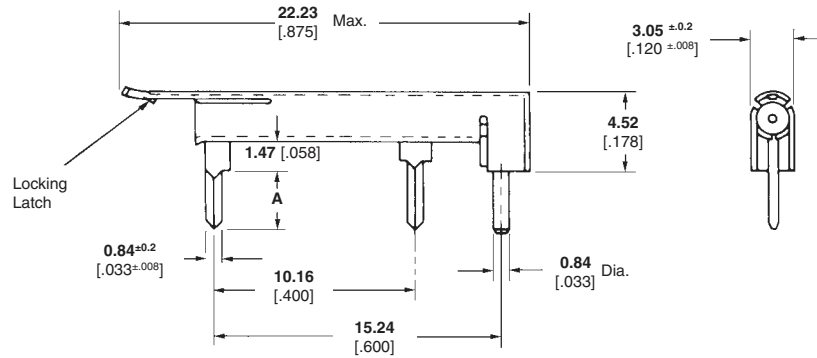

Type	PC Board Thickness	Dim. L	Part No.
Spring Latch	1.57 .062	2.54 .100	226023-1
Locking Latch	1.57 .062	2.54 .100	226060-1

### Mating Subminiature COAXICON Pins

These short Subminiature COAXICON Pins are recommended for use with any of the sockets listed above.

**Note:** Alignment springs are not required for this application and are not included with the pin assemblies.

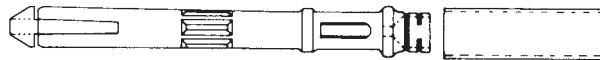

RG/U Cable	Ferrule No.	Integral Die Hand Tool	Die Insert for Tools: Hand Tool 69710-1 Pneu. 69365-2, 69365-3	Part No.
174 316, 188, 188A	1-332056-0	91911-3	69690	51563-8
179, 179A, 179B 187, 187A	1-332056-0	91911-4	69690-1	51563-8
161	1-332056-0	69656-5	—	51563-8

**Note:** Part Numbers are RoHS compliant except: ♦ Indicates non-RoHS compliant.

## Subminiature Contacts

### Material

**Outer Shell** — Brass per MIL-C-50

**Center Conductor** — Beryllium copper per QQ-C-533 (Pin); Brass per QQ-B-626 (Socket)

**Inner Dielectric** — Polypropylene, nylon, or polymethylpentene, general purpose

**Retention Spring** — Stainless steel per QQ-S-766

**Ferrule** — Copper per QQ-C-576

### Finish

**Outer Shell and Socket**

**Center Conductor** — 0.00076 [.000030] gold over 0.00127 [.000050] nickel

**Pin Center Conductor** — 0.00076

[.000030] gold over 0.00254 [.000100] copper

**Ferrule** — Bright tin per MIL-T-10727

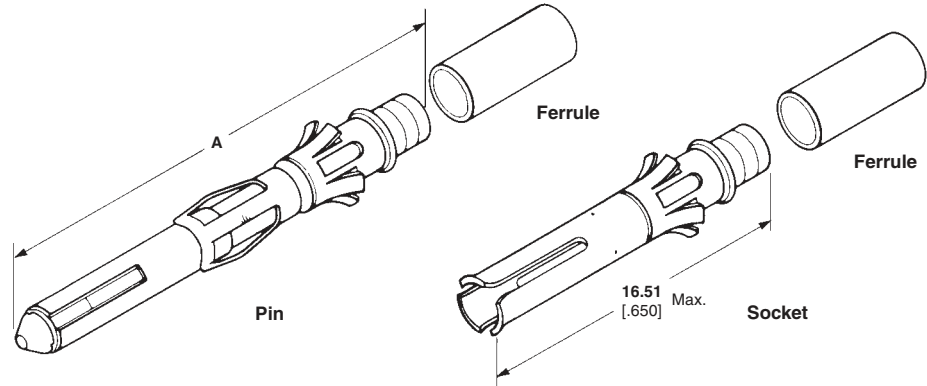

**A** = Multimate Pin **25.65** [1.010]  
Short Pin **22.66** [.892]

### Selection Chart for Coaxial Cable

RG/U Cable	Integral Die Hand Tool	PRO-CRIMPER	Die Insert for Tools: Hand Tool 69710-1 Pneu. Tool 69365-2, 69365-3*	Contact Part Numbers			
				Multimate Pin	Short Pin	Socket	Ferrule
178, 178A, 178B 196, 196A	69656-2		69690-2	<b>226537-2</b>	—	<b>51565-2</b>	1-332057-0
196 (Double Braid)	69656-9		—	<b>226537-2</b>	—	<b>51565-2</b>	225088-1
174, 316 188, 188A	—	91911-3	69690	<b>226537-1</b>	—	<b>51565-1</b>	1-332056-0
179, 179A, 179B 187, 187A Belden 9221	—	91911-4	69690-1	<b>226537-1</b>	—	<b>51565-1</b>	1-332056-0
RD-316	69656-7		—	<b>226537-1</b>	—	<b>51565-1</b>	225088-3
187 (Double Braid)	69656-8		—	<b>226537-1</b>	—	<b>51565-1</b>	225088-1
161	69656-5		—	<b>226537-1</b>	—	<b>51565-1</b>	1-332056-0

### Selection Chart for Twisted Pairs and Shielded Wire

Wire Size AWG	[mm <sup>2</sup> ]	Integral Die Hand Tool	PRO-CRIMPER	Die Insert for Tools: Hand Tool 69710-1 Pneu. Tool 69365-2, 69365-3*	Contact Part Numbers			
					Multimate Pin	Short Pin	Socket	Ferrule
30 (Twisted Pair, Solid)	0.05	69656-2	—	69690-2	<b>226537-3</b>	<b>51563-3</b>	<b>51565-3</b>	1-332057-0
28 (Twisted Pair, Solid)	0.08-0.09	—	91911-3	69690	<b>226537-3</b>	<b>51563-3</b>	<b>51565-3</b>	1-332057-0
28 (Twisted Pair, Stranded; 7 str., .005 [0.13] Dia.)	0.08-0.09	—	91911-4	69690-1 or 69690-2	<b>226537-3</b>	<b>51563-3</b>	<b>51565-3</b>	1-332057-0
26 (Twisted Pair, Solid or Stranded; 7 str., .0063 [0.16] Dia.)	0.12-0.15	—	91911-3	69690	<b>226537-3</b>	<b>51563-3</b>	<b>51565-3</b>	1-332057-0
26 (Shielded, 0.75 [1.91] Max. O.D.)	0.12-0.15	69656-3	—	69690-3	<b>226537-1</b>	—	<b>51565-1</b>	1-332057-0

\*Includes bench mount and foot control.

Extraction Tool 305183

**Note:** A ferrule is required for each pin and socket.

**Note:** Part Numbers are RoHS compliant except: ♦ Indicates non-RoHS compliant.

## SIEMAX Connectors

### Applications

- Multiplex Systems
- Base Stations
- High Density Systems

### Product Facts

- Multi Coax Surface Mount
- Maximum packaging density
- Component placement on both sides of PCB
- Fully automated assembly (pick-and-place)
- Modular design

### Technical Data

- Interface: Series 1.0/2.3
- Impedance: 75Ω
- International specifications: IEC 169-29 and CECC 22 230
- Frequency range up to 2 GHz
- Compact grid pitch 10 [0.39]
- Guaranteed coplanarity of max. 0.1 [0.004]
- Integrated positioning pins for manual placement
- Optional mechanical securing



SIEMAX connectors combine the benefits of surface mount technology and modular design. This multi coax connector is packaged in tape-and-reel for automatic placement, has optimum solder joints and 100% reflow suitability. This con-

necter is ideal for systems requiring superior packaging density because it can be placed on both sides of the printed circuit board.

The modular design provides flexibility in terms of the number of poles offered (two- or three-poles). It can

be stacked, enabling any required configuration to be produced. The SIEMAX connector also allows the use of any other connector series, e.g. SMB, is resistant to high temperatures, and is robust, with reliably sustained coplanarity.

For General Information  
on Series 1.0/2.3 Connectors, see  
Page 129.



**SIEMAX Connectors, Series 1.0/2.3 (75 Ohm)**

**SIEMAX Connector, SMT Right-Angle Jack, 2 Poles**

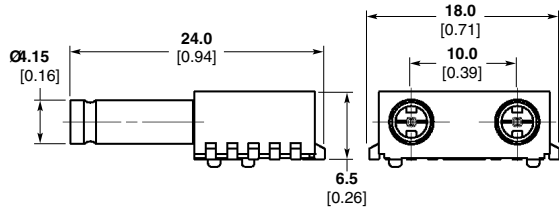

Coupling type*	Part No.
C, F	6-1393696-2

\*For coupling type see DIN 1.0/2.3 Section.

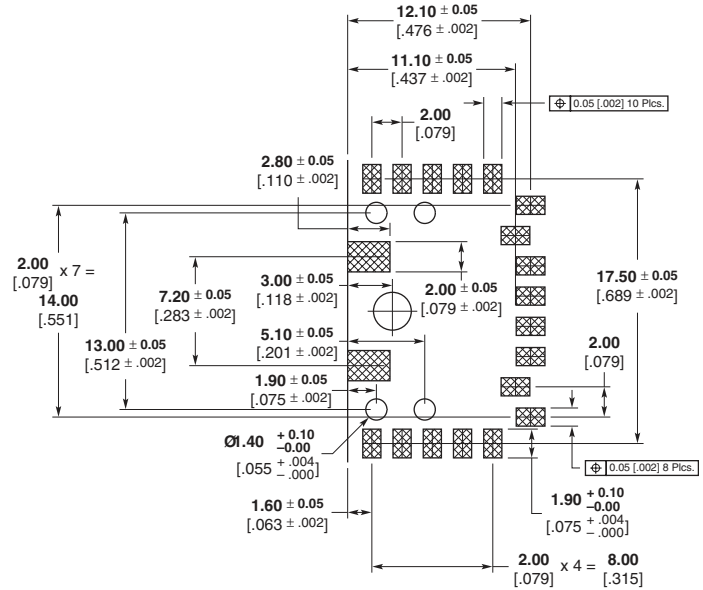

PC Board Layout

**SIEMAX Connector, SMT Right-Angle Jack, 3 Poles**

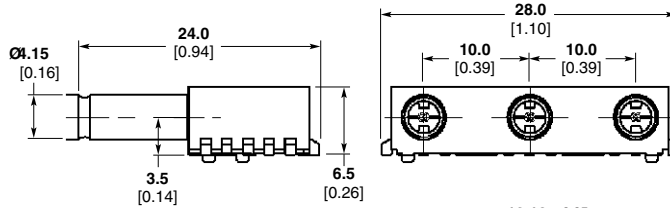

Coupling type*	Part No.
C, F	6-1393696-7

\*For coupling type see DIN 1.0/2.3 Section.

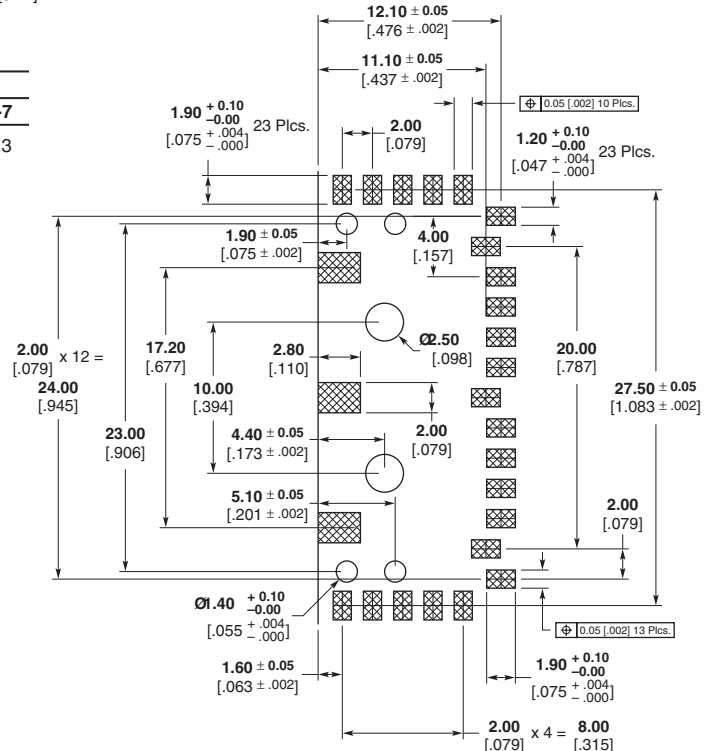

PC Board Layout

**Note:** Part Numbers are RoHS compliant except: ♦ Indicates non-RoHS compliant.

## Between Series Adapters

Between Series Coaxial Transmission Line Adapters provide convenient transitions between popular series coaxial connectors. The adapter design provides a minimum length consistent with good electrical performance. The small size, low VSWR, and broad frequency coverage permits a wide range of applications in both measurement and systems use.

### Design and Construction

The standard units are constructed of stainless steel with passivated finish, nickel plated brass, and gold plated brass. The material and plating is to be consistent with the basic connector series. All dielectrics are TFE fluoro-carbon. The center contacts are made of beryllium copper, gold plated.

### Types

The straight in-line adapters are available in many combinations of plug and jack (male and female) configurations. Also, popular panel mount versions are cataloged. For special modifications and hermetic seal version, consult Tyco Electronics.

### Application

The major application is the requirement for a low VSWR, compact transition in both test system and operating systems. Many panel mount and bulkhead mount versions are available so the designer can use small size connectors for internal design, but adapt to a larger rugged version for external connection.

Selection charts follow to help you find the correct adapter for your application.

### Plug-Plug

	N Series	OSP	OSP Bulkhead	BNC	7-16	SMB	SMA	SMP	SSMT	Series 1.0/2.3	QMA
MCX							Page 253				
N Series					Page 253						
BNC						Page 253					
Series 1.6/5.6				Page 253						Page 253	
SMA/SMA 18 GHz	Page 253	Page 253	Page 253			Page 253		Page 253	Page 253		Page 253

### Jack-Jack

	MCX	N Series N Series Flange Mount N Series Bulkhead	OSP OSP Bulkhead OSP Floating Rear Mount	BNC Bulkhead	TNC TNC Flange Mount TNC Bulkhead	7-16	SMB SMB 75 OHM SMB	SMP	SSMT	Series 1.0/2.3	Series 1.6/5.6
N Series						Page 254					
BNC							Page 254				Page 256
TNC		Page 254		Page 254							
SMA SMA Bulkhead SMA 18 GHz	Page 254	Page 254 and 255	Page 255 and 256	Page 254	Page 254 and 255		Page 255	Page 255	Page 255		
Series 1.0/2.3											Page 256

**Between Series Adapters** (Continued)

**Jack-Plug**

	7 mm	7 mm best VSWR	MCX	N Series N Series Flange Mount	OSP OSP Bulkhead	BNC	TNC	SMB	SMA SMA Flange Mount SMA 18 GHz	SMP	SSMT	DIN-Series 1.0/2.3	DIN-Series 1.6/5.6	UMCC
7 mm				Page 256	Page 256		Page 256		Page 256					
7 mm best VSWR				Page 256			Page 256							
MCX									Page 256					
N Series N Series Flange Mount	Page 256	Page 257				Page 257	Page 257		Page 257					
OSP OSP Bulkhead	Page 257								Page 257					
BNC				Page 257				Page 257	Page 257				Page 259	
TNC TNC Flange Mount	Page 258	Page 258		Page 258					Page 258					
SMB 75 OHM SMB				Page 259					Page 258					
SMA SMA Flange Mount SMA 18 GHz	Page 259		Page 258	Page 258 and 259	Page 260	Page 258	Page 259	Page 259		Page 259	Page 259			Page 259
SMP									Page 260					
SSMT									Page 260					
DIN-Series 1.0/2.3													Page 260	
DIN-Series 1.6/5.6						Page 259						Page 260		
QMA									Page 260					
UMCC									Page 260					

**Between Series Adapters** (Continued)

**Plug-Plug**

**MCX Plug – SMA Plug**

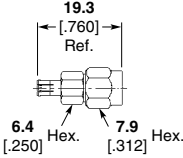

Part No. 1061071-1

**7-16 Plug – N Series Plug**

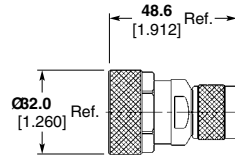

Part No. 1313453-1

**BNC Plug – SMB Plug**

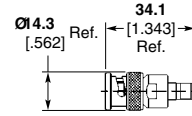

Part No. 1058066-1

**SMA 18 GHz Plug – N Series Plug**

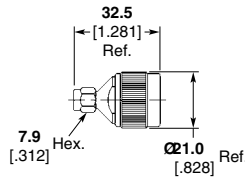

Part No. 1057367-1

**SMA Plug – SMB Plug**

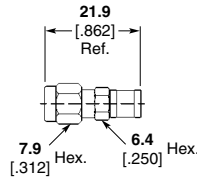

Part No. 1060494-1

**SMA Plug – SMP Plug**

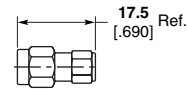

Part No. 1056706-1

**SMA Plug – SSMT Plug**

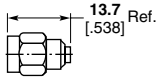

Part No. 1055695-1

**SMA Plug – OSP Plug**

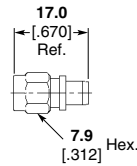

Part No. 1059711-1

**Series 1.6/5.6 Plug – Series 1.0/2.3 Plug**

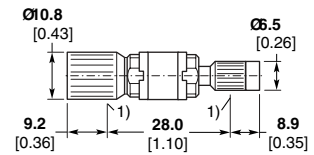

Part No. 2-1393670-1 ♦  
Coupling Type A  
1) Detent for jack

**BNC Plug – Series 1.6/5.6 Plug**

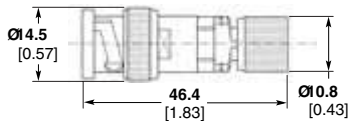

Part No. 1-1393665-4 ♦

**QMA Plug – SMA Plug**

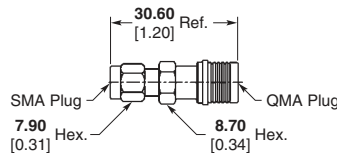

Part No. 1408393-1

**Note:** Part Numbers are RoHS compliant except: ♦ Indicates non-RoHS compliant.

**Between Series Adapters** (Continued)

**Jack-Jack**

**7-16 Jack – N Series Jack**

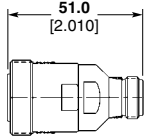

Part No. 1311206-1

**BNC Jack – SMB Jack**

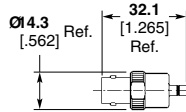

Part No. 1058056-1

**BNC Jack – 75 ohm SMB Jack**

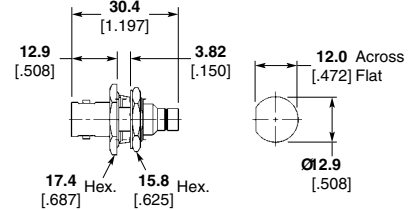

Part No. 1311209-1

**TNC Jack – N Series Flange Mount Jack**

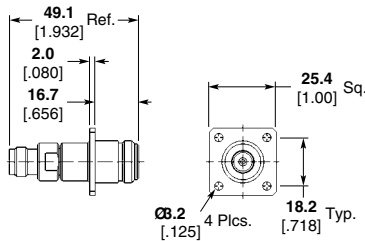

Part No. 1057843-1

**TNC Jack – BNC Jack**

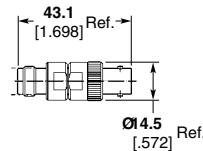

Part No. 1057845-1

**MCX Jack – SMA Jack**

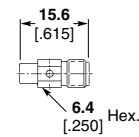

Part No. 1061070-1

**SMA Jack – N Series Jack**

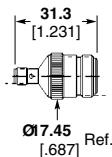

Part No. 1057341-1

**SMA Jack – N Series Flange Mount**

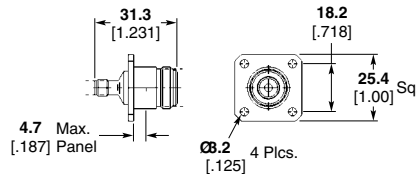

Part No. 1057343-1

**SMA Jack – N Series Bulkhead Jack**

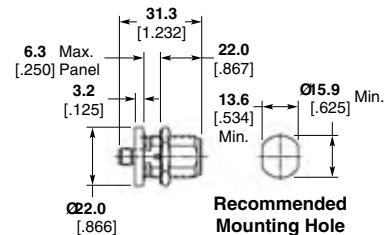

Part No. 1057463-1

**SMA Jack – BNC Jack**

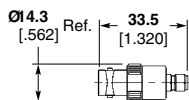

Part No. 1058058-1

**BNC Bulkhead Jack – SMA Jack**

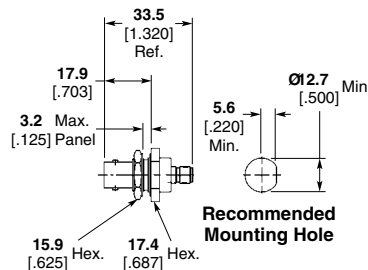

Part No. 1058117-1

**TNC Flange Mount Jack – SMA Jack**

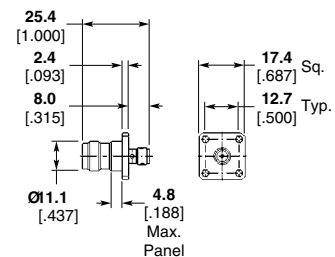

Part No. 1057841-1

**Note:** Part Numbers are RoHS compliant except: ♦ Indicates non-RoHS compliant.

**Between Series Adapters (Continued)**

**Jack-Jack (Continued)**

**SMA Jack – TNC Bulkhead Jack**

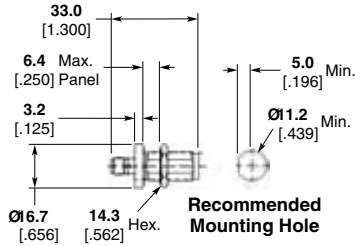

Part No. 1057908-1

**SMB Jack – SMA Jack**

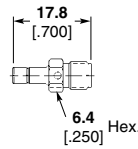

Part No. 1060487-1

**SMA Jack – SMP Jack**

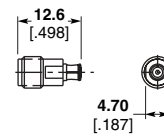

Part No. 1056702-1

**SMA Jack – SSMT Jack**

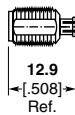

Part No. 1055694-1

**OSP Jack – SMA Bulkhead Jack**

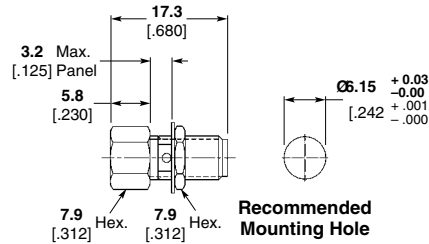

Part No. 1059733-1

**SMA 18 GHz Jack – N Series Jack**

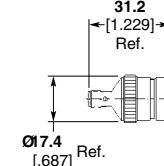

Part No. 1058651-1

**SMA 18 GHz Jack – N Series Flange Mount Jack**

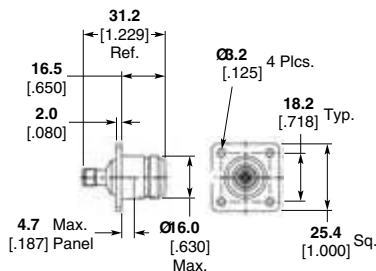

Part No. 1058653-1

**SMA 18 GHz Jack – N Series Bulkhead Jack**

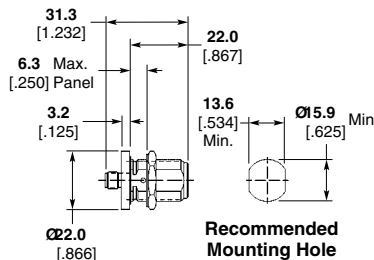

Part No. 1058675-1

**OSP Jack – SMA Jack**

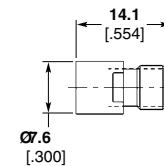

Part No. 1059707-1

**SMA Jack – OSP Bulkhead Jack**

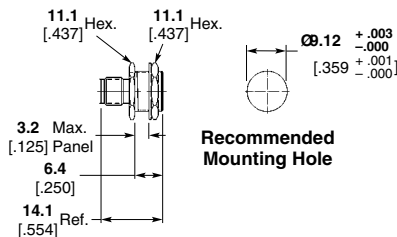

Part No. 1059729-1

**OSP Floating Flange Mount Jack – SMA Jack**

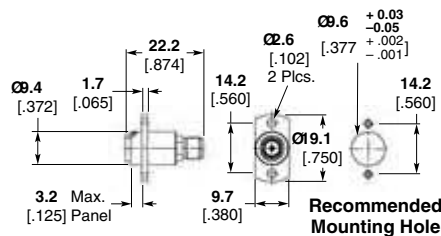

Part No. 1059731-1

**SMA Jack – OSP Floating Rear Mount Jack**

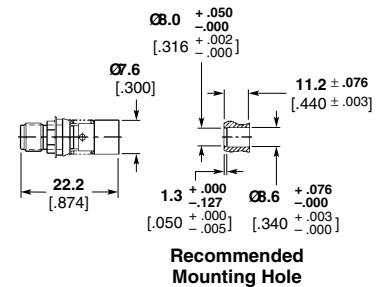

Part No. 1059724-1

**Note:** Part Numbers are RoHS compliant except: ♦ Indicates non-RoHS compliant.

**Between Series Adapters** (Continued)

**Jack-Jack** (Continued)

**BNC Jack –  
Series 1.6/5.6 Jack**

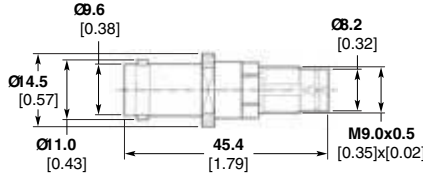

Part No. 1-1393665-♦

**Series 1.0/2.3 Jack –  
Series 1.6/5.6 Jack**

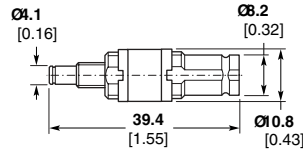

Part No. 2-1393670-♦  
Coupling Type A, B, F

**Jack-Plug**

**N Series Plug to 7 mm Jack**

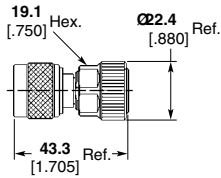

Part No. 1061742-1

**OSP Plug to 7 mm Jack**

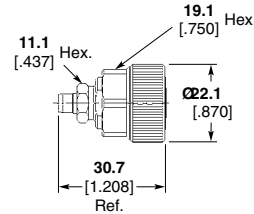

Part No. 1059713-1

**TNC Plug to 7 mm Jack**

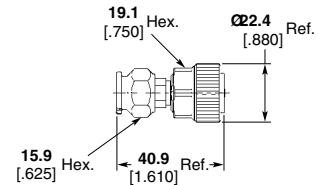

Part No. 1061739-1

**SMA Flange Mount Plug to 7 mm Jack**

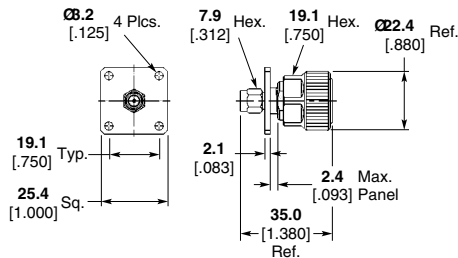

Part No. 1061751-1

**SMA Plug to 7 mm Jack**

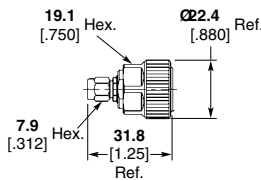

Part No. 1053646-1

**N Series Plug to 7 mm Best VSWR Jack**

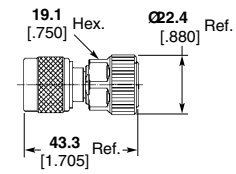

Part No. 1061738-1

**TNC Plug to 7 mm Best VSWR Jack**

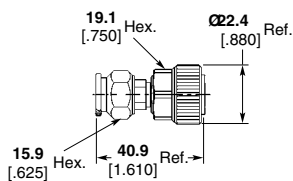

Part No. 1061744-1

**MCX Jack – SMA Plug**

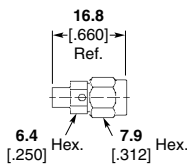

Part No. 1061073-1

**N Series Jack – 7 mm Plug**

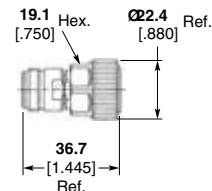

Part No. 1061757-1

**Note:** Part Numbers are RoHS compliant except: ♦ Indicates non-RoHS compliant.

**Between Series Adapters** (Continued)

**Jack-Plug** (Continued)

**N Series Jack – 7 mm Best VSWR Plug**

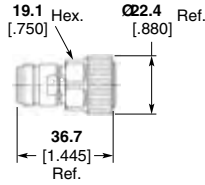

Part No. 1061752-1

**BNC Plug – N Series Jack**

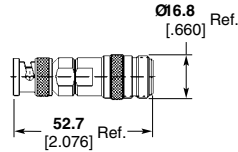

Part No. 1057392-1

**N Series Jack – TNC Plug**

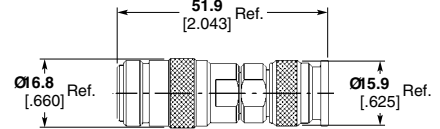

Part No. 1057388-1

**SMA Plug – N Series Jack**

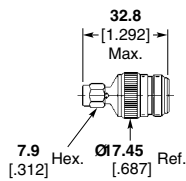

Part No. 1057381-1

**SMA 18 GHz Plug – N Series Jack**

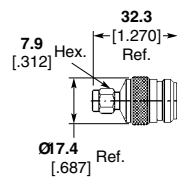

Part No. 1058664-1

**SMA Plug – N Series Flange Mount Jack**

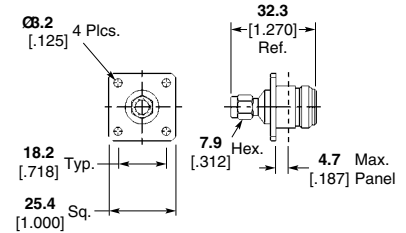

Part No. 1057385-1

**OSP Jack – 7 mm Plug**

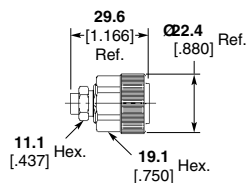

Part No. 1059720-1

**SMA Plug – OSP Jack**

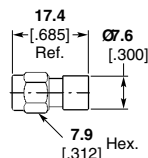

Part No. 1059718-1

**SMA Plug – OSP Bulkhead Jack**

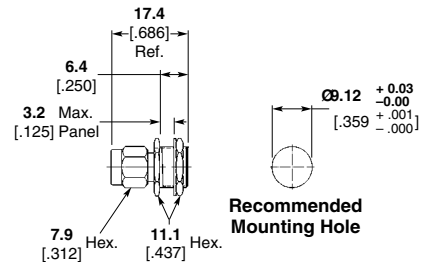

Part No. 1059758-1

**BNC Jack – N Series Plug**

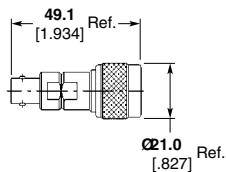

Part No. 1057390-1

**BNC Jack – SMB Plug**

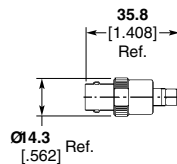

Part No. 1058077-1

**SMA Plug – BNC Jack**

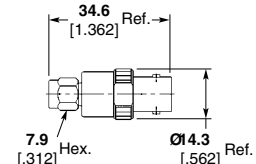

Part No. 1058083-1

**Note:** Part Numbers are RoHS compliant except: ♦ Indicates non-RoHS compliant.



**Between Series Adapters** (Continued)

**Jack-Plug** (Continued)

**TNC Jack – 7 mm Plug**

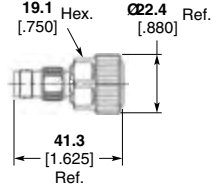

Part No. 1061753-1

**TNC Jack – 7 mm Best VSWR Plug**

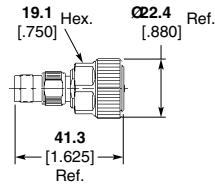

Part No. 1061758-1

**TNC Jack – N Series Plug**

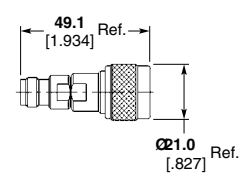

Part No. 1057387-1

**TNC Flange Mount Jack – SMA Plug**

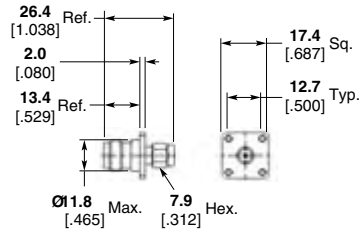

Part No. 1057857-1

**SMA Plug – SMB Jack**

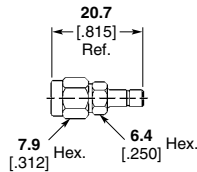

Part No. 1060500-1

**SMA Jack – MCX Plug**

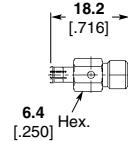

Part No. 1061072-1

**SMA 18 GHz Jack – N Series Plug**

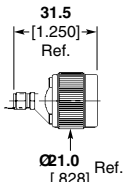

Part No. 1057377-1

**SMA Jack – BNC Plug**

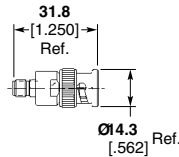

Part No. 1058081-1

**TNC Plug – SMA Jack**

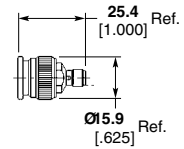

Part No. 1057853-1

**SMA Jack – SMB Plug**

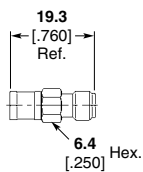

Part No. 1060498-1

**SMA Jack – SMP Plug**



Part No. 1056707-1

**SMA Jack – SSMT Plug**

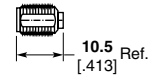

Part No. 1055696-1

**Note:** Part Numbers are RoHS compliant except: ♦ Indicates non-RoHS compliant.

**Between Series Adapters (Continued)**

**Jack-Plug (Continued)**

**SMA Jack – UMCC Plug**

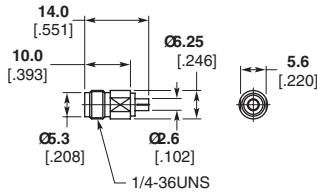

Part No. 1775229-1

**SMA Jack – UMCC Plug**

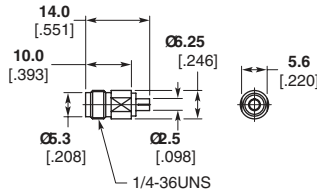

Part No. 1775230-1

**SMA Flange Mount Jack – 7 mm Plug**

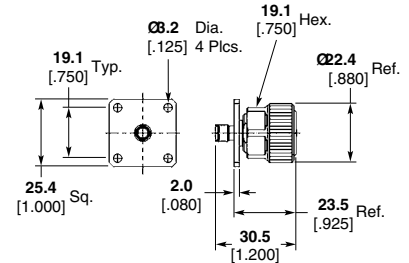

Part No. 1061750-1

**SMA 18 GHz Jack – 7 mm Plug**

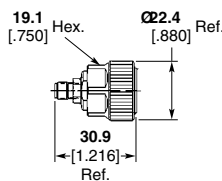

Part No. 1053788-1

**N Series Flange Mount Plug – SMA 18 GHz Jack**

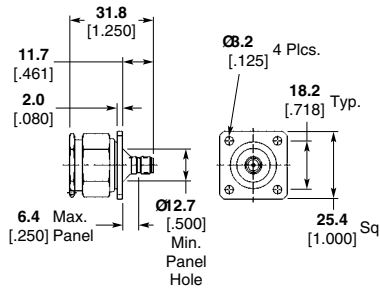

Part No. 1058666-1

**OSP Plug – SMA Jack**

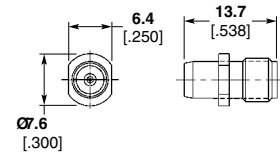

Part No. 1059716-1

**SMA 18 GHz Jack – OSP Bulkhead Plug**

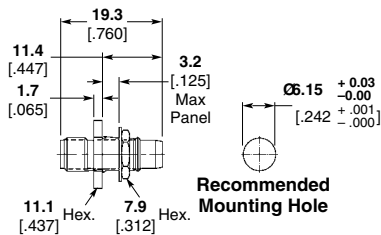

Part No. 1059756-1

**SMP Jack – SMA Plug**

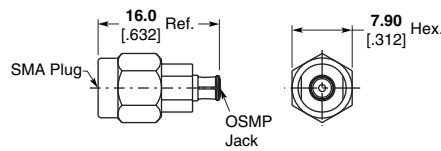

Part No. 1056708-1

**SSMT Jack – SMA Plug**

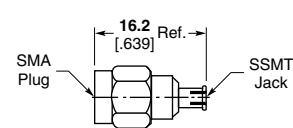

Part No. 1055697-1

**BNC Jack – Series 1.6/5.6 Plug**

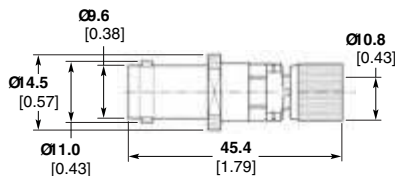

Part No. 1-1393665-7 ♦

**BNC Plug – Series 1.6/5.6 Jack**

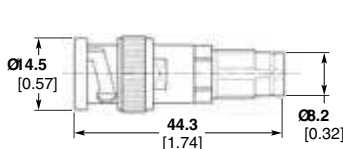

Part No. 1-1393665-6 ♦

**Series 1.6/5.6 Plug – Series 1.0/2.3 Jack**

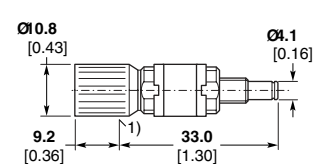

Part No. 2-1393670-2 ♦  
Coupling Type A, B<sup>2</sup>, F<sup>2</sup>

**Note:** Part Numbers are RoHS compliant except: ♦ Indicates non-RoHS compliant.

**Between Series Adapters** (Continued)

**Jack-Plug** (Continued)

**Series Plug 1.0/2.3 – Series 1.6/5.6 Jack**

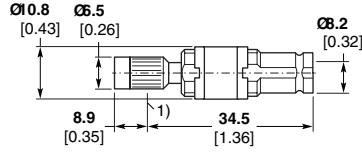

**Part No. 2-1393670-3** ♦  
Coupling Type A, B<sup>2</sup>, F<sup>2</sup>

- 1) Detent for jack
- 2 Only jackside

**QMA Jack – SMA Plug**

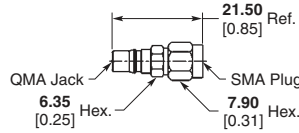

**Part No. 1408343-1**

**UMCC Jack – SMA Plug**

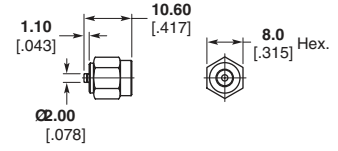

**Part No. 1775228-1**

**UMCC Jack – SMA Plug**

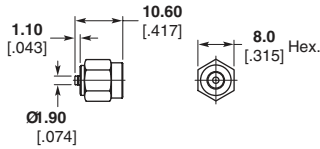

**Part No. 1775227-1**

**Note:** Part Numbers are RoHS compliant except: ♦ Indicates non-RoHS compliant.

**Coaxial Terminations**

**SMA Plug Terminator**  
**Part Number 1460802**

**Plating** — Gold  
**Frequency** — 6 GHz

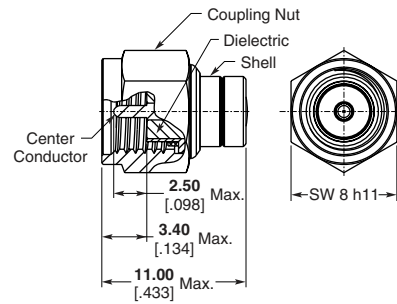

**SMC Plug Terminator**  
**Part Number 1460803**

**Plating** — Gold  
**Frequency** — 6 GHz

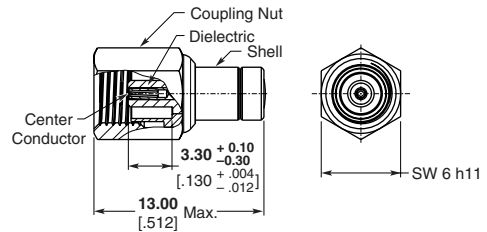

**Push Pull Plug Terminator**  
**Part Number 619219**

**Plating** — Gold  
**Frequency** — 6 GHz

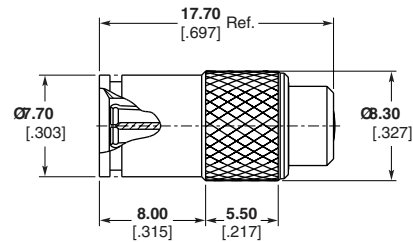

**QMA Plug Terminator**  
**Part Number 619271-1**

Single Packaging  
**Plating** — Standard Gold

**Part Number 5-619271-1**  
1000 Pieces per Pack

**Plating** — Standard Gold

**Part Number 619271-2**

Single Packaging  
**Plating** — Higher Gold

**Part Number 5-619271-2**

1000 Pieces per Pack  
**Plating** — Higher Gold

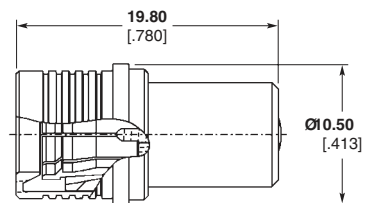

**Note:** Part Numbers are RoHS compliant except: ♦ Indicates non-RoHS compliant.

## Application Tooling

### Installation Kit Part No. 1055469-1 For TNC Connectors



For installation of TNC Series connectors to 3.66 [.141] and 2.16 [.085] diameter semi-rigid cable. Most BNC Series connectors can also be assembled using this kit. See appropriate assembly procedure for specific tooling. This kit contains:

Description	Model No.	NSN	Part No.
Center Contact Holder	T-4580	—	1055474-1
Fixture Sub-Assembly	T-4567	—	1055439-1
Inserts – 2.16 [.085] (2)	T-4700-2	5120-00-132-6808	1055441-1
Inserts – 3.66 [.141] (2)	T-4700-1	5120-00-132-6807	1055440-1
Locator Tool	T-4596	—	1055476-1
Locator Tool	T-4574	—	1055477-1
Solder Gage .813 [.032]	T-4562-6	—	1055475-1

All Tools May Be Purchased Separately.

**Application Tooling** (Continued)

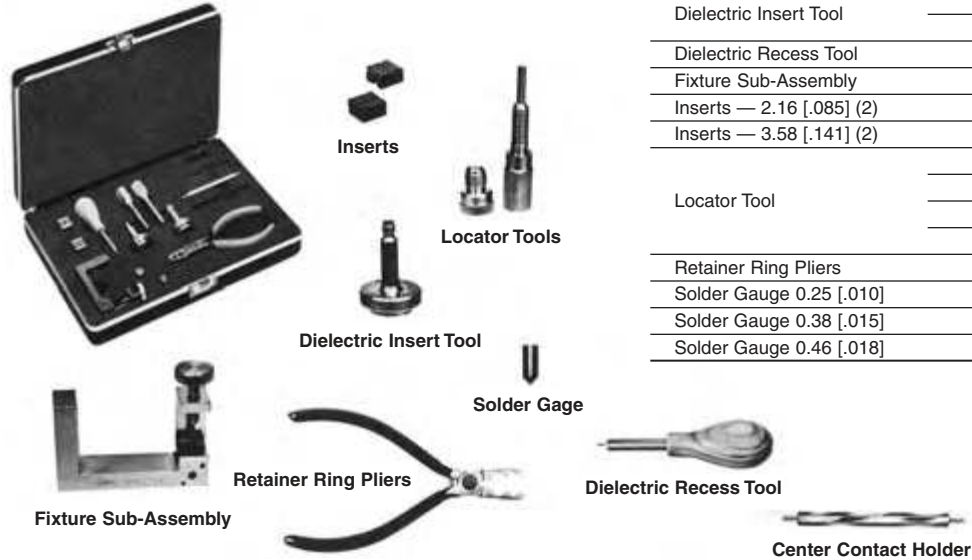
**Solder Assembly Kit  
Brass SMA Connectors**
**Kit Part Number 1055420-1**

Item Description	Part No.
Center Contact Holder	1055454-1
Dielectric Insert Tool	1055448-1
	1055447-1
Dielectric Recess Tool	1055450-1
Fixture Sub-Assembly	1055439-1
Inserts — 2.16 [.085] (2)	1055441-1
Inserts — 3.58 [.141] (2)	1055440-1
	1055442-1
Locator Tool	1055443-1
	1055446-1
	1055451-1
Retainer Ring Pliers	1055449-1
Solder Gauge 0.25 [.010]	1055500-1
Solder Gauge 0.38 [.015]	1055445-1
Solder Gauge 0.46 [.018]	1055444-1

**Universal Compression  
Crimp Tool**
**Kit Part Number 1055835-1**

Tyco Electronics Universal Compression Crimp Tool offers the ability to rapidly produce cable assemblies using solderless compression crimp connectors with semi-rigid cables. This universal assembly tool kit will attach SMA, OSP, N and TNC series connectors to 3.58 [.141], 2.16 [.085] and 6.35 [.250] cable quickly and consistently with excellent mechanical and electrical results.

The tool kit permits single hand assembly. Anvils and cable supports can be quickly changed. Crimp lengths can be adjusted from .025 [.001] to 25.4 [1.000] in increments of .025 [.001]. Sharp radius bends in cables are easily accommodated. The kit contains:



Description	Part No.
Crimp Frame	1055831-1
Calibration Gauge	1055832-1
3.58 [.141] Cable Support	1055833-1
2.16 [.085] Cable Support	1055834-1
SMA Plug Anvil	1055836-1
SMA Jack Anvil	1055837-1
Type N Plug Anvil	1055838-1
Type N Jack Anvil	1055839-1
TNC Plug Anvil	1055840-1
TNC Jack Anvil	1055841-1
OSP Plug Anvil	1055842-1
OSP Jack Anvil	1055843-1

All tools may be purchased separately.

**Application Tooling** (Continued)

**Crimping Tools**

Crimping tools are used for assembling coaxial connectors on coaxial cables. They can be applied particularly economically for small batch sizes.

The crimping dies are a fixed part of the crimping tools. Each tool is equipped with 2 or 3 different profiles. A total of 6 widths across flats are possible with 2 tools, whose hand lengths are adapted to the dimensions of the hexagon profiles. The tools can be distinguished at a glance by different colored handles.



Item	Width Across Flats of the Profile			Dim. L	Color of handles	Part No.
	1	2	3			
Crimping Tool	2.8 0.11	3.2 0.13	3.6 0.14	214.0 8.43	Green	1393524-4
Crimping Tool	2.8 0.11	5.4 0.21	4.5 0.18	260.0 10.24	Yellow	1393524-5

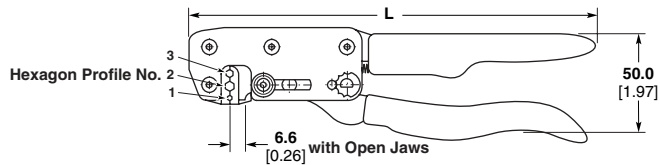

**IDC Tool**

For assembling IDC coaxial connectors Series 1.6/5.6 mS on coaxial cables.

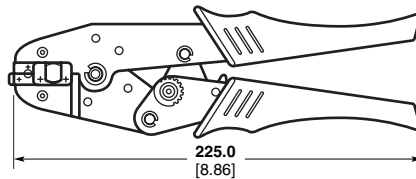

Part No.
1-1393524-1

**Removal Tool**

For replacing the special contacts on connectors DIN 41612 M and SIEDECON.

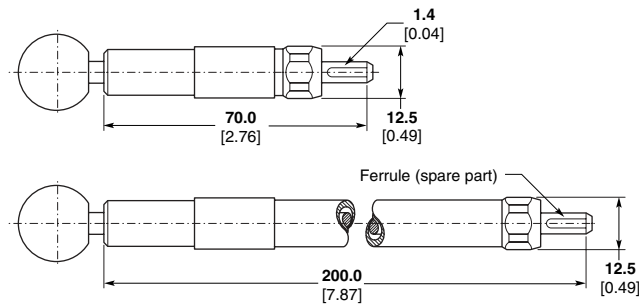

Item	Part No.
Removal tool length 70 [2.76]	2-1393524-4
length 200 [7.87]	2-1393524-6
Spare part Ferrule	2-1393524-7

**Application Tooling** (Continued)

**Setting Gauge**

**Protective Caps/Setting Gauges**

The setting gauges are used to position coaxial jacks and pre-mating high-current plugs on male connectors DIN 41612 M if the pins are flow-soldered into PC boards.

The gauges are held by clamping in connector body and protect the blade contacts.

The gauges provide protection

- during transport (if the male connectors have already been removed from the packaging),
- during assembly,
- against soiling,
- during soldering.

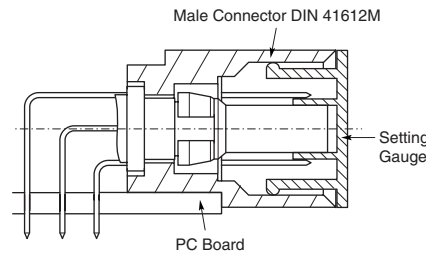

Item	Part No.
Setting gauge for types M	1393494-9
	M/2 1-1393494-0
	M/3 1-1393494-1

**Note:** These gauges can also be used to protect types C, C/2, C/3 and D.

**Wrench**

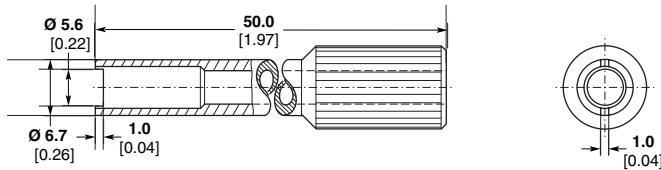

Used to tighten the threaded ring on bulkhead jacks Series 1.0/2.3

Item	Part No.
Wrench	1393488-3

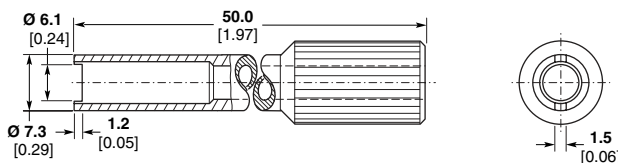

Used to tighten the threaded ring on bulkhead jack 1393670-8.

Item	Part No.
Wrench	1393488-4

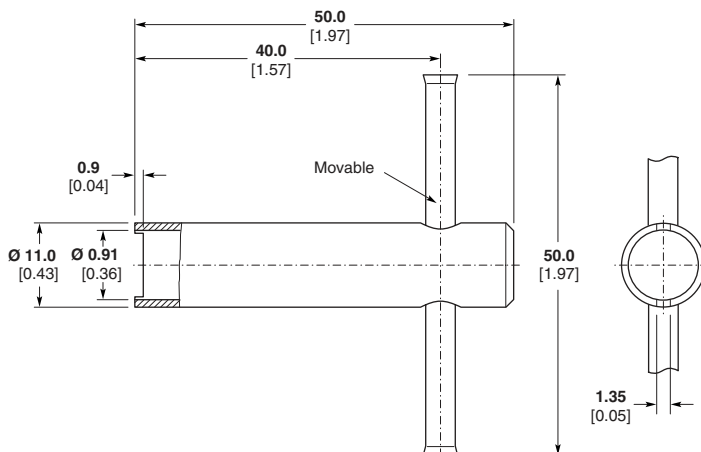

Used to tighten the threaded rings 1-1393562-0 on bulkhead jacks Series 1.6/5.6.

Item	Part No.
Wrench	1393524-1



**Application Tooling** (Continued)

**Hand Tools**

Tyco Electronics PRO-CRIMPER II Hand Tools are economy versions of our Tyco Electronics CERTI-CRIMP Hand Tools, featuring ratcheted crimp control to provide full die closure and help eliminate partial crimps. With an all new design, the PRO-CRIMPER II hand tools require dramatically less hand force to produce the same connection as comparable tools. Dies are interchangeable. It's the most versatile and reliable crimping tool in the mid-price class. Recommended for networking installations, and commercial, industrial and institutional maintenance work. See Catalog 82276 for further information.

**Typical PRO-CRIMPER III Hand Tool**



**No. 58433-1**  
for 50 Ohm BNC Dual  
"O" Crimp Commercial  
Connectors

Tyco Electronics CERTI-CRIMP Hand Tools are our top-of-the-line crimping tools featuring the original ratcheted crimp control. All tools are designed to exacting specifications, and manufactured using the highest quality materials to provide long service life. Recommended for low production runs, repairs and prototype work, and applications requiring consistent, highly-reliable terminations. See Catalog 65780 for further information.

**Typical CERTI-CRIMP Hand Tools with Integral (Non-Interchangeable) Dies**



**No. 69477-1**  
for 50 Ohm BNC  
Dual Crimp MIL Type  
Connectors



**No. 220015-1**  
for 50 Ohm N  
Connectors

**CERTI-CRIMP Hand Tool with Interchangeable Dies**



**No. 69710**

**Pneumatic Tools**

The 626 Pneumatic Tool System, as the name implies, will apply a broad range of products in the 6-26 AWG [13-0.12 mm<sup>2</sup>] wire range. A basic 626 Pneumatic Tool System requires a power unit, a tool holder, a crimp head assembly and a die set when applicable. This premium system is well suited for low- to medium- volume production and harness assembly operations. Since the crimp head can be rotated to any angle, the operator can also work on more difficult terminations in confined equipment cabinets or enclosures.

Interchangeable tool holder assemblies and crimping heads are available to crimp a variety of products. Crimping heads for the earlier Model 2614 pneumatic power unit can be used with the 626 Pneumatic Tool System. If you are already using Tyco Electronics hand tools, many crimp heads and die sets can be removed, attached to an adapter with quick pins and used with the 626 Pneumatic Tool System. An adapter is even available to accept lower cost die sets of the PRO-CRIMPER II hand tool. For more information, order catalog 124208.

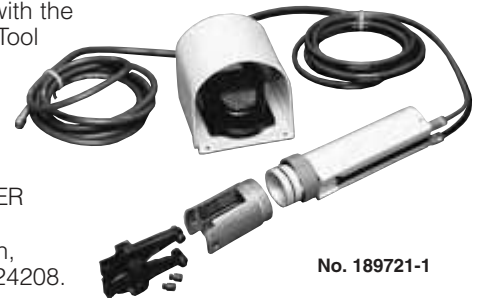

**No. 189721-1**

**Bench Mount Assembly for Pneumatic Tool System (Optional)**

Fully adjustable stand allows operator free use of both hands — recommended for maximum productivity.



**No. 856402-1**

**Battery Powered Crimp Tool**

Take automatic crimping away from the bench to the product, with this convenient, portable, battery-operated tool. It's at home in the factory or in the field.

- Completely portable—performs about 100 crimps per charge
- Terminates wires to 10 AWG [6 mm<sup>2</sup>]
- Weighs only 1.57 kg [3.46 lb] including battery; 360 mm [14.2 in] long
- Pressure-sensitive cycle control
- Kit includes tool, 2 batteries, and charger



**Part Number 1725837-1**  
**Part Number 1213890-1**  
**(Open Barrel)**

**Application Tooling** (Continued)

**Bench-Mounted Machines**

AMP-O-LECTRIC bench-mounted, semi-automatic terminating machines may be used to apply RF products such as Commercial BNC and TNC Connectors, Miniature and Standard UHF Connectors, and Braid-Pic Contacts and Terminals. The Model G unit features interchangeable applicators, and is used to apply strip-form contacts. The "Coax" unit is used to apply loose-piece contacts and ferrules with dies that are mounted onto the machine. See Catalog 65828 and Customer Manual 409-2627 for further information.

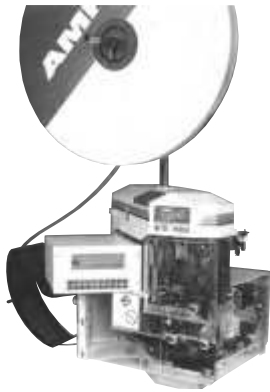

**AMP-O-LECTRIC Model G,  
No. 354500 Series with  
Tyco Electronics Crimp  
Quality Monitor**

**Stripping Tools**

The hand-operated Tyco Electronics Coaxial Cable Stripper features interchangeable, color-coded blade cassettes and V-blocks to accommodate 2- or 3-step stripping for cable diameters ranging from 2.54 [.10] through 7.62 [.30]. You strip cable by simply clamping and rotating the tool around the cable. See Instruction Sheet IS 2766 for further information.



For Use With Connector Type	Tool No.
BNC Single Crimp	603995-1
BNC Commercial and UHF Miniature	603995-2
UHF Standard	603995-3
BNC MIL Type Dual Crimp	603995-5
BNC Commercial Dual Crimp	603995-6

**Semi-Rigid Cable Tooling**

The tools listed here are designed specifically to strip and terminate semi-rigid cable. These tools operate basically the same as the flexible cable tools, in that they produce uniform terminations time after time, without heat damage from soldering.

**Hand Tool for BNC and TNC  
Semi-Rigid Cable Connectors**



**No. 59980-1 Frame only—  
does not include dies and locator**

**Application Tooling** (Continued)

**Hand Tool Kit for SMA and Blindmate Connectors**

No. 59981-1

**Pneumatic Tool for Terminating BNC, TNC, SMA and Blindmate Connectors**

(for RG 402/U and RG 405/U Cable)

No. 58318-1\*



This pneumatic tool is a bench-mounted, semi-automatic power tool designed for easy operation. The operator needs only to depress the trigger to complete a termination. It is used with the cable preparation machine to produce finished terminations.

\*Includes Locators 220241-1 and 308075-2. Dies are not included.

Item Description	Part Numbers	
	Tyco Electronics	Military (M22520/)
Hand Tool	59980-1	36-01
Plug Locator (without Center Contact)	220220-2	36-06
Plug Locator (with Center Contact)	220221-2	36-04
Jack Locator	220222-2	36-05
Die Set for RG 402/U Cable (3.58 [.141] O.D.)	312253-1	36-03
Die Set for RG 405/U Cable (2.18 [.086] O.D.)	312253-2	36-02
Cutoff Fixture	311395-1	36-09
Cable Dressing Fixture	311396-1	36-07
Trimmer Tool	312317-1	36-08
Cable Bend Fixture Assembly Includes following 6 items:	220224-1	36-10
Bend Segment, RG 402/U (3.18 [.125] Radius)	311386-1	36-11
Bend Segment, RG 402/U (6.35 [.250] Radius)	311386-2	36-12
Bend Segment, RG 405/U	311386-3	36-13
Tool Holder	311392-1	—
Limiting Pin	307581-1	—
Conforming Block	312067-1	—
Hex Wrench	21027-6	—
Carrying Case	13126-1	—
Insert, Case	13127-1	—

## Cable Assembly Capabilities



When your RF application demands a high performance cable assembly, make Tyco Electronics your advantage. We specialize in solving tough problems with assemblies designed and manufactured to the most demanding requirements. Why Tyco Electronics? Quite simply, because we can give you a comprehensive engineered solution to your application needs. By providing a precise match between cable, connector and application, we supply cable assemblies that meet your exact needs.

Every cable assembly application is unique.

A Tyco Electronics custom solution can be designed to meet your special requirements — whether these are related to return and insertion loss, propagation delay and phase matching, shielding and EMI, or special mechanical issues like density, latching, appearance, flexibility, or even weight. We approach your cable assembly individually, using the vast resources and knowledge gained from years of experience generating custom solutions. By making Tyco Electronics your partner in cable assembly design, you reduce risk and gain the assurance that you will receive assembly on time,

to specification and within your budget.

Tyco Electronics offers a wide range of RF/Coax Cable assemblies including 50 and 75 Ohm solutions, from micro-miniature UMCC and SSMT to high power assemblies using N-Series and DIN 7/16 connectors. Furthermore, we use a variety of cable types to meet unique requirements from standard military qualified RG cable to low loss foamed PE and PTFE tape wrapped cable as well as semi-rigid. Our engineering experts will find the right combination of materials to provide a solution that is cost effective.

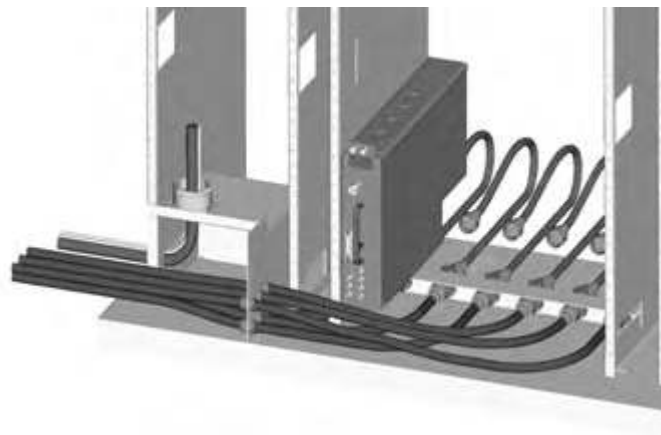

**Cable Assembly Capabilities (Continued)**



Utilizing network analyzers, TDR, and intermodulation test equipment to mention a few, our testing capability allows extensive electrical and environmental characterization of your assembly. We offer full test capabilities right in our manufacturing facilities. Tests such as those listed below can be

an integral part of the manufacturing process:

- VSWR,
- Return Loss,
- Insertion Loss,
- Phase matching,
- Propagation Delay,
- Impedance,
- Passive Intermodulation.

Our cable manufacturing centers are designed to meet your production requirements and delivery needs. Our global locations, combined with Tyco Electronics logistic strengths assures you will get the product where and when you need it.

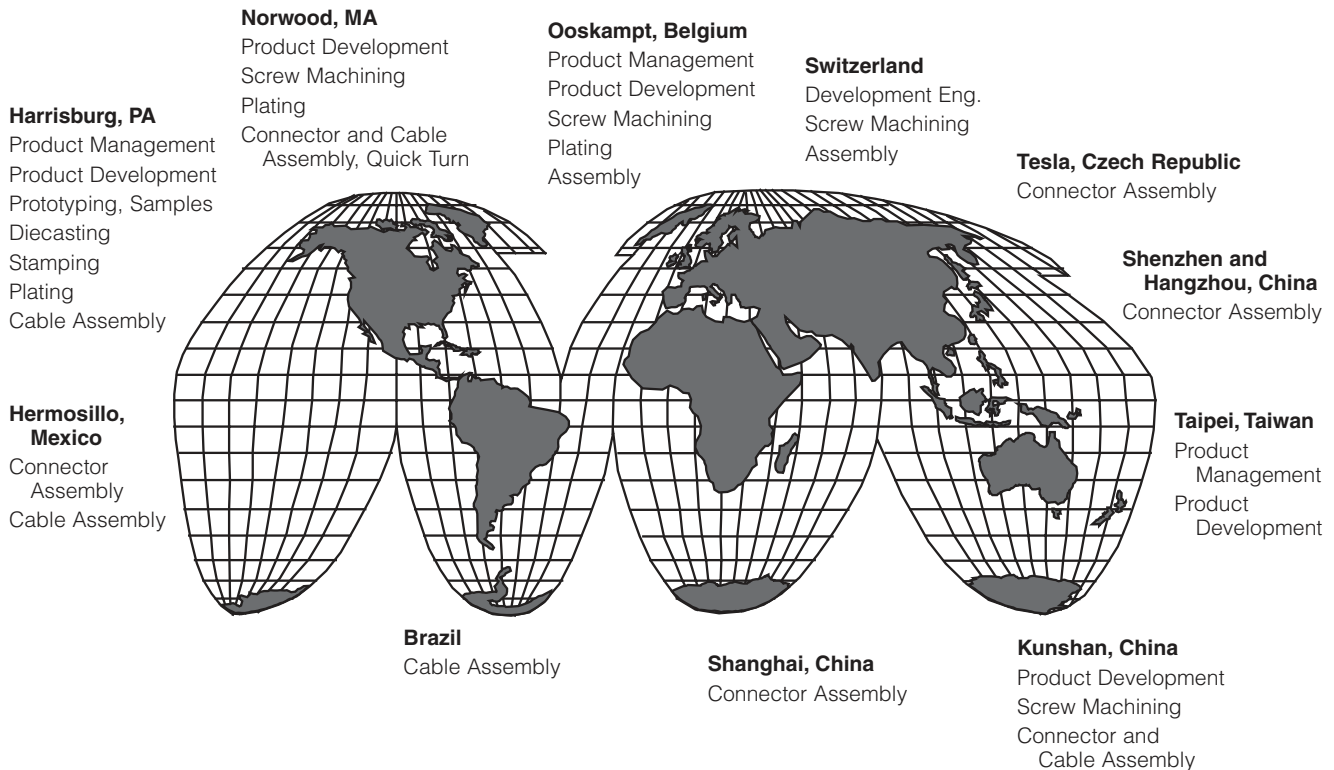

**Coaxial Cable Assembly Specification Guide**

Please use this handy reference guide when specifying or building your new cable assembly.

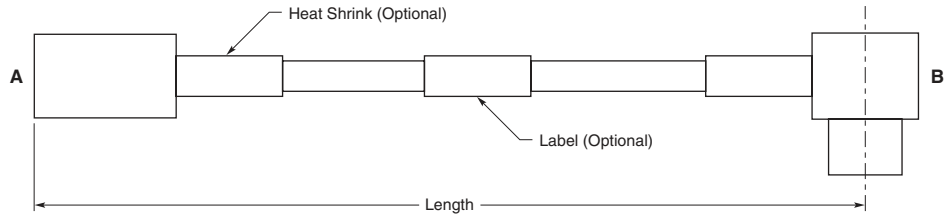

<p style="text-align: center;"><b>CONNECTOR A</b></p> <p>INTERFACE _____ example: BNC, MCX, SMA, etc.</p> <p>STYLE _____ example: Straight Plug, Right-Angle Plug, Bulkhead Jack, etc.</p> <p style="text-align: center;"><b>HEAT SHRINK</b> <input type="checkbox"/></p> <p>MARKING _____</p>	<p style="text-align: center;"><b>CONNECTOR B</b></p> <p>INTERFACE _____ example: BNC, MCX, SMA, etc.</p> <p>STYLE _____ example: Straight Plug, Right-Angle Plug, Bulkhead Jack, etc.</p> <p style="text-align: center;"><b>HEAT SHRINK</b> <input type="checkbox"/></p> <p>MARKING _____</p>
<p style="text-align: center;"><b>CABLE</b></p> <p>LENGTH _____ (inch/mm)</p> <p>RG TYPE _____</p> <p style="text-align: center;"><b>OR</b></p> <p>CABLE MFG. _____</p> <p>MFG. PART NO. _____</p> <p style="text-align: center;"><b>OR</b></p> <p>FREQUENCY RANGE _____ (MHz/GHz)</p> <p>IMPEDANCE _____ Ohms</p> <p>INSERTION LOSS _____ dB</p> <p>SHIELDING EFFECTIVENESS _____ dB</p> <p>TEMP. RANGE _____ (°C/°F)</p> <p>MAX. AVG. POWER HANDLING* _____ Watt * 25°C at sea level and max. specified frequency</p>	<p style="text-align: center;"><b>LABEL</b> <input type="checkbox"/></p> <p>MARKING</p> <div style="border: 2px solid black; padding: 10px; margin: 10px 0;"> <p>_____</p> <p>_____</p> <p>_____</p> </div> <p style="text-align: center;"><b>ELECTRICAL SPECIFICATIONS</b></p> <p>VSWR _____</p> <p style="text-align: center;"><b>OR</b></p> <p>RETURN LOSS _____</p> <p>INSERTION LOSS _____</p> <p>DELAY _____</p> <p>INSERTION PHASE _____</p> <p>INTERMODULATION _____</p>
<p>OTHER SPECIFICATIONS _____</p> <p>_____</p> <p>_____</p>	



**Appendix A - Theory and Application**

**Theory and Application**

As a leading manufacturer of RF products, Tyco Electronics produces a large variety of coaxial connectors. The proper selection and application of these connectors requires a knowledge of factors not involved in other types of connectors and terminals. The following paragraphs have been prepared to improve understanding of the theory behind RF connectors:

**Basic RF Theory<sup>1</sup>**

RF energy travels by electromagnetic waves, and it is primarily the frequency of these waves that we are interested in. Briefly, if an oscillating voltage source is connected to a cable, a continuous electromagnetic wave will propagate along the cable. A sensor placed at some point on the cable would indicate a varying voltage (E field) as well as a current and magnetic field (H field) as the wave travels past it. This is called an electromagnetic wave because both electric and magnetic fields are varying. The wave shape is initially determined by the variation of the source with time.

Figure 7 shows the radiant energy spectrum. Visible light, radio, television, x-rays and Gamma rays are all phenomenon of electromagnetic waves at different frequencies. This introduction will treat only those that are generated by an electrical source and propagated along a physical cable or other transmission media. That is, frequencies above zero and up to about 50 gigahertz.

<sup>1</sup>The majority of the technical terms, relative to RF and coaxial cable and connectors, used here-in and throughout this catalog are defined in the Glossary (Appendix G) starting on page 301.

Frequency or Wavelengths	Designation	Applications
0 - 29.9 KHz	VLF (Very Low Frequency)	Commercial AC electricity, deep depth sounders, ultrasonic grinders, sonic oscillators
30 - 299.9 KHz	LF (Low sonar Frequency)	Shallow-to-medium depth sounders
300 - 2999.9 KHz	MF (Medium Frequency)	Commercial AM radio broadcasting, marine radio telephone, direction finders
3 - 29.9 MHz	HF (High Frequency)	Citizen band radio, amateur radio, international broadcasting
30 - 299.9 MHz	VHF (Very High Frequency)	VHF television (Channels 2 thru 13), commercial FM radio broadcasting, amateur radio, fire and police radio
300 - 2999.9 MHz	UHF (Ultra-high Frequency)	UHF television (Channels 14 thru 83), microwave ovens, aeronautical radionavigation
3 - 29.9 GHz	SHF (Super High Frequency)	Microwave communications, marine radar, aircraft tracking and airborne radars
30 - 299.9 GHz	EHF (Extremely High Frequency)	Space communications, radio astronomy

**Notes:**

1. KHz = Kilohertz (1 thousand cycles per second)
2. MHz = Megahertz (1 million cycles per second)
3. GHz = Gigahertz (1 billion cycles per second)

**Figure 7**

**Radiant Energy Spectrum**

In the following paragraphs we will discuss waves in greater detail, including the relationship of frequency and wave length, how pulses are formed and used, how each differs from the other and the problems involved in their transmission.

**Sine Waves**

An RF wave is a sine wave, meaning that it smoothly swings from zero to a positive peak value, then back down past zero to a negative peak value, then back to zero to complete a 360 electrical degree cycle. The positive and negative peaks are always equal in amplitude. The two qualities which characterize this type of wave are amplitude and frequency (f). Figure 8 shows these two characteristics. Amplitude refers to the peak value attained by the wave and corresponds to voltage. Frequency refers to the number of oscillations per second. For example, the sign wave in Figure 8(B) has completed 12 cycles in one second. Therefore, we would say that this wave has a frequency of 12 cycles per second or 12 Hertz. The time for one complete cycle is defined as the period (T). The relationship between the period and frequency is given by the equation:

$$f = 1 / T \text{ in Hertz}$$

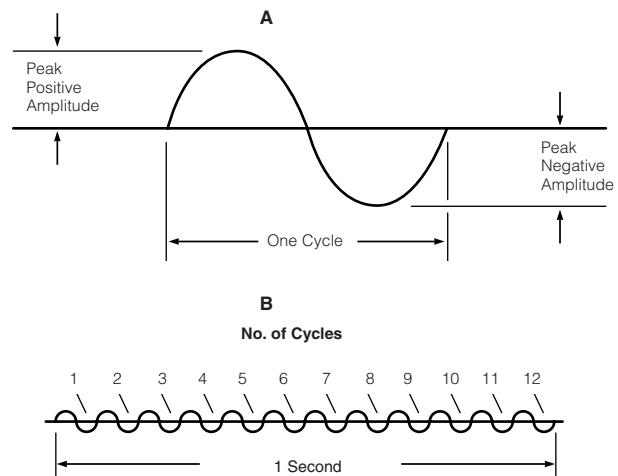

**Figure 8**

**Typical Sine Wave Characteristics**

The wave travels away from the generator at speeds approaching the speed of light. When an electromagnetic wave travels in a medium other than air or vacuum, the **speed** for the wave is reduced by a factor of the square root of the dielectric constant (ε). The velocity (v) of the propagation of a signal is given by:

$$v = \frac{c}{\sqrt{\epsilon}}$$

Where c is the speed of light, 3 x 10<sup>8</sup> m/sec or 1.18 x 10<sup>10</sup> in/sec, and ε is the dielectric constant of the medium. (See Table 1 for dielectric constants of various materials)

The **wavelength** of a signal is given by the formula

$$\lambda = v/f = \frac{c}{\sqrt{\epsilon} \times f \text{ (GHz)}} = \frac{1.18 \times 10^{10}}{\sqrt{\epsilon} \times f \text{ (GHz)}} \text{ inches}$$

See Figure 9

**Appendix A - Theory and Application** (Continued)

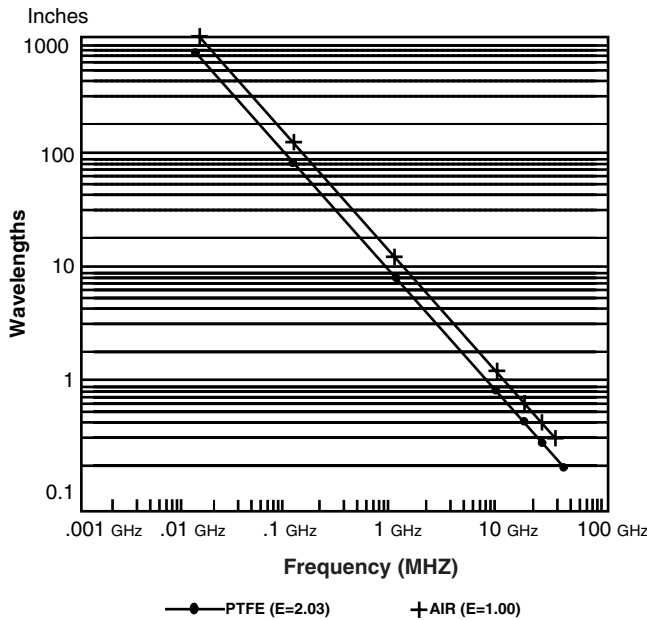

Figure 9

**Table 1. Properties of Insulating Materials**

Dielectric Material	Dielectric Constant	Operating Temperature Range
TFE	2.03	-70 +250°C
Polyethylene	2.3	-60 +80°C
Nylon	4.6-4.0	-40 +120°C
TPX	2.12	-65 +85°C
Polypropylene	2.25	-40 +105°C
Acetal	3.7	-65 +85°C

**Pulses**

The sine wave is most often used for communication purposes where intelligence is imposed on the wave by a variation in amplitude (amplitude modulation, AM) or by a variation in frequency (frequency modulation, FM).

Pulses, on the other hand, are primarily used in computers and digital instrumentation. Since pulses are generally used for triggering purposes, the pulse rise/fall time, amplitude and width are the most important. Figure 10 shows a pulse and identifies these characteristics.

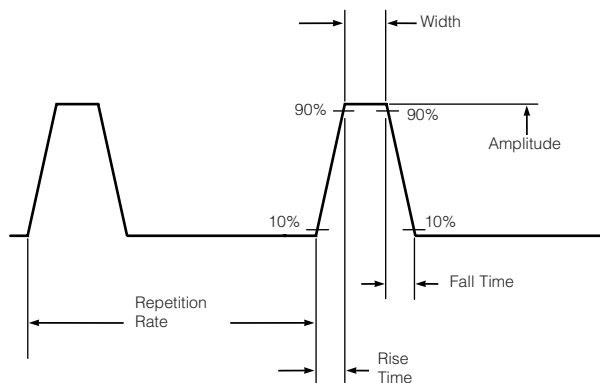

Figure 10

**Pulse Characteristics**

Notice that rise time is the time required for the pulse to rise from 10% to 90% of its amplitude - not from zero to maximum. Rise and fall time is perhaps the single most important characteristic of a pulse in today's high-speed digital equipment. Figure 11 shows that the faster the rise and fall time, the more pulses will fit in a given time frame.

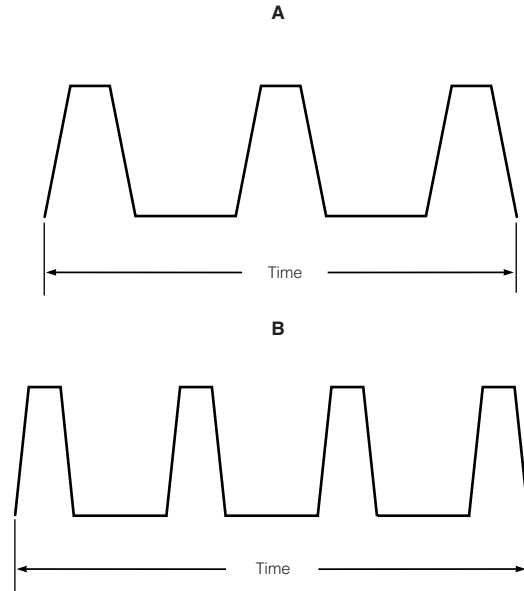

Figure 11

**Pulse Rise and Fall Time**

The bit rate for a system is the maximum rate of pulses per second that a system can process without causing data errors. The maximum performance can also be specified in terms of baud rate. The baud rate is defined as the number of characters (bytes) that are transmitted per second. Generally a character represents 10 bits (7 bits for the information, one parity bit, and two for start and stop, totalling 10).

Now that we know why fast pulses are required, the next problem is how to obtain faster rise times. A pulse is made up of a great number of different frequencies, and the more high frequencies a pulse contains, the faster will be its rise time and the flatter will be its peak. To better understand this, refer to Figure 12. At A, you will see a fundamental frequency (1), its third harmonic (3), and the resultant waveform (S3), which is a combination of 1 and 3. Although this does not yet resemble a square wave, you will note that the rise time is decreased, and a dip appears at the peak. At B of Figure 12, we have added the fifth harmonic. Rise time is further decreased, and the peak is beginning to flatten out. At C the seventh harmonic has been included, and the resultant wave S7 begins to resemble a square wave. As more high frequency harmonics are added to the waveform, it will more closely resemble a square wave, and the squarer it becomes, the faster will be the rise time.

TPX is a trademark of Mitsui Chemicals America, Inc.



**Appendix A - Theory and Application** (Continued)

Fast rise times and short pulse widths require high frequency components.

Two frequent causes of digital signal degradation can be (1) high capacitance of the transmission line and (2) impedance mismatches of connector transmission line or I/O devices. Selection of an impedance-matched connector on a digital line, especially if short cable assemblies are used, can be as important as connector selection for an RF modulated line. **Reflected pulses out of phase with the original pulse can cause false signals or high error rates in a digital system.**

Since pulses with fast rise times are necessary in high-speed computers, any circuit element which could reduce or attenuate high frequency response is undesirable.

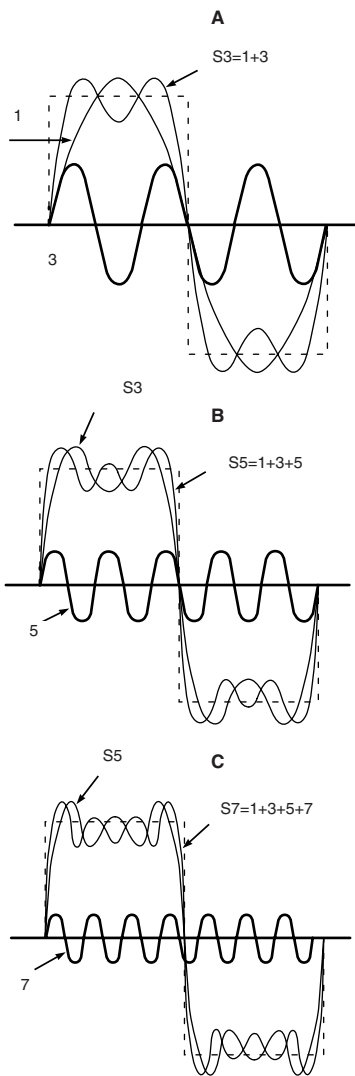

**Figure 12**  
**Development of a Square Wave**

**Signal Integrity and Propagation**

To explain how to maintain signal integrity, it is necessary to review how the signal is configured in a cable and how it propagates. Ignoring digital signals for this discussion we will identify the issues that deal with the integrity of a sine wave. Consider a coaxial cable consisting of an inner conductor surrounded by a dielectric material and then an outer conductor (See Figure 13). The outer conductor may be a braid, a foil, or a solid metal.

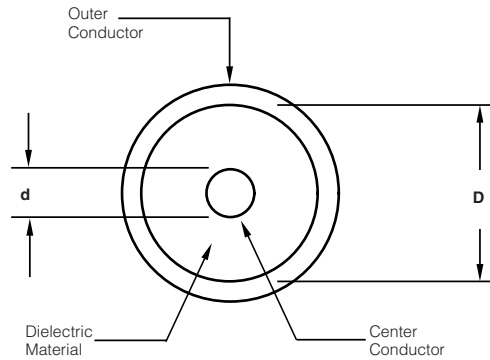

**Figure 13**  
**Diagram of a Cable**

An electromagnetic wave traveling in a coaxial cable produces an electric and a magnetic field between the inner conductor and the outer conductor (Figure 14). The electric (E field) is radial and varies in time. An alternating current flows along the inner conductor and the outer conductor. An oscillating magnetic field (H field) circles the inner conductor.

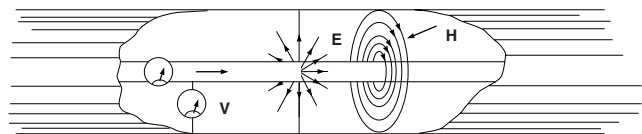

**Figure 14**  
**Electric field (E) and magnetic field (H) belonging to the principal mode in a coaxial line.**

The alternating current on a conductor is not spread throughout the conductor but is strongest at the surface and decays exponentially at points further into the conductor. This is called the skin effect. At a frequency of 1MHz, three skin depths is 0.0078" (95% of the current is within three skin depths of the surface) and at 10GHz three skin depths is 0.00078". As a result, the current is on the outer surface of the inner conductor and the inner surface of the outer conductor over the entire range of interest for most RF systems. The dimensions and material beyond several skin depths have no effect on the wave; gold plated plastic will propagate as well as gold plated copper at sufficiently high frequencies.

**Appendix A - Theory and Application** (Continued)

**Attenuation**

A wave loses energy (attenuates) in several ways: (1) The resistance of the inner and outer conductors is small but can be significant over long lengths and will produce some heat. (2) The dielectric may be lossy; its resistance is high but not infinite, and some energy is lost. (3) Electromagnetic energy radiates at high frequencies; significant energy losses are caused by radiation of electromagnetic energy (the cable acts like an antenna). (4) Energy is reflected due to impedance mismatches. The combination of these four types of losses are referred to as the **insertion loss** of a transmission line system. Connectors have similar losses.

**Characteristic Impedance**

A parameter which defines the behavior of a cable, connector, or any propagating system is **Characteristic Impedance, Z<sub>0</sub>**. The characteristic impedance of a lossless cable is related to the inductance per unit length, L, and the capacitance per unit length, C, as follows:

$$Z_0 = \sqrt{L/C} \text{ in ohms}$$

The equivalent circuit of a transmission line is shown in Figure 15. R represents the conductor resistance for a unit length. For a coaxial cable the characteristic impedance is given by:

$$Z_0 = \frac{138}{\sqrt{\epsilon}} \times \text{Log}_{10} \frac{D}{d} \text{ in ohms}$$

where D is the inner diameter of the outer conductor and d is the outer diameter of the inner conductor, respectively. Similar equations apply for other geometries such as two parallel wires.

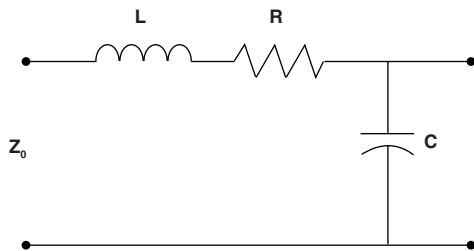

Figure 15

**Typical Transmission Line Schematic**

The maximum power is transferred between two systems if they have the same impedance. This is called impedance matching. However, impedance variations that are short compared to a wavelength can have a negligible effect on signal loss.

Standard impedances are 50 ohm, 75 ohm and 93-125 ohm. Most systems use 50 ohm because it is a compromise between maximum power transmission and minimum line loss. The telephone industry and the broadcast industry use 75 ohm for minimum line attenuation. The need for low capacitance instrumentation cable has produced the 93-125 ohm systems. The higher impedances are generally achieved by changing the conductor diameters and by modifying the dielectric material to add air.

**Reflections**

When the characteristic impedance changes in a transmission line system, part of an incident wave is reflected. The reflection coefficient can be calculated as:

$$\text{Reflection Coefficient} = \rho = \frac{V_i}{V_R} = \frac{Z_R - Z_0}{Z_R + Z_0}$$

Where V<sub>i</sub> and Z<sub>0</sub> are the incident voltage and impedance of the first media. V<sub>R</sub> and Z<sub>R</sub> represent the reflected voltage and impedance of the media that caused the reflection. The decibel loss due to reflection is given by:

$$\text{Return Loss} = 10 \text{ Log}_{10} \left( \frac{1}{1 - \rho^2} \right) \text{ dB}$$

**VSWR**

The traditional way to determine the reflection coefficient is to measure the standing wave caused by the superposition of the incident wave and the reflected wave. Traditionally the voltage is measured at a series of points using a slotted line. The ratio of the maximum divided by the minimum is the Voltage Standing Wave Ratio (VSWR). The VSWR is infinite for total reflections because the minimum voltage is zero. If no reflection occurs the VSWR is 1.0. VSWR and reflection coefficient are related as follows:

$$\text{VSWR} = (1 + \rho)/(1 - \rho)$$

Most present instrumentation measures the reflection coefficient and calculates the VSWR.

Figure 16 represents the direct relationship between VSWR and its equivalent in return loss (expressed in dB).

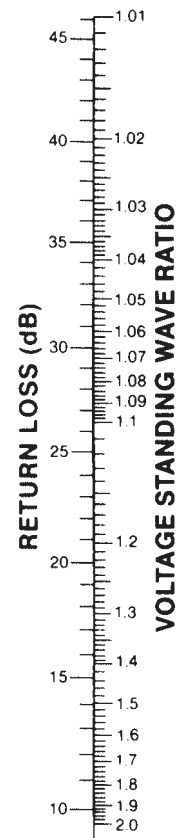

Figure 16

**VSWR vs. Return Loss**

**Multiple Reflections**

If there is a series of impedance changes, each one will have a reflection coefficient. The total reflection coefficient is the vector addition of each of the individual coefficients accounting for the distance between reflections and the reflection of any reflected waves. Even though the calculations are difficult, a total VSWR can still be measured.

Multiple reflections can produce a resonance phenomenon that is unique to wave theory. Properly understood some serious difficulties can be avoided. An example will make the point clear. Consider an electromagnetic wave with a

**Appendix A - Theory and Application** (Continued)

wavelength of 4 inches traveling on a cable that changes from 50 ohms to 25 ohms. The reflection coefficient is -.33, which means that one third of the incident voltage is reflected toward the source. Assume that one inch (one quarter wavelength) down the cable the impedance changes back to 50 ohm. Again, one third of the wave is reflected, but without any phase shift. It travels back to the first interface where one third of this reflected wave is reflected back toward the second interface. Two thirds of the wave is transmitted through the interface and travels back to the source. Since the first (reflected) wave is shifted 180 degrees at the reflection, and the second (transmitted-reflected-transmitted) wave is shifted 180 degrees because it traveled the one inch separation twice, the two waves are in phase. The net result is that the VSWR is much larger because the length of the 25 ohm section was just the right length to cause a resonance. If the length of the 25 ohm section had been one half wavelength, the two waves would have interfered and the VSWR would be at a minimum.

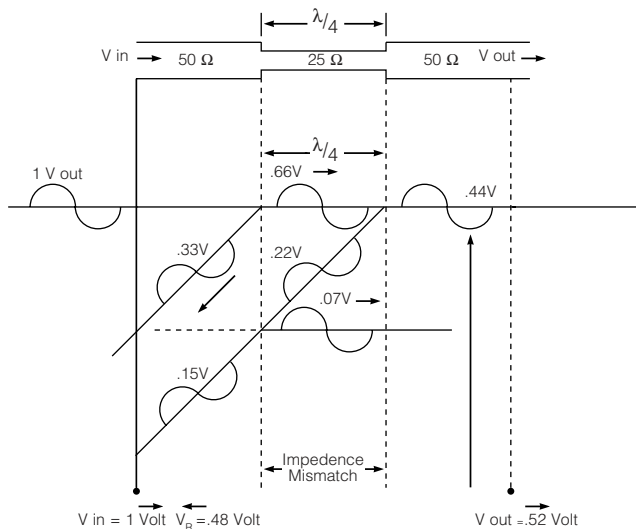

Figure 17

**Multiple Wave Reflections**  
(Caused by Impedance Mismatch)

In summary, avoid cable lengths, printed circuit board paths, or connectors that are multiple of one quarter ( $\lambda/4$ ,  $3\lambda/4$ , etc.) of the intended signal transmission wavelength. Coaxial cables, when manufactured, also have periodic variations in diameter that result in periodic changes in impedance ( $Z_0$ ), that can cause significant levels of reflected signal (high return loss) at specific frequencies.

**Reflections of Digital Signals**

The previous discussions dealing with attenuation, reflections and standing waves can apply to digital signals with some extra thought.

A single pulse can be thought of as a combination of high frequency sine waves. The maximum frequency component in a square wave pulse can be calculated by this equation:

$$f = 0.35/\text{rise time}$$

where

$$f = \text{GHz when "t" is in nanoseconds}$$

Attenuation of the frequencies necessary to support the short risetime will produce a slower rise and possibly prohibit the pulse from ever reaching the detector. This 'slurring' of the pulse is similar to the behavior of an RC circuit and the attenuation is sometimes called capacitive attenuation.

A series of pulses can demonstrate resonance. If a portion of a pulse is reflected at each interface, it is possible for them to come together and add up to form a new phantom pulse.

The critical frequency here is the bit rate. Think of a sine wave with a frequency the same as the bit rate; if it will resonate in the cable, the pulses will also. Extra pulses caused by resonance might easily result in an error signal from the receiving system requesting a retransmittal. The final result would be a communication system that is much slower than intended.

**Cut-off Frequency**

The cut-off frequency of a coaxial transmission line is the frequency at which modes of energy transmission, other than the "TEM" mode, can be generated.

$$f_{co} = \frac{7.5}{\sqrt{\epsilon} (D+d)} \text{ (in GHz)}$$

(D and d are measured in inches)

**Types of Transmission Lines**

**Twin Lead transmission cable** is generally used where impedance matching alone is important, since it provides only minimal shielding. Impedance values of 300 ohms and 600 ohms are common. Lower impedance values require closer spacing of the conductors and are not normally available in this type of cable. A typical application for twin lead cable is in antenna lead wire for television sets.

**Twisted Pair** is a variation of the twin lead type. It consists of two lengths of ordinary hookup wire twisted together. A twisted pair provides relatively constant impedance plus better magnetic shielding than twin lead cables. It is flexible, inexpensive, easy to terminate and is used extensively by the computer industry. However, it should not be used when maximum shielding is required.

**Appendix A - Theory and Application** (Continued)

**Shielded Twisted Pair Cable** is used to eliminate inductive and capacitive coupling. Twisting cancels out inductive coupling, while the shield eliminates capacitive coupling. Most applications for this cable are between equipment, racks and buildings.

**Flexible (Braided) Coaxial Cable** is by far the most common type of closed transmission line because of its flexibility. It is a coaxial cable, meaning that both the signal and the ground conductors are on the same center axis. The outer conductor is made from fine braided wire, hence the name "braided coaxial cable". This type of cable is used in practically all applications requiring complete shielding of the center conductor. The effectiveness of the shielding depends upon the weave of the braid and the number of braid layers. Tyco Electronics manufacturers connectors for cable sizes ranging from less than 1/8 in. diameter, for low power applications of around 50 watts, to over 1/2 in. diameter for power of 850 watts at 100 MHz and voltages up to 5000. In addition to power handling capabilities, cables are available for high frequency applications, high and low temperature applications, severe environmental applications and many other specialized uses.

**Triaxial Cable** is used when higher "shielding" efficiency characteristics are required in applications similar to those using shielded twisted pair cable.

Often you will hear the term "shielded cable". This is very similar to coaxial cable except the spacing between center conductor and shield is not carefully controlled during manufacture, resulting in non-constant impedance.

**Semirigid Coaxial Cable** uses a solid tubular outer conductor rather than the braided type, so that all the RF energy is contained within the cable. One of the drawbacks of braided cable is that the shielding is not 100% effective, especially at higher frequencies. This is because the braided construction can permit small amounts of short wavelength (high frequency) energy to radiate. Normally this does not present a problem; however, if a higher degree of shielding is required, semirigid coaxial cable is recommended. For applications using frequencies higher than 30 GHz a miniature semirigid cable is recommended. Various connectors are available from Tyco Electronics to terminate these cables.

**Ribbon Coaxial Cable** is a relatively recent Tyco Electronics innovation which combines the advantages of both ribbon cable and coaxial cable. Tyco Electronics currently provides both the cable and the insulation displacing coaxial connector to terminate the cable. Each individual coaxial cable consists of the signal conductor, dielectric, a foil shield and a drain wire which is in continuous contact with the foil. The entire assembly is then covered with an outer insulating jacket. The unique manufacturing feature of this cable is the precise placement of the drain wires to permit gang stripping of the outer jacket and foil. The major advantage of this cable is the speed and ease with which it can be mass terminated with the Tyco Electronics insulation displacement technique. They can also be separated into individual coaxial lines and terminated with standard coaxial connectors as required.

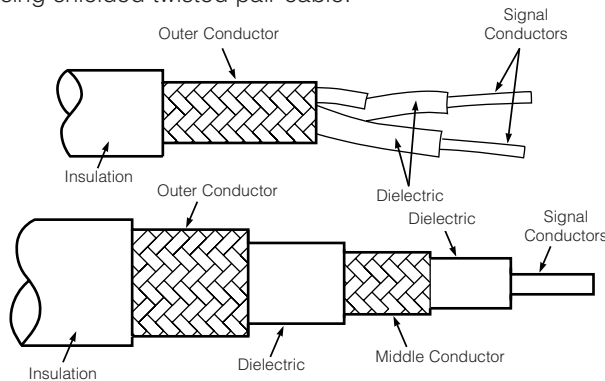

Figure 18

Twin Conductor and Triaxial Cable

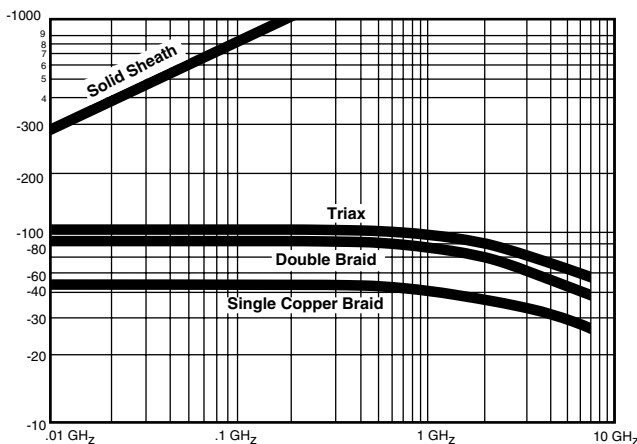

Figure 19

Shielding Efficiencies

## Appendix B - White Bronze

### High Quality Surface Plating & Excellent Intermodulation Performance for RF Connectors

#### Product Facts

- Low intermodulation
- High corrosion resistance
- Low porosity
- Low RF losses
- Wear and scratch resistance



Tyco Electronics' industrial electroplating facilities is one of the most advanced in the world.

#### Need more information?

Call Technical Support Center at 1-800-522-6752 for product and tooling information.

The Technical Support Center is staffed with specialists well versed in all Tyco Electronics products. The Center can provide you with:

- Engineering Support
- Catalogs
- Technical Documents
- Product Samples
- Tyco Electronics Authorized Distributor Locations
- Tyco Electronics Internet Home Page:  
[www.tycoelectronics.com](http://www.tycoelectronics.com)

The Tyco Electronics White Bronze surface finish represents a dramatic improvement upon the wear characteristics and life expectancy of silver plating, at the same time offering a far better electrical performance than nickel. White Bronze plated connectors exhibit intermodulation characteristics significantly better than stainless steel or nickel plated products. Silver has always been the preferred finish from an electrical standpoint but its corrosion and wear characteristics especially in harsh conditions are often unacceptable. While nickel is an extremely rugged finish it

has properties undesirable in many RF applications; including, high RF and insertion losses, poor intermodulation performance, high permeability and poor screening effectiveness.

The Tyco Electronics White Bronze is composed of copper, tin and zinc which are applied simultaneously to produce a finished color similar to stainless steel. With one of the most advanced industrial electroplating facilities in the world Tyco Electronics can achieve the levels of control over the complex galvanic process necessary in the application of this alloy.

The Tyco Electronics White Bronze is similar in composition and performance to other copper/tin/zinc alloys developed in the industry such as Sucoplate® and BBR.

Comprehensive conditioning tests have been performed to provide a thorough evaluation of The Tyco Electronics White Bronze plated connector bodies. The tests were performed to the specifications of the European and International RF connector standards — CECC 22000/IEC 68-2-14/IEC 169-1. The results are summarized on page 280.

#### Deposit Characteristics

**Composition** — Copper (55-60%), Tin (20-25%), Zinc (15-20%)

**Density** — 7.9-8.1 g/cm<sup>3</sup>

**Hardness** — 300-380 HV

**Passivation** — Immersion Chrome

Sucoplate® is a plating trademark for Huber & Suhner.  
BBR is a plating trademark for Radiall.



---

**Appendix B - White Bronze** (Continued)

---

**Low Intermodulation Products**

Dissimilar metals, finishes and discontinuities within a coaxial line structure give rise to Intermodulation Products (IMP). This is of particular concern in applications requiring low levels of intermodulation, such as cellular base stations and antennas. White Bronze plated connectors offer better IMP performance and lifetime characteristics than nickel. Due to the similarity of electrolytic potentials and the non magnetic properties of the finish, levels of intermodulation are commensurate with silver and far in excess of stainless steel/nickel connectors. At the same time the excellent wear characteristics and durability of the finish ensure that the intermodulation life of the connector is greater than silver. The life is also improved as a direct result of the excellent corrosion resistance properties of White Bronze; thereby minimizing metal/metal oxide junctions.

**Highly Corrosion Resistant**

Even under continuous exposure to harsh environments White Bronze retains its aesthetic appearance. Unlike silver it does not discolor when exposed to sulphur, potassium sul-

phides etc., neither is there any build up in oxide layers as is the case with nickel. Furthermore, White Bronze parts have successfully passed all international salt spray tests (MIL, BS, CECC, IEC).

In conditions of continuously high temperatures (>100°C) and/or excessive humidity (>100%) there is no build up of foreign layers which may affect contact resistance.

**Low Porosity and No Reaction with Contact Surfaces**

Less than 2µm of White Bronze is needed to create a completely nonporous, corrosion resistant surface. Tyco Electronics applies White Bronze to a thickness of between 2µm and 3µm. This compares favorably with the typical plating thickness of nickel (>10µm) and consequently, variations in plating depth are significantly less.

White Bronze does not alloy with brass and since its coefficient of expansion is virtually identical to that of brass, rapid temperature shocks (-50°C/200°C) do not cause blistering or cracking of the plating.

The electrolytic potential of White Bronze is approximately that of brass. Consequently, any White

Bronze plated connectors in contact with stainless steel, silver, nickel or nickel containing finishes carry no risk of corrosion as a result of any chemical potential difference.

**Low RF Losses**

The relative permeability (µr) of the Tyco Electronics White Bronze is 1 giving rise to low RF losses even at high frequencies. As a direct result of the good conductivity of the finish, skin depth is minimized further reducing insertion loss and ensuring a better impedance match across the frequency range of the connectors.

**Non Magnetic Finish**

The Tyco Electronics White Bronze contains no ferrous materials and so has no magnetic properties. This is particularly desirable in many RF applications.

**Wear and Scratch Resistant**

The hardness of the Tyco Electronics White Bronze at 300-380HV is more than double that of silver and marginally harder than platings containing nickel. This gives a scratch resistance which is rarely surpassed and makes it ideal for high mating applications.

## Appendix B - White Bronze (Continued)



White Bronze is available on all products, including 7-16, N, TNC, OSP and SMA.

### Low Coefficient of Friction

The coefficient of friction is approximately 70% that of silver to give lower insertion forces and smoother coupling. These properties combine to produce a harder wearing, longer lasting finish which prolongs connector life and reduces the ongoing cost of ownership.

### Tyco Electronics' White Bronze

#### Environmental Test

Four groups of conditioning tests were performed to provide a comprehensive evaluation of the Tyco Electronics White Bronze plated connector bodies. The tests were performed to the specifications of the European and International RF connector standards - CECC 22000/ IEC 68-2-14/IEC 169-1. Full details and relevant data are available from Tyco Electronics and results are summarized below.

#### Test 1 - Industrial Atmosphere & Temperature

##### Endurance

*1.1 Industrial Atmosphere*  
Exposure to Sulphur Dioxide Atmosphere (as specified in IEC 68-2-42 Test Kc) for 21 days of mated connectors, previously subjected to 500 matings, to determine the influence of sulphur dioxide on the corrosion resistance properties of White Bronze

Plating. Contact resistance measured after matings and sulphur dioxide exposure was less than 5% (0.23mohm) of the permissible specification.

*1.2 High Temperature Endurance*  
Exposure to temperatures of 85°C ±5°C for 250 hours, to determine the impact of prolonged high temperatures on plating adhesion. Prior to testing the connectors were subject to 500 matings. Results showed no visual deterioration in plating finish (blistering, cracking etc.) and the results of outer conductivity performance were comparable to Test 1 (above).

#### Test 2 - Rapid Temperature Change & Damp Heat

##### Steady State

*2.1 Rapid Temperature Change*  
Exposure to -55°C and +85°C for 15 minutes, transition time 2-3 minutes, 50 cycles. To determine possible plating deterioration caused by prolonged and rapid temperature change. No visual deterioration, outer conductivity performance were comparable with Test 1 (above).

*2.2 Damp Heat Steady State*  
Exposure to 93% relative humidity (at 40°C) for 10 days. To determine plating adhesion. No visual deterioration, outer conductivity performance were comparable with Test 1 (above).

#### Test 3 - Soldering Heat

3.1 Resistance to Soldering Heat. Exposure to concentrated soldering heat (250°C) for 10 seconds to evaluate any possible deterioration in plating finish. No deterioration detected.

#### Test 4 - Salt Mist & Mechanical Endurance

##### 4.1 Salt Mist

Exposure to salt mist spray (as defined in BS 2011 Pt. 2.1 Ka) for 48 hours to evaluate the uniformity of protective coatings, any visual deterioration, or impact on electrical performance. No visual deterioration, outer conductivity performance were comparable with Test 1 (above).

*4.2 Mechanical Endurance*  
Electrical and visual evaluation of the connectors after 500 matings to determine any electrical or visual deterioration. No visual deterioration, outer conductivity performance were comparable with Test 1 (above).

#### Availability and Ordering

Tyco Electronics offers White Bronze on all products including 7-16, N, TNC, SMA and OSP. For more information on White Bronze contact your local Tyco Electronics Sales Office.

## Appendix C - Intermodulation in RF Coaxial Connectors

### Product Facts

- High quality plating to 6µm for IM-sensitive products
- Restrict materials to copper and its alloys
- Avoid the use of stainless steel, nickel, ferrites, etc. in the signal path
- Quality machining
- Ensure, by design, a properly defined contact interface at connector, panel and contact interfaces
- Avoidance of crimps

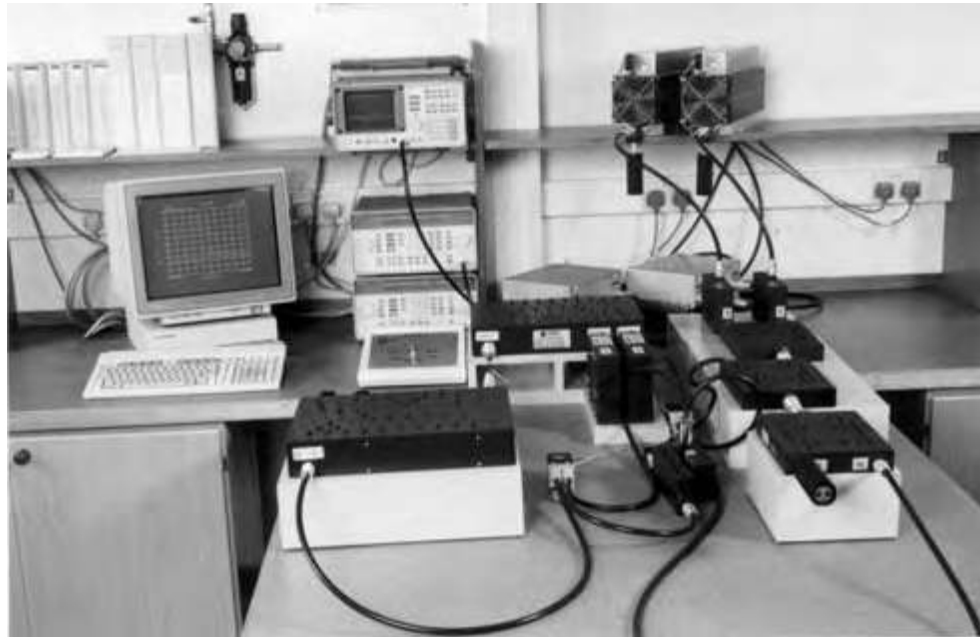

The increased demand from the mobile communication industry to provide greater channel capacity coupled with the increased sensitivity of receivers has exposed a condition within RF Coaxial Connectors referred to as Intermodulation Distortion (IMD). This condition occurs when non-linearities within the connectors act as imperfect diodes to generate other frequencies known as Intermodulation Products (IMP). Some of these frequencies appear within the receive band and effectively block the channel. The purpose of this application note is to outline the basic causes of Intermodulation and the techniques Tyco Electronics has undertaken to minimize this condition.

### IM Basics

Modern developments in base stations for GSM, DCS 1800 and PCS 1900 have necessitated the use of "7-16", "4.1/9.5" and "N" connectors due to the increased power requirements. The requirements for performance are typically in the order of -

160 dBc to -163dBc (when working in dBc) or -120dBm (when working in dBm), both with 2 x (+43dBm) tones. The requirement is so stringent because the connectors are used in post-filtering sections of the transmit path (between the diplexer and the antenna) and also because the system is a full duplex system where the multiple-carrier transmit path is also the receive path. In a truly linear system, the output is directly proportional to the input, following the form of  $y=mx+c$  (see fig. 2). Coaxial connectors have traditionally been viewed as following this pattern. In reality, there have always been non-linearities present in coaxial connectors. These were not readily apparent as the resultant IM products were significantly below the noise floor of the system due to relatively weak carrier signals. This situation becomes apparent when the incident power is raised above 30 dBm.

The small non-linearities have a characteristic similar to a square-law (see Fig 3). The distortion to the waveform is evident, the

### Need more information?

Call Technical Support at the numbers listed below. Technical Support is staffed with specialists well versed in all Tyco Electronics products. They can provide you with:

- Technical Support
- Catalogs
- Technical Documents
- Product Samples
- Tyco Electronics Authorized Distributor Locations

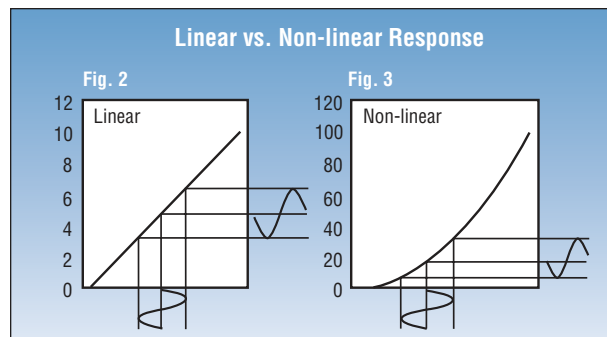



**Appendix C - Intermodulation in RF Coaxial Connectors (Continued)**

**IM Basics (Continued)**

positive 1/2 cycle being significantly greater in amplitude than the negative 1/2-cycle. When converted to the frequency domain, this waveform consists of the desired fundamental plus a decaying series of related harmonics that, in themselves, interact with other carriers present on the transmission line.

The effect of this interaction produces additional frequencies, some of which occur where they are least wanted (see fig. 4). The 2F1-F2 (3rd order IMP), 3F1-2F2 (5th order IMP) and 4F1-3F2 (7th order IMP) products can all manifest in the receive band and, if sufficiently large, effectively block a channel by making the base station receiver think that a carrier is present when one is not.

**Potential causes of IM in Coaxial Connectors**

There are numerous factors which can affect intermodulation performance in RF coaxial connectors. Identified below are the most likely sources of concern:

- Contaminated plating solution
- Insufficient plating thickness
- Corrosion
- Dissimilar metals in intimate contact

**Remedies for IM in RF Coaxial Connectors**

To combat the above identified IM sources, Tyco Electronics undertakes precautions during the design and manufacture of the product, as summarized below:

- High quality plating to 6µm for IM-sensitive products

The plating must also be free from contaminants and properly passivated with a chromate passivate. Silver has been the preferred plating material as it possesses the lowest practical resistivity thereby minimizing interface contact resistances. Tyco Electronics also offers a unique White Bronze plating finish which provides excellent durability, tarnish resistance and non-magnetic properties ideal for low intermodulation. During testing with a system noise floor of -145 dBm, the difference in performance between the Tyco Electronics silver-plating and the Tyco Electronics White Bronze finish is not discernible (refer to White Bronze Application Note 1307057).

- Restrict materials to copper and its alloys.

This ensures maximum plating adhesion and minimum electrochemical potential difference between the base materials and their over-platings.

- Avoid the use of stainless steel, nickel, ferrites, etc. in the signal path

Magnetic and para-magnetic materials will only compound non-linearities and give poorer interface contact resistances. During experimentation, Tyco Electronics discovered a degradation in performance of 20dB when nickel plate was used. The presence of magnetic or para-magnetic materials will also cause the forward IMP figure to differ from the reverse IMP.

- Quality machining

Surface finish is paramount. The signal propagates within a "skin" if this skin is too rough, the signal will repeatedly transition through metal and surface oxide layers, thereby creating the

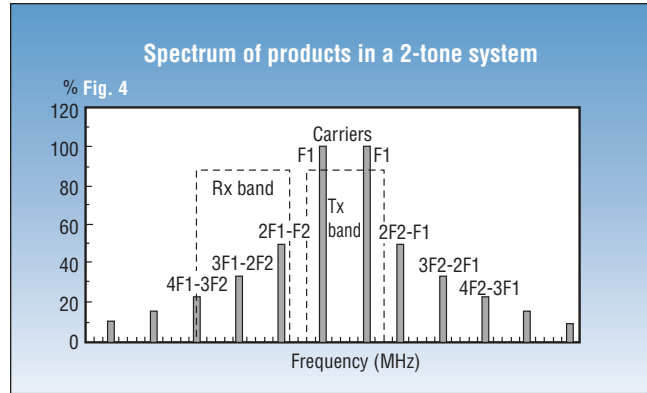

- Magnetic materials in the signal path
- Low contact pressure
- Less than 360-degree contact
- Poor surface finish
- Debris and dust within the connector
- Convoluted signal path

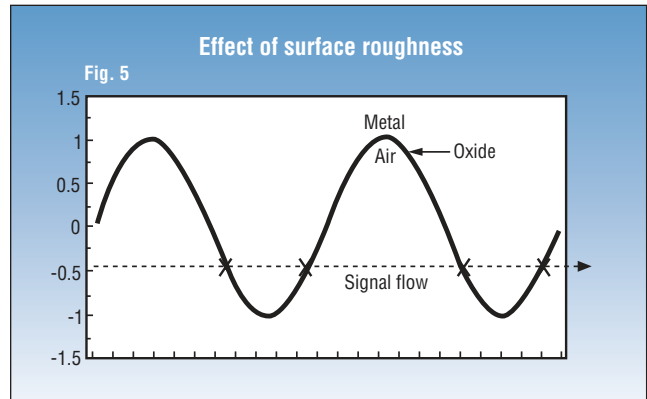

same effect as a poor panel contact (see fig. 5). For IM-sensitive designs Tyco Electronics ensures 0.4µm is the maximum.

- Contact design

This primarily affects the connector interface. Repeated matings can generate small amounts of plating from the individual parts. These oxidize and interfere with the mechanical (and therefore electrical) mating of connectors. The oxidized debris gives further rise to metal and surface oxide junctions and consequently, higher IM products.

- Ensure, by design, a properly defined contact interface at connector, panel and contact interfaces

Insufficient contact force will give rise to metal to oxide junctions. The classic rectifiers were metal oxide by composition.

Axial maximum material condition at the connector interface is critical in order to ensure minimum mismatch and maximum

## Appendix C - Intermodulation in RF Coaxial Connectors (Continued)

### Remedies for IM in RF Coaxial Connectors (Continued)

potential of a butt-contact. Panel interfaces generally concern the physical contact of the connector body to the panel. In this case, it has been determined that a protruding feature as close as possible to the body bore will give the best IM performance. The applied mounting force is concentrated in the surface area of the protrusion which, on engagement with the panel, punctures the existing oxide layer to give a metal-to-metal, gas-tight junction.

### Improving IM Connector Design

Tyco Electronics continues to pursue design techniques which improve intermodulation performance to address emerging telecommunication market needs. A state of the art intermodulation test facility and participation on the international (IEC SC46D WG5) committee to develop standard test practices

#### ■ Avoidance of crimps

Crimps, by nature, can only give multiple point-contact rather than 360-degree contact and also cause a variability in the position of electrical contact during dynamic testing. IM products will therefore be greater. It has been found that soldered center contacts and clamp/solder outer contacts give the best static and dynamic IM performance.

### Most commonly asked questions regarding Intermodulation

#### 1. Why is intermodulation such a concern for cellular infrastructure equipment?

The primary concerns for cellular service providers today are channel efficiency and clarity of transmission. Growth in demand for mobile communications has created a need to operate equipment at greater capacities and reliability to service the competitive market. Intermodulation degrades or limits the ability of the service provider to operate at optimal levels of performance and may ultimately cause subscribers to experience poor call quality. Intermodulation has become an important factor in system selection to ensure the best possible network service.

#### 2. Where is intermodulation most likely to occur in cellular infrastructure equipment?

Intermodulation is typically of greatest concern between the filtering elements of the system and the antenna. The introduction of higher power levels for the transmit side of the equipment creates greater potential for intermodulation to occur. This is why the majority of focus for intermodulation concerns 7-16, Type N, SMA and 4.1/9.5 connector interfaces.

#### 3. Is intermodulation a recent development?

Intermodulation has always been inherently present in RF coaxial connectors but may be relatively imperceptible in some devices for a variety of reasons. The amount of power applied to an RF connector determines the relative IM threshold which can be observed. Intermodulation is therefore more likely to cause concern in a higher power system, for example, utilizing a 7-16 connector interface rather than an equivalent low power OSX solution. The trend toward higher power digital cellular systems creates the need for greater intermodulation sensitivity.

#### 4. What is the best method of cable attachment for IM sensitive cable assembly applications?

Soldering and clamping are preferred methods due to the 360-degree point of contact created at the cable to connector interface. Such intimate contact improves the overall contact resistance leading to improved IM characteristics. In addition, it is also better to solder the center conductor of the connector to the cable versus crimping due to the improved contact resistance path and elimination of voids.

ensures our commitment to the understanding of intermodulation characteristics. This applied technology base is instrumental in developing innovative low intermodulation products for 7-16, Type N, SMA and OSP interfaces.

#### 5. Are there ways to test for intermodulation in an RF coaxial connector?

Yes, very sophisticated methods are needed to test for intermodulation in RF connectors. The test system must utilize extremely sensitive filtering or clean amplification so that the equipment itself has a very low intermodulation noise floor. There is not yet a standardized approach to testing, although an international committee has been formed in the connector industry to address the situation. Tyco Electronics has a state of the art test facility where our designs are optimized for low intermod performance and where further analysis on the effects of this phenomena can be studied.

#### 6. Is intermodulation in coaxial connectors frequency dependent?

No. Because coaxial connectors are broadband devices there is no frequency dependency. Some apparent variability can be detected during testing but this is not due to the connector. The impedance matches of the output diplexer/triplexer and terminations are the causes of the variations and should not be incorrectly attributed to the connector/assembly. Tyco Electronics Interconnect Business Unit has demonstrated that by varying the impedance match of the test station termination, a DUT can show 15dB better  $IMP_3$  than exists in reality.

#### 7. $IMP_3$ in mixers follows a 3dB/dB relationship. What is it for connectors?

The relationship is identical. Taking the 3rd order (2F1-F2): varying the power of F2 gives an  $IMP_3$  relationship of 1dB/dB whereas varying the power of F1 gives a relationship of 2dB/dB as the  $IMP$  is derived from the 2nd harmonic of F1. This gives a total of 3dB/dB when symmetrically varying both carrier powers.

#### 8. I am buying a complete cable assembly from Tyco Electronics. How do I interpret the $IMP$ result now?

With caution! It is the Tyco Electronics policy when testing devices to move away from the normal static test to a dynamic test where the cable termination interfaces are mechanically exercised during live IM conditions. It is also a good indicator to customers of the build quality of the assemblies. A dynamic evaluation has shown 15dB degradation in  $IMP$  performance for poor assemblies and even as much as 50dB for bad ones. It is therefore strongly advisable that  $IMP$  performance figures are stated in the context of a dynamic measurement.

## Appendix D - Typical Coaxial Cable Specifications

### Abbreviations

#### Dielectric

PE .....Solid polyethylene  
 PTEE .....Solid polytetrafluoroethylene  
 PIB .....Polyisobutylene, Type B, per MIL-C-17  
 Rubber .....Per MIL-C-17D  
 Sil .....Silicone rubber  
 PS .....Polystyrene

#### Conductors and Braid Materials

AL .....Aluminum  
 SCAAL .....Silver covered copper covered aluminum  
 BC .....Bare copper  
 SC .....Silver covered copper  
 CCS .....Copper covered steel  
 TC .....Tinned copper  
 SCCS .....Silver covered copper covered steel

SCCad Br .....Silver covered cadmium bronze  
 GS .....Galvanized steel  
 TCCS .....Tin copper covered steel  
 SSC .....Silver covered strip  
 HR .....High resistance wire  
 SA .....Silver covered alloy

#### Jacket Material

PVC-I .....Black polyvinylchloride, contaminating, Type I, per MIL-C-17D  
 PVC-II .....Gray polyvinylchloride, noncontaminating, Type II, per MIL-C-17D  
 PVC-IIA .....Black polyvinylchloride, noncontaminating, Type IIA, per MIL-C-17D  
 PE-III .....Clear polyethylene  
 PE-IIIA .....High molecular weight, black polyethylene, Type IIIA, per MIL-C-17D  
 FG Braid V .....Fiberglass, impregnated, Type V, per MIL-C-17D  
 FEP-IX .....Fluorinated ethylene propylene, Type IX, per MIL-C-17D  
 PUR .....Polyurathane, black specific compounds  
 SIL/DAC-VI .....Dacron braid over silicone rubber, Type VI, per MIL-C-17D  
 Rubber .....Per MIL-C-17D

RG/U Type Cable	Inner Conductor	Dielectric Material	DOD	Number/Type of Shielding Braids	Jacket Material	O.D.	Weight (lb/ft)	Nom. Imped. (Ohms)	Nom. Cap pf/ft	Max. Operating Temp. (C°)	Max. Operating Voltage (Volts RMS)	Comments
4	0.81 BC .0320	PE	.295 .116	2/BC	PVC-1	5.74 .226	.025	50	30.8	-40 +80	1900	Use RG 58C
5	1.29 BC .0508	PE	4.7 .185	2/BC	PVC-1	8.43 .332	.088	52.5	28.5	-40 +80	3000	Use up to 100 MHz
5A	1.29 SC .0508	PE	4.6 .181	2/SC	PVC-II	8.33 .328	.088	50	30.8	-40 +80	3000	Use RG 212
5B	1.29 SC .0508	PE	4.6 .181	2/SC	PVC-IIA	8.33 .328	.087	50	30.8	-40 +80	3000	Use RG 212
6	0.72 CCS .0285	PE	4.7 .185	2/Inner SC Outer BC	PVC-II	8.43 .332	.081	76	20.0	-40 +80	2700	Use RG 6A
6A	0.72 CCS .0285	PE	4.7 .185	2/Inner SC Outer BC	PVC-IIA	8.43 .332	.082	75	20.6	-40 +80	2700	Good Attenuation Stability
7	0.91 BC .0359	Air-Space PE	6.35 .250	1/BC	PVC-I	9.4 .370	.080	95	12.5	-40 +80	1000	Use RG 63B
8	2.17 .0855 7/0.72 BC .0285	PE	7.24 .285	1/BC	PVC-I	10.29 .405	.106	52	29.5	-40 +80	4000	Use RG 213
8A	2.17 .0855 7/0.72 BC .0285	PE	7.24 .285	1/BC	PVC-IIA	10.29 .405	.106	52	29.5	-40 +80	5000	Use RG 213
9	2.17 .0855 7/0.72 SC .0285	PE	7.11 .280	2/Inner SC Outer BC	PVC-II	10.67 .420	.140	51	30.0	-40 +80	4000	Use RG 214
9A	2.17 .0855 7/0.72 SC .0285	PE	7.11 .280	2/SC	PVC-II	10.67 .420	.140	51	30.0	-40 +80	4000	Use RG 214
9B	2.17 .0855 7/0.72 SC .0285	PE	7.11 .280	2/SC	PVC-IIA	10.67 .420	.150	50	30.8	-40 +80	5000	Use RG 214
10	2.17 .0855 7/0.72 BC .0285	PE	7.24 .285	1/BC	PVC-II w/Armor	11.76 .463	.146	52	29.5	-40 +80	4000	Use RG 215
10A	2.17 .0855 7/0.72 BC .0285	PE	7.24 .285	1/BC	PBC-IIA w/Armor	11.76 .463	.146	52	29.5	-40 +80	5000	Use RG 215
11	1.21 .0477 7/0.4 TC .0159	PE	7.24 .285	1/BC	PVC-I	10.29 .405	.096	75	20.6	-40 +80	4000	Use up to 100 MHz
11A	1.21 .0477 7/0.4 TC .0159	PE	7.24 .285	1/BC	PVC-IIA	10.29 .405	.096	75	20.6	-40 +80	5000	Use up to 1000 Mhz
12	1.21 .0477 7/0.4 TC .0159	PE	7.24 .285	1/BC	PVC-II w/Armor	11.76 .463	.141	75	20.6	-40 +80	4000	Use RG 12A

**Appendix D - Typical Coaxial Cable Specifications** (Continued)

RG/U Type Cable	Inner Conductor	Dielectric Material	DOD	Number/Type of Shielding Braids	Jacket Material	O.D.	Weight (lb/ft)	Nom. Imped. (Ohms)	Nom. Cap pf/ft	Max. Operating Temp. (C°)	Max. Operating Voltage (Volts RMS)	Comments
12A	1.21 .0477 7/0.4 TC .0159	PE	7.24 .285	1/BC	PVC-IIA w/Armor	11.76 .463	.141	75	20.6	-40 +80	5000	Use up to 1000 MHz
13	1.21 .0477 7/0.4 TC .0159	PE	7.11 .280	2/BC	PVC-I	10.67 .420	.126	74	20.8	-40 +80	4000	Use RG 216
13A	1.21 .0477 7/0.4 TC .0159	PE	7.11 .280	2/BC	PVC-IIA	10.67 .420	.126	52	20.8	-40 +80	4000	Use RG 216
14	2.59 BC .1020	PE	9.4 .370	2/BC	PVC-II	13.84 .545	.216	52	29.5	-40 +80	5500	Use RG 217
14A	2.59 BC .1020	PE	9.4 .370	2/BC	PVC-IIA	13.84 .545	.216	76	29.5	-40 +80	7000	Use RG 217
15	1.45 CCS .0571	PE	9.4 .370	2/BC	PVC-I	13.84 .545	.197	52	20.0	-40 +80	5000	Use up to 1000 MHz
16	2.59 BC .1250 Tube	PE	11.68 .460	1/BC	PVC-I	16 .630	.254	52	29.5	-40 +80	6000	Use up to 1000 MHz
17	4.78 BC .1880	PE	17.27 .680	1/BC	PVC-II	22.1 .870	.460	52	29.5	-40 +80	11,000	Use up to 1000 MHz
17A	4.78 BC .1880	PE	17.27 .680	1/BC	PVC-IIA	22.1 .870	.460	52	29.5	-40 +80	11,000	Use RG 218
17B	Cancelled, Reassigned New Nomenclature, RG 177											
18	4.78 BC .1880	PE	17.27 .680	1/BC	PVC-II w/Armor	23.50 .925	.585	52	29.5	-40 +80	11,000	Use RG 219
18A	4.78 BC .1880	PE	17.27 .680	1/BC	PVC-IIA w/Armor	23.57 .928	.585	52	29.5	-40 +80	11,000	Use RG 219
19	6.35 BC .2500	PE	23.11 .910	1/BC	PVC-II	28.45 1.120	.740	52	29.5	-40 +80	14,000	Use RG 220
19A	6.35 BC .2500	PE	23.11 .910	1/BC	PVC-IIA	28.45 1.120	.740	52	29.5	-40 +80	14,000	Use RG 220
20	6.35 BC .2500	PE	23.11 .910	1/BC	PVC-II w/Armor	29.92 1.178	.925	52	29.5	-40 +80	14,000	Use RG 221
20A	6.35 BC .2500	PE	23.11 .910	1/BC	PVC-IIA w/Armor	29.92 1.178	.925	53	29.5	-40 +80	14,000	Use RG 221
21	1.29 0508 High Res. Wire	PE	4.7 .185	2/SC	PVC-II	8.43 .332	.087	53	29.0	-40 +80	2700	Use RG 222
21A	1.29 0508 High Res. Wire	PE	4.7 .185	2/SC	PVC-IIA	8.43 .332	.087	95	29.0	-40 +80	2700	Use RG 222
22	2 Cond. 1.16 .0456 7/0.39 BC .0152	PE	7.24 .285	1/TC	PVC-I	10.29 .405	.105	95	16.0	-40 +80	1000	Balanced Line w/Twisted Cond.
22A	2 Cond. 1.16 .0456 7/0.39 BC .0152	PE	7.24 .285	2/TC	PVC-II	10.67 .420	.151	95	16.0	-40 +80	1000	Balanced Line w/Twisted Cond.
22B	2 Cond. 1.16 .0456 7/0.39 BC .0152	PE	7.24 .285	2/TC	PVC-IIA	10.67 .420	.151	125	16.0	-40 +80	1000	Balanced Line w/Twisted Cond.
23	2 Cond. 2.17 .0855 7/0.72 BC .0285	PE, 2 Cores	9.65 .380	2/Individual Inner Common Outer BC	PVC-I	16.51 x .490 .650 24 .945	.490	125	12.0	-40 +80	3000	Use RG 23A
23A	2 Cond. 2.17 .0855 7/0.72 BC .0285	PE, 2 Cores	9.65 .380	2/Individual Inner Common Outer BC	PVC-IIA	16.51 x .490 .650 24 .945	.490	125	12.0	-40 +80	3000	Dual Coaxial Balanced Line
24	2 Cond. 2.17 .0855 7/0.72 BC .0285	PE, 2 Cores	9.65 .380	2/Individual Inner Common Outer BC	PVC-I w/Armor	25.48 1.003 19.81 .780	.670	670	12.0	2/Individual -40 +80	3000	Use RG 24A

**Appendix D - Typical Coaxial Cable Specifications (Continued)**

RG/U Type Cable	Inner Conductor	Dielectric Material	DOD	Number/Type of Shielding Braids	Jacket Material	O.D.	Weight (lb/ft)	Nom. Imped. (Ohms)	Nom. Cap pf/ft	Max. Operating Temp. (C°)	Max. Operating Voltage (Volts RMS)	Comments
24A	2 Cond. <b>2.17</b> .0855 7/ <b>0.72</b> BC .0285	PE,2 Cores	<b>9.65</b> .380	2/Individual Inner Common Outer BC	PVC-IIA w/Armor	<b>25.48</b> 1.003 <b>19.81</b> .780	.670	125	12.0	-40 +80	3000	Use RG 23A
25A	<b>1.49</b> .0585 19/ <b>0.3</b> TC .0117	Rubber-E	<b>7.32</b> .288	2/TC	Rubber-IV	<b>12.83</b> .505	.205	48	50.0	-40 +80	10,000	—
26A	<b>1.49</b> .0585 19/ <b>0.3</b> TC .0117	Rubber-E	<b>7.32</b> .288	1/TC	Rubber-IV w/Armor	<b>12.27</b> .483	.189	48	50.0	-40 +80	10,000	—
27A	<b>2.35</b> .0925 19/ <b>0.47</b> TC .0185	Rubber-D	<b>11.56</b> .455	1/TC	Rubber-IV w/Armor	<b>16.59</b> .653	.304	48	50.0	-40 +80	15,000	—
28B	<b>2.35</b> .0925 19/ <b>0.47</b> TC .0185	Rubber-D	<b>11.56</b> .455	2/TC, GS	Rubber-IV w/Armor	<b>19.05</b> .750	.370	48	50.0	-40 +80	15,000	—
29	<b>0.81</b> BC .0320 <b>1.21</b> .0477	PE	<b>2.95</b> .116	1/TC	PE-111	<b>4.67</b> .184	0.21	53.5	28.5	-55 +80	1900	Use RG 58
30	7/ <b>0.4</b> BC .0159	PIB	<b>4.7</b> .185	1/BC	PVC-I	<b>6.35</b> .250	.044	50	27.0	-40 +80	1500	Use RG 58
31	<b>2.17</b> .0855 7/ <b>0.72</b> BC .0285	PIB	<b>7.24</b> .285	1/BC	PVC-I	<b>10.29</b> .405	.106	51	31.0	-40 +80	2000	Use RG 213
32	<b>2.17</b> .0855 7/ <b>0.72</b> BC .0285	PIB	<b>7.24</b> .285	1/BC	PVC-I w/Armor	<b>11.81</b> .465	.141	51	29.0	-40 +80	2000	Use RG 215
33	<b>2.59</b> BC .1019	PE	<b>9.4</b> 3.70	None	Lead	<b>11.94</b> .470	.390	51	30.0	-55 +80	6000	—
34	<b>2.17</b> .0855 7/ <b>0.72</b> BC .0285	PE	<b>11.56</b> .455	1/BC	PVC-I	<b>15.88</b> .625	.224	71	21.5	-40 +80	5200	Use RG 31B
34A	<b>1.9</b> .0747 7/ <b>0.63</b> BC .0249	PE	<b>11.68</b> .460	1/BC	PVC-IIA	<b>16</b> .630	.224	75	20.6	-40 +80	6500	Use RG 34B
34B	<b>1.9</b> .0747 7/ <b>0.63</b> BC .0249	PE	<b>11.68</b> .460	1/BC	PVC-IIA	<b>16</b> .630	.224	75	20.6	-40 +80	6500	Use up to 1000 MHz
35	<b>2.91</b> BC .1144 <b>1.6</b> 0.63	PE	<b>11.68</b> .460	1/BC	PVC-II w/Armor	<b>23.57</b> .928	.525	71	21.5	-40 +80	10,000	Use RG 35B
35A	<b>2.65</b> BC .1045	PE	<b>11.68</b> .460	1/BC	PVC-IIA w/Armor	<b>23.57</b> .928	.525	75	20.6	-40 +80	10,000	Use RG 35B
35B	<b>2.65</b> BC .1045	PE	<b>11.68</b> .460	1/BC	PVC-IIA	<b>23.57</b> .928	.525	75	20.6	-40 +80	10,000	Unarmored: see RG 164
36	<b>4.11</b> BC .1620	PE	<b>23.11</b> .910	1/BC	PVC-I	<b>29.97</b> 1.180	.805	69	22.0	-40 +80	13,000	Use up to 1000 MHz
37	<b>0.81</b> TC .0320	Rubber-C	<b>3.56</b> .140	1/TC	PE-III	<b>5.33</b> .210	.040	52.5	38.0	-55 +80	750	—
38	<b>1.15</b> TC .0453	Rubber-C	<b>4.98</b> .196	2/TC	PE-III	<b>7.92</b> .312	.110	52.5	38.0	-55 +80	1000	—
39	<b>0.64</b> CCS .0253	Rubber-C	<b>4.98</b> .196	2/TC	PE-III	<b>7.92</b> .312	.100	72.5	28.6	-55 +80	1000	—
40	<b>0.64</b> CCS .0253	Rubber-C	<b>4.98</b> .196	2/TC	Rubber IV	<b>10.67</b> .420	.150	72.5	28.0	-40 +80	1000	—
41	<b>1.24</b> .0490 16/ <b>0.25</b> TC .0100	Rubber-IV	<b>6.35</b> .250	1/TC	Rubber-IV	<b>10.8</b> .425	.150	67.5	27.6	-40 +80	3000	—
42	<b>0.72</b> .0285 Res. Wire	PE	<b>4.98</b> .196	2/SC	PVC-II	<b>8.69</b> .342	.050	78	20.0	-40 +80	2700	Use RG 222

**Appendix D - Typical Coaxial Cable Specifications (Continued)**

RG/U Type Cable	Inner Conductor	Dielectric Material	DOD	Number/Type of Shielding Braids	Jacket Material	O.D.	Weight (lb/ft)	Nom. Imped. (Ohms)	Nom. Cap pf/ft	Max. Operating Temp. (C°)	Max. Operating Voltage (Volts RMS)	Comments
43	2 Cond. <b>2.17</b> 0855 7/ <b>0.72</b> BC 0285	Rubber-B	<b>11.99</b> .427	1/BC	PVC-I	<b>15.67</b> .617	—	95	17.6	-40 +80	1500	Use RG 57
54	<b>1.21</b> 0477 7/ <b>0.4</b> BC 0159	PE	<b>4.7</b> .185	1/BC	PVC-I	<b>6.99</b> .275	.045	58	27.0	-40 +80	2500	Use RG 54A
54A	<b>1.16</b> 0456 7/ <b>0.39</b> BC 0152	PE	<b>4.52</b> .178	1/TC	PE-III	<b>6.22</b> 2.45	.041	58	26.5	-55 +80	3000	Use up to 1000 MHz
55	<b>0.81</b> BC 0320	PE	<b>2.95</b> .116	2/TC	PE-III	<b>5.08</b> .200	.032	53.5	28.5	-55 +80	1900	Use RG 55B
55A	<b>0.89</b> SC 0350	PE	<b>2.95</b> .116	2/SC	PVC-IIA	<b>5.08</b> .200	.034	50	30.8	-40 +80	1900	Use RG 223
55B	<b>0.81</b> SC 0320	PE	<b>2.95</b> .116	2/TC	PE-IIIA	<b>5.08</b> .200	.033	53.5	28.5	-55 +80	1900	Use up to 1000 MHz
56	<b>1.49</b> 0585 19/ <b>0.3</b> BC 0117	Rubber-D	<b>7.82</b> .308	2/BC	PVC-I	<b>13.59</b> .535	.243	48	50.0	-40 +80	8000	—
57	2 Cond. <b>2.17</b> 0855 7/ <b>0.72</b> BC 0285	PE	<b>11.99</b> .472	1/TC	PVC-I	<b>15.88</b> .625	.225	95	17.0	-40 +80	3000	Balanced Line Parallel
57A	2 Cond. <b>2.17</b> 0855 7/ <b>0.72</b> BC 0285	PE	<b>11.99</b> .472	1/TC	PVC-IIA	<b>15.88</b> .625	.225	95	17.0	-40 +80	3000	Balanced Line Parallel
58	<b>0.81</b> BC 0320	PE	<b>2.95</b> .116	1/TC	PVC-I	<b>4.95</b> .195	.029	53.5	28.5	-40 +80	1900	Use RG 58B
58A	<b>0.9</b> 0355	PE	<b>2.95</b> .116	1/TC	PVC-I	<b>4.95</b> .195	.029	52	28.5	-40 +80	1900	Use RG 58C
58B	<b>0.81</b> BC 0320	PE	<b>2.95</b> .116	1/TC	PVC-IIA	<b>4.95</b> .195	.029	53.5	28.5	-40 +80	1900	Use up to 1000 MHz
58C	<b>0.9</b> 0355 19/ <b>0.8</b> TC 0071	PE	<b>2.95</b> .116	1/TC	PVC-IIA	<b>4.95</b> .195	.029	50	30.8	-40 +80	1900	Extra Flexible Version RG 58B
59	<b>0.64</b> CCS 0253	PE	<b>3.71</b> .146	1/BC	PVC-I	<b>6.15</b> .242	.032	73	21.0	-40 +80	2300	Use RG 59B
59A	<b>0.64</b> CCS 0253	PE	<b>3.71</b> .146	1/BC	PVC-IIA	<b>6.15</b> .242	.032	73	21.0	-40 +80	2300	Use RG 59B
59B	<b>0.58</b> CCS 0230	PE	<b>3.71</b> .146	1/BC	PVC-IIA	<b>6.15</b> .242	.032	75	20.6	-40 +80	2300	Use up to 1000 MHz
60	<b>1.29</b> Str. C 0508	Rubber-C	<b>6.35</b> .250	1/BC	Rubber-IV	<b>10.8</b> .425	.150	50	39.0	-40 +80	1100	—
62	<b>0.64</b> CCS 0253	Air-space PE	<b>3.71</b> .146	1/BC	PVC-I	<b>6.15</b> .242	.038	93	13.5	-40 +80	750	Use RG 62A Low
62A	<b>0.64</b> CCS 0253	Air-space PE	<b>3.71</b> .146	1/BC	PVC-IIA	<b>6.15</b> .242	.038	93	13.5	-40 +80	750	Capacitance
62B	<b>0.61</b> 0240 7/ <b>0.2</b> CCS 0080	Air-space PE	<b>3.71</b> .146	1/BC	PVC-IIA	<b>6.15</b> .242	.038	93	13.5	-40 +80	750	Extra Flexible RG 62A
63	<b>0.64</b> CCS 0253	Air-space PE	<b>7.24</b> .285	1/BC	PVC-I	<b>10.29</b> .405	.083	125	10.0	-40 +80	1000	Use RG 63B
63A	<b>0.64</b> BC 0253	Air-space PE	<b>7.24</b> .285	1/BC	PVC-I	<b>10.29</b> .405	.083	125	10.0	-40 +80	1000	Use RG 63B
63B	<b>0.64</b> CCS 0253	Air-space PE	<b>7.24</b> .285	1/BC	PVC-IIA	<b>10.29</b> .405	.083	125	10.0	-40 +80	1000	Low Capacitance
64	<b>1.49</b> 0585 19/ <b>0.3</b> TC 0117	Rubber-D	<b>7.82</b> .308 <b>7.24</b> .285	2/TC	Rubber-IV	<b>12.57</b> .495 <b>10.29</b> .405	.225	48	60.0	-40 +80	10,000	— Capacitance
64A	<b>1.49</b> 0585 19/ <b>0.3</b> TC 0117	Rubber-E	<b>7.32</b> .288	2/TC	Rubber-IV	<b>11.68</b> .460	.205	48	50.0	-40 +80	10,000	—
65	<b>0.2</b> [.0080] Formex-F <b>3.25</b> [.1280] Dia. Helix	PE	<b>7.24</b> .285	1/BC	PVC-I	<b>10.29</b> .405	.096	950	44.0	-40 +80	1000	High Impedance Video Delay Line



**Appendix D - Typical Coaxial Cable Specifications (Continued)**

RG/U Type Cable	Inner Conductor	Dielectric Material	DOD	Number/Type of Shielding Braids	Jacket Material	O.D.	Weight (lb/ft)	Nom. Imped. (Ohms)	Nom. Cap pf/ft	Max. Operating Temp. (C°)	Max. Operating Voltage (Volts RMS)	Comments
65A	<b>.02</b> [.0080] Formex-F <b>3.25</b> [.1280] Dia. Helix	PE	<b>7.24</b> .285	1/BC	PVC-IIA	<b>10.29</b> .405	.096	950	44.0	-40 +80	1000	High Impedance Video Delay Line
71	<b>0.64</b> CCS .0253	Air-space PE	<b>3.71</b> .146	2/TC	PVC-I	<b>6.22</b> .245	.046	93	13.5	-40 +80	750	Use RG 71B
71A	<b>0.64</b> CCS .0253	Air-space PE	<b>3.71</b> .146	2/TC	PE-III	<b>6.22</b> .245	.046	93	13.5	-55 +80	750	Use RG 71B
71B	<b>0.64</b> CCS .0253	Air-space PE	<b>3.71</b> .146	2/TC	PE-IIIA	<b>6.22</b> .245	.046	93	13.5	-55 +80	750	Low Capacitance
72	<b>0.64</b> CCS .0253	Air-space PE	<b>11.68</b> .460	1/BC	PVC-I	<b>16</b> .630	.169	150	7.8	-40 +80	750	Low Capacitance
73	<b>1.65</b> BC .0650	PE	<b>2.95</b> .116	2/BC	Copper Braid	<b>4.45</b> .175	.031	25	61.8	-55 +80	1000	Low Impedance
74	<b>2.59</b> BC .1020	PE	<b>9.4</b> .370	2/BC	PVC-II w/Armor	<b>15.32</b> .603	.310	52	29.5	-40 +80	5500	Use RG 224
74A	<b>2.59</b> BC .1020	PE	<b>9.4</b> .370	2/BC	PVC-IIA w/Armor	<b>15.32</b> .603	.310	52	29.5	-40 +80	5500	Use RG 224
77A	<b>1.49</b> .0585 19/ <b>0.3</b> TC .0117	Rubber-E	<b>7.32</b> .288	2/TC	PVC-IIA	<b>11.43</b> .450	.195	48	50.0	-40 +80	8000 Peak	—
78A	<b>1.49</b> .0585 19/ <b>0.3</b> TC .0117	Rubber-E	<b>7.32</b> .288	1/TC	PVC-IIA	<b>10.67</b> .420	.149	48	50.0	-40 +80	8000 Peak	—
79	<b>0.64</b> CCS .0253	Air-space PE	<b>7.24</b> .285	1/BC	PVC-I w/Armor	<b>11.76</b> .463	.136	—	10.0	-40 +80	1000	Low Capacitance
79A	<b>0.64</b> CCS .0253	Air-space PE	<b>7.24</b> .285	1/BC	PVC-I w/Armor	<b>11.76</b> .463	.130	.125	10.0	-40 +80	1000	Low Capacitance
79B	<b>0.64</b> CCS .0253	Air-space PE	<b>7.24</b> .285	1/BC	PVC-IIA w/Armor	<b>11.76</b> .463	.136	.125	10.0	-40 +80	1000	Low Capacitance
81	<b>1.59</b> BC .0625	Magnesium Oxide G	<b>8.15</b> .321	None	Copper Tube	<b>8.26</b> .325	.172	50	37.0	250	3000	—
82	<b>3.18</b> BC .1250	Magnesium Oxide G	<b>16.51</b> .650	None	Copper Tube	<b>19.05</b> .750	.698	50	36.0	250	5000	—
83	<b>2.59</b> BC .1020	PE	<b>6.1</b> .240	1/BC	PVC-I	<b>10.29</b> .405	.120	35	44.0	-40 +80	2000	Low Impedance
84A	<b>2.65</b> BC .1045	PE	<b>17.27</b> .680	1/BC	PVC-IIA w/Lead Sheath	<b>25.4</b> 1.000	1.325	75	20.6	-40 +80	10,000	RG 35B with Special Armor
85A	<b>2.65</b> BC .1045	PE	<b>17.27</b> .680	1/BC	PVC-IIA w/Lead Armor	<b>39.75</b> 1.565	2.910	75	20.6	-40 +80	10,000	RG 84A with Special Armor
86	2 Cond. <b>2.17</b> .0855 7/ <b>0.72</b> BC .0285	PE	<b>7.62</b> .300 x <b>16.51</b> .650	None	None	<b>7.62</b> .300 x <b>16.51</b> .650	.100	200	7.8	-55 +80	10,000	Twin Lead
87A	<b>2.44</b> .0960 7/ <b>0.81</b> SC .0320	PTFE	<b>7.11</b> .280	2/SC	FG Braid-V	<b>10.8</b> .425	.180	50	29.4	-55 +250	5000	Use RG 225
88	<b>1.49</b> .0585 19/ <b>0.3</b> TC .0117	Rubber-E	<b>7.32</b> .288	4/TC	PVC-I	<b>13.08</b> .515	.211	48	50.0	-40 +80	10,000	—
88A	<b>1.49</b> .0585 19/ <b>0.3</b> TC .0117	Rubber-E	<b>7.32</b> .288	4/TC	PVC-IIA	<b>13.08</b> .515	.211	48	50.0	-40 +80	10,000	—
88B	<b>1.49</b> .0585 19/ <b>0.3</b> TC .0117	Rubber-E	<b>7.32</b> .288	4/TC	Rubber-IV	<b>14.35</b> .565	.238	48	50.0	-40 +80	10,000	—
89	<b>0.64</b> CCS .0253	Air-space PE	<b>7.24</b> .285	1/BC	PVC-I	<b>16.05</b> .632	.195	125	10.0	-40 +80	1000	Low Capacitance
90	<b>1.53</b> .0603 7/ <b>0.51</b> SC .0201	PE	<b>4.95</b> .195	3/SC, GS, SC	PVC-IIA	<b>10.8</b> .425	—	50	30.8	-40 +80	3000	Excellent Shielding
93	<b>5.08</b> .2000 19/ <b>1.02</b> BC .0400	Taped PTFE	<b>14.55</b> .573	1/BC	FG Braid-V	<b>18.03</b> .710	.475	50	29.4	-55 +250	10,000	Use RG 211A

**Appendix D - Typical Coaxial Cable Specifications (Continued)**

RG/U Type Cable	Inner Conductor	Dielectric Material	DOD	Number/Type of Shielding Braids	Jacket Material	O.D.	Weight (lb/ft)	Nom. Imped. (Ohms)	Nom. Cap pf/ft	Max. Operating Temp. (C°)	Max. Operating Voltage (Volts RMS)	Comments
94	<b>2.86</b> .1125 19/ <b>0.57</b> SC .0225	Taped PTFE	<b>7.42</b> .292	2/BC	FG Braid-V	<b>11.3</b> .445	.270	50	29.4	-55 +250	7000	Use RG 226
94A	<b>3.23</b> .1270 19/ <b>0.65</b> SC .0254	Taped PTFE	<b>9.4</b> .370	2/BC	FG Braid-V	<b>12.7</b> .500	.445	50	29.4	-55 +250	7000	Use RG 226
100	<b>1.87</b> .0735 19/ <b>0.37</b> BC .0147	PE	<b>3.71</b> .146	1/BC	PVC-I	<b>6.15</b> .242	.046	35	44.0	-40 +80	2000	Use up to 1000 MHz
101	<b>1.63</b> BC .0641	Rubber	—	1/TC	—	<b>14.94</b> .588	—	75	—	—	—	—
102	2 Cond. <b>2.05</b> BC .0808	Rubber	—	1/TC	—	<b>27.64</b> 1.088	—	140	—	—	—	—
108	2 Cond. <b>0.96</b> .0378 7/ <b>0.32</b> TC .0126	PE	<b>2.01</b> .079 Each	1/TC	PVC-II	<b>5.97</b> .235	.032	78	19.6	-40 +80	1000	Use RG 108A
108A	2 Cond. <b>0.96</b> .0378 7/ <b>0.32</b> TC .0126	PE	<b>2.01</b> .079 Each	1/TC	PVC-IIA	<b>5.97</b> .235	.032	78	19.6	-40 +80	1000	Balanced Line
111	2 Cond. <b>1.16</b> .0456 7/ <b>0.39</b> BC .0152	PE	<b>7.24</b> .285	2/TC	PVC-II w/Armor	<b>12.14</b> .478	.146	95	16.0	-40 +80	1000	Use RG 111A
111A	2 Cond. <b>1.16</b> .0456 7/ <b>0.39</b> BC .0152	PE	<b>7.24</b> .285	2/TC	PVC-IIA w/Armor	<b>12.14</b> .478	.146	95	16.0	-40 +80	1000	Use RG 22B w/Armor
114	<b>0.18</b> CCS .0070	Air-space PE	<b>7.24</b> .285	1/BC	PVC-I	<b>10.29</b> .405	.087	185	6.5	-40 +80	1000	Use RG 114A
114A	<b>0.18</b> CCS .0070	Air-space PE	<b>7.24</b> .285	1/BC	PVC-IIA	<b>10.29</b> .405	.087	185	6.5	-40 +80	1000	Low Capacitance
115	<b>2.13</b> .0840 7/ <b>0.71</b> SC .0280	Taped PTFE	<b>6.35</b> .250	2/BC	FG Braid-V	<b>9.53</b> .375	.148	50	29.4	-55 +250	5000	Use RG 115A
115A	<b>2.13</b> .0840 7/ <b>0.71</b> SC .0280	Taped PTFE	<b>6.48</b> .255	2/BC	FG Braid-V	<b>10.54</b> .415	.180	50	29.4	-55 +250	5000	Extra Flexible RG 225
116	<b>2.44</b> .0960 7/ <b>0.81</b> SC .0320	PTFE	<b>7.11</b> .280	2/SC	FG Braid-V w/Armor	<b>12.7</b> .475	.198	50	29.4	-55 +250	5000	Use RG 227
117	<b>4.78</b> BC .1880	PTFE	<b>15.75</b> .620	1/BC	FG Braid-V	<b>18.54</b> .730	.641	50	29.4	-55 +250	7000	Use RG 211A
117A	<b>4.78</b> BC .1880	PTFE	<b>15.75</b> .620	1/BC	FG Braid-V	<b>18.54</b> .730	.641	50	29.4	-55 +250	7000	Use RG 211A
118	<b>4.78</b> BC .1880	PTFE	<b>15.75</b> .620	1/BC	FG Braid-V w/Armor	<b>19.81</b> .780	.682	50	29.4	-55 +250	7000	Use RG 228A
118A	<b>4.78</b> BC .1880	PTFE	<b>15.75</b> .620	1/BC	FG Braid-V w/Armor	<b>19.81</b> .780	.682	50	29.4	-55 +250	7000	Use RG 228A
119	<b>2.59</b> BC .1020	PTFE	<b>8.43</b> .332	2/BC	FG Braid-V	<b>11.81</b> .465	.225	50	29.4	-55 +250	6000	Use up to 1000 MHz
120	<b>2.59</b> BC .1020	PTFE	<b>8.43</b> .332	2/BC	FG Braid-V	<b>13.28</b> .523	.282	50	29.4	-55 +250	6000	RG 119 w/Armor
122	<b>0.76</b> .0300 7/ <b>0.13</b> TC .0050	PE	<b>2.44</b> .096	1/TC	PVC-IIA	<b>4.06</b> .160	.016	50	29.4	-40 +80	1900	Use up to 1000 MHz
124	<b>0.64</b> TCCS .0253	Taped PTFE	<b>3.43</b> .135	1/TC	FG Braid-V	<b>6.1</b> .240	.210	73	20.3	-55 +250	2300	Use RG 140
125	<b>0.4</b> CCS .0159	Air-space PE	<b>11.68</b> .460	1/BC	PVC-IIA	<b>15.24</b> .600	.180	150	7.8	-40 +80	2000	Low Capacitance
126	<b>1.55</b> .0609 7/ <b>0.52</b> HR .0203	PTFE	<b>4.7</b> .185	1/HR	FG Braid-V	<b>7.11</b> .280	.070	50	29.4	-55 +250	3000	High Loss Cable



**Appendix D - Typical Coaxial Cable Specifications** (Continued)

RG/U Type Cable	Inner Conductor	Dielectric Material	DOD	Number/Type of Shielding Braids	Jacket Material	O.D.	Weight (lb/ft)	Nom. Imped. (Ohms)	Nom. Cap pf/ft	Max. Operating Temp. (C°)	Max. Operating Voltage (Volts RMS)	Comments
130	2 Cond. <b>2.17</b> .0855 7/ <b>0.72</b> BC .0285	PE	<b>11.99</b> .472	1/TC	PVC-I	<b>15.88</b> .625	.220	95	17.0	-40 +80	3000	RG 57 w/ Twisted Cond.
131	2 Cond. <b>2.17</b> .0855 7/ <b>0.72</b> BC .0285	PE	<b>11.99</b> .472	1/TC	PVC-I w/Armor	<b>17.35</b> .683	.290	95	17.0	-40 +80	3000	Armored RG 130
133	<b>0.72</b> BC .0285	PE	<b>7.24</b> .285	1/BC	PVC-I	<b>10.29</b> .405	.094	95	16.2	-40 +80	4000	Use RG 133A
133A	<b>0.64</b> BC .0253	PE	<b>7.24</b> .285	1/BC	PVC-IIA	<b>10.29</b> .405	.094	95	16.2	-40 +80	4000	95 Ohm Version RG 8
140	<b>0.64</b> SCCS .0250	PTFE	<b>3.71</b> 1.46	1/SC	FG Braid-V	<b>5.92</b> .233	.056	75	19.5	-55 +250	2300	See RG 302 for FEP Jacket
141	<b>0.91</b> SCCS .0359	PTFE	<b>2.95</b> .116	1/SC	FG Braid-V	<b>4.83</b> .190	.036	50	29.4	-55 +250	1900	Use RG 141A
141A	<b>0.99</b> SCCS .0390	PTFE	<b>2.95</b> .116	1/SC	FG Braid-V	<b>4.83</b> .190	.036	50	29.4	-55 +250	1900	See RG 303 for FEP Jacket
142	<b>0.91</b> SCCS .0359	PTFE	<b>2.95</b> .116	2/SC	FG Braid-V	<b>4.95</b> .195	.047	50	29.4	-55 +250	1900	Use RG 142A
142A	<b>0.99</b> SCCS .0390	PTFE	<b>2.95</b> .116	2/SC	FG	<b>4.95</b> .195	.047	50	29.4	-50 +250	1900	See RG 142B for FEP Jacket
142B	<b>0.99</b> SCCS .0390	PTFE	<b>2.95</b> .116	2/SC	FEP	<b>4.95</b> .195	.047	50	29.4	-55 +250	1900	Standard Center Cond. Available
143	<b>1.45</b> SCCS .0570	PTFE	<b>4.7</b> .185	2/SC	FG Braid-V	<b>8.26</b> .325	.114	50	29.4	-55 +250	3000	Use RG 143A
143A	<b>1.5</b> SCCS .0590	PTFE	<b>4.7</b> .185	1/SC	FG Braid-V	<b>8.26</b> .325	.109	50	29.4	-55 +250	3000	See RG 304 for FEP Jacket
144	<b>1.36</b> .0537 7/ <b>0.45</b> SCCS .0179	Air-space PE	<b>7.24</b> .285	Copper Tube	FG Braid-V	<b>10.41</b> .410	.137	75	19.5	-55 +250	5000	High Temp. RG 11A
145	2 Cond. <b>1.83</b> BC .0720	Air-space PTFE	—	1/BC	Lead/Tar	—	—	75	14.6	—	—	—
146	<b>0.18</b> CCS .0070	PE	<b>7.24</b> .285	1/BC	FG Braid-V	<b>9.53</b> .375	.108	190	6.0	-55 +200	1000	Low Capacitance
147	<b>6.35</b> BC .2500	PE	<b>23.11</b> .910	1/BC	PVC-I w/Armor	<b>49.2</b> 1.937	—	52	29.5	-40 +80	14,000	RG 19U w/Armor
148	<b>2.17</b> .0855 7/ <b>0.72</b> BC .0285	PTFE	<b>7.24</b> .285	1/SC	PVC-I w/Armor	<b>20.32</b> .800	—	52	29.5	-40 +80	4000	—
149	<b>1.22</b> .048 7/ <b>0.4</b> TC .0159	PE	<b>7.24</b> .285	1/BC	PVC-IIA	<b>10.29</b> .405	.105	75	20.6	-40 +80	5000	Use RG 391
150	<b>1.22</b> .048 7/ <b>0.4</b> TC .0159	PE	<b>7.24</b> .285	1/BC	PVC-IIA w/Armor	<b>11.76</b> .463	.112	75	20.6	-40 +80	5000	Use RG 392
156	<b>2.17</b> .0855 7/ <b>0.72</b> TC .0285	PE and Cond. PE	<b>7.24</b> .285	3/TC, GS, TC	PVC-IIA	<b>13.72</b> .540	.211	50	32.0	-40 +80	10,000	Triaxial Pulse Cable
157	<b>2.55</b> .1005 19/ <b>0.51</b> TC .0201	PE and Cond. PE	<b>11.56</b> .455	3/TC, GS, TC	PVC-IIA	<b>18.42</b> .725	.317	50	38.0	-40 +80	15,000	Triaxial Pulse Cable
158	<b>5.05</b> .1988 37/ <b>0.72</b> TC .0284	PE and Cond. PE	<b>11.56</b> .455	3/TC, GS, TC	PVC-IIA	<b>18.42</b> .725	.380	25	78.0	-40 +80	15,000	Triaxial Pulse Cable
159	<b>0.81</b> SC .0320	Taped PTFE	<b>2.95</b> .116	1/SC	FG Braid-V	<b>4.95</b> .195	.035	50	29.4	-55 +250	1900	Use RG 141
160	4 Cond. <b>1.8</b> .071 19/ <b>0.36</b> 2TC, 2BC .0142	PE	<b>8.18</b> .322	1/BC	PVC-I	<b>26.8</b> 1.055	—	125	12.0	-40 +80	3000	4 Cond. Balanced Line
161	<b>0.3</b> .012 7/ <b>0.1</b> S Cad. BR .004	PTFE	<b>1.45</b> .057	1/SC	Nylon	<b>2.08</b> .082	.015	70	20.0	-60 +120	1000	Miniature
164	<b>2.65</b> BC .1045	PE	<b>17.27</b> .680	1/BC	PVC-IIA	<b>22.1</b> .870	.490	75	20.6	-40 +80	10,000	RG 35B without Armor

**Appendix D - Typical Coaxial Cable Specifications (Continued)**

RG/U Type Cable	Inner Conductor	Dielectric Material	DOD	Number/Type of Shielding Braids	Jacket Material	O.D.	Weight (lb/ft)	Nom. Imped. (Ohms)	Nom. Cap pf/ft	Max. Operating Temp. (C°)	Max. Operating Voltage (Volts RMS)	Comments
165	2.44 .0960 7/0.81 SC .0320	PTFE	7.24 .285	1/SC	FG Braid-V	10.41 .410	.121	50	29.4	-55 +250	5000	RG 225 w/One Braid
166	2.44 .0960 7/0.81 SC .0320	PTFE	7.24 .285	1/SC	FG Braid-V w/Armor	11.68 .460	.144	50	29.4	-55 +250	5000	RG 165 w/ Armor
174	0.48 .0189 7/0.16 CCS .0063	PE	1.52 .060	1/TC	PVC	2.54 .100	.008	50	30.8	-40 +80	1500	Miniature Data Transmission
174A	0.48 .0189 7/0.16 CCS .0063	PE	1.52 .060	1/TC	PVC-IIA	2.54 .100	.008	50	30.8	-40 +80	1500	Miniature Data Transmission
176	3.43 .135 Helix over Magnetic Core	PE	7.24 .285	1/Magnet Wire	PVC-I	10.29 .405	.120	2240	49.0	-40 +80	5000	—
177	4.95 BC .195	PE	17.27 .680	2/SC	PVC-IIA	22.73 .895	.470	50	30.8	-40 +80	11,000	High Frequency RG 218
178	0.3 .0120 7/0.1 SCCS .0040	PTFE	0.91 .036	1/SC	KEL-F	1.83 .072	.0054	50	29.4	-40 +150	1000	Use RG 178B
178A	0.3 .0120 7/0.1 SCCS .0040	PTFE	0.86 .034	1/SC	KEL-F	1.83 .072	.005	50	29.4	-40 +150	1000	Use RG 178B
178B	0.3 .0120 7/0.1 SCCS .0040	PTFE	0.86 .034	1/SC	FEP-IX	1.83 .072	.0054	50	29.4	-55 +200	1000	High Strength Cond. Available
179	0.3 .0120 7/0.1 SCCS .0040	PTFE	1.45 .057	1/SC	KEL-F	2.54 .100	.010	70	20.4	-55 +150	1200	Use RG 179B
179A	0.3 .0120 7/0.1 SCCS .0040	PTFE	1.6 .063	1/SC	KEL-F	2.54 .100	.010	75	19.5	-40 +150	1200	Use RG 179B
179B	0.3 .0120 7/0.1 SCCS .0040	PTFE	1.6 .063	1/SC	FEP-IX	2.54 .100	.010	75	19.5	-55 +200	1200	High Strength Cond. Available
180	0.3 .0120 7/0.1 SCCS .0040	PTFE	2.62 .103	1/SC	KEL-F	3.56 .140	.019	93	15.4	-40 +150	1500	Use RG 180B
180A	0.3 .0120 7/0.1 SCCS .0040	PTFE	2.59 .102	1/SC	KEL-F	3.56 .140	.019	95	15.4	-40 +150	1500	Use RG 180B
180B	0.3 .0120 7/0.1 SCCS .0040	PTFE	2.59 .102	1/SC	KEP-IX	3.56 .140	.019	95	15.4	-55 +200	1500	High Strength Cond. Available
181	2 Cond. 1.21 .0477 7/0.4 BC .0159	PE	5.33 .210	2/Individual Inner Common Outer BC	PVS-IIA	16.25 .640	.198	125	12.0	-40 +80	3500	Balanced Line
182	2 of 19/0.36 BC .0142 2 of 19/0.17 TC .0066	4 Cores PE	2/8.43 .332 2/3.71 .146	Each Core 1/BC Overall Shield 1/BC	PVC-IIA each PVC-I overall	26.8 1.055	—	125 each	12.0 each	-40 +80	2300 3000	Special 4 Coaxial
183	6.38 BC .2510	PS Helix	16.05 .632	Al. Tube	None	19.05 .750	.380	50	23.0	-40 +80	1800	See Times AM-5034S
185	0.08 [.0031] Mag. Wire Helix on PE Core	Air-Space PE	4.78 .188	1/Magnet Wire	PVC-IIA	7.16 .282	—	2000	—	-40 +80	—	Delay Line Cable

**Appendix D - Typical Coaxial Cable Specifications** (Continued)

RG/U Type Cable	Inner Conductor	Dielectric Material	DOD	Number/Type of Shielding Braids	Jacket Material	O.D.	Weight (lb/ft)	Nom. Imped. (Ohms)	Nom. Cap pf/ft	Max. Operating Temp. (C°)	Max. Operating Voltage (Volts RMS)	Comments
187	0.3 .0120 7/0.1 SCCS .0040	PTFE	1.52 .060	1/SC	PTFE	2.67 .105	.010	75	19.5	-55 +250	1200	Use RG 179B
187A	0.3 .0120 7/0.1 SCCS .0040	PTFE	1.52 .060	1/SC	PTFE	2.67 .105	.010	75	19.5	-55 +250	1200	Use RG 179B
188	0.51 .0201 7/0.17 SCCS .0067	PTFE	1.52 .060	1/SC	PTFE	2.67 .105	.011	50	29.4	-55 +250	1200	Use RG 316
188A	0.51 .0201 7/0.17 SCCS .0067	PTFE	1.52 .060	1/SC	PTFE	2.67 .105	.011	50	29.4	-55 +250	1200	Use RG 316
189	6.38 BC .2510	PS Helix	16.05 .632	2/SC	PE-III A	22.23 .875	.570	50	23.0	-55 +80	3500	Use RG 389
190	1.49 .0585 7/0.3 TC .0117	Rubber H, J	9.65 .380	3/TC, GS, TC	Neoprene VIII	17.78 .700	.353	50	50.0	-55 +80	15,000	—
191	12.32 TC Braid .485	Rubber H, J, H	27.05 1.065	3/TC, GS, GS	Neoprene VIII	37.08 1.460	1.469	25	85.0	-55 +80	15,000	—
192	26.8 GS Tube 1.055 TC Braid	Butyl Rubber	—	3/TC, GS, GS	Rubber	55.88 2.200	—	12.5	175.0	-55 +80	15,000 Peak	—
193	26.8 GS Tube 1.055 TC Braid	Silicone Rubber	—	3/TC, GS, GS	Rubber	53.34 2.100	—	12.5	159.0	-55 +80	30,000 Peak	—
194	26.8 GS Tube 1.055 TC Braid	Silicone Rubber	—	3/TC, GS, GS	Rubber w/ Al. Armor	49.4 1.945	—	12.5	159.0	-55 +80	30,000 Peak	—
195	0.3 .0120 7/0.1 SCCS .004	PTFE	2.59 .102	1/SC	PTFE	3.68 .145	.020	95	15.4	-55 +250	1500	Use RG 180B
195A	0.3 .0120 7/0.1 SCCS .004	PTFE	2.59 .102	1/SC	PTFE	3.68 .145	.020	95	15.4	-55 +250	1500	Use RG 180B
196	0.3 .0120 7/0.1 SCCS .004	PTFE	0.86 .034	1/SC	PTFE	1.83 .072	.006	50	29.4	-55 +250	1000	Use RG 178B
196A	0.3 .0120 7/0.1 SCCS .004	PTFE	0.86 .034	1/SC	PTFE	1.83 .072	.006	50	29.4	-55 +250	1000	Use RG 178B
197	7.62 BC .300	PS Helix	19.25 .758	22.23 [.875] OD Al. Tube	None	22.23 .875	.500	50	22.0	-55 +80	2400 Peak	—
198	2.9 BC .1140	PS Helix	10.69 .421	12.7 [.500] OD Al. Tube	PE	15.24 .600	.155	70	16.0	-55 +80	1300 Peak	—
199	5.31 BC .209	PS Helix	19.25 .758	22.23 [.875] OD Al. Tube	PE	25.78 1.015	.435	70	16.0	-55 +80	2400 Peak	—
200	OD-10.29 .405 ID-7.65 BC Tube .301	PS Helix	37.39 1.472	41.28 [1.625] OD Al. Tube	PE	44.83 1.765	.900	70	16.0	-55 +80	4600 Peak	—
209	4.8 .189 19/0.96 SC .0378	Air-Space PTFE	12.7 .500	2/SC	SR and Polyester-IV	18.42 .725	.432	50	25.0	-55 +150	3200	Low Loss RG 211A
210	0.64 SCCS .0253	Air-Space PTFE	3.71 .146	1/SC	FG Braid-V	6.15 .242	.040	93	13.5	-55 +250	750	High Temp. Low Capacitance
211	4.83 BC .1900	PTFE	15.75 .620	1/BC	FG Braid-V	18.54 .730	.641	50	29.4	-55 +250	7000	High Temp. High Power
211A	4.83 BC .1900	PTFE	15.75 .620	1/BC	FG Braid-V	18.54 .730	.641	50	29.4	-55 +250	7000	High Temp. High Power
212	1.44 SC .0556	PE	4.7 .185	2/SC	PVC-II A	8.43 .332	.083	50	29.4	-40 +80	3000	Use up to 10,000 MHz
213	2.26 .0888 7/0.75 BC .0296	PE	7.24 .285	1/BC	PVC-II A	10.29 .405	.099	50	30.8	-40 +80	5000	Use up to 1000 MHz

**Appendix D - Typical Coaxial Cable Specifications (Continued)**

RG/U Type Cable	Inner Conductor	Dielectric Material	DOD	Number/Type of Shielding Braids	Jacket Material	O.D.	Weight (lb/ft)	Nom. Imped. (Ohms)	Nom. Cap pf/ft	Max. Operating Temp. (C°)	Max. Operating Voltage (Volts RMS)	Comments
214	2.26 .0888 7/0.75 SC .0296	PE	7.24 .285	2/SC	PVC-IIA	10.0 .425	.126	50	30.8	-40 +80	5000	Use up to 10,000 MHz
215	2.26 .0888 7/0.75 .0296	PE	7.24 .285	1/BC	PVC-IIA w/Armor	11.76 .463	.121	50	30.8	-40 +80	5000	Armored RG 213
216	1.21 .0477 7/0.75 BC .0159	PE	7.24 .285	2/BC	PVC-IIA	10.8 .425	.114	75	20.6	-40 +80	5000	Use up to 1000 MHz
217	2.7 BC .106	PE	9.4 .370	2/BC	PVC-IIA	13.84 .545	.201	50	30.8	-40 +80	7000	Use up to 1000 MHz
218	4.95 BC .195	PE	17.27 .680	1/BC	PVC-IIA	22.1 .870	.460	50	30.8	-40 +80	11,000	Use up to 1000 MHz
219	4.95 BC .195	PE	17.27 .680	1/BC	PVC-IIA w/Armor	23.57 .928	.585	50	30.8	-40 +80	11,000	Armored RG 218
220	6.6 BC .260	PE	23.11 .910	1/BC	PVC-IIA	28.45 1.120	.740	50	30.8	-40 +80	14,000	Use up to 1000 MHz
221	6.6 BC .260	PE	23.11 .910	1/BC	PVC-IIA w/Armor	29.92 1.178	.925	50	30.8	-40 +80	14,000	Armored RG 220
222	1.41 .0556 High Res. Wire	PE	4.7 .185	2/SC	PVC-IIA	8.43 .332	.087	50	30.8	-40 +80	3000	High Attenuation
223	0.89 SC .035	PE	2.95 .116	2/SC	PVC-IIA	5.36 .211	.034	50	30.8	-40 +80	1900	Use up to 10,000 MHz
224	2.609 BC .106	PE	9.4 .370	2/BC	PVC-IIA w/Armor	15.32 .603	.310	50	30.8	-40 +80	7000	Armored RG 217
225	2.38 .0936 7/0.79 SC .0312	PTFE	7.24 .285	2/SC	FG Braid-V	10.92 .430	.180	50	29.4	-55 +250	5000	See RG 393 for FEP Jacket
226	3.23 .1270 19/0.65 SC .0254	Taped PTFE	9.4 .370	2/SC	FG Braid-V	12.7 .500	.445	50	29.4	-55 +250	7000	—
227	2.38 .0936 7/0.79 SC .0312	PTFE	7.24 .285	2/SC	FG Braid-V w/Armor	12.40 .488	.198	50	29.4	-55 +250	5000	Armored RG 225
228	4.83 BC .1900	PTFE	15.75 .620	1/BC	FG Braid-V w/Armor	20.02 .788	.682	50	29.4	-55 +250	7000	Armored RG 211
228A	4.83 BC .1900	PTFE	15.75 .620	1/BC	FG Braid-V w/Armor	20.02 .788	.682	50	29.4	-55 +250	7000	Armored RG 211A
229	2.44 .0960 7/0.81 SC .032	PTFE	7.24 .285	1/SC	FG Braid-V w/Armor	11.68 .460	.144	50	29.4	-55 +250	5000	Use RG 166
230	5.05 .1988 37/0.72 TC .0284	Rubber-D	11.56 .455	3/TC, GS, GS	Rubber-IV	18.8 .740	—	25	100.0	-40 +80	15,000	—
231	OD-4.11 .162 ID-2.84 BC .112	Foam PE	11.43 .450	12.7 .500 OD Al. Tube	None	12.7 .500	.118	50	25.0	-55 +80	5000 Peak	RG 331 for Jacketed Cable
232	7.62 BC .300	PE Helix	19.25 .758	22.23 .875 OD Al. Tube	PE-IIIA	28.07 1.015	.570	50	22.0	-50 +80	2400 Peak	—
233	OD-15.01 BC .591 ID-12.22 .481	PS Helix	37.39 1.472	41.28 1.625 OD Al. Tube	PE-IIIA	44.83 1.765	1.050	50	22.0	-55 +80	4700 Peak	—
234	OD-29.39 BC 1.570 ID-25.78 1.015	PS Helix	70.49 2.775	79.38 3.125 OD Al. Tube	PE-IIIA	83.69 3.295	3.110	50	22.0	-55 +80	8700 Peak	—
235	2.16 .0852 7/0.72 .0284	Taped PTFE	5.72 .255	2/SC	SIL/DAC VI	11.43 .450	.160	50	29.5	-55 +250	5000	RG 115A 235 w/VI Jacket

**Appendix D - Typical Coaxial Cable Specifications (Continued)**

RG/U Type Cable	Inner Conductor	Dielectric Material	DOD	Number/Type of Shielding Braids	Jacket Material	O.D.	Weight (lb/ft)	Nom. Imped. (Ohms)	Nom. Cap pf/ft	Max. Operating Temp. (C°)	Max. Operating Voltage (Volts RMS)	Comments
236	4.11 BC .1620	PS Helix	10.69 .421	12.7 [.500] OD Al. Tube	None	12.7 .500	.165	50	24.0	-55 +80	1300 Peak	—
237	4.11 BC .1620	PS Helix	10.69 .421	12.7 [.500] OD Al. Tube	PE-III A	15.24 .600	.195	50	24.0	-55 +80	1300 Peak	—
238	—	—	—	—	—	—	—	—	—	—	—	Use RG 197/U
239	—	—	—	—	—	—	—	—	—	—	—	Use RG 232/U
240	OD-15.01 BC .591 ID-12.22 BC .481	PS Helix	36.07 1.420	41.28 1.625 OD Al. Tube	None	41.28 1.625	.930	50	22.0	-55 +80	4700	—
241	—	—	—	—	—	—	—	—	—	—	—	Use RG 233
242	OD-29.39 1.157 ID-25.78 1.0150	PS Helix	72.39 2.850	79.38 3.125 OD Al. Tube	None	79.3 3.125	2.700	50	22.0	-55 +80	8700 Peak	—
243	—	—	—	—	—	—	—	—	—	—	—	Use RG 234
244	2.59 BC .102	PS Helix	10.69 .421	12.7 [.500] OD Al. Tube	None	12.7 .500	.118	75	15.5	-55 +80	1200 Peak	—
245	2.59 BC .102	PS Helix	10.69 .421	12.7 [.500] OD Al. Tube	PE-III A	15.24 .600	.148	75	15.5	-55 +80	1200 Peak	—
246	4.78 BC .1880	PS Helix	19.25 .758	22.23 [.875] OD Al. Tube	None	22.23 .875	.348	75	15.2	-55 +80	2200 Peak	—
247	4.78 BC .1880	PS Helix	19.25 .758	22.23 [.875] OD Al. Tube	PE-III A	25.78 1.015	.418	75	15.2	-55 +80	2200 Peak	—
248	OD-9.5 BC .3740 ID-6.96 27.40	PS Helix	37.39 1.472	41.28 1.625 OD Al. Tube	None	41.28 1.625	.948	75	15.0	-55 +80	4300 Peak	—
249	OD-9.5 BC .3740 ID-6.96 27.40	PS Helix	37.39 1.472	41.28 1.625	PE-III A	44.83 1.765	1.068	75	15.0	-55 +80	4300 Peak	—
250	18.59 BC .732 16.05 .632	PS Helix	72.39 2.850	79.38 3.125 OD Al. Tube	None	79.38 3.125	2.395	75	15.0	-55 +80	8500 Peak	—
251	18.59 BC .732 16.05 .632	PS Helix	72.39 2.850	79.38 3.125 OD Al. Tube	PE-III A	32.95 2.805	.175	75	15.0	-55 +80	8500 Peak	—
252	4.24 BC .1670	PE Tubes	11.58 .456	13.46 [.530] OD Al. Tube	None	13.46 .530	.225	50	24.0	-55 +80	1000	—
253	4.24 BC .1670	PE Tubes	11.58 .456	13.46 [.530] OD Al. Tube	PE	16.64 .655	.655	50	24.0	-55 +80	1000	—
254	7.9 BC .3110	PE Tubes	21.16 .833	24.21 [.953] OD Al. Tube	PE	27.94 1.100	.555	50	24.0	-55 +80	1860	—
255	7.9 BC .3110	PE Tubes	21.16 .833	24.21 [.953] OD Al. Tube	None	24.21 .953	.550	50	24.0	-55 +80	1860	—
256	OD-7.9 SC .3110 ID-6.48 2550	PTFE Tubes	21.16 .833	24.21 .953 OD Al. Tube	None	24.21 .953	1.200	50	24.0	-55 +80	1860	—
257	OD-15.39 .6060 ID-1.23 BC .4860	PS Tubes	41.2 1.622	45.36 1.786 OD Al. Tube	None	45.36 1.786	1.380	50	24.0	-55 +80	3640	—
258	OD-15.39 .6060 ID-1.23 BC Tube .4860	PS Tubes	41.2 1.622	45.36 1.786 OD Al. Tube	PE	48.92 1.926	.100	50	24.0	-55 +80	3640	—
259	2.92 BC Tube .1150	PTFE Tubes	8.08 .318	9.91 [.390] OD Al. Tube	None	9.91 .390	.140	50	24.0	-55 +80	697	—
260	2.92 BC Tube .1150	PE Tubes	8.08 .318	9.91 [.390] OD Al. Tube	PE-III A	11.43 .450	.170	50	24.0	-55 +80	697	—
263	4.37 BC .1720	Air-Space PTFE	10.69 .421	Al. Tube	None	12.7 .500	.336	50	21.5	-40 +250	1300 Peak	—
264	4 Cond. 19/0.36 .0142 2 TC, 2 BC	PE	4.47 .176 e/core	2 TC, 2 BC BC Overall	PVC-II A	19.05 .750	.327	36.8	41.0	-40 +80	2000	Use RG 264C

**Appendix D - Typical Coaxial Cable Specifications (Continued)**

RG/U Type Cable	Inner Conductor	Dielectric Material	DOD	Number/Type of Shielding Braids	Jacket Material	O.D.	Weight (lb/ft)	Nom. Imped. (Ohms)	Nom. Cap pf/ft	Max. Operating Temp. (C°)	Max. Operating Voltage (Volts RMS)	Comments
264A	4 Cond. 19/0.36 .0142 2 TC, 2 BC	PE	4.47 .176 e/core	2 TC, 2 BC BC Overall	PUR	19.05 .750	.327	36.8	41.0	-40 +80	2000	Use RG 264C
264C	4 Cond. 1.73 .068 2 BC, 2 TC	PE	4.72 .186 e/core	2 TC, 2 BC BC Overall	PUR	19.43 .765	—	40	38.4	-40 +80	2000	Watertight 4 Coax.
265	17.2 BC Tube .6770	PE Helix	40.08 1.578	Copper Clad Mild Steel Tube	PE-III A	52.58 2.070	.120	50	22.3	-40 +80	145 KW Peak	—
266	0.29 Cond. Over .0113 3.66 Mag. Core .144	PE	7.24 .285	75 Spiral Wound Cond. 68 BC & 7 are Insulated	PVC-I	10.16 .400	—	1530	53.0	-40 +80	5000 DC	Delay Line Cable 50 ns/ft
267	9.02 BC Tube .3550	PS Helix	—	Copper Clad Mild Steel Cor. Tubing	PE-III A	30.23 1.190	.234	50	22.2	-40 +80	44 KW Peak	—
268	4.09 BC .1610	PE Helix	8.89 .350	Corrugated BC Tube	None	12.65 .498	.430	50	23.0	-55 +80	10 KW Peak	—
269	ID-7.29 .2870 OD-9.09 BC .3580 Tube	PE Helix	20.19 .795	Corrugated BC Tube	None	23.53 1.005	.430	50	22.2	-55 +80	44 KW Peak	—
269A	OD-7.29 .2870 ID-9.09 BC .3580 Tube	PE Helix	20.19 .795	Corrugated BC Tube	None	23.53 1.005	.875	50	22.2	-55 +80	44 KW Peak	—
270	ID-14.94 .5880 OD-17.48 BC .6880 Tube	PE Helix	40.08 1.578	Corrugated BC Tube	None	46.48 1.830	.875	50	22.3	-55 +80	145 KW Peak	—
270A	ID-14.94 .5880 OD-17.48 BC .6880 Tube	PE Helix	40.08 1.578	Corrugated BC Tube	None	46.48 1.830	.125	50	22.3	-55 +80	145 KW Peak	—
279	0.64 .0250 19/0.13 SCCS .0050	Air-space PTFE	2.79 .110	1/SC	FG Braid-V	3.68 .145	.200	75	19.5	-55 +250	Extra Flex. High Temp. Cable	Extra Flex. High Temp. Cable
280	2.91 BC .1144	Taped PTFE	8.31 .327	2/SC	FEP-IX	11.89 .468	.400	50	25.4	-55 +200	3000	Low Loss High Frequency
281	4.8 .1890 19/0.96 SC .0378	Taped PTFE	12.7 .500	2/SC	Sil./DAC-VI	19.05 .750	.031	50	25.4	-55 +150	4000	Low Loss High Power
282	0.64 SC .0253	Irradiated PE	2.51 .099	2/SC	FEP	5.08 .200	.145	54.5	28.2	-40 +150	4500	—
283	1.49 .0585 19/0.3 SC .0117	Rubber-D	7.31 .288	2/SC	Sil.	12.07 .475	.410	46	50.0	-55 +150	8000	—
284A	5.59 BC .220	PE Helix	20.19 .795	Corrugated BC Tube	None	25.53 1.005	.430	75	15.0	-55 +80	29 KW	—
285A	2.9 BC .1140	PTFE Helix	20.19 .795	Corrugated BC Tube	None	25.53 1.005	.720	100	13.0	-55 +200	22 KW Peak	—
286	OD-10.92 .4300 ID-9.14 BC .3600 Tube	PE Helix	39.88 1.570	Corrugated BC Tube	None	46.48 1.830	.750	75	15.1	-55 +80	100 KW Peak	—
287	5 BC .1970	PE Helix	39.88 1.570	Corrugated BC Tube	None	46.48 1.830	3.000	100	13.5	-55 +80	73 KW Peak	—
288	OD-8.46 .3330 ID-5.64 BC .2221 Tube	PE Helix	75.18 2.960	95.25 CCS 3.750	None	95.25 3.750	3.000	50	21.6	-40 +80	440 KW Peak	—
289	OD-20.83 .8200 ID-18.8 CCS .7400 Tube	PE Helix	75.18 2.960	95.25 CCS 3.750	None	95.25 3.750	1.040	75	14.7	-40 +80	290 KW Peak	—
292	10.92 BC Tube .4300	PE Helix	39.88 1.570	46.48 [1.8300] Corr. BC Tube	PE and Flooding Comp.	50.8 2.000	.160	75	15.1	-55 +80	100 KW Peak	—
293	2.69 BC .106	PE	9.53 .375	1/SC	PE-III A	13.84 .545	.160	50	30.8	-55 +80	7000	Use RG 293A

### Appendix D - Typical Coaxial Cable Specifications (Continued)

RG/U Type Cable	Inner Conductor	Dielectric Material	DOD	Number/Type of Shielding Braids	Jacket Material	O.D.	Weight (lb/ft)	Nom. Imped. (Ohms)	Nom. Cap pf/ft	Max. Operating Temp. (C°)	Max. Operating Voltage (Volts RMS)	Comments
293A	2.69 BC .106	PE	9.4 .370	1/SC	PE-III A	13.84 .545	.205	50	30.8	-55 +80	7000	Watertight RG 217
294	2 Cond. 2.05 .0808 1 BC, 1 TC	PE	11.99 .472	1/TC	PE-III A	16 .630	.205	95	16.3	-55 +80	3000	Use RG 294A
294A	2 Cond. 2.05 .0808 1 BC, 1 TC	PE	11.99 .472	1/SC	PE-III A	16 .630	.420	95	16.3	-55 +80	3000	Watertight RG 130
295	4.95 BC .1950	PE	17.27 .680	1/SC	PE-III A	22.73 .895	—	50	30.8	-55 +80	11,000	Watertight RG 218
296	5.97 .2352 37/0.85 SC .0336	Silicone Rubber	23.01 .906	1/SC	Neoprene	30.23 1.190	—	50	36.4	-55 +80	13,800	—
297	OD-9.02 .3550 ID-7.29 BC 2870 Tube	PTFE Helix	20.19 .795	Corrugated BC Tube	None	25.53 1.005	.090	50	21.4	-55 +200	44 KW Peak	—
298	15.32 .6030 7/0.51 CCS .0201	PE	2.92 .115	None	Foam PE	16.51 .650	.056	—	—	-55 +80	—	Buoyant Per MIL-C-22667
301	1.55 .0609 7/0.52 HR .0203	PTFE	4.7 .185	1/HR	FEP-IX	6.23 .245	.031	50	29.4	-55 +200	3000	FEP Jacketed RG 126
302	0.64 SCCS .0250	PTFE	3.71 .146	1/SC	FEP-IX	5.11 .201	.030	75	19.5	-55 +200	2300	FEP Jacketed RG 140
303	0.99 SCCS .0390	PTFE	2.95 .116	1/SC	FEP-IX	4.32 .170	.088	50	29.4	-55 +200	1900	FEP Jacketed RG 141A
304	1.5 SCCS .0590	PTFE	4.7 .185	2/SC	FEP-IX	7.11 .280	—	50	29.4	-55 +200	300	FEP Jacketed RG 143A
305	OD-10.92 .4300 ID-9.14 .3600 Tube	FEP	39.88 1.570	46.48 BC Tube 1.830	PE-III A	50.55 1.990	.545	75	14.4	-55 +80	2720	—
306A	4.39 BC .1730	Foam PE	20.35 .801	22.23 Al. Tube .8750	PE-III A	25.78 1.015	.070	75	16.5	-55 +80	5700	Per MIL-C-23806
307	0.74 .0290 19/0.15 SC .0058	Foam PE	3.71 .146	2/SC PUR Interlayer	PE-III A	6.86 .270	.070	75	16.7	-55 +80	1000	Triax Use to 100 MHz
307A	0.74 .0290 19/0.15 SC .0058	Foam PE	3.71 .146	2/SC PUR Interlayer	PE-III A	6.86 .270	.060	75	16.7	-55 +80	1000	Triax Use to 100 MHz
316	0.51 .0201 7/0.17 SCCS .0067	PTFE	1.52 .060	1/SC	FEDP-IX	2.59 .102	.012	50	29.4	-55 +200	1200	FEP Jacketed RG 188A
317	2 Cond. 2.21 .0870 7/0.74 BC .0290	FEP	11.33 .446	1/TC	Neoprene	18.03 .710	—	95	15.4	-55 +80	10,000	Water Blocked
318	OD-9.09 BC .3580 Tube ID-7.29 .2870	PE Helix	20.19 .795	25.53 1.005 Corr. BC Tube	PE-III A	28.58 1.125	.530	50	22.0	-55 +80	44 KW Peak	—
319	OD-17.48 BC .6880 Tube ID-14.94 .5580	PE Helix	39.88 1.570	46.48 1.830 Corr. BC Tube	PE-III A	50.8 2.000	1.040	50	22.0	-55 +80	145 KW Peak	—
321	OD-28.96 1.1400 Corr. BC Tube	PE Helix	—	79.39 2.850 Corr. BC Tube	None	72.39 2.850	1.210	50	21.7	-55 +80	320 KW Peak	—
322	OD-28.96 1.1400 Corr. BC Tube	PE Helix	—	79.39 2.850 Corr. BC Tube	PE & Flood Comp.	77.22 3.040	1.780	50	21.7	-55 +80	320 KW Peak	—



**Appendix D - Typical Coaxial Cable Specifications (Continued)**

RG/U Type Cable	Inner Conductor	Dielectric Material	DOD	Number/Type of Shielding Braids	Jacket Material	O.D.	Weight (lb/ft)	Nom. Imped. (Ohms)	Nom. Cap pf/ft	Max. Operating Temp. (C°)	Max. Operating Voltage (Volts RMS)	Comments
323	7.92 BC Tube .312	Foam PE	—	24.89 .980 Corr. BC Tube	PE & Flood Comp.	26.92 1.060	.420	50	25.6	-55 +80	1480	—
324	7.92 BC Tube .312	Foam PE	—	24.89 .980 Corr. BC Tube	None	24.89 .980	.320	50	25.6	-55 +80	1480	—
325	2.54 .1000 19/0.51 SC Al. .0200	PE Spline	6.6 .260	2/SC Strip Braids	PUR	8.89 .350	.10	50	26.3	-55 +80	750	Low Loss
326	5.08 .2000 19/1.02 SC Al. .0400	PE Spline	13.97 .550	2/SC Strip Braids	PUR	17.7 .697	.24	50	26.3	-55 +80	1700	Low Loss
327	8.13 .3200 19/1.63 SC Al. .0640	PE Spline	21.34 .840	2/SC Strip Braids	PUR	25.65 1.010	.55	50	26.3	-55 +80	2500	Low Loss
328	12.32 TC Braid .4850	Rubber H.J.H.	27.05 1.065	3/TC, GS, TC	Neoprene	37.08 1.460	1.469	25	85.0	-55 +80	20,000	—
329	1.49 .0585 19/0.3 TC .0117	Rubber H.J.H.	9.65 .380	3/TC, GS, TC	Neoprene	17.78 .700	.353	50	50.0	-55 +80	15,000	—
330	SC	Foam PE	—	1/SC	—	6.15 .242	—	50	25.0	—	—	—
331	4.11 BC .1620	Foam PE	11.43 .450	12.7 Al. Tube .500	PE-III A	15.24 .600	.187	50	25.0	-55 +80	2500	Jacketed 231 Solid Conductor
332	7.11 BC .2800	Foam PE	20.35 .801	22.23 Al. Tube .8750	None	22.23 .875	.466	50	25.0	-55 +80	4500	Per MIL-C-23806
333	7.11 BC .2800	Foam PE	20.35 .801	22.23 Al. Tube .8750	PE-III A	25.78 1.015	.548	50	25.0	-55 +80	4500	Jacketed RG 332
334	2.49 BC .0980	Foam PE	11.43 .450	12.7 Al. Tube .500	None	12.7 .500	.109	75	17.0	-55 +80	2500	Per MIL-C-23806
335	2.49 BC .0980	Foam PE	11.43 .450	12.7 Al. Tube .500	PE-III A	15.88 .625	.143	75	17.0	-55 +80	2500	Jacketed RG 334
336	4.39 BC .1730	Foam PE	20.35 .801	22.23 Al. Tube .8750	None	22.23 .875	.315	75	17.0	-55 +80	4000	Per MIL-C-23806
360	6.17 BC .2430	Foam PE	17.17 .676	19.05 Al. Tube .7500	PE-III A	20.95 .825	.397	50	25.0	-55 +80	4000	Per MIL-C-23806
366	4.06 .1600	Foam PE	—	13.72 .540 Corr. BC Tube	PE-III A	15.75 .620	—	50	62.6	-55 +80	4000	—
367	Corrugated BC Tube	PE Helix	—	12.7 .5000 Corr. BC Tube	PE-III A	132.08 5.2000	4.590	50	21.7	-55 +80	830 KW Peak	—
369	2.97 BC .1170	PE Tubes	8.08 .318	9.91 Al. Tube .390	PE-III A	11.94 .470	.140	50	24.0	-55 +80	700	—
370	2.97 BC .1170	PE Tubes	8.08 .318	9.91 Al. Tube .390	None	9.91 .390	.100	50	24.0	-40 +80	700	—
374	0.72 BC .0285	PE	4.06 .160	None	Foam PE	16.51 .650	.097	—	—	-55 +80	—	Buoyant Antenna
376	7.92 BC Tube .3120	Foam PE	—	Corr. Al. Tube	PE-III A	26.92 1.060	.390	50	26.0	-55 +80	6000	—
377	4.19 SC Tube .1650	PTFE Tubes	—	13.46 Al. Tube .5300	None	13.36 .530	.170	50	24.0	-55 +250	1000	—
378	18.11 BC Tube .7130	PE Helix	—	46.48 1.830 Corr. Al. Tube	PE-III A	50.8 2.000	.620	50	22.1	-55 +80	145 KW Peak	—
383	2 Cond. 1.02 .0403 2000 lb. Break	PE	—	None	Foam PE	16.51 .650	—	100	—	-55 +80	—	Exper. Buoyant Twisted Pair
384	1.29 BC .0508	PE	—	1/Flat BC Braid Waterproofed	Foam PE	16.51 .650	—	50	30.8	-55 +80	—	Buoyant Antenna 600 psig.
385	3.89 SC .1530	Semi-Solid PTFE	10.8 .425	12.7 Corr. Al. .500	Optional	16.76 .660	.178	50	25.0	-55 +250	1500	Low Loss No Press. Req.



**Appendix D - Typical Coaxial Cable Specifications (Continued)**

RG/U Type Cable	Inner Conductor	Dielectric Material	DOD	Number/Type of Shielding Braids	Jacket Material	O.D.	Weight (lb/ft)	Nom. Imped. (Ohms)	Nom. Cap pf/ft	Max. Operating Temp. (C°)	Max. Operating Voltage (Volts RMS)	Comments
386	1.29 CCS .0508	PE	—	None Non-hosing	Foam PE	16.51 .650	—	—	—	-55 +80	—	Buoyant Antenna 400 lb. Break
388	CS	PE	—	11.28 .444 Max. SC	PE-III A	13.84 .545	—	50	30.8	-55 +80	—	Watertight See RG 14A
389	6.35 BC Al. .2500	PE Spline	16.13 .635	2/SC	PE-III A	22.23 .875	.336	50	22.8	-55 +80	2000	Low Loss Replaces RG 189
391	1.22 .048 7/0.4 TC .0159	Cond. PE and PE	7.24 .285	1/TC	PVC-II A	10.29 .405	.092	72	—	-55 +80	5000	Low Noise Cable
392	1.22 .048 7/0.4 TC .0159	Cond. PE and PE	7.24 .285	1/TC	PVC-II A w/Armor	12.07 .475	.114	72	—	-55 +80	5000	Armored RG 391
393	2.38 .0936 7/0.79 SC .0312	PTFE	7.24 .285	2/SC	FEP-IX	9.91 .390	.165	50	29.4	-55 +200	5000	Moistureproof RG 225
397	2.44 .096 7/0.81 SC .032	Air-space PTFE	6.86 .270	2/SC	FEP-IX	8.89 .350	.125	50	28.0	-55 +200	2000	Low Loss RG 393
400	0.98 .0385 19/0.2 SPC .0077	PTFE	2.95 .116	2/SC	FEP-IX	4.95 .195	.050	50	29.3	-55 +200	1900	—
401	1.64 SPC .0645	PTFE	5.46 .215	6.35 OD .250 Copper Tube	None	6.35 .250	.081	50	29.3	-40 +125	3000	Semirigid
402	0.91 SCCS .0360	PTFE	3.02 .119	3.58 OD .141 Copper Tube	None	3.58 .141	.032	50	29.3	-40 +125	2500	Semirigid
403	0.3 SCCS .012 7/0.1 .004	PTFE	0.86 .034	2/SC FEP Interlayer	FEP-IX	2.95 .116	.0075	50	29.3	-55 +200	2500	Triaxial RG 178B
404	0.3 SCCS .012 7/0.1 .004	PTFE and Cond. PTFE	0.86 .034	1/SC	FEP-IX	1.83 .072	.0054	50	31.5 Max.	-55 +200	2000	Low Loss RG 178B
405	0.51 SCCS .0201	PTFE	1.68 .066	2.18 OD .086 Copper Tube	None	2.19 .0865	.015	50	29.4	-40 +125	1500	Semirigid

## Appendix E - Maximum Power Handling Capabilities for Cables

(Average Input Power in Watts)

RG/U Type Cable	Frequency in MHz								
	10	50	100	200	400	1,000	3,000	5,000	10,000
5, 5A, 5B	2,000	800	550	350	230	125	60	40	22
8, 8A, 10A, 213, 215	3,700	1,300	850	540	350	190	95	65	37
9, 9A, 9B, 214	3,700	1,300	850	540	350	190	95	65	37
11, 11A, 12, 12A, 13, 13A, 216	2,500	1,000	650	400	260	150	70	50	26
217	6,000	2,000	1,200	800	480	260	120	85	50
22, 22B	1,700	650	430	280	190	110	50	38	20
55, 55A, 55B, 223	800	310	205	137	90	53	28	20	10
58, 58B	730	280	180	125	85	50	25	17	—
58A, 58C	650	225	170	110	75	44	22	15	—
59, 59A, 59B	1,300	480	310	200	135	77	40	27	15
62, 62A, 71, 71A, 71B	1,300	480	310	200	135	77	40	27	15
62B	1,150	420	280	180	120	69	35	25	14
115, 115A, 165, 225, 393	25,000	9,500	6,300	4,300	2,800	1,700	880	620	350
108, 108A	340	145	100	70	50	30	15	—	—
122	540	205	140	90	60	35	18	12	—
140, 141, 141A, 142, 142B, 302, 303, 400, 402	9,000	3,500	2,400	1,600	1,100	650	350	245	140
143, 143A	11,500	4,600	3,200	2,100	1,450	850	460	330	190
144	25,000	9,500	6,300	4,300	2,800	1,700	880	620	350
161, 179, 179A, 179B, 187, 187A	1,600	780	570	420	310	200	110	76	41
174, 174A	170	72	50	36	25	16	—	—	—
178, 178A, 178B, 196, 196A	710	340	240	170	123	78	41	28	14
180, 180A, 180B, 195, 195A	2,500	1,100	800	570	400	250	135	93	50
188, 188A, 316	1,250	600	450	330	240	160	80	57	30
210	8,500	3,300	2,300	1,600	1,100	620	310	220	140

**Note:** Values above 3 GHz vary considerably depending on construction.

### Conditions

Ambient: 40°C

Altitude: Sea level

Center Conductor Temperature:

80°C for polyethylene

200°C for PTFE

## Appendix F - Nominal Loss Characteristics for Cables

(Decibels per Hundred Feet)

RG/U Type Cable	Frequency in MHz									
	10	50	100	200	400	1,000	3,000	5,000	10,000	
5, 5A, 5B	.80	1.40	2.90	4.30	6.40	11.00	22.00	30.00	52.00	
8, 8A, 10A, 213, 215	.66	1.50	2.20	3.20	4.60	9.00	19.00	28.00	47.00	
9, 9A, 9B, 214	.66	1.50	2.20	3.20	4.60	9.00	19.00	28.00	47.00	
11, 11A, 12, 12A, 13, 13A, 216	.66	1.50	2.20	3.20	4.60	9.00	19.00	28.00	—	
217	.41	1.00	1.40	2.10	3.10	5.80	13.00	19.00	31.00	
22, 22B	1.20	2.80	4.20	6.30	9.50	—	—	—	—	
55, 55A, 55B, 223	1.35	3.00	4.30	6.00	8.80	16.50	36.00	51.00	85.00	
58, 58B	1.20	3.10	4.60	7.00	10.00	17.50	38.00	—	—	
58A, 58C	1.40	3.30	4.90	7.30	11.00	20.00	41.00	—	—	
59, 59A, 59B	1.10	2.30	3.30	4.70	6.70	11.50	25.50	41.00	—	
62, 62A, 71, 71A, 71B	.90	1.90	2.80	3.70	5.20	8.50	18.40	29.50	—	
62B	.90	2.10	3.00	4.30	6.10	10.50	23.50	36.00	—	
115, 115A, 165, 225, 393	.60	1.40	2.10	3.10	4.50	7.50	14.00	21.00	35.00	
108, 108A	2.30	5.20	7.50	11.00	16.00	26.20	54.00	—	—	
122	1.60	4.40	6.90	11.00	16.60	29.20	57.20	89.00	—	
140, 141, 141A, 142, 142B, 302, 303, 400, 402	1.20	2.70	3.90	5.50	8.00	13.00	26.00	36.00	62.00	
143, 143A	.85	1.80	2.50	3.80	5.70	9.70	18.10	26.10	40.70	
144	.38	1.00	1.60	2.30	3.80	7.00	15.10	—	—	
161, 179, 179A, 179B, 187, 187A	5.00	7.90	9.80	12.70	15.80	25.00	43.00	62.50	135.00	
174, 174A	3.80	6.50	8.90	12.00	17.50	31.00	64.30	97.00	185.00	
178, 178A, 178B, 196, 196A	5.30	10.00	13.30	20.00	27.50	45.00	78.00	115.00	172.00	
180, 180A, 180B, 195, 195A	3.10	4.20	5.10	7.30	10.40	16.50	36.00	49.50	89.00	
188, 188A, 316	3.80	7.90	11.50	15.00	20.00	30.00	58.00	79.00	133.00	
210	.23	.58	.85	1.30	1.90	3.10	6.50	9.00	15.00	

**Note:** Values above 3 GHz vary considerably depending on construction.

**Conditions**

Ambient: 20°C

## Appendix G - Glossary of Terms

### A

**ambient** The atmospheric conditions surrounding a given item. Normally in terms of factors which influence or modify, such as temperature, humidity, etc.

**amplitude** The magnitude of variation in a changing quantity from its zero value. The word requires modification - as with adjectives such as peak, maximum, rms, etc. - to designate the specific amplitude in question.

**arc voltage** voltage that continues to pass through a surge protector during activation of GDT (approx. 20 volts)

**attenuation** A reduction in power. It occurs naturally during wave travel through lines, waveguides, space or a medium such as water. It may be produced intentionally by placing an attenuator in a circuit. The amount of attenuation is generally expressed in decibels per unit of length.

### B

**back mounted** A connector attached to the inside of a panel or box with its mounting flanges inside the equipment.

**bayonet coupling** A quick coupling device for plug and receptacle connectors. Pins projecting from the outside of the cylindrical receptacle engage with corresponding cam slots in the bayonet plug.

**bellmouth** Flared at the mouth. The rear of a properly crimped wire barrel will have a slight flare (bellmouth) to relieve the strain on the wire strands as they leave the area of high compression and take their natural "lay". A bellmouth condition may also be present in front of the wire barrel.

**black box** A term used to refer to any assembly or subassembly, usually electronic, that can readily be installed or removed from a larger system.

**BNC Connector** A radio frequency connector covered by Military Specification. It has an impedance of 50 or 75 ohms, and is designed to operate in the 0 to 4 GHz frequency range. It features quick connect/disconnect by pin and cam bayonet coupling.

**body** Main or largest portion of a connector to which other portions are attached.

**braid** A weave of metal fibers used as a shield covering for an insulated conductor or group of insulated conductors. When flattened it may be used as a grounding strap.

**broad-band E** Interference generated over a wide range of frequencies (e.g., automotive ignition noise).

**bulkhead** A term used to define a mounting style of connectors. Bulkhead connectors are designed to be inserted into a panel cutout from the rear (component side) of the panel.

### C

**cable** Either a standard conductor, with or without insulation and other coverings, or a combination of conductors insulated from each other.

**cable assembly** A completed cable and its associated hardware.

**capacitance** The property of an electrical conductor (dielectric in a capacitor) that permits the storage of energy as a result of electrical displacement. The basic unit of capacitance is the farad, however, measurement is more commonly in microfarads or picofarads.

**cavity** A metallic enclosure in some types of tubes and circuits within which resonant fields may be excited at the microwave frequency to which the cavity is tuned. Usually referred to as resonant cavity. See also: contact cavity.

**characteristic impedance** The ratio of voltage to current at any point along a transmission line on which there are no standing waves.

**circular mil area (CMA)** A unit of area equal to the area of a circle whose diameter is 1 mil (0.001 inch). Used chiefly in specifying cross-sectional areas of conductors. (See Tyco Electronics Brochure No. 4402-8, Computing Circular Mil Area for Tyco Electronics Terminals and Splices).

**closed entry contact** A female contact designed to prevent the entry of a pin or probing device having a cross-sectional dimension (diameter) greater than the mating pin.

**coaxial cable** A transmission line consisting of two conductors concentric with and insulated from each other. In its flexible form it consists of either a solid or stranded center conductor surrounded by a dielectric. A braid is then woven over the dielectric to form an outer conductor. A weatherproof plastic covering, usually vinyl, is placed on top of the braid.

**connector** A coupling device employed to connect conductors to one circuit with those of another circuit. Used to provide rapid connect/disconnect mating with pc boards, posts or another connector.

**connector assembly** Includes housing and contact plus additional components such as hardware used to hold the assembly together and/or make the assembly a functional connector.

**contact** An electrically conductive component designed for use in a multi-circuit connector.

**contact cavity** A defined hole in the connector insert or housing into which the contact must fit. See also: cavity.

**contact durability** The number of insertion and withdrawal cycles that a connector must be capable of withstanding while remaining within the performance levels of the applicable specification.

**contact engaging and separating force** Force required to either engage or separate contacts. Values are generally established for maximum and minimum forces.

**contact inspection hole** A hole, perpendicular to the cylindrical rear portion of screw machined contacts, used to check the depth to which wire has been inserted into the barrel.

**contact resistance** Measurement of electrical resistance of mated contacts when assembled in a connector under typical service use. Electrical resistance is determined by measuring from the rear of the electrical area of one contact to the rear of the contact area of the mating contact (excluding both crimps) while carrying a specified test current.

**contact shoulder** The flanged or enlarged portion of a contact that prevents it from being over-inserted into the appropriate contact cavity. The shoulder may also contribute to proper orientation and stability with the connector housing.

**contact, two-piece** A contact made of two separate parts joined by swedging, brazing or other means of fastening to form a single contact. While this provides the mechanical advantages of two metals, it also has the inherent electrical disadvantage of difference in conductivity.

**corona** A discharge of electricity appearing as a bluish-purple glow on the surface of, and adjacent to, a conductor when the voltage gradient exceeds a certain critical value. It is caused by the ionization of surrounding air by high voltage.

**crimp** The final configuration of a terminal barrel after the necessary compression forces have been applied to cause a functional union between the terminal barrel and the wire.

**crimp height** A top to bottom measurement of the crimped barrel, using a crimp height comparator in the prescribed manner. (Refer to Tyco Electronics Instruction Sheet 7424).

**crimping dies** A term used to identify the shaping tools that, when moved toward each other, produce a certain desirable shape to the barrel of the terminal or contact that has been placed between them. Crimping dies are often referred to as die sets or as die inserts.

## Appendix G - Glossary of Terms (Continued)

**crimping head** Tooling containing jaws and linkage for use in pneumatic or hydraulic powered units to crimp loose-piece contacts/terminals that may be too large for hand tool applications.

**crimping tool** A term commonly used to identify a hand held mechanical device that is used to crimp a contact, terminal or splice.

**crosstalk** A magnetic or electrostatic coupling which causes the unwanted transfer of energy from one circuit (disturbing circuit) to another circuit (disturbed circuit)

**current rating** The maximum continuous electrical flow of current recommended for a given situation. It is expressed in amperes.

**cycle** One complete sequence of values of an alternating quantity, including a rise to maximum in one direction and return to zero; a rise to maximum in the opposite direction and return to zero. The number of cycles occurring in one second is called the frequency.

### D

**daisy chain** A cable assembly with common wires jumpering three or more connections/connectors. The term is also used as a verb, implying to connect in jumper manner.

**dB** Abbreviation — see decibel.

**D.C. sparkover voltage** defined as the maximum voltage across a device before it discharges the energy to ground when subjected to a slowly rising voltage ramp. A rate of rise of 100V/s is usually chosen for testing purposes.

**decibel** A unit expressing the ratio of two voltages, currents or powers. It is equal to 20 times the common logarithm of the ratio of two voltages across or two currents through equal loads, or 10 times the common logarithm of the two powers. One decibel is approximately the smallest change in audible power that can be recognized by the human ear.

**die closure** Term used to designate a crimping area (crimping chamber) when the dies are fully closed or bottomed. Die closure is checked with go/no go plug gage to insure that the crimp produced by the tooling satisfies the crimp height specification.

**dielectric** A material that serves as an insulator. The amount of resistance to voltage in a given insulation.

**dielectric withstanding voltage** The maximum potential gradient that a dielectric material can withstand without failure.

**discontinuity** Rated interconnection: a broken connection (open circuit) or the loss of a specified connection characteristic. Transient phenomena: Short term (temporary) interruption or unacceptable variation in current or voltage.

**dissipation** Unusable or lost energy, such as the production of unused heat in a circuit.

**distortion** An unwanted change or addition to a signal or waveform when it is amplified. This definition excludes noise which is an extraneous signal superimposed on the desired signal.

**dummy load** A dissipative device used at the end of a transmission line or waveguide to convert transmitted energy into heat, so essentially no energy is radiated outward or reflected back to its source.

**dust cap** A device attached to a connector to provide protection against dust and foreign debris.

### E

**electromagnetic compatibility (EMC)** The ability of an electronic device to operate in its intended environment without its performance being affected by EMI and without generating EMI that will affect other equipment.

**electromagnetic interference (EMI)** Unwanted electrical or electromagnetic energy that causes undesirable responses, degrading performance or complete malfunctions in electronic equipment. See also: noise.

**electromotive force (emf)** See voltage.

**environmentally sealed** A unit is provided with gaskets, seals, grommets, potting or other means to keep out moisture, dust, air or dirt which might reduce or impair its performance.

### F

**feedthrough** A connector or terminal block, usually having double-ended terminals, which permits distribution and bussing of electrical circuits. Also used to describe a bushing in a wall or bulkhead, separating compartments at different pressure levels, with terminations on both sides.

**ferrule** A short tube used to make solderless connections to shielded or coaxial cable. Also molded into the plastic inserts of multiple contact connectors to provide strong, wear-resistant shoulders on which contact retaining springs can bear.

**flange** A projection extending from or around the periphery of a connector and having holes that provide for mounting the connector to a panel or to a mating connector.

**frequency modulation (fm)** A scheme for modulating a carrier frequency in which the amplitude remains constant but the carrier frequency is displaced in frequency proportionally to the amplitude of the modulating signal. An fm broadcast is practically immune to atmospheric and man-made interference.

**fretting corrosion** A form of accelerated oxidation that appears at the interface of contacting materials undergoing slight cyclic relative motion. All non-nobel metals (tin) are susceptible to some degree of fretting corrosion and will suffer contact resistance increases.

**front mounted** A connector is said to be front mounted when it is attached to the outside of the mating side of a panel. A front mounted connector can only be installed or removed from the outside of the equipment.

### G

**gas discharge tube (GDT)** hermetically sealed device containing an inert gas.

**GHz** See gigahertz.

**giga** A prefix meaning one billion (10<sup>9</sup>).

**gigahertz (GHz)** One billion cycles per second (10<sup>9</sup> cps).

**glow mode** condition in which the GDT continues to conduct after an impulse passed. Characterized by a visible glow in the device caused by over-heating.

**ground** A connection, intentional or accidental, between an electrical circuit and the earth or some conducting body (e.g. chassis) serving in place of earth.

### H

**heat-shrinkable** A type of plastic material that has been cross-linked. A term describing tubes, sleeves, caps, boots, films or other forms of plastic which shrink to encapsulate, protect or insulate connections, splices, terminations and other configurations.

**hermetic** Airtight, impervious to external influence, as in a hermetic package. Often used to describe metal-to-metal solder or weld-sealed packages.

**Appendix G - Glossary of Terms (Continued)**

**hermetic seal** Hermetically sealed connectors are usually multiple contact connectors where the contacts are bonded to the connector by glass or other materials and permits maximum leakage rate of gas through the connector of 1.0 micron ft./hr. at one atmosphere pressure for special applications.

**hertz (Hz)** International standard term for cycles per second. Named after the German physicist Heinrich R. Hertz (e.g., 60 cycles per second is equal to 60 hertz or 60 Hz).

**I**

**impedance (Z)** The total opposition offered by a component or circuit to the flow of alternating or varying current. Impedance is expressed in ohms and is similar to the actual resistance in a direct current circuit. In computations, impedance is handled as a complex ratio of voltage to current.

**impedance match** A condition in which the impedance of a component or circuit is equal to the internal impedance of the source, or the surge impedance of a transmission line. This gives maximum transfer of energy from the source to the load, as well as minimum reflection and distortion.

**impulse discharge current** is defined as the peak current of an impulse which the device can withstand ten times (5 of each polarity at fixed time intervals) without substantially affecting device performance. The test normally used to determine this capacity uses the 8/20ms waveform as depicted below where  $T_1=8\text{ms}$  and  $T_2=20\text{ms}$ .

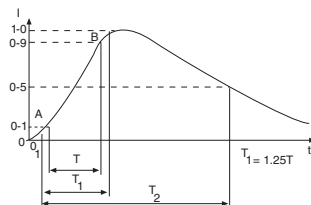

**impulse sparkover voltage** defined as the maximum level of voltage across a device before it discharges the energy to ground when subjected to a voltage impulse. The three common waveform profiles used to determine this capacity are:

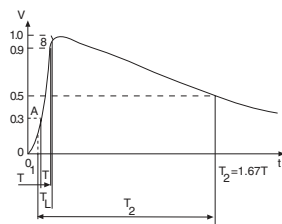

**inductance** One cause of reactance. An electromagnetic phenomenon in which the expanding and collapsing of a magnetic field surrounding a conductor or device tends to impede changes in current. The effects of inductance become greater as frequencies increase. The basic unit for inductance is the henry.

**input impedance** The impedance that exists between the input terminals of an amplifier or transmission line when the source is disconnected. The circuit, signal level and frequency must be specified.

**insertion loss** The loss in load power due to the insertion of a component, connector or device at some point in a transmission system. Generally expressed in decibels as the ratio of the power received at the load before insertion of the apparatus, to the power received at the load after insertion.

**insulation crimp** The area of a terminal splice or contact that has been formed around the insulation of a wire.

**insulation grip** The ability of certain crimped terminals to hold firmly in place both the conductor and a small portion of insulation. This prevents the conductor from being exposed due to insulation receding away from the terminal.

**insulation resistance** The electrical resistance between two conductors separated by an insulating material.

**interface** The two surfaces of a multiple-contact connector that face each other when the connector is assembled.

**interference** An electrical or electromagnetic disturbance that causes undesirable response in electronic equipment.

**J**

**jack** A connecting device into which a plug can be inserted to make circuit connections. The jack may also have contacts which open or close to perform switching functions when the plug is inserted or removed. See also: receptacle.

**L**

**line impedance** Impedance as measured across the terminals of a transmission line; frequently the characteristic impedance of the line.

**M**

**matched impedance** The coupling of two circuits in such a way that the impedance of one circuit equals the impedance of the other.

**mate** To join two connectors in a normal engaging mode.

**maximum discharge current** defined as the peak current of an impulse which the device can withstand once without substantially affecting device performance.

**mega (M)** A prefix meaning one million ( $10^6$ ).

**microwave** That portion of the electromagnetic spectrum lying between the far infrared and conventional radio frequency range. The microwave frequency range extends from 1 GHz to 300 GHz. Microwaves are usually used in point-to-point communications because they are easily concentrated into a beam.

**Military Specification** Military requirements. The demand imposed upon a system to meet a military operational need.

**mismatch** The condition in which the impedance of a source does not match or equal the impedance of the connected load. This reduces power transfer by causing reflection.

**N**

**narrow-band** EMI generated from a device operating at a specific and limited range of frequencies. See also: electromagnetic interference (EMI).

**N Connector** A large radio frequency connector covered by Military Specification. It has an impedance of 50 ohms and is designed to operate in the 0 to 11 GHz frequency range. It has a threaded coupling and is physically larger than a TNC connector.

**noise** An extraneous signal in an electrical circuit, capable of interfering with the desired signal. Classes of noise include burst of popcorn noise, intermediate frequency noise at low audio frequencies, white (thermal) noise, etc. Signals from power supply or ground line coupled into an amplifier output may be considered noise.

**O**

**“O” crimp** An insulation support crimp for open barrel terminals and contacts. In its crimped form it resembles an “O” and conforms to the shape of the round wire insulation. “O” crimp is also used to describe the circumferential crimps used on COAXICON ferrules.



## Appendix G - Glossary of Terms (Continued)

**ohm** The unit of measurement for electrical resistance. A circuit is said to have a resistance of one ohm when an applied emf of one volt causes a current of one ampere to flow.

### P

**panel mount** A method of fixing a connector to a board, panel or frame. The mounted connector is usually the receptacle or female connector. The plug or male connector is usually the removable portion.

**pcb** Abbreviation: see printed circuit board.

**permeability (chemical)** The passage or diffusion (or rate of passage) of a gas, vapor, liquid or solid through a barrier without physically or chemically affecting it.

**permeability (magnetic)** The measure of how much better a material is than air as a path for magnetic lines of force. Air is assumed to have a permeability of 1.

**plug** In coaxial RF connectors the plug is usually the movable portion, and is usually attached to a cable or removable assembly. Plugs mate with receptacles, jacks, outlets, etc.

**printed circuit board** An insulating board serving as a base for a printed circuit. When the printing process is completed, the board may include printed components, as well as printed wiring.

**propagation delay** Time required for an electronic digital device, or transmission network to transfer information from its input to its output.

**propagation delay time** The time between the application of a digital input waveform and the corresponding change in input waveform. It is measured between reference points on the waveforms. The time is generally different for positive-going and negative-going waveforms.

**prototype** A model suitable for use in the complete evaluation of form, design and performance.

**pulse** A change in the level, over a relatively short period of time, of a signal whose value is normally constant.

**pulse width** The length of time that the pulse voltage is at the transient level. Electronic pulse widths are usually in the millisecond ( $10^{-3}$ ), microsecond ( $10^{-6}$ ) or nanosecond ( $10^{-9}$ ) range.

### R

**receptacle** In coaxial RF connectors, the receptacle is usually the fixed or stationary portion that is mounted to the panel. In shell-type, multiple-contact connectors the receptacle usually contains the pin contacts and is mounted on the "cold" side of a circuit such as in a drawer or black box. Receptacles mate with plugs. See also: jack.

**residual impulse** defined as the voltage that will pass through the device prior to activation of the GDT.

**residual voltage** defined as the small amount of voltage left on the line after an impulse passes.

**resonance** A frequency at which capacitive reactance and inductive reactance are equal and therefore cancel one another's effects.

**RF** Abbreviation for radio frequency.

**RG/U** Symbol used to designate coaxial cables that are made to Government Specification (e.g., RG 58U; in this designation the "R" means radio frequency, the "G" means Government, the "58" is the number assigned to the government approval, and the "U" means it is a universal specification).

**rise time** The time required for a component or logic circuit to change from the quiescent to the transient state when an input is applied. (i.e. elapsed time between application of input and attainment of full output level).

**rms** Abbreviation for root mean square.

**root mean square** The effective value of an alternating current, corresponding to the direct current value that will produce the same heating effect.

### S

**screw machine contact** A contact which is machined from solid bar stock.

**semi-rigid** A cable containing a flexible inner core and a relatively inflexible sheathing.

**sheath** The outer covering of a jacket over the insulated conductors to provide mechanical protection for the conductors. Also known as the external conduction surface of a shielded transmission line.

**shield/shielding (cable)** A conducting envelope, composed of metal strands, which enclose a wire, group of wires or cable so constructed that substantially every point on the surface of the underlying insulation is at ground potential or at some predetermined potential with respect to ground.

**shield/shielding (circuit)** The metal sleeving surrounding one or more of the conductors in a wire circuit to prevent interference, interaction or current leakage. Shielding protects a circuit against crosstalk.

**shock (mechanical)** (1) An abrupt impact applied to a stationary object. (2) An abrupt or nonperiodic change in position, characterized by suddenness, and by the development of substantial internal forces.

**SHV** Abbreviation for standard high voltage.

**sine wave** A wave which can be expressed as the sine of a linear function of time, space or both. A waveform, often viewed on an oscilloscope, of a pure alternating current or voltage.

**skin effect** The tendency of alternating currents to flow near the surface of the conductor, thus being restricted to a small part of the total cross-sectional area. This effect increases the resistance and becomes more marked as the frequency rises.

**sleeve** The insulated or metallic covering over the barrel of a terminal.

**solder contact** A contact or terminal having a cup, hollow cylinder, eyelet or hook to accept a wire for a conventional soldered termination.

**standard high voltage (SHV)** A quick connect/disconnect connector series employing a bayonet lock coupling and designated to operate safely up to 5000 volts AC. It is the industry standard connector specified by the National Bureau of Standards (NBS) for high voltage use by the Atomic Energy Commission (AEC).

**standing-wave** Distribution of current and voltage on a transmission line, resulting from two sets of waves traveling in opposite directions.

**standing wave ratio** The ratio between maximum and minimum current or voltage along a line. It is a measure of the mismatch between the load and the line. It is equal to 1 when the line impedance is perfectly matched to the load. (In which case the maximum and minimum are the same, as current and voltage do not vary along the line). The perfect match would be a 1 to 1 ratio.

**super high frequency (shf)** The Federal Communications Commission designation for the band from 3,000 to 30,000 MHz in the radio spectrum.

### T

**tensile** The amount of axial load (longitudinal stress) required to break or pull the wire from the crimped barrel of the terminal, splice or contact.

## Appendix G - Glossary of Terms (Continued)

**tensile strength** The greatest longitudinal stress that a substance or union can bear without tearing or pulling apart. In crimped terminations, it is the greatest longitudinal stress that a terminal can bear without the wire separating from the terminal.

**thermal shock** The effect of heat or cold applied at such a rate that nonuniform thermal expansion or contraction occurs within a given material or combination materials. The effect can cause inserts and other insulation materials to pull away from metal parts.

**time-delay** A circuit that delays the transmission of an impulse for a definite and desired period of time.

**TNC Connector** A radio frequency connector covered by Military Specification. It has an impedance of 50 ohms and is designed to operate in a 0 to 11 GHz frequency range. Reliability is assured by a threaded coupling that can be safely wired to prevent accidental disconnect.

### U

**UG** Symbol used to describe coaxial connectors that were made to a Government specification. This specification is now obsolete.

**ultra-high frequency (uhf)** A Federal Communications Commission designation for the band from 300 to 3000 MHz on the radio spectrum. In television - channels 14 to 83 or 470 to 890 MHz.

### V

**very high frequency (vhf)** A Federal Communications Commission designation for the band from 30 to 300 MHz on the radio spectrum.

**voice-frequency (vf)** Any frequency within that part of the radio frequency range essential to speech transmission of a commercial quality (i.e., 300 to 3400 Hz). Also referred to as telephone frequency.

**volt (V)** The unit of measurement for electromotive force (emf). It is equivalent to the force required to produce 1 ampere through a resistance of 1 ohm.

**voltage (E)** The term most often used to designate electrical pressure that exists between two points and is capable of producing a flow of current when a closed circuit is connected between the two points. Voltage is measured in volts, millivolts, microvolts and kilovolts. The terms electromotive force (emf), potential, potential difference and voltage drop are often referred to as voltage.

**voltage drop** The voltage developed across a component or conductor by the flow of current through the resistance or impedance of that component or conductor.

**voltage hold over** refers to the maximum line voltage at which recovery of the GDT to its inactive state will take place within a specified period of time (normally 150ms) after an induced lightning pulse (normally 10/1000ms) has been applied.

**VSWR** Abbreviation for voltage standing wave ratio. Also see: standing wave ratio.

### W

**wavelength** The distance between two points which are in phase on adjacent waves. It is the distance traveled by the wave in the same span of one cycle. Electromagnetic waves (both light and radio) have a speed in space of about 300,000,000 meters (186,000 miles) per second. Thus wavelength in meters is equal to 300,000,000 divided by frequency.

### Z

**Z** Letter symbol used to represent impedance in ohms.



**RF Coaxial Solutions for Communications Equipment**

**Wireless  
Base Station**



**Carrier Rack  
Equipment**



**Chassis**



**Set Top Box**

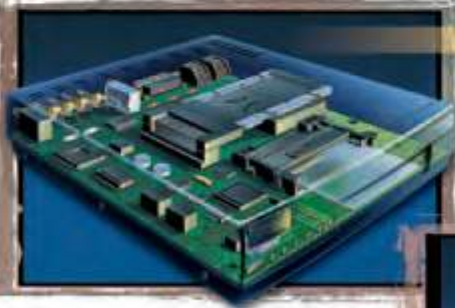

**NIC Card**



## Wireless Base Station

Radio base station cabinets demand packaging that combines high power r.f. signals, high speed digital data, and analog signals. Cabinet input/output connections are provided by N Series and 7/16 connectors. Plug-in r.f. modules require Blindmate, DIN inserts, and

panel mount connectors. Transceiver modules utilize MCX, and SSMT board and cable connectors for board to board and panel to board applications. Finally, both semi-rigid and flexible RG cable assemblies route signals throughout the entire cabinet.

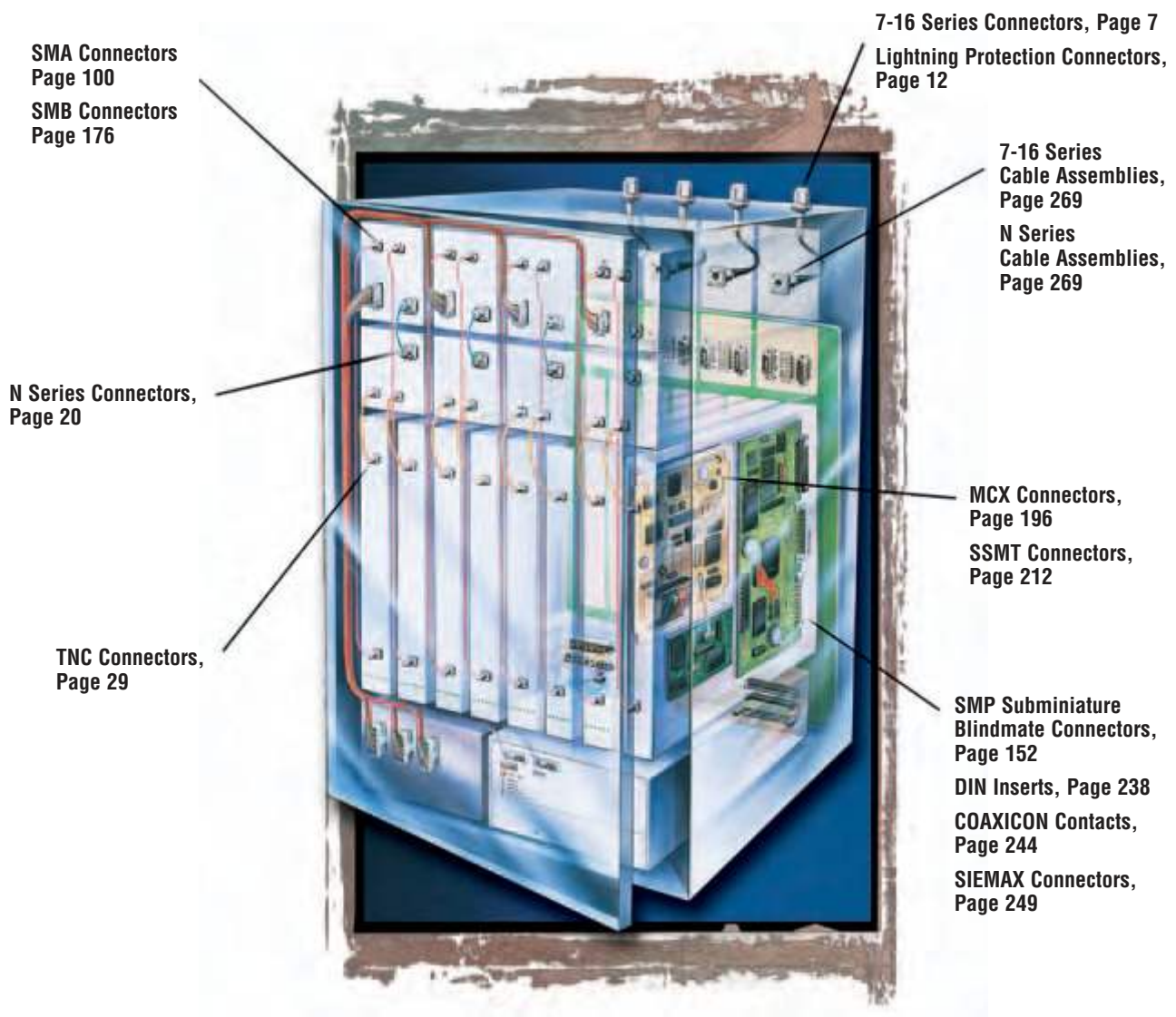

## Carrier Rack Equipment

For today's fast paced Carrier Equipment market, Tyco Electronics offers a broad line of RF interconnect products that meet demanding customer requirements for CATV, telecom and data transmission applications. Connectors, cable assemblies, and applicator tooling are available for applications ranging from central office to customer premise environ-

ments, 50 or 75 ohms, from rack based equipment to set top boxes. Styles range from standard miniature RF connectors such as F series, BNC and TNC to subminiature RF connectors such as SMA, SMB, SMC and Blindmate connectors, to Micro miniature MMCX, SSMT and SMT/QuickGrip products. SIEMAX connectors provide multi-positional surface mount technology

RF connection for pcb and panel applications, and offer superior packaging density. Between Series adapters are available, along with connectors meeting international DIN and IEC standard interfaces. High performance GHz range BNC connectors meet the needs for faster signaling.

**G Series Connectors,  
Page 98**

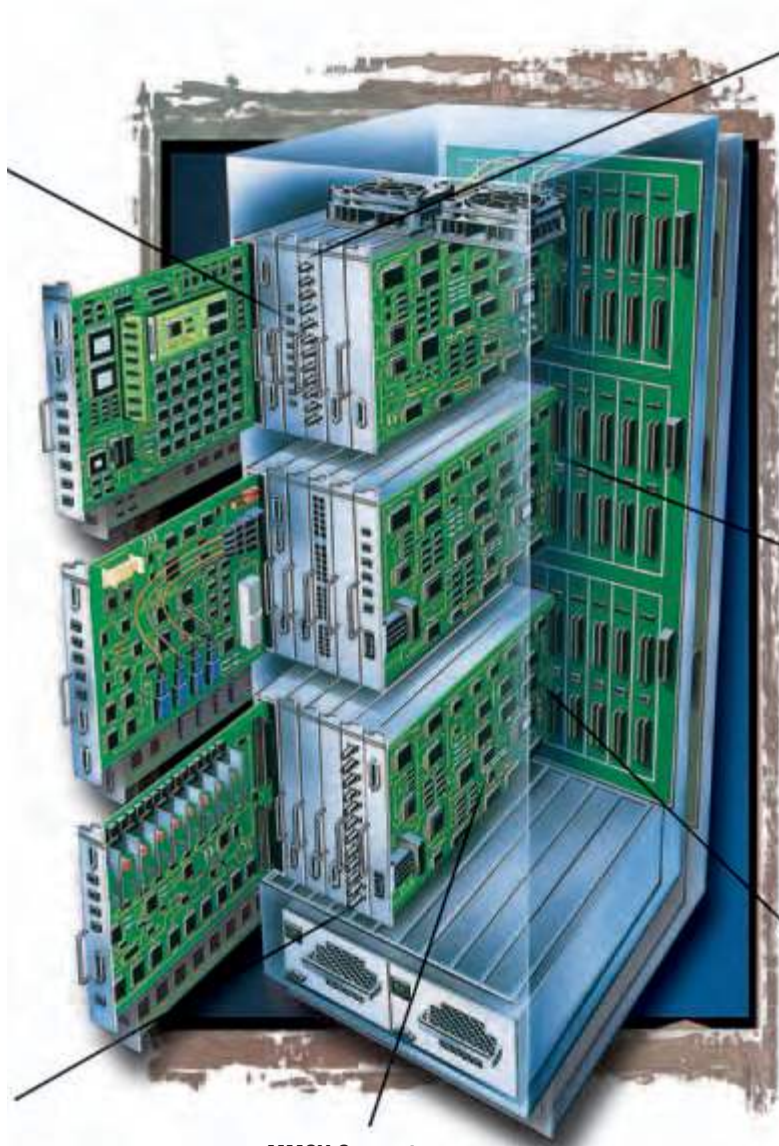

**BNC Connectors,  
Page 44**

**SMA Connectors,  
Page 100**

**SMB Connectors,  
Page 176**

**TNC Connectors,  
Page 29**

**DIN Inserts, Page 238**

**SIEMAX Connectors,  
Page 249**

**F Series Connectors,  
Page 93**

**MMCX Connectors,  
Page 218**



## Chassis, NIC Card and Set Top Box

Coaxial interconnects have evolved in the enterprise market place over the years. The BNC interfaces that once dominated the Ethernet premise installations to coax products that provide high speed access to the carrier infrastructure.

In today's environment, Network Interface Cards (NIC) still feature Capacitively Decoupled BNC connectors with built-in chip capacitors to reduce

noise and ground loop currents.

For the infrastructure, the standard coaxial interfaces to the infrastructure include both 50 and 75 ohm BNC connectors. The BNC family features numerous styles including cable plugs and jacks, adapters and printed circuit board connectors. To address manufacturability, we offer the board mount in SMT, wave solder, and press fit. More recently, the

SMB interface is the one of choice for improved density and is available in both commercial and MIL-type. Again, our portfolio has a wide variety of configurations to address your system requirements.

Lastly, as broadband CATV becomes more prevalent for internet access in cable modems, our family of F connectors offer a high performance solution.

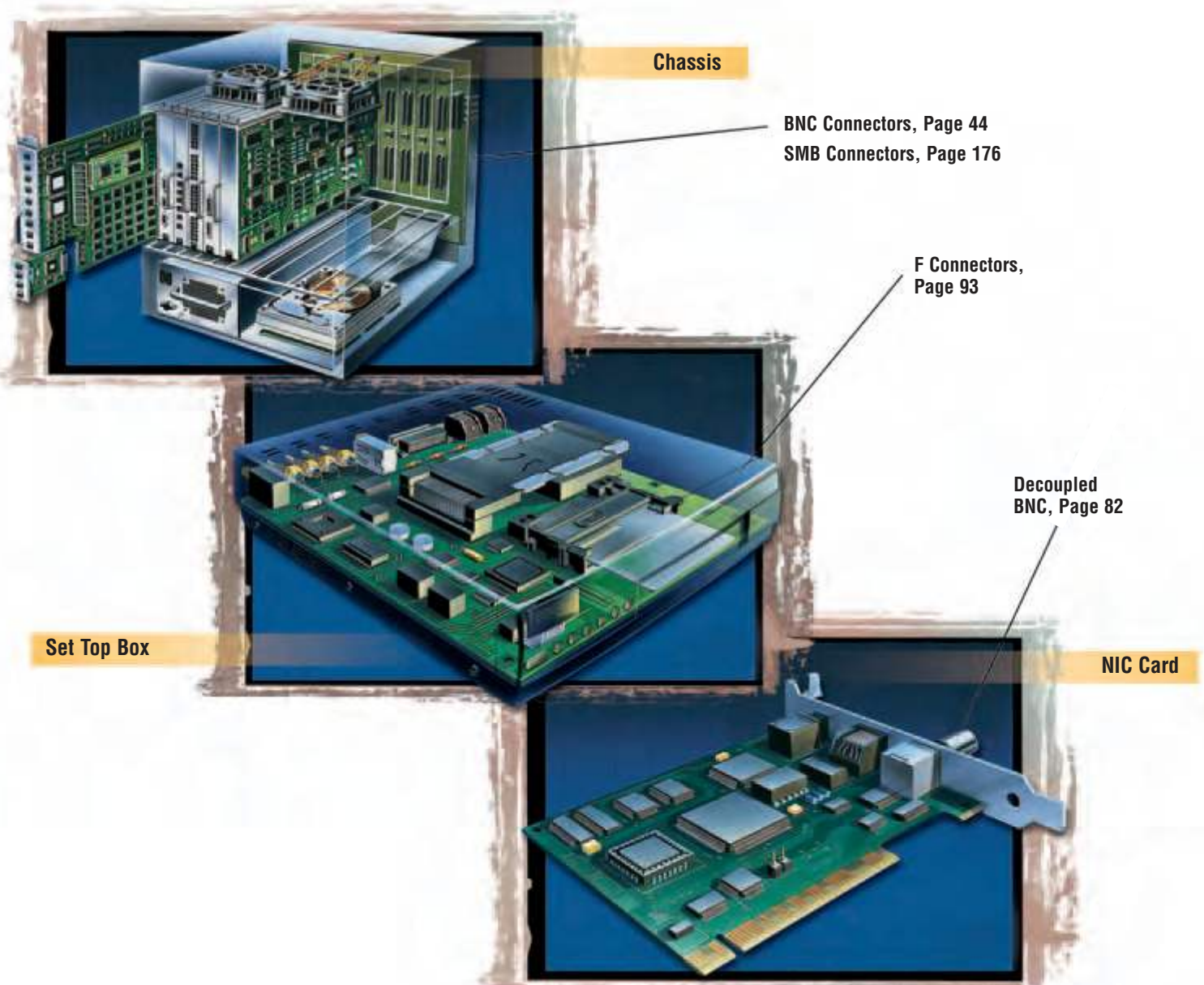

**Chassis**

**BNC Connectors, Page 44**  
**SMB Connectors, Page 176**

**F Connectors, Page 93**

**Decoupled BNC, Page 82**

**Set Top Box**

**NIC Card**

## Non-RoHS to RoHS Compliant Part Number Cross Reference

Non-RoHS Part No.	RoHS Compliant Part No.	Non-RoHS Part No.	RoHS Compliant Part No.	Non-RoHS Part No.	RoHS Compliant Part No.	Non-RoHS Part No.	RoHS Compliant Part No.
13126-1	Exempt	222092-1	5222092-1	225669-2	5225669-2	227764-2	5227764-2
13127-1	Exempt	222092-3	5222092-3	225699-1	5225699-1	227818-1	5227818-1
59980-1	Exempt	222093-1	5222093-1	225886-1	5225886-1	227820-1	5227820-1
69477-1	Exempt	222117-1	5222117-1	225886-4	5225886-4	227839-1	5227839-1
69710-1	Exempt	222132-1	5222132-1	225886-5	5225886-5	228217-1	5228217-1
148385-1	5148385-1	222165-2	5222165-2	225886-7	5225886-7	228226-1	5228226-1
148386-1	5148386-1	222420-1	5222420-1	225974-1	5225974-1	228226-3	5228226-3
189721-1	Exempt	222462-1	5222462-1	225974-2	5225974-2	228435-1	5228435-1
220015-1	Exempt	222506-1	5222506-1	225974-5	5225974-5	228596-1	5228596-1
220220-2	Exempt	222506-5	5222506-5	226978-1	5226978-1	228596-2	5228596-2
220221-2	Exempt	222506-6	5222506-6	226978-3	5226978-3	228596-3	5228596-3
220222-1	Exempt	225089-4	5225089-4	226990-1	5226990-1	228596-4	5228596-4
220224-2	Exempt	225092-8	5225092-8	226990-3	5226990-3	228596-5	5228596-5
221111-1	5221111-1	225349-9	5225349-9	226990-6	5226990-6	228618-1	5228618-1
221123-2	5221123-2	225361-2	5225361-2	226993-1	5226993-1	228618-2	5228618-2
221128-1	5221128-1	225361-4	5225361-4	226993-2	5226993-2	228618-3	5228618-3
1-221128-0	1-5221128-0	1-225361-2	1-5225661-2	226993-3	5226993-3	228618-4	5228618-4
1-221128-1	1-5221128-1	225363-1	5225363-1	226993-6	5226993-6	228618-5	5228618-5
1-221128-7	1-5221128-7	225392-2	5225392-2	227079-5	5227079-5	228686-1	5228686-1
2-221128-1	2-5221128-1	225395-1	5225395-1	227079-6	5227079-6	228979-5	5228979-5
2-221128-3	2-5221128-3	225395-2	5225395-2	227079-7	5227079-7	228979-6	5228979-6
2-221128-7	2-5221128-7	225395-3	5225395-3	1-227079-1	1-5227079-1	228979-7	5228979-7
3-221128-1	3-5221128-1	225395-6	5225395-6	1-227079-6	1-5227079-6	228980-5	5228980-5
221162-1	5221162-1	225395-7	5225395-7	1-227079-9	1-5227079-9	228980-6	5228980-6
221185-1	5221185-1	225395-8	5225395-8	2-227079-2	2-5227079-2	228980-7	5228980-7
221185-2	5221185-2	1-225395-0	1-5225395-0	4-227079-3	4-5227079-3	307581-1	Exempt
221185-3	5221185-3	2-225395-0	2-5225395-0	5-227079-3	5-5227079-3	311386-1	Exempt
221185-5	5221185-5	4-225395-1	4-5225395-1	6-227079-1	6-5227079-1	311386-2	Exempt
221185-7	5221185-7	4-225395-2	4-5225395-2	6-227079-7	6-5227079-7	311386-3	Exempt
221185-8	5221185-8	225396-1	5225396-1	6-227079-8	6-5227079-8	311392-1	Exempt
221185-9	5221185-9	225396-2	5225396-2	8-227079-2	8-5227079-2	311395-1	Exempt
1-221185-0	1-5221185-0	225396-7	5225396-7	1-227086-0	1-5227086-0	311396-1	Exempt
1-221185-8	1-5221185-8	225397-1	5225397-1	227161-1	5227161-1	312067-1	Exempt
2-221185-9	2-5221185-9	225397-2	5225397-2	227161-2	5227161-2	312253-1	Exempt
3-221185-1	3-5221185-1	225397-7	5225397-7	227161-3	5227161-3	312253-2	Exempt
221198-1	5221198-1	225398-1	5225398-1	227161-6	5227161-6	312317-1	Exempt
221199-1	5221199-1	225398-3	5225398-3	227161-7	5227161-7	2-329444-1	2-5329444-1
221199-2	5221199-2	225398-6	5225398-6	227161-9	5227161-9	2-329444-2	2-5329444-2
221199-5	5221199-5	225398-7	5225398-7	227169-5	5227169-5	2-329445-1	2-5329445-1
221221-1	5221221-1	225398-8	5225398-8	227169-7	5227169-7	2-329446-1	2-5329446-1
221221-2	5221221-2	1-225398-5	1-5225398-5	227169-8	5227169-8	2-329452-2	2-5329452-2
221221-5	5221221-5	225554-6	5225554-6	227222-1	5227222-1	2-329456-1	2-5329456-1
221221-7	5221221-7	1-225554-1	1-5225554-1	227222-2	5227222-2	2-329458-1	2-5329458-1
221244-1	5221244-1	225555-2	5225555-2	227222-3	5227222-3	329517	5329517
221325-1	5221325-1	225555-6	5225555-6	227222-6	5227222-6	2-330061-1	2-5330061-1
221336-3	5221336-3	225555-7	5225555-7	227426-1	5227426-1	2-330062-1	2-5330062-1
221336-4	5221336-4	225555-8	5225555-8	227661-1	5227661-1	2-330063-1	2-5330063-1
221402-2	5221402-2	225557-6	5225557-6	227671-1	5227671-1	2-330358-2	2-5330358-2
221402-4	5221402-4	225559-2	5225559-2	227673-1	5227673-1	330876	5330876
221506-2	5221506-2	225559-8	5225559-8	227676-1	5227676-1	330878	5330878
221506-3	5221506-3	225661-1	5225661-1	227677-1	5227677-1	331175	5331175
221506-5	5221506-5	225661-2	5225661-2	227699-1	5227699-1	331178	5331178
221629-1	5221629-1	1-225661-3	1-5225661-3	227699-2	5227699-2	331182	5331182
221629-2	5221629-2	1-225661-6	1-5225661-6	227699-3	5227699-3	331238	5331238
221629-4	5221629-4	225662-2	5225662-2	227716-3	5227716-3	332215	5332215
221629-5	5221629-5	1-225662-8	1-5225662-8	227726-1	5227726-1	332225-3	5332225-3
221629-6	5221629-6	225664-1	5225664-1	227726-2	5227726-2	332225-5	5332225-5
1-221629-6	1-5221629-6	225664-2	5225664-2	227726-3	5227726-3	332225-6	5332225-6
221980-1	5221980-1	1-225664-2	1-5225664-2	227755-1	5227755-1	332225	5332225
221981-2	5221981-2	1-225667-6	1-5225667-6	227755-2	5227755-2	332342	5332342
222006-1	5222006-1	225669-1	5225669-1	227755-3	5227755-3	413194-1	5413194-1

**Non-RoHS to RoHS Compliant Part Number Cross Reference (Continued)**

Non-RoHS Part No.	RoHS Compliant Part No.	Non-RoHS Part No.	RoHS Compliant Part No.	Non-RoHS Part No.	RoHS Compliant Part No.	Non-RoHS Part No.	RoHS Compliant Part No.
413194-2	5413194-2	413969-2	5413969-2	415189-1	5415189-1	1055441-1	Exempt
413311-1	5414311-1	413986-1	5413986-1	415205-1	5415205-1	1055442-1	Exempt
413364-2	5413364-2	414088-1	5414088-1	415214-1	5415214-1	1055443-1	Exempt
413366-2	5413366-2	414094-2	5414094-2	415216-1	5415216-1	1055444-1	Exempt
413476-2	5413476-2	414105-1	5414105-1	415218-5	5415218-5	1055445-1	Exempt
413506-1	5413506-1	414160-5	5414160-5	415226-1	5415226-1	1055446-1	Exempt
413515-2	5413515-2	414168-1	5414168-1	415232-4	5415232-4	1055447-1	Exempt
413515-3	5413515-3	414168-3	5414168-3	415232-7	5415232-7	1055448-1	Exempt
413515-7	5413515-7	414168-4	5414168-4	415242-2	5415242-2	1055449-1	Exempt
413515-8	5413515-8	414168-5	5414168-5	415242-6	5415242-6	1055450-1	Exempt
413515-9	5413515-9	414168-6	5414168-6	415248-1	5415248-1	1055451-1	Exempt
413524-2	5413524-2	414170-1	5414170-1	415248-7	5415248-7	1055454-1	Exempt
413524-5	5413524-5	414170-2	5414170-2	415252-1	5415252-1	1055474-1	Exempt
413557-1	5413557-1	414171-3	5414171-3	415252-2	5415252-2	1055475-1	Exempt
413557-2	5413557-2	414173-3	5414173-3	415252-3	5415252-3	1055476-1	Exempt
413558-1	5413558-1	414194-1	5414194-1	415252-4	5415252-4	1055477-1	Exempt
413558-2	5413558-2	414215-1	5414215-1	415255-1	5415255-1	1055500-1	Exempt
413558-3	5413558-3	414217-1	5414217-1	415255-2	5415255-2	1055831-1	Exempt
413558-5	5413558-5	414265-3	5414265-3	415255-3	5415255-3	1055832-1	Exempt
413588-2	5413588-2	414284-2	5414284-2	415255-4	5415255-4	1055833-1	Exempt
413588-4	5413588-4	414305-1	5414305-1	415276-2	5415276-2	1055834-1	Exempt
413588-8	5413588-8	414337-1	5414337-1	415302-1	5415302-1	1055836-1	Exempt
413588-9	5413588-9	414338-1	5414338-1	415302-2	5415302-2	1055837-1	Exempt
1-413588-0	1-5413588-0	414352-1	5414352-1	415322-2	5415322-2	1055838-1	Exempt
413589-1	5413589-1	414363-3	5414363-3	415332-1	5415332-1	1055839-1	Exempt
413589-2	5413589-2	414363-4	5414363-4	415379-1	5415379-1	1055840-1	Exempt
413589-3	5413589-3	414363-5	5414363-5	415381-1	5415381-1	1055841-1	Exempt
413589-5	5413589-5	414363-8	5414363-8	415406-2	5415406-2	1055842-1	Exempt
413589-7	5413589-7	414367-2	5414367-2	415417-1	5415417-1	1055843-1	Exempt
413589-8	5413589-8	414373-1	5414373-1	415419-1	5415419-1	1057088-1	6057088-1
413589-9	5413589-9	414394-1	5414394-1	415485-1	5415485-1	1057094-1	6057094-1
1-413589-0	1-5413589-0	414409-1	5414409-1	415485-2	5415485-2	1057116-1	6057116-1
1-413589-1	1-5413589-1	414414-1	5414414-1	415485-3	5415485-3	1057159-1	6057159-1
1-413589-6	1-5413589-6	414459-1	5414459-1	415487-1	5415487-1	1057165-1	6057165-1
413590-3	5413590-3	414460-1	5414460-1	415487-2	5415487-2	1057176-1	6057176-1
413590-4	5413590-4	414493-4	5414493-4	415487-3	5415487-3	1059632-1	6059632-1
413590-8	5413590-8	414553-1	5414553-1	415520-1	5415520-1	1059665-1	6059665-1
413591-1	5413591-1	414651-3	5414651-3	415569-2	5415569-2	1061002-1	6061002-1
413592-2	5413592-2	414666-1	5414666-1	415632-1	5415632-1	1061035-1	6061035-1
413592-6	5413592-6	414758-1	5414758-1	415632-2	5415632-2	1061092-1	6061092-1
413592-9	5413592-9	414758-2	5414758-2	415633-1	5415633-1	1061094-1	6061094-1
1-413592-1	1-5413592-1	414758-3	5414758-3	415634-1	5415634-1	1213890-1	Exempt
413631-1	5413631-1	414907-1	5414907-1	415634-2	5415634-2	1274020-1	6274020-1
413631-2	5413631-2	414946-2	5414946-2	415683-1	5415683-1	1274032-1	6274032-1
413631-3	5413631-3	414946-3	5414946-3	415712-1	5415712-1	1274045-1	6274045-1
413760-1	5413760-1	414946-5	5414946-5	415779-1	5415779-1	1274072-1	6274072-1
413760-3	5413760-3	414946-6	5414946-6	415832-1	5415832-1	1274084-1	6274084-1
413760-8	5413760-8	415006-1	5415006-1	447648-3	5447648-3	1274086-1	6274086-1
413760-9	5413760-9	415006-2	5415006-2	448103-2	5448103-2	1274096-1	6274096-1
413771-1	5413771-1	415020-1	5415020-1	603995-1	Exempt	1274124-2	6274124-2
413771-3	5413771-3	415024-1	5415024-1	603995-2	Exempt	1274127-1	6274127-1
413779-3	5413779-3	415024-3	5415024-3	603995-3	Exempt	1274220-1	6274220-1
2-413779-4	2-5413779-4	415025-1	5415025-1	603995-5	Exempt	1274291-1	6274291-1
413879-1	5413879-1	415025-2	5415025-2	603995-6	Exempt	1274291-2	6274291-2
413879-2	5413879-2	415046-1	5415046-1	856402-1	Exempt	1274314-1	6274314-1
413933-1	5413933-1	415085-1	5415085-1	887000-1	5887000-1	1274315-1	6274315-1
413959-1	5413959-1	415103-1	5415103-1	887046-1	5887046-1	1274359-1	6274359-1
413959-3	5413959-3	415103-2	5415103-2	887078-1	5887078-1	1274360-1	6274360-1
413959-4	5413959-4	415105-1	5415105-1	887089-1	5887089-1	1274425-2	6274425-2
413959-5	5413959-5	415105-2	5415105-2	1055439-1	Exempt	1274431-1	6274431-1
413959-6	5413959-6	415187-1	5415187-1	1055440-1	Exempt	1274532-1	6274532-1

**Non-RoHS to RoHS Compliant Part Number Cross Reference (Continued)**

Non-RoHS Part No.	RoHS Compliant Part No.	Non-RoHS Part No.	RoHS Compliant Part No.	Non-RoHS Part No.	RoHS Compliant Part No.	Non-RoHS Part No.	RoHS Compliant Part No.
1311164-1	Exempt	1361137-1	6361137-1	1-1393524-1	Exempt	1393696-2	6-1393696-2
1312079-1	6312079-1	1361138-1	1361138-1	2-1393524-4	Exempt	1393696-7	6-1393696-7
1312113-1	6312113-1	1361139-1	6361139-1	2-1393524-6	Exempt	1402314-1	1402314-1
1312121-1	6312121-1	1362765-1	6362765-1	2-1393524-7	Exempt	1408026-1	6408026-1
1312123-1	6312123-1	1363524-1	6363524-1	1393665-1	6-1393665-1	1408027-1	6408027-1
1312124-1	6312124-1	1363525-1	6363525-1	1-1393665-4	—	1408028-1	6408028-1
1312137-1	1312137-1	1363526-1	6363526-1	1-1393665-5	—	1408030-1	6408030-1
1312138-1	6312138-1	1363527-1	6363527-1	1-1393665-6	—	1408032-1	6408032-1
1312139-1	6312139-1	1393488-3	Exempt	1-1393665-7	—	1408033-1	6408033-1
1328873-1	6328873-1	1393488-4	Exempt	2-1393670-1	—	1408036-1	6408036-1
1329818-1	6329818-1	1393524-1	Exempt	2-1393670-2	—	1408037-1	6408037-1
1329819-1	1329819-1	1393524-4	Exempt	2-1393670-3	—	1408038-1	6408038-1
1331959-1	6331959-1	1393524-5	Exempt	2-1393670-4	—	1725637-1	Exempt

## M/A-COM to Tyco Electronics Part Number Cross Reference

M/A-COM Part No.	Tyco Electronics Part No.	M/A-COM Part No.	Tyco Electronics Part No.	M/A-COM Part No.	Tyco Electronics Part No.	M/A-COM Part No.	Tyco Electronics Part No.
127669-92	1311164-1	2052 5674 02	1052902-1	2598 5208 54	1055843-1	3104 7985 00	1057679-1
127893-98	1402314-1	2054 1201 02	1052978-1	2598 5342 54	1221286-1	3106 7941 00	1057697-1
2001 5003 02	1050525-1	2054 1231 02	1052982-1	2598 5438 54	1088313-1	3106 7985 00	1057699-1
2001 5031 02	1050542-1	2054 1241 02	1052986-1	2831 7316 02	1056436-1	3152 0000 10	1057775-1
2001 5032 02	1050548-1	2056 5006 02	1053092-1	2831 7341 02	1056438-1	3152 1201 10	1057780-1
2001 5385 02	1050598-1	2058 5029 02	1053222-1	2831 7388 02	1056443-1	3180 2242 00	1057841-1
2001 5395 02	1050602-1	2062 0000 00	1053354-1	2834 7316 02	1056445-1	3180 2320 00	1057843-1
2001 5443 02	1050611-1	2064 0000 00	1053378-1	2834 7341 02	1056447-1	3180 2320 00	1057845-1
2001 7188 02	1050721-1	2080 0000 00	1053488-1	2834 7358 02	1056450-1	3182 2240 00	1057853-1
2001 7641 02	1050740-1	2081 0000 02	1053635-1	2834 7388 02	1056452-1	3182 2243 00	1057857-1
2001 7941 02	1050757-1	2081 2301 00	1053646-1	2837 7316 02	1056456-1	3184 2240 00	1057908-1
2001 7985 02	1050770-1	2082 2249 02	1053780-1	2837 7388 02	1056462-1	3280 2224 00	1058056-1
2002 5015 00	1050854-1	2082 2700 00	1053788-1	2902 7947 62	1056526-1	3280 2240 00	1058058-1
2002 5016 00	1050859-1	2082 5133 02	1054426-1	2902 7985 62	1056527-1	3281 2223 00	1058066-1
2002 7188 02	1050903-1	2084 0000 02	1054869-1	2908 7947 62	1056553-1	3282 2223 00	1058077-1
2004 7188 02	1050996-1	2086 0000 02	1055018-1	2908 7985 62	1056554-1	3282 2240 00	1058081-1
2004 7641 02	1051005-1	2087 1230 02	1055047-1	2965 5006 62	1061692-1	3282 2241 00	1058083-1
2004 7685 02	1051007-1	2088 0000 02	1055065-1	2980 0000 62	1056700-1	3284 2240 00	1058117-1
2006 5010 00	1051046-1	2098 5206 54	1055439-1	2980 2240 00	1056702-1	3680 2240 00	1058651-1
2006 5013 00	1051052-1	2098 5207 54	1055440-1	2981 2241 00	1056706-1	3680 2242 00	1058653-1
2006 7941 00	1051081-1	2098 5208 54	1055441-1	2982 2240 00	1056707-1	3682 2241 00	1058664-1
2006 7985 00	1051085-1	2098 5209 02	1055442-1	2982 2241 00	1056708-1	3682 2242 00	1058666-1
2007 7188 02	1051140-1	2098 5210 02	1055443-1	2998 5001 02	1056721-1	3684 2240 00	1058675-1
2007 7641 02	1051145-1	2098 5211 02	1055444-1	2998 5002 02	1056722-1	4503 7685 02	1059399-1
2007 7685 02	1051147-1	2098 5212 02	1055445-1	2998 5003 02	1056724-1	4503 7941 00	1059402-1
2007 7941 02	1051151-1	2098 5213 02	1055446-1	2998 5022 94	1056728-1	4503 7985 00	1059404-1
2007 7985 02	1051157-1	2098 5214 02	1055447-1	2998 5028 02	1056729-1	4504 7641 02	1059408-1
2031 5002 00	1051638-1	2098 5215 02	1055448-1	2998 5030 02	1056731-1	4504 7941 00	1059410-1
2031 5003 02	1051644-1	2098 5216 54	1055449-1	2998 5035 02	1056736-1	4504 7985 00	1059412-1
2032 5002 00	1051852-1	2098 5217 54	1055450-1	2998 5043 02	1056743-1	4506 7641 02	1059451-1
2032 5003 02	1051855-1	2098 5218 02	1055451-1	2998 5044 02	1056744-1	4506 7685 02	1059452-1
2032 5007 00	1051861-1	2098 5221 10	1055454-1	2998 5045 02	1056745-1	4506 7941 02	1059453-1
2032 5021 02	1051867-1	2098 5279 10	1055474-1	2998 5054 94	1056750-1	4506 7985 02	1059456-1
2032 5026 02	1051869-1	2098 5281 02	1055475-1	2998 5055 94	1056751-1	4510 7941 00	1059465-1
2034 5008 00	1051942-1	2098 5282 02	1055476-1	2998 5056 94	1056752-1	4510 7985 00	1059467-1
2037 5005 02	1052063-1	2098 5283 02	1055477-1	3001 7941 00	6057088-1	4522 7941 02	1059505-1
2037 5006 02	1052067-1	2098 5516 02	1055500-1	3001 7985 00	6057094-1	4522 7985 02	1059506-1
2037 5007 02	1052072-1	2204 7941 09	1082029-1	3002 7941 00	6057116-1	4533 7388 02	1059523-1
2037 5008 02	1052076-1	2207 7985 09	1088312-1	3004 7941 00	6057159-1	4534 7341 02	1059525-1
2037 5100 02	1052098-1	2231 7388 36	1082034-1	3004 7985 00	6057165-1	4536 5014 02	1058572-1
2051 0000 02	1052324-1	2318 0000 54	1085456-1	3006 7941 00	6057176-1	4536 7341 02	1059540-1
2051 1352 02	1052349-1	2367 0000 54	1251802-1	3051 0000 10	1057275-1	4536 7388 02	1059541-1
2051 1618 02	1052360-1	2367 5001 54	1083946-1	3051 1200 10	1057277-1	4540 7388 02	1059551-1
2052 0000 02	1052422-1	2367 5002 54	1055689-1	3051 1201 10	1057279-1	4551 1201 02	1059563-1
2052 1200 02	1052518-1	2380 2240 00	1055694-1	3052 0000 10	1057284-1	4551 1352 02	1059566-1
2052 1201 00	1052522-1	2381 2241 00	1055695-1	3052 1201 10	1057290-1	4551 3357 02	1059572-1
2052 1201 02	1052523-1	2382 2240 00	1055696-1	3080 2240 00	1057341-1	4552 1201 02	1059594-1
2052 1215 02	1052528-1	2382 2241 00	1055697-1	3080 2242 00	1057343-1	4552 1352 02	1059596-1
2052 1300 02	1052534-1	2399 5011 54	1086008-1	3081 2241 00	1057367-1	4557 5009 02	1059617-1
2052 1350 02	1052544-1	2399 5012 54	1086009-1	3082 0000 00	1057374-1	4557 5119 02	6059632-1
2052 1352 02	1052552-1	2598 5196 54	1055831-1	3082 2240 00	1057377-1	4557 5329 02	1059637-1
2052 1612 02	1052563-1	2598 5197 54	1055832-1	3082 2241 00	1057381-1	4557 5368 02	1059651-1
2052 1658 02	1052577-1	2598 5198 54	1055833-1	3082 2243 00	1057385-1	4558 1154 02	1059654-1
2052 3354 02	1052628-1	2598 5199 54	1055834-1	3082 2310 00	1057387-1	4558 5009 02	1059657-1
2052 3356 02	1052634-1	2598 5201 54	1055836-1	3082 2311 00	1057388-1	4558 5119 02	6059665-1
2052 3358 02	1052643-1	2598 5202 54	1055837-1	3082 2320 00	1057390-1	4558 5329 02	1059671-1
2052 3359 02	1052646-1	2598 5203 54	1055838-1	3082 2321 00	1057392-1	4562 0000 00	1059681-1
2052 3363 02	1052652-1	2598 5204 54	1055839-1	3084 2240 00	1057463-1	4563 0000 00	1059684-1
2052 3500 02	1052684-1	2598 5205 54	1055840-1	3101 7941 00	1057631-1	4563 5004 00	1253111-1
2052 3502 02	1052689-1	2598 5206 54	1055841-1	3101 7985 00	1057635-1	4565 0000 00	1059691-1
2052 5636 02	1052898-1	2598 5207 54	1055842-1	3104 7941 00	1057676-1	4580 2240 02	1059707-1



**M/A-COM to Tyco Electronics Part Number Cross Reference (Continued)**

M/A-COM Part No.	Tyco Electronics Part No.	M/A-COM Part No.	Tyco Electronics Part No.	M/A-COM Part No.	Tyco Electronics Part No.	M/A-COM Part No.	Tyco Electronics Part No.
4581 2241 02	1059711-1	5837 5025 10	1330723-1	9960 3100 24	1082845-1	B67B44TA25X	1313508-1
4581 2700 00	1059713-1	5837 5030 10	1329293-1	9960 4100 01	1064543-1	B67E64T022X	1408041-1
4582 2240 02	1059716-1	5837 5031 09	1363301-2	9960 4100 02	1064544-1	B67H16T493X	1313511-1
4582 2241 02	1059718-1	5837 5031 10	1363301-1	9960 4100 04	1064546-1	B67H49T022X	1311115-1
4582 2700 00	1059720-1	5858 0000 09	1060959-1	9960 4100 07	1064549-1	B67H64T022X	1327083-1
4583 2240 02	1059724-1	5858 0000 10	1060960-1	9960 4100 08	1064550-1	B67H64T062X	1311117-1
4584 2240 02	1059729-1	5862 5002 09	1060984-1	9960 4200 01	1064552-1	B67H66T117X	1311700-1
4584 2242 02	1059731-1	5862 5002 10	1060985-1	9960 4200 02	1064553-1	B67H64T280X	1313883-1
4584 2244 02	1059733-1	5862 5003 09	1330126-1	9960 4200 04	1064555-1	B67H64T437X	1311118-1
4585 2240 02	1059756-1	5862 5003 10	1060989-1	9960 4200 07	1064558-1	B67H64TA25X	1313887-1
4585 2241 02	1059758-1	5862 5004 09	1060995-1	9960 4200 08	1064559-1	B67H66T022X	1311120-1
4703 7985 00	1059857-1	5862 5004 10	1060996-1	9960 4305 01	1064560-1	B67H66T062X	1311701-1
4706 7985 02	1059868-1	5862 5007 13	6061002-1	9960 4305 02	1064561-1	B67H66T437X	1311122-1
4710 7985 00	1059874-1	5862 5018 13	1061007-1	9960 4305 04	1064563-1	B67H74T463X	1314422-1
4733 7316 02	1059884-1	5863 0000 09	1085221-1	9960 4305 07	1064566-1	B67N08T999X	1311125-1
4733 7388 02	1059886-1	5863 0000 10	1061015-1	9960 4305 08	1064567-1	B67N12T999X	1314103-1
4736 5001 02	1059887-1	5864 5001 09	1061022-1	9980 4100 01	1329174-1	B67N25T999X	1314102-1
4736 7316 02	1059888-1	5864 5001 10	1061023-1	9980 4100 02	1329175-1	B67P34G999X	1313364-1
4740 7388 00	1059889-1	5864 5002 09	1061026-1	9980 4100 04	1408050-4	B67R53G999X	1311127-1
4751 3355 02	1059894-1	5864 5002 10	1061027-1	9980 4100 05	1255378-4	B67Z50T999X	6-1311703-1
4757 1154 02	1059901-1	5864 5003 09	1061029-1	9980 4100 07	1408051-4	C65E06G022X	1311638-1
4757 3204 00	1059902-1	5864 5003 10	1061030-1	9980 4100 08	1330401-4	D75A02B001X	6331959-1
4757 5006 02	1059903-1	5864 5008 13	6061035-1	9980 4200 01	1329174-2	D75A02B004X	6362765-1
4757 5014 00	1059905-1	5880 2240 00	1061070-1	9980 4200 02	1329175-2	D75B01B470X	6328873-1
4763 0000 00	1059919-1	5881 2241 00	1061071-1	9980 4200 04	1408050-5	D75B02B010X	6408028-1
5001 5015 09	1060163-1	5882 2240 00	1061072-1	9980 4200 05	1255378-5	D75B03B001X	6408030-1
5007 5008 09	1060183-1	5882 2241 00	1061073-1	9980 4200 07	1408051-5	D75B03B004X	6312113-1
5031 5007 09	1060220-1	5899 5004 54	6061092-1	9980 4200 08	1330401-5	D75B04B004X	6408027-1
5031 5014 09	1060221-1	5899 5009 54	6061094-1	9980 4305 01	1310432-1	D75B04B010X	6408026-1
5062 5003 09	1060256-1	7081 2301 00	1061738-1	9980 4305 02	1329175-3	D75B05B004X	6408038-1
5064 5003 09	1060259-1	7081 2311 00	1061739-1	9980 4305 04	1408050-6	D75G03B001R	6408032-1
5134 5016 10	1254781-1	7081 5008 00	1061742-1	9980 4305 05	1255378-6	D75G03B004R	6408033-1
5180 2240 00	1060487-1	7081 5009 00	1061744-1	9980 4305 07	1408051-6	D75G07B060R	6363524-1
5181 2241 00	1060494-1	7082 2242 00	1061750-1	9980 4305 08	1330401-6	D75G08B001R	6363525-1
5182 2240 00	1060498-1	7082 2243 00	1061751-1	A55P22E999X	1311206-1	D75G08B004R	6363526-1
5182 2241 00	1060500-1	7082 2300 00	1061752-1	A55P23E999X	1313453-1	D75G09B010R	6363527-1
5801 7947 09	1060772-2	7082 2310 00	1061753-1	A55X01B999X	6312079-1	D75G10B004R	6408036-1
5801 7985 09	1060772-1	7082 5004 00	1061757-1	A57R03G999X	1311209-1	D75R02B999X	6408037-1
5802 7947 09	1060774-2	7082 5005 00	1061758-1	B67A54T022X	1311097-1	D75X06B999X	6312121-1
5802 7985 09	1060774-1	9631 7179 10	1362990-1	B67A54T117X	1311098-1	D75X12E470X	6312123-1
5807 7985 09	1060787-1	9637 7179 10	1362991-1	B67A64T022X	1311099-1	D75X14B999X	6312124-1
5818 5002 09	1060811-2	9662 5000 10	1361169-1	B67A64T062X	1311100-1	D75X15B999X	6361137-1
5818 5002 10	1060811-1	9664 0000 10	1363106-1	B67A64T280X	1311696-1	N15X09E470X	1312137-1
5818 5003 10	1060813-1	9960 1100 24	1064524-1	B67A64T437X	1311102-1	N15X10B999X	6312138-1
5831 5002 10	1060869-1	9960 1200 24	1064530-1	B67A64TA25X	1313507-1	N15X12E470X	6329818-1
5831 5003 09	1060871-1	9960 1305 24	1064533-1	B67B42T022X	1311103-1	N15X14E010X	6312139-1
5831 5003 10	1060872-1	9960 2100 24	1064535-1	B67B42T437X	1311104-1	N15X16E999X	1361138-1
5831 7316 09	1060875-2	9960 2200 24	1064538-1	B67B44T022X	1311106-1	N15X17E999X	6361139-1
5831 7316 10	1060875-1	9960 2305 24	1064540-1	B67B44T062X	1311698-1	N15X18E010X	1329819-1
5834 7388 10	1060883-1	9960 2510 24	1064542-1	B67B44T437X	1311111-1	T35E60E010X	1312569-1

## Part Number Index

**Note:** This index lists all cataloged parts by base no. only. Complete part nos. (with prefixes and/or suffixes) are shown on the page(s) indicated.

Part No.	Page	Part No.	Page	Part No.	Page		
50084	246	413985	178	619229	206	1052689	120
50095	246	413990	180	619231	233	1052898	118
50105	246	413996	181	619238	206	1052902	119
50107	246	414002	178	619271	261	1052978	117
51563	247, 248	414026	181	887098	94	1052982	117
51565	248	414171	35	1050525	110	1052986	117
51692	21	414396	43	1050542	110	1053092	115
51751	194	414612	180	1050548	110	1053222	117
201097	245	414766	94	1050598	112	1053354	121
201098	245	414895	182	1050602	112	1053378	121
201143	245	414946	178	1050611	112	1053488	122
201144	245	414948	179	1050721	105	1053635	122
201145	245	414963	181	1050740	112	1053646	256
201146	245	414969	182	1050757	110	1053780	123
221108	58, 72, 73	415001	182	1050770	110	1053788	259
221500	41	415232	21	1050854	110	1054426	123
221509	42	415327	99	1050859	110	1054869	123
221539	94	415340	181	1050903	105	1055018	122
221540	94	415377	185	1050996	106	1055047	123
221543	63	415380	181	1051005	113	1055065	122
221551	64	415381	181	1051007	113	1055689	214
221586	63	415490	185	1051046	111	1055694	217, 255
221789	121	415500	184	1051052	111	1055695	217, 253
221790	121	415504	185	1051081	111	1055696	217, 258
221951	55, 56	415523	99	1051085	111	1055697	217, 259
221988	63	415567	76	1051140	106	1056436	106
222163	61, 74	415672	181	1051145	113	1056438	106
222428	52	415774	180	1051147	113	1056443	106
225014	22	415796	64	1051151	112	1056445	107
225088	248	619028	230, 235	1051157	112	1056447	107
225093	22	619041	230	1051638	104	1056450	107
225094	23	619052	235	1051644	104	1056452	107
225348	38	619053	236	1051852	104	1056456	108
225389	22	619061	230, 231	1051855	107	1056462	108
225551	35	619062	230, 231	1051861	104	1056526	154
225668	23	619068	235	1051867	107	1056527	154
225886	49	619072	230, 231	1051869	107	1056553	154
226023	247	619075	233	1051942	104	1056554	154
226060	247	619076	235	1052063	105	1056700	152, 154
226537	248	619078	230, 235	1052067	105	1056702	255
227223	55, 56	619085	131	1052072	108	1056706	253
227945	25	619106	136	1052076	108	1056707	258
228179	33	619107	133	1052098	108	1056708	259
228215	182	619115	115	1052324	114	1056721	152, 155
228216	182	619127	204	1052349	116	1056722	155
228502	37	619133	232	1052360	118	1056724	155
228553	179	619134	204	1052422	114	1056728	156
228658	23	619135	204	1052518	116	1056729	155
282938	97	619137	235	1052522	116	1056731	155
329631	57, 58, 59, 73, 91	619196	234	1052523	116	1056736	155
329632	57, 58, 59, 73, 91	619201	233	1052528	119	1056743	155
330022	65	619210	236	1052534	114	1056744	155
330024	64	619211	234	1052544	114	1056745	155
330620	54	619213	234	1052552	116	1056750	156
332056	248	619214	236	1052563	118	1056751	156
332057	248	619215	127	1052577	119	1056752	156
413453	65	619219	261	1052628	120	1057275	24
		619220	136	1052634	120	1057277	24
		619223	131	1052643	120	1057279	24
		619224	131	1052646	120	1057284	24
		619226	135	1052652	120	1057290	24
		619228	135	1052684	120	1057341	254

**Part Number Index (Continued)**

Part No.	Page	Part No.	Page	Part No.	Page	Part No.	Page
1057343	254	1059617	165	1061007	201	1274330	181
1057367	253	1059637	167	1061015	200	1274449	133
1057374	25	1059651	165	1061022	201	1274513	145
1057377	258	1059654	165	1061023	201	1274520	133
1057381	257	1059657	165	1061026	201	1274544	134
1057385	257	1059671	168	1061027	201	1274563	80
1057387	258	1059681	166	1061029	201	1274566	80
1057388	257	1059684	166	1061030	201	1274568	80
1057390	257	1059691	166	1061070	254	1274571	81
1057392	257	1059707	255	1061071	253	1274572	81
1057463	254	1059711	253	1061072	258	1274584	81
1057631	33	1059713	256	1061073	256	1274594	133
1057635	33	1059716	259	1061692	156	1274662	28
1057676	37	1059718	257	1061738	256	1274663	81
1057679	37	1059720	257	1061739	256	1274668	57
1057697	38	1059724	255	1061742	256	1274684	81
1057699	38	1059729	255	1061744	256	1274688	27
1057775	41	1059731	255	1061750	259	1274689	27
1057780	41	1059733	255	1061751	256	1274694	109
1057841	254	1059756	259	1061752	257	1274714	137
1057843	254	1059758	257	1061753	258	1274734	27
1057845	254	1059857	171	1061757	256	1274735	27
1057853	258	1059868	171	1061758	258	1274794	237
1057857	258	1059874	171	1064524	214	1274795	237
1057908	255	1059884	172	1064530	214	1274804	27
1058056	254	1059886	172	1064533	214	1274805	27
1058058	254	1059887	172	1064535	215	1274806	27
1058066	253	1059888	172	1064538	215	1274807	28
1058077	257	1059889	172	1064540	215	1274808	28
1058081	258	1059894	175	1064542	215	1274935	76
1058083	257	1059901	173	1064543	216	1310432	210
1058117	254	1059902	175	1064544	216	1311097	187
1058572	163	1059903	173	1064546	216	1311098	187
1058651	255	1059905	175	1064549	217	1311099	187
1058653	255	1059919	174	1064550	217	1311100	187
1058664	257	1060163	194	1064552	216	1311101	187
1058666	259	1060183	195	1064553	216	1311102	187
1058675	255	1060220	194	1064555	216	1311103	188
1059399	162	1060221	194	1064558	217	1311104	188
1059402	158, 160	1060256	195	1064559	217	1311106	188
1059404	158, 160	1060259	195	1064560	216	1311111	188
1059408	162	1060487	255	1064561	216	1311115	189
1059410	158, 160	1060494	253	1064563	216	1311117	190
1059412	158, 160	1060498	258	1064566	217	1311118	190
1059451	162	1060500	258	1064567	217	1311120	189
1059452	162	1060772	199	1082029	111	1311122	189
1059453	160	1060774	199	1082034	106	1311125	190
1059456	160	1060787	200	1082845	215	1311127	191
1059465	161	1060811	198	1083946	214	1311206	254
1059467	161	1060813	198	1085221	200	1311209	254
1059505	161	1060869	198	1085456	209	1311638	194
1059506	161	1060871	198	1086008	209	1311696	187
1059523	163	1060872	198	1086009	209	1311698	188
1059525	163	1060875	198	1088312	112	1311700	190
1059540	163	1060883	199	1088313	209	1311701	189
1059541	163	1060959	201	1221286	217	1311703	191
1059551	163	1060960	201	1251802	214	1312137	18
1059563	164	1060984	200	1253111	166	1312569	35
1059566	164	1060985	200	1255378	211	1313364	191
1059572	168	1060989	200	1274007	77	1313453	253
1059594	164	1060995	200	1274191	239	1313507	187
1059596	164	1060996	200	1274192	239	1313508	188

**Part Number Index (Continued)**

Part No.	Page	Part No.	Page	Part No.	Page	Part No.	Page
1313511	189	1408347	125	5222420	60	5329458	53
1313883	190	1408348	125	5222462	74	5329517	64
1313887	190	1408349	125	5222506	32	5330061	47
1314102	190	1408393	128, 253	5225089	24	5330062	51
1314103	190	1408496	220	5225092	21	5330063	53
1314422	190	1408541	109	5225349	34	5330358	48
1327083	190	1442004	206	5225361	21	5330876	47
1329174	210	1460010	131	5225363	23	5330878	49
1329175	210	1460052	10	5225392	21	5331175	50
1329293	198	1460055	25	5225395	47, 48, 49	5331178	50
1329819	18	1460060	134	5225396	51	5331182	50
1330126	200	1460118	25	5225397	52	5331238	36
1330401	211	1460128	144	5225398	53, 54	5332215	92
1330723	198	1460132	141	5225554	34	5332225	90
1361138	18	1460139	134	5225555	32	5332342	90
1361169	203	1460159	9	5225557	36	5413194	72
1362990	203	1460169	144	5225559	34	5413364	65
1362991	203	1460468	115	5225661	21	5413366	63
1363106	203	1460469	115	5225662	21	5413476	85
1363301	198	1460470	195	5225664	22	5413506	43
1392019	240	1460802	261	5225667	23	5413515	85
1392020	240	1460803	261	5225669	22	5413524	85
1393562	137, 147	1460815	135	5225699	21	5413557	65
1393662	241	1460817	135	5225886	49	5413558	75
1393665	148, 149, 150, 253, 256, 259	1460821	147, 148	5225974	50	5413588	68
1393668	240	1460823	146	5226978	59	5413589	66, 67
1393670	131, 132, 133, 134, 135, 136, 147, 253, 256, 259, 260	1484546	174	5226990	57	5413590	67, 70
1393672	141, 142, 143	1566230	224	5226993	58	5413591	42
1393680	140, 142, 143, 144	1658260	204	5227079	47, 48, 49	5413592	63
1393681	140, 141, 143, 145, 146, 150	1750107	225	5227086	21	5413631	62
1393682	140, 141, 142, 143, 144	1750108	225	5227161	57	5413760	69
1393696	250	1750109	225	5227169	55	5413771	53, 54
1393757	142, 145, 220	1750110	226	5227222	58	5413779	51
1402314	15	1775146	224	5227426	56	5413879	57
1407578	208	1775227	227, 260	5227661	57	5413933	40
1408041	188	1775228	227, 260	5227671	58	5413959	50
1408050	211	1775229	227, 259	5227673	58	5413969	60
1408051	211	1775230	227, 259	5227676	57	5413986	74
1408120	221	5148385	239	5227677	57	5414088	74
1408148	219	5148386	239	5227699	60	5414094	85
1408149	219	5221111	180	5227715	55	5414105	64
1408150	220	5221123	60	5227716	55	5414160	21
1408151	220	5221128	47, 48, 49, 55	5227726	56	5414168	36
1408152	221	5221162	243	5227754	55	5414170	179
1408312	219	5221185	66	5227755	55	5414171	35
1408313	219	5221198	91	5227764	40	5414173	34
1408314	219	5221199	69	5227818	39	5414194	56
1408332	127	5221221	70	5227820	39	5414215	85
1408333	126	5221244	71	5227839	39	5414217	71
1408336	126	5221325	41	5228217	179	5414265	50
1408337	127	5221336	75	5228226	64	5414284	85
1408338	126	5221402	68	5228435	181	5414305	60
1408339	126	5221506	42	5228596	242	5414311	63
1408340	128	5221629	65	5228618	242	5414337	181
1408341	128	5221980	242	5228686	91	5414338	181
1408342	128	5221981	242	5228979	51	5414352	85
1408343	128, 260	5222006	61	5228980	53, 54	5414363	178
1408346	125	5222092	72	5329444	48	5414367	88
		5222093	72	5329445	49	5414373	62
		5222117	76	5329446	47	5414394	74
		5222132	73	5329452	51	5414409	72
		5222165	64	5329456	54	5414414	64

**Part Number Index (Continued)**

Part No.	Page	Part No.	Page	Part No.	Page	Part No.	Page
5414459	72	5415255	22	6057116	22	6312079	14
5414460	60	5415276	96	6057159	23	6312113	9
5414493	87	5415302	95	6057165	23	6312121	15
5414553	87	5415322	97	6057176	23	6312123	19
5414651	86	5415332	98	6059632	167	6312124	19
5414666	64	5415379	181	6059665	167	6312138	15
5414758	87	5415406	98	6061002	202	6312139	19
5414907	72	5415417	72	6061035	202	6328873	10
5414946	178	5415419	72	6061092	202	6329818	17
5415006	179	5415484	184	6061094	202	6331959	9
5415020	76	5415487	184	6274020	97	6361137	17
5415024	96	5415520	73	6274032	98	6361139	19
5415025	62	5415569	95	6274045	98	6362765	9
5415046	57	5415632	73	6274072	72	6363524	11
5415085	86	5415633	72	6274084	72	6363525	11
5415103	85	5415634	72	6274086	71	6363526	11
5415105	72	5415683	98	6274096	121	6363527	11
5415187	71	5415712	95	6274124	75	6408026	10
5415189	60	5415779	87	6274127	75	6408027	10
5415205	86	5415832	92	6274291	74	6408028	9
5415214	96	5447648	107	6274314	61	6408030	9
5415216	86	5448103	107	6274315	61	6408032	10
5415218	57	5887000	98	6274359	74	6408033	10
5415226	94	5887046	97	6274360	74	6408036	11
5415232	21	5887078	95	6274425	76	6408037	11
5415242	22	5887089	97	6274431	133	6408038	10
5415248	23	6057088	21	6274532	21	6408399	18
5415252	24	6057094	21	6311225	10		

**Tooling Part Number Index**

Part No.	Page	Part No.	Page	Part No.	Page	Part No.	Page
13126	268	311395	268	1055454	263	1393488	265
13127	268	311396	268	1055469	262	1393494	265
21027	268	312067	268	1055474	262	1393524	264 , 265
58318	268	312253	268	1055475	262	1725837	266
58433	266	312317	268	1055476	262	1775231	227
58483	192	354500	267	1055477	262	M22520/36-01	268
58489	192	603995	267	1055500	263	M22520/36-02	268
59980	267, 268	856402	266	1055831	263	M22520/36-03	268
59981	268	1055420	263	1055832	263	M22520/36-04	268
69477	266	1055439	262, 263	1055833	263	M22520/36-05	268
69710	266	1055440	262, 263	1055834	263	M22520/36-06	268
189721	266	1055441	262, 263	1055835	263	M22520/36-07	268
220015	266	1055442	263	1055836	263	M22520/36-08	268
220220	268	1055443	263	1055837	263	M22520/36-09	268
220221	268	1055444	263	1055838	263	M22520/36-10	268
220222	268	1055445	263	1055839	263	M22520/36-11	268
220224	268	1055446	263	1055840	263	M22520/36-12	268
220241	268	1055447	263	1055841	263	M22520/36-13	268
307581	268	1055448	263	1055842	263	MIL-C-22520/2-01	192
308075	268	1055449	263	1055843	263	MIL-C-22520/5-01	192
311386	268	1055450	263	1213890	266		
311392	268	1055451	263	1311164	191		

**Americas**

**Argentina** – Buenos Aires  
 Phone: +54-11-4733-2200  
 Fax: +54-11-4733-2211

**Brasil** – São Paulo  
 Phone: +55-11-3611-1311  
 Fax: +55-11-3611-0397

**Canada** – Toronto  
 Phone: +905-475-6222  
 Fax: +905-474-5520

**Product Information Center:  
 (Technical Support)**  
 Phone: +905-470-4425  
 Fax: +905-474-5525

**Colombia** – Bogota  
 Phone: +57-1-231-9398  
 Fax: +57-1-660-0206

**Mexico** – Mexico City  
 Phone: +52-55-1106-0800  
 +01-800-733-8926  
 Fax: +52-55-1106-0901

**United States** – Harrisburg, PA  
 Phone: +717-564-0100  
 Fax: +717-986-7575  
**Product Information Center:  
 (Technical Support)**  
 Phone: +800-522-6752  
 Fax: +717-986-7575

**For Latin/South American  
 Countries not shown**  
 Phone: +54-11-4733-2015  
 Fax: +54-11-4733-2083

**Asia/Pacific**

**Australia** – Sydney  
 Phone: +61-2-9554-2600  
 Fax: +61-2-9502-2556  
**Product Information Center:  
 (Technical Support)**  
 Phone: +61-2-9840-8200  
 Fax: +61-2-9634-6188

**India** – Bangalore  
 Phone: +91-80-285-40800  
 Fax: +91-80-285-40820

**Indonesia** – Jakarta  
 Phone: +65-6482-0311  
 Fax: +65-6482-1012

**Japan** – Toyko  
 Phone: +81-44-844-8111  
 Fax: +81-44-812-3207  
**Product Information Center:  
 (Technical Support)**  
 Phone: +81-44-844-8013  
 Fax: +81-44-812-3200

**Korea** – Seoul  
 Phone: +82-2-3415-4500  
 Fax: +82-2-3486-3810

**Malaysia** – Kuala Lumpur  
 Phone: +60-3-78053055  
 Fax: +60-3-78053066

**New Zealand** – Auckland  
 Phone: +64-9-634-4580  
 Fax: +64-9-634-4586

**Philippines** – Makati City  
 Phone: +632-848-0171  
 Fax: +632-867-8661

**People's Republic of China**  
 Hong Kong  
 Phone: +852-2735-1628  
 Fax: +852-2735-0243

Shanghai  
 Phone: +86-21-2407-1588  
 Fax: +86-21-2407-1599

Taiwan – Taipei  
 Phone: +886-2-8768-2788  
 Fax: +886-2-8768-2268

**Singapore** – Singapore  
 Phone: +65-6482-0311  
 Fax: +65-6482-1012

**Thailand** – Bangkok  
 Phone: +66-2-955-0500  
 Fax: +66-2-955-0505

**Vietnam and Indochina** –  
 Ho Chi Minh City  
 Phone: +84-8 930-5546  
 Fax: +84-8 930-3443

**Europe/Middle East/Africa**

**Austria** – Vienna  
 Phone: +43-1 90 5 60-0  
 Fax: +43-1 90 5 60-1333

**Belgium** – Kessel-Lo  
 Phone: +32-16-35-23-00  
 Fax: +32-16-35-23-52

**Bulgaria** – Sofia  
 Phone: +359-2-971-2152  
 Fax: +359-2-971-2153

**Czech Republic** – Kurim  
 Phone: +420-5-41-162-111  
 Fax: +420-5-41-162-223

**Denmark** – Glostrup  
 Phone: +45-43-480-452  
 Fax: +45-43-441-414

**Egypt** – Cairo  
 Phone: +20-2-29 04 281  
 Fax: +20-2-41 92 334

**Estonia** – Tartu  
 Phone: +372-5138-274  
 Fax: +372-7400-779

**Finland** – Helsinki  
 Phone: +358-95-12-34-20  
 Fax: +358-95-12-34-250

**France** – Cergy-Pontoise  
 Phone: +33-1-3420-8888  
 Fax: +33-1-3420-8600  
**Product Information Center:  
 (Technical Support)**  
 Phone: +33-1-3420-8943  
 Fax: +33-1-3420-8623

**Germany** – Bensheim  
 Phone: +49-6251-133-0  
 Fax: +49-6251-133-1600  
**Product Information Center:  
 (Technical Support)**  
 Phone: +49-6251-133-1999  
 Fax: +49-6251-133-1988

**Germany** – Langen  
 Phone: +49-6103-709-0  
 Fax: +49-6103-709-1223

**Germany** – Speyer  
 Phone: +49-6232-30-0  
 Fax: +49-6232-30-2243

**Germany - HTS Division** – Neunkirchen  
 Phone: +49-2247-305-0  
 Fax: +49-2247-305-122

**Greece** – Athens  
 Phone: +30-210-9370-396/397  
 Fax: +30-210-9370-655

**Hungary** – Budapest  
 Phone: +36-1-289-1000  
 Fax: +36-1-289-1010

**Ireland** – Dublin  
 Phone: +353-1-820-3000  
 Fax: +353-1-820-9790

**Israel** – Yokneam  
 Phone: +972-4-959-0508  
 Fax: +972-4-959-0506

**Italy** – Collegno (Torino)  
 Phone: +39-011-4012-111  
 Fax: +39-011-4031116

**Lithuania** – Vilnius  
 Phone: +370-5-2131-402  
 Fax: +370-5-2131-403

**Netherlands** – 's-Hertogenbosch  
 Phone: +31-73-624-62-46  
 Fax: +31-73-621-23-65  
**Product Information Center:  
 (Technical Support)**  
 Phone: +31-73-6246-999  
 Fax: +31-73-6246-998

**Norway** – Nesbru  
 Phone: +47-66-77-8886  
 Fax: +47-66-77-8855

**Poland** – Warsaw  
 Phone: +48-22-45-76-700  
 Fax: +48-22-45-76-720

**Romania** – Bucharest  
 Phone: +40-21-311-3479/3596  
 Fax: +40-21-312-0574

**Russia** – Moscow  
 Phone: +7-495-926-5506/07/08/09  
 Fax: +7-495-926-5505

**Russia** – St. Petersburg  
 Phone: +7-812-718-8192  
 Fax: +7-812-718-8193

**Slovenia** – Ljubljana  
 Phone: +386-1561-3270  
 Fax: +386-1561-3240

**South Africa** – Port Elizabeth  
 Phone: +2741-503-4500  
 Fax: +2741-581-0440

**Spain** – Barcelona  
 Phone: +34-93-291-0330  
 Fax: +34-93-201-7879  
**Product Information Center:  
 (Technical Support):**  
 Phone: +34-93-291-0330  
 Fax: +34-93-200-3779

**Sweden** – Upplands Väsby  
 Phone: +46-8-50-72-50-00  
 Fax: +46-8-50-72-50-01

**Switzerland** – Steinach  
 Phone: +41-71-447-0447  
 Fax: +41-71-447-0444

**Turkey** – Istanbul  
 Phone: +90-212-281-8181/2/3  
 Fax: +90-212-281-8184

**Ukraine** – Kiev  
 Phone: +380-044-206-2265  
 Fax: +380-044-206-2264

**United Kingdom** – Swindon  
 Phone: +44-8706-080-208  
 Fax: +44-1793-572-109  
**Product Information Center:  
 (Technical Support)**  
 Freephone GB: 0800-267-666  
 Phone: +44-208-420-8341 or 8343  
 +44-208-420-8081

**For Middle East/African Countries  
 Not Shown**  
 Phone: +33-1-3420-8866  
 Fax: +33-1-3420-8300

**Tyco Electronics Corporation**  
Harrisburg, Pennsylvania

1307191 Revised 3-07 3M-LUG-FP

[tycoelectronics.com](http://tycoelectronics.com)

