

THIS DRAWING IS UNPUBLISHED. RELEASED FOR PUBLICATION ,19 .
 © COPYRIGHT 19 BY AMP INCORPORATED. ALL INTERNATIONAL RIGHTS RESERVED.

LOC		DIST		REVISIONS				DATE	APPD
P	F	ZONE	LTR	DESCRIPTION					
G	14			B	REV & REDRAWN PER 0720-0040-93		4-8-93	APP DAP	

METRIC
 DIMENSIONS LISTED IN mm [INCHES]

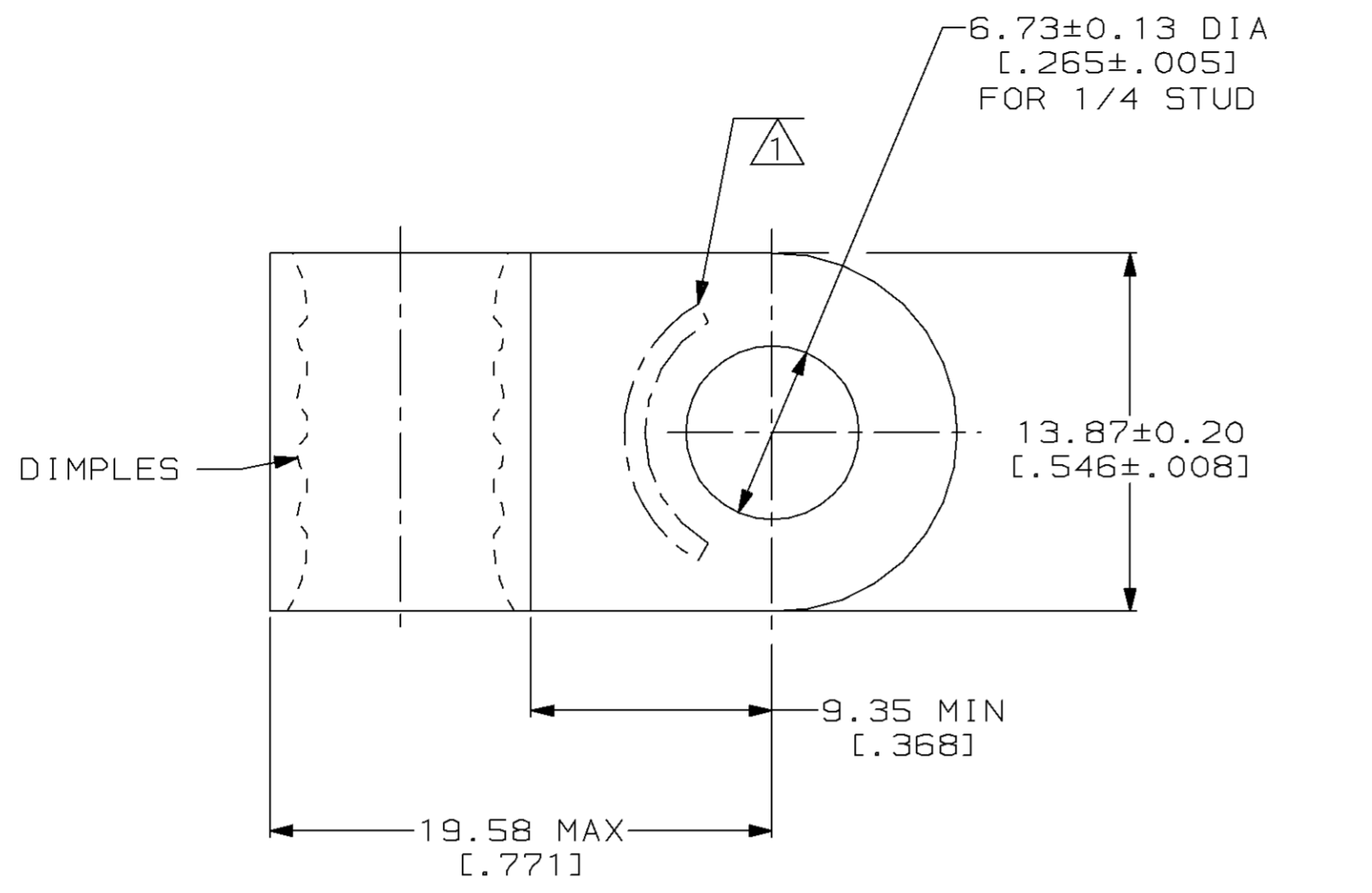

AMP WIRE RANGE	UL E13288 Listed
4 AWG SOLID OR STRANDED	4 AWG STRANDED
SR LR7189 Certified	MILITARY P/N AND CLASS
4 AWG SOLID OR STRANDED	NOT APPLICABLE

△ STAMP AMP 4W* APPROX AS SHOWN

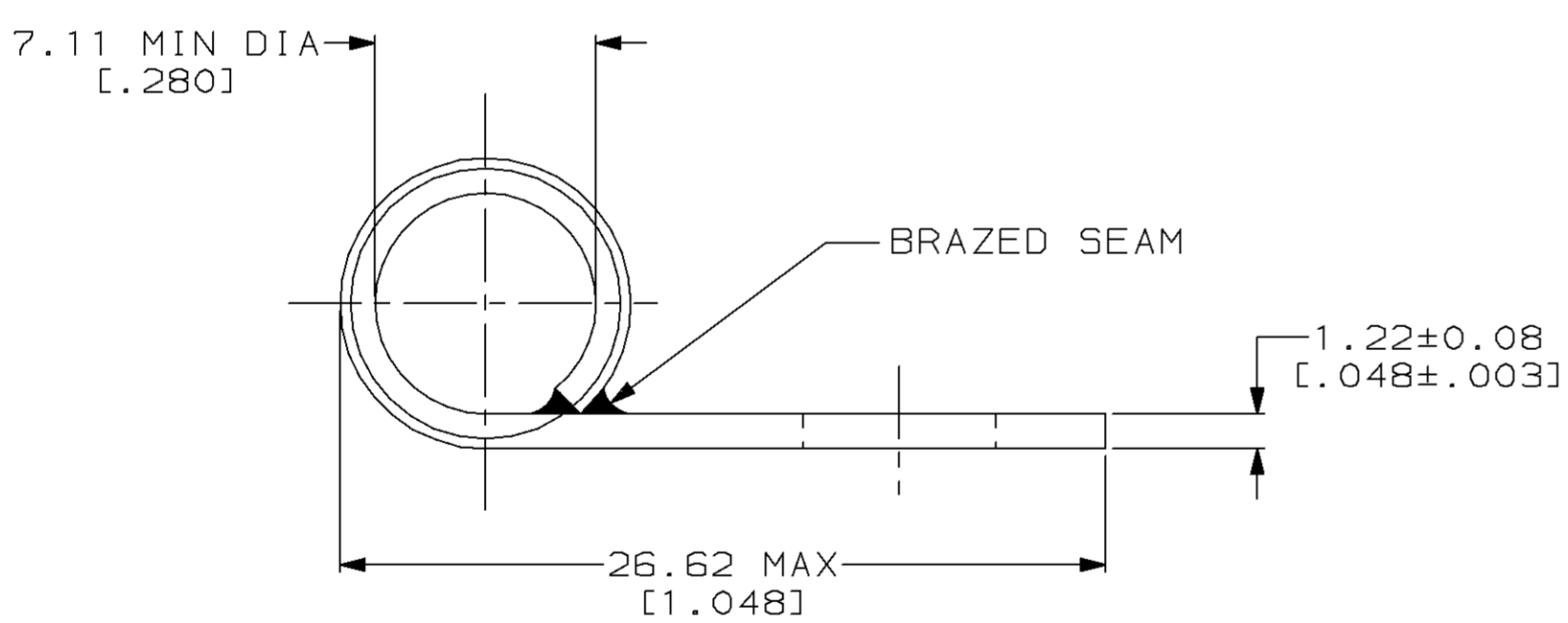

AMP INCORPORATED CUSTOMER SERVICE SYSTEMS		MAX RECOMMENDED OPERATING TEMPERATURE: 170°C MAX	DO NOT SCALE PRINT. UNLESS SPECIFIED DIMENSIONS IN mm [INCHES] TOLERANCES ON: 2 PLC DEC ± - 3 PLC DEC ± - ANGLES ± -	DR 4-8-93 TA BRINKMAN	AMP AMP Incorporated Harrisburg, PA 17105-3608
FOR ADDITIONAL PRODUCT INFORMATION OR COPIES OF DRAWINGS AND TECHNICAL DOCUMENTS	PRODUCT INFORMATION CENTER 1-800-522-6752	VOLTAGE RATING: NOT APPLICABLE	MATERIAL COPPER PER ASTM B-152 ANNEALED	CHK 4-8-93 DA PATTERSON	
FOR APPLICATION TOOLING INFORMATION	TOOLING ASSISTANCE CENTER 1-800-722-1111	WIRE CROSS SECTIONAL AREA RANGE: 16.8-26.7MM² [33,100-52,600] CIR MILS SOLID OR STRANDED	FINISH TIN PLATE 0.00254[.000100] MIN THK PER MIL-T-10727	APPD 4-8-93 DE MILLER	SIZE CAGE CODE DRAWING NO
FOR ORDER ENTRY	1-800-526-5142	THIS DRAWING IS A CONTROLLED DOCUMENT FOR AMP INCORPORATED. IT IS SUBJECT TO CHANGE AND THE CONTROLLING ENGINEERING ORGANIZATION SHOULD BE CONTACTED FOR THE LATEST REVISION.		APPD 4-8-93 JL MECKLEY	SCALE CAGE CODE DRAWING NO
				PRODUCT SPEC -	SCALE 4:1
				APPLICATION SPEC -	SHEET 1 OF 1
				WEIGHT -	