

# DrGaN<sup>PLUS</sup> Development Board EPC9201/3 Quick Start Guide

*Optimized Half-Bridge Circuit for eGaN<sup>®</sup> FETs*

EPC9201 Top side

EPC9203 Top side

11 x 12 mm

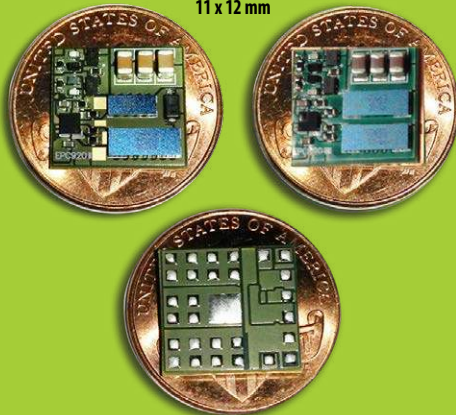

Mounting side



## DESCRIPTION

This development board, measuring 11 x 12 mm, contains two enhancement mode (eGaN®) field effect transistors (FETs) arranged in a half bridge configuration with an onboard Texas Instruments LM5113 gate driver and is driven by a single PWM input. The purpose of these development boards is to simplify the evaluation process by optimizing the layout and including all the critical components on a single board that can be easily connected into any existing converter. A complete block diagram of the circuit is given in figure 1.

For more information on EPC’s family of eGaN FETs and ICs, please refer to the datasheets available from EPC at [www.epc-co.com](http://www.epc-co.com). The data-sheet should be read in conjunction with this quick start guide

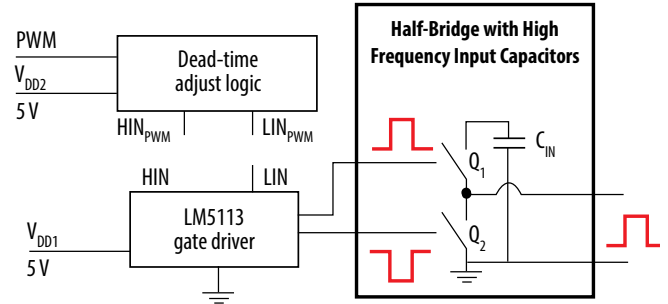

Figure 1: Block diagram of EPC9201/3 development board.

## THERMAL CONSIDERATIONS

The development board is intended for bench evaluation with low ambient temperature and convection cooling. The addition of heat-sinking and forced air cooling can significantly increase the current rating of these devices, but care must be taken to not exceed the absolute maximum die temperature of 150°C.

**NOTE:** The development board does not have any current or thermal protection on board.

Table 1: Performance Summary (T<sub>A</sub> = 25°C) EPC9201/3

Symbol	Parameter	Conditions	Min	Max	Units
V <sub>DD</sub>	Gate Drive Input Supply Range		4.5	5	V
V <sub>INP</sub>	Bus Input Voltage Range	When using 30 V rated EPC9201		20*	V
		When using 80 V rated EPC9203		60*	V
V <sub>OUT</sub>	Switch Node Output Voltage	When using 30 V rated EPC9201		30	V
		When using 80 V rated EPC9203		80	V
I <sub>OUT</sub>	Switch Node Output Current	When using 30 V rated EPC9201		40*	A
		When using 80 V rated EPC9203		20*	A
V <sub>PWM</sub>	PWM Logic Input Voltage Threshold	Input 'High'	3.5	6	V
		Input 'Low'	0	1.5	V
	Minimum 'High' State Input Pulse Width	VPWM rise and fall time < 10 ns	60		ns
	Minimum 'Low' State Input Pulse Width	VPWM rise and fall time < 10 ns	200#		ns

\* Assumes inductive load, maximum current depends on die temperature – actual maximum current will be subject to switching frequency, bus voltage and thermals.

# Limited by time needed to 'refresh' high side bootstrap supply voltage.

PWM INPUT

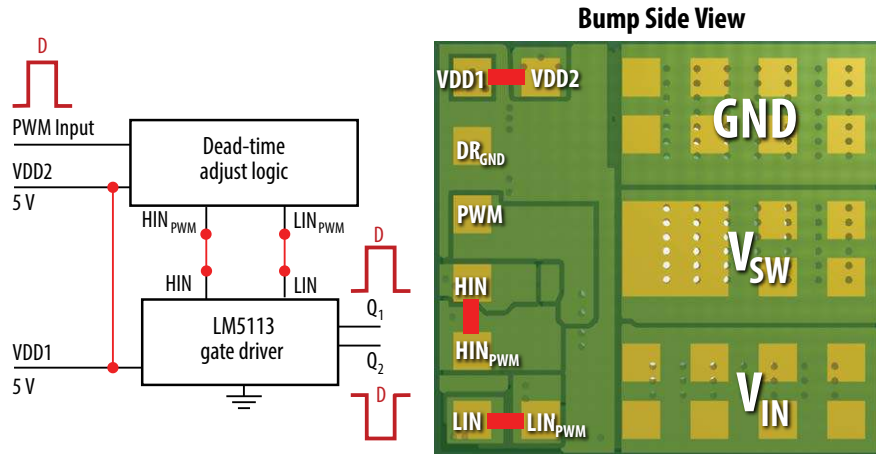

Figure 2: Single PWM input setup.

**NOTE:** Single PWM timing optimized for most buck converter applications. For other applications or desired timing settings, two PWM input setting recommended.

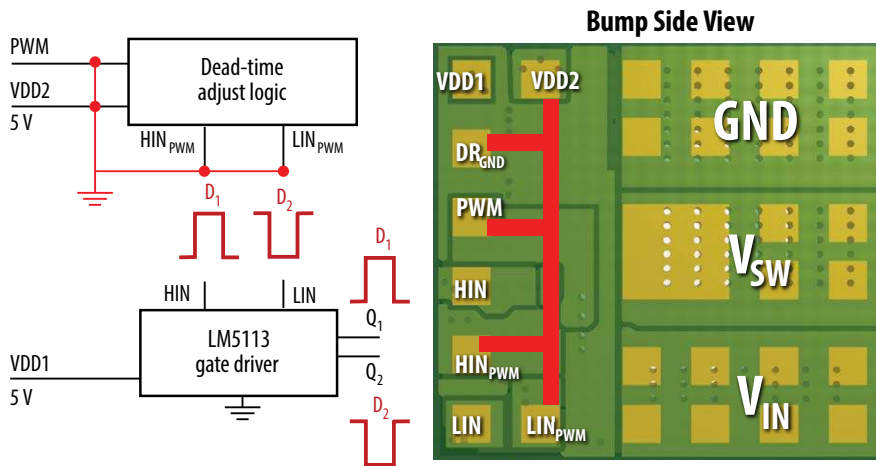

Figure 3: Two PWM input setup.

TYPICAL PERFORMANCE

EPC9201

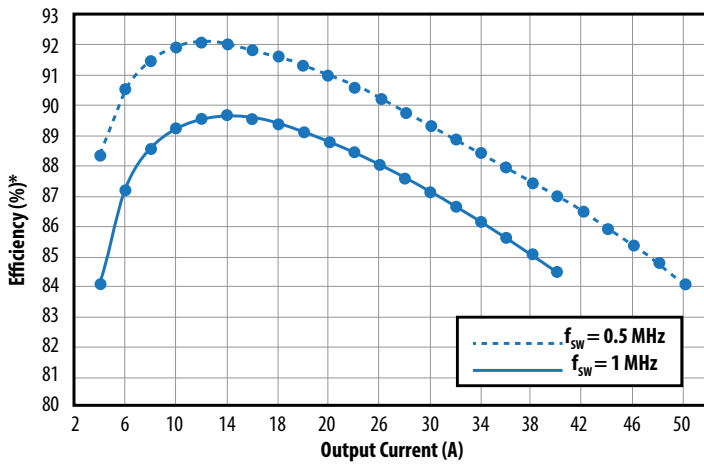

Figure 6: Typical efficiency for  $V_{IN} = 12\text{ V}$  to  $V_{OUT} = 1\text{ V}$ ,  $L = 250\text{ nH}$

\*Total system efficiency including power stage, inductor, driver, capacitors, and PCB losses.

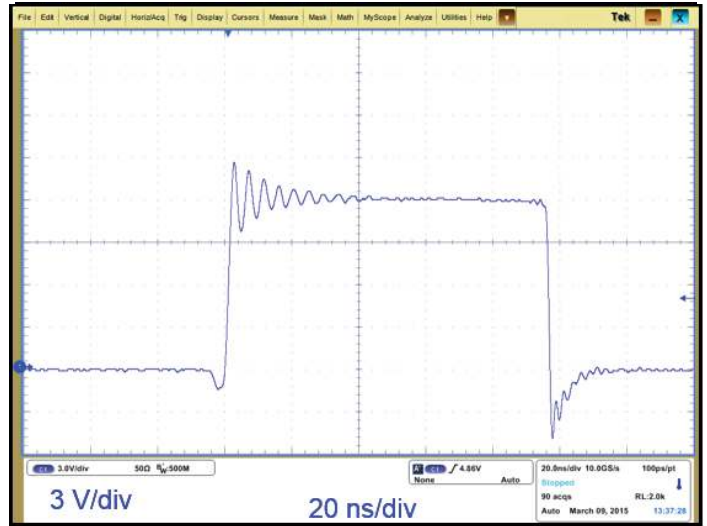

Figure 4: Typical switch node voltage waveform for  $V_{IN} = 12\text{ V}$  to  $V_{OUT} = 1\text{ V}$ ,  $I_{OUT} = 40\text{ A}$ ,  $f_{SW} = 1\text{ MHz}$  buck converter.

EPC9203

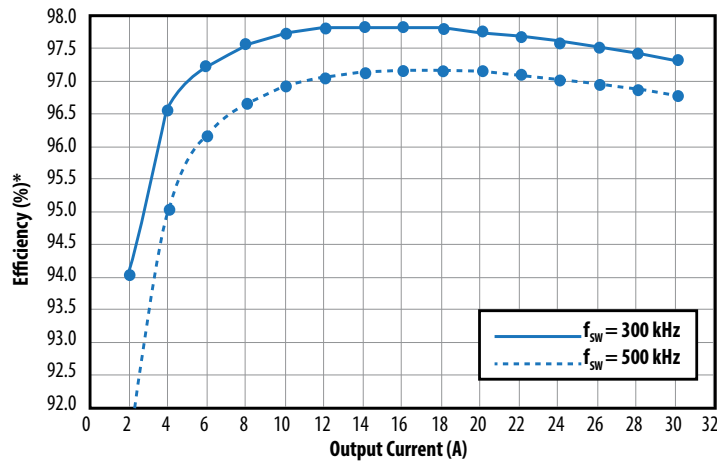

Figure 7: Typical efficiency for  $V_{IN} = 48\text{ V}$  to  $V_{OUT} = 12\text{ V}$ ,  $L = 4.7\text{ }\mu\text{H}$

\*Total system efficiency including power stage, inductor, driver, capacitors, and PCB losses.

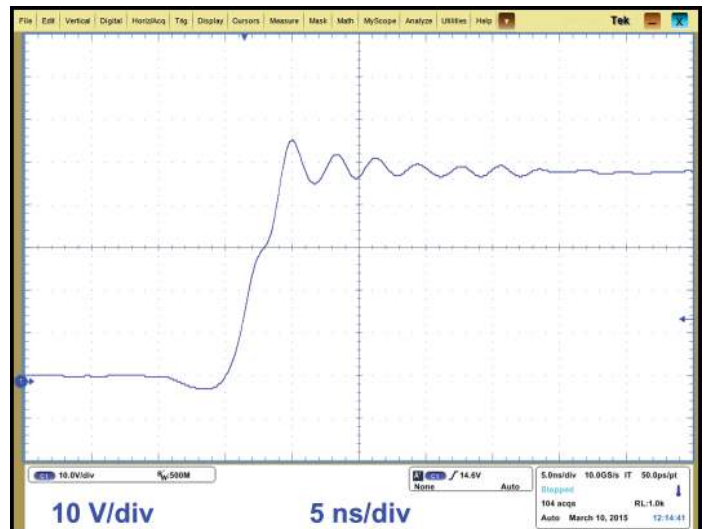

Figure 5: Typical switch node voltage waveform for  $V_{IN} = 48\text{ V}$  to  $V_{OUT} = 12\text{ V}$ ,  $I_{OUT} = 20\text{ A}$ ,  $f_{SW} = 500\text{ kHz}$  buck converter

## DESIGN CONSIDERATIONS

To improve the electrical and thermal performance of the DrGaN<sup>PLUS</sup> development board some design considerations are recommended:

1. Large copper planes should be connected to the development board to improve thermal performance as shown in figures 8 through 11. If filled vias are used in the board design, thermal vias should be placed under the device as shown in figure 8 to better distribute heat through buried inner layers. For a design without filled vias, thermal vias should be located outside of the development board.
2. To reduce conduction losses, the inductor and output capacitors should be located in close proximity to the development board.
3. The smaller IC ground connection (pin 6 in mechanical drawings), should be isolated from the power ground connection (pin 3 in mechanical drawings).
4. If additional input filter capacitance is required, it can be placed outside the module. Due to the internal on-board input capacitance, minimizing the distance of the additional input capacitors to the development board, while preferred, is not a design requirement.

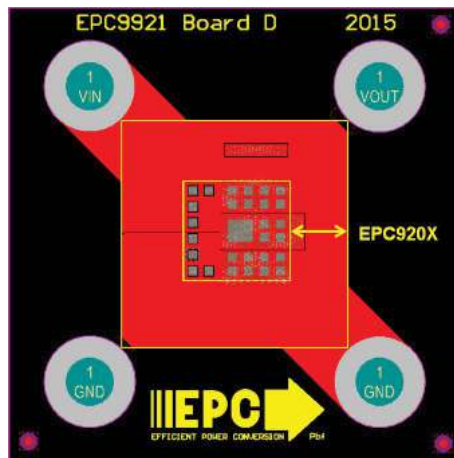

Figure 8: Top layer without filled thermal vias.

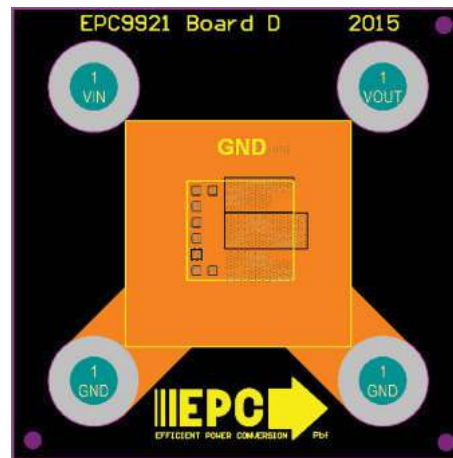

Figure 9: Inner layout 1 layout.

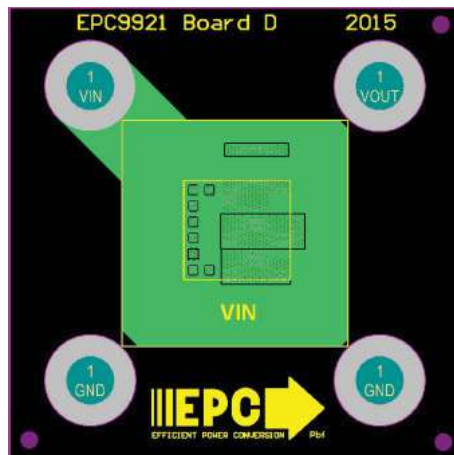

Figure 10: Inner layout 2 layout.

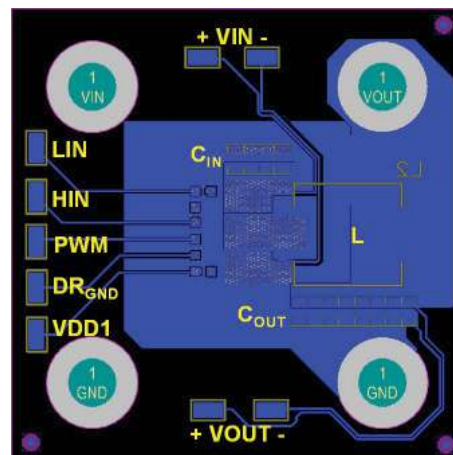
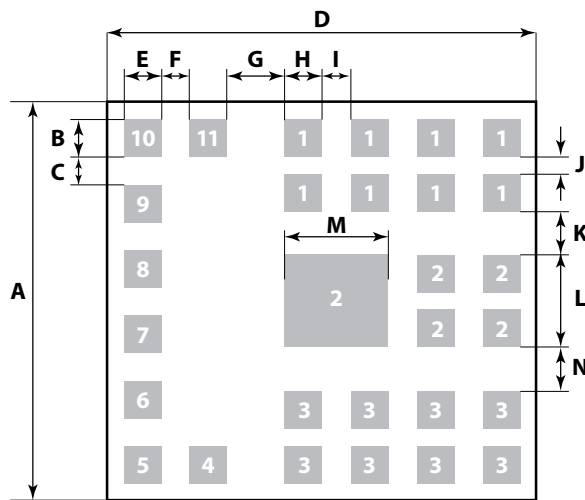
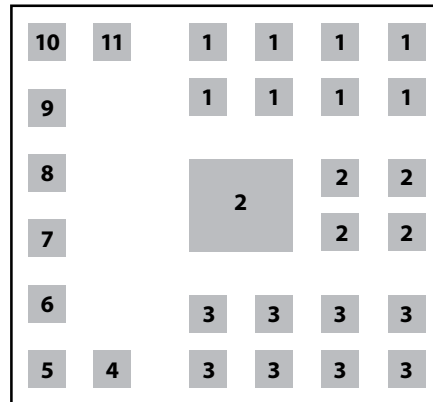

Figure 11: Bottom layer layout.



	Millimeter
A	11.00
B	1.00
C	0.80
D	12.00
E	1.00
F	0.80
G	1.65
H	1.00
I	0.80
J	0.50
K	1.25
L	2.50
M	2.80
N	1.25



- Pin 1: Input Voltage,  $V_{IN}$
- Pin 2: Switching Node,  $V_{SW}$
- Pin 3: Power Ground,  $P_{GND}$
- Pin 4: Driver Voltage,  $V_{DD2}$
- Pin 5: Driver Voltage,  $V_{DD1}$
- Pin 6: Driver Ground,  $DR_{GND}$
- Pin 7: PWM Input, PWM
- Pin 8: High Side Input, HIN
- Pin 9: PWM High Side Input,  $HIN_{PWN}$
- Pin 10: Low Side Input, LIN
- Pin 11: PWM Low Side Input,  $LIN_{PWN}$

Table 3: Bill of Materials - EPC9201/3

Item	Qty	Reference	Part Description	Manufacturer	Part Number
1	3	CIN1, CIN2, CIN3	Capacitor, 4.7 $\mu$ F, 10%, 50 V, X5R, 0805 (EPC9201) Capacitor, 1 $\mu$ F, 20%, 100 V, X7S, 0805 (EPC9203)	TDK	C2012X5R1H475K125AB (EPC9201) C2012X7S2A105M125AB (EPC9203)
2	2	Q1, Q2	EPC9201: 40 V 33 A eGaN FET / 30 V 60 A eGaN FET EPC9203: 80 V 60 A eGaN FET	EPC	EPC2015C / EPC2023 (EPC9201) EPC2021 (EPC9203)
3	4	R19, R20, R23, R24	Resistor, 0 $\Omega$ , 1/16 W	Stackpole	RMCF0402ZT0R00TR
4	1	C9	Capacitor, 0.1 $\mu$ F, 10%, 25 V, X5R	TDK	C1005X5R1E104K050BC
5	1	C19	Capacitor, 1 $\mu$ F, 10%, 16 V, X5R	TDK	C1005X5R1C105K050BC
6	1	U2	I.C., Gate driver	Texas Instruments	LM5113
7	2	D1, D2	Diode Schottky 40 V 0.12 A SOD882	NXP	BAS40L,315
8	1	U4	IC GATE AND UHS 2-INP 6-MICROPAK	Fairchild	NC7SZ08L6X
9	1	U1	IC GATE NAND UHS 2-INP 6MICROPAK	Fairchild	NC7SZ00L6X
10	1	R1	Resistor, 10K $\Omega$ 1/20 W 1% 0201	Stackpole	MCF0201FT10K0
11	2	C6, C7	Capacitor, CER 100 pF 50 V 5% NP0 0402	Murata	GRM1555C1H101JA01D
12	1	D3	Schottky Diode, 30 V, 2 A MICROSMP (EPC9201 only)	Vishay	MSS2P3-M3/89A
13	1	R4	Resistor, 3.92 $\Omega$ 1/16 W 1% 0402 SMD	Stackpole	RMCF0402FT3R92
14	1	R5	Resistor, 20 $\Omega$ 1/16 W 1% 0402 SMD (EPC9201) Resistor, 100 $\Omega$ 1/16 W 1% 0402 SMD (EPC9203)	Stackpole	RMCF0402FT20R0CT (EPC9201) RMCF0402FT100RCT (EPC9203)

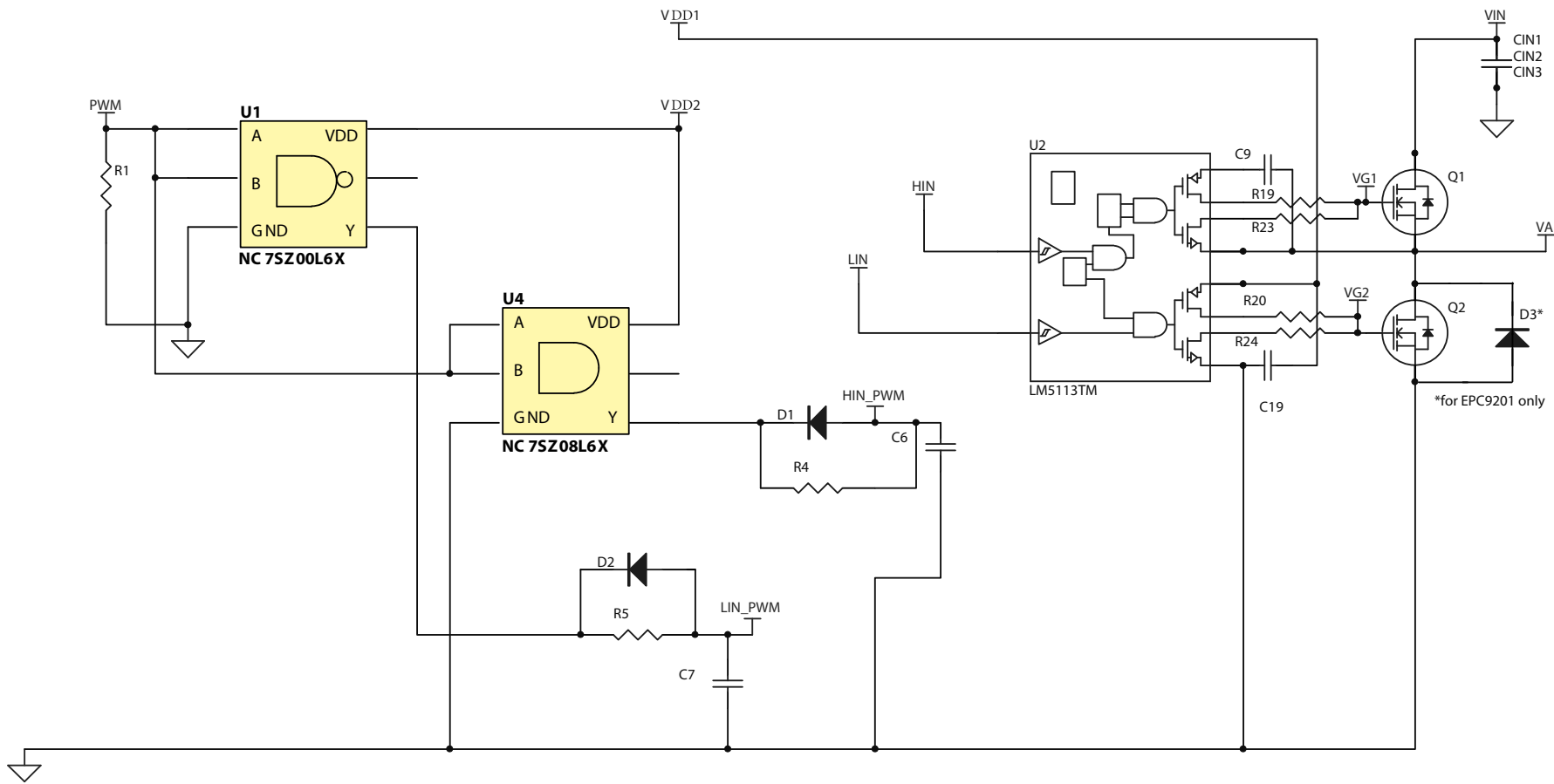

Figure 12: Full schematic EPC9201/EPC9203 Rev 2

## For More Information:

Please contact [info@epc-co.com](mailto:info@epc-co.com)  
or your local sales representative

Visit our website:  
[www.epc-co.com](http://www.epc-co.com)

Sign-up to receive  
EPC updates at  
[bit.ly/EPCupdates](http://bit.ly/EPCupdates)  
or text "EPC" to 22828



EPC Products are distributed through Digi-Key.  
[www.digikey.com](http://www.digikey.com)

### Demonstration Board Notification

**The EPC9201/3 board is intended for product evaluation purposes only. It is not intended for commercial use nor is it FCC approved for resale.** Replace components on the Evaluation Board only with those parts shown on the parts list (or Bill of Materials) in the Quick Start Guide. Contact an authorized EPC representative with any questions. This board is intended to be used by certified professionals, in a lab environment, following proper safety procedures. Use at your own risk.

As an evaluation tool, this board is not designed for compliance with the European Union directive on electromagnetic compatibility or any other such directives or regulations. As board builds are at times subject to product availability, it is possible that boards may contain components or assembly materials that are not RoHS compliant. Efficient Power Conversion Corporation (EPC) makes no guarantee that the purchased board is 100% RoHS compliant.

The Evaluation board (or kit) is for demonstration purposes only and neither the Board nor this Quick Start Guide constitute a sales contract or create any kind of warranty, whether express or implied, as to the applications or products involved.

Disclaimer: EPC reserves the right at any time, without notice, to make changes to any products described herein to improve reliability, function, or design. EPC does not assume any liability arising out of the application or use of any product or circuit described herein; neither does it convey any license under its patent rights, or other intellectual property whatsoever, nor the rights of others.