

APPROVED: _____
 DATE: _____ TITLE: _____

Rev	AWO #	Description	Date	Appr
-		RELEASED	5/24/16	
A		UPDATE DRAWING	8/31/21	JJ/RC

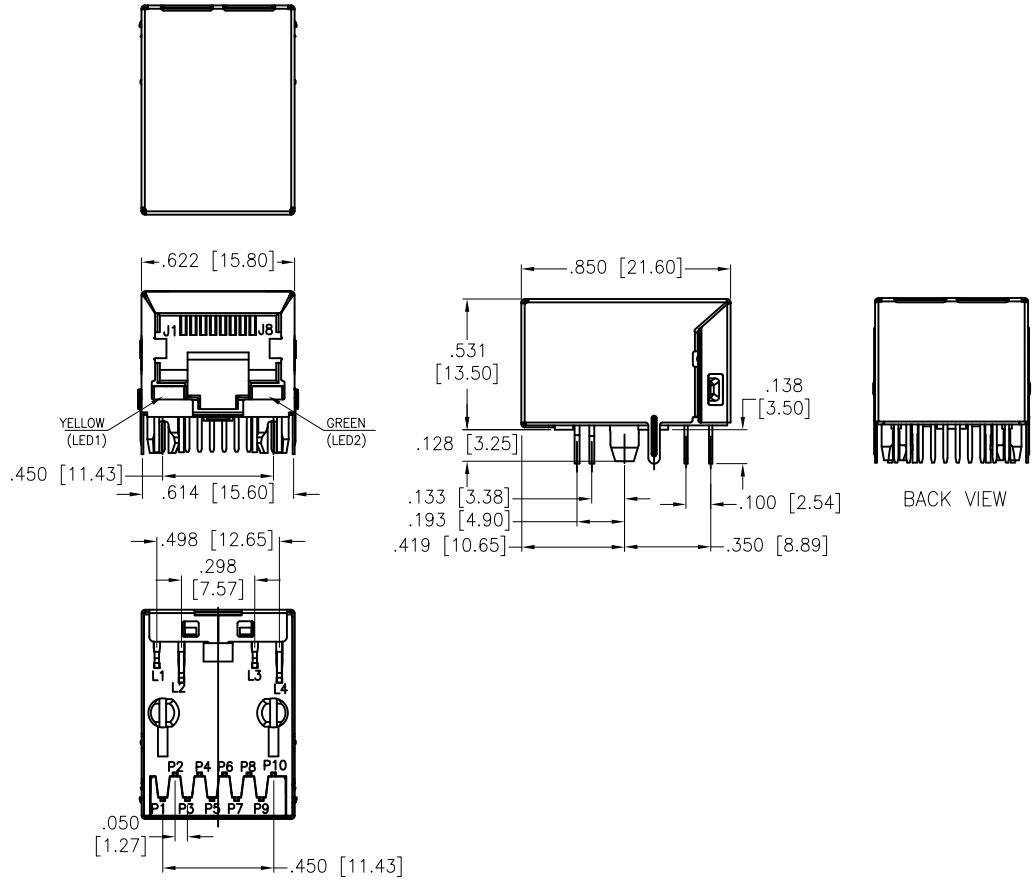

SPECIFICATIONS:
 Material:
 Housing: Hi-Temp Thermoplastic, rated UL 94V-0, Color: Black
 Contacts: Phosphor Bronze
 Solder Tail Terminal: Brass, Tin plated
 Shield: Stainless, Nuckel Platrd
 Flat contact
 Gold over Nickel underplate on contact area,
 Tin over Nickel underplate on solder tails
 Electrical:
 Insulation resistance: 500 Mohms min
 Dielectric withstanding voltage: 1,500 VAC or 2,250 VDC for 1 minute
 Mechanical:
 Temperature Rating:
 Operating temperature: 0°C to +70°C
 Environmental:
 Lead free, RoHS compliant.

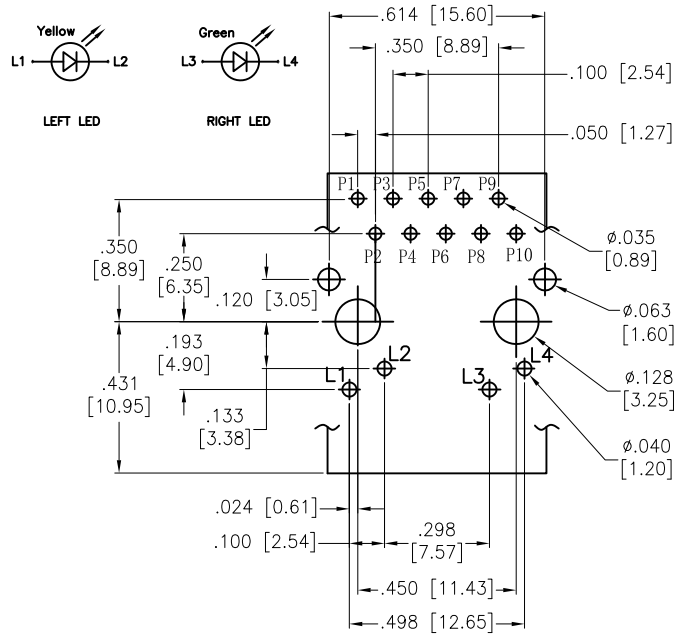

UNLESS OTHERWISE SPECIFIED ALL DIMENSIONS ARE INCHES [MM]. TOLERANCES: EXCEPT AS NOTED

INCHES		HOLES	
.X	± .10	Ø.X	± .10
.XX	± .020	Ø.XX	± .015
.XXX	± .015	Ø.XXX	± .010



909 Rahway Avenue,
 Union, NJ 07083
 Phone: 908-687-5000
 Fax: 908-687-5710

DRAWN	AY	5/24/16
CHECKED	MY	5/24/16
APPROVED		

TITLE
**MODULAR JACK GANGED, 1 PORT, 8P8C
 RJ45, W/ LED1 YELLOW LED2 GREEN**

THIS DRAWING CONTAINS INFORMATION THAT IS PROPRIETARY AND SHOULD NOT BE USED WITHOUT PRIOR WRITTEN PERMISSION FROM ADAM TECH

SIZE X	PART NO. MTJ-88TX1-FSD-D1LG-M224Y	REV. A
REF: S00101C	SCALE: NTS	SHEET 1 OF 2

6

5

4

3

2

1

Rev	AWO #	Description	Date	Appr
SEE SHT 1 OF 2 FOR REVISION				

APPROVED: _____
 DATE: _____ TITLE: _____

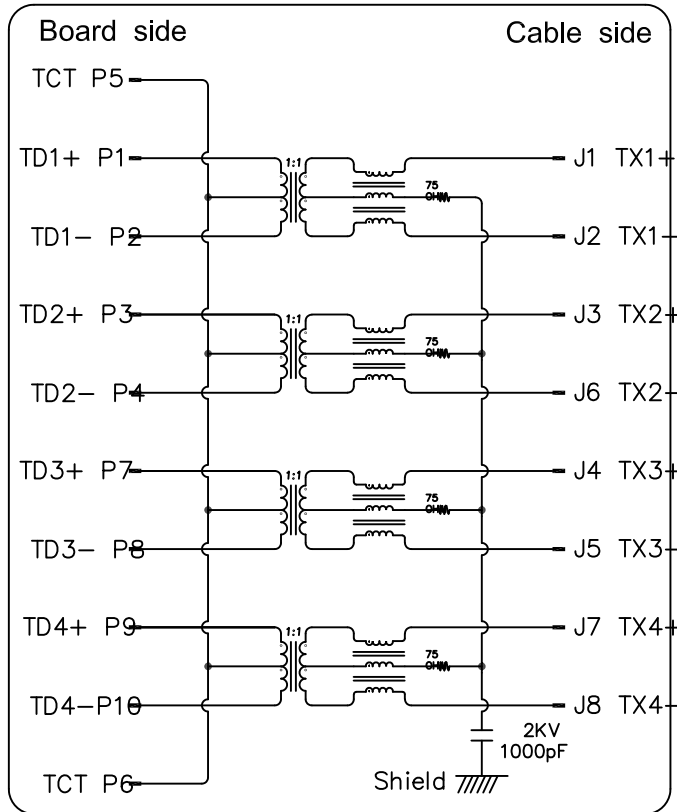

ELECTRICAL CHARACTERISTICS :

- INSERTION LOSS :**
 - 1~100 MHz -1.0dB MAX.
- RETURN LOSS(LOAD 100Ω) :**
 - 1~30 MHz -18dB MIN
 - 30~60 MHz -16dB MIN
 - 60~80 MHz -12dB MIN
 - 80~100 MHz -10dB MIN
- COMMON MODE REJECTION**
 - 1~100 MHz -30dB MIN
- CROSS TALK**
 - 1~100 MHz -30dB MIN
- INDUCTANCE @ 100KHz, 0.1V, 8mA DC BIAS**
 - (P1-P2),(P3-P4),(P7-P8),(P9-P10) : 350 uH MIN
- DCR**
 - (J1-J2),(J3-J6),(J4-J5),(J7-J8) : 1.2 OHM MAX
- HI-POT TEST**
 - BOARD SIDE TO CABLE SIDE : 1500VAC 60S OR 2250VDC 60S
- URNS RATION 100KHz**
 - (P1-P2) : (J1-J2) = 1:1 ±%3
 - (P3-P4) : (J3-J6) = 1:1 ±%3
 - (P7-P8) : (J4-J5) = 1:1 ±%3
 - (P9-P10) : (J7-J8) = 1:1 ±%3

UNLESS OTHERWISE SPECIFIED ALL DIMENSIONS ARE INCHES [MM]. TOLERANCES: EXCEPT AS NOTED

INCHES		HOLES	
.X ± .10	∅.X ± .10	.XX ± .020	∅.XX ± .015
.XXX ± .015	∅.XXX ± .010		

DRAWN	AY	5/24/16
CHECKED	MY	5/24/16
APPROVED		

THIS DRAWING CONTAINS INFORMATION THAT IS PROPRIETARY AND SHOULD NOT BE USED WITHOUT PRIOR WRITTEN PERMISSION FROM ADAM TECH

ADAM TECH 909 Rahway Avenue,
 Union, NJ 07083
 Phone: 908-687-5000
 Fax: 908-687-5710

TITLE: MODULAR JACK GANGED, 1 PORT, 8P8C
 RJ45, W/ LED1 YELLOW LED2 GREEN

SIZE	PART NO.	REV.
X	MTJ-88TX1-FSD-D1LG-M224Y	A

REF: S00101C SCALE: NTS SHEET 2 OF 2

6

5

4

3

2

1