

**TOP VIEW**

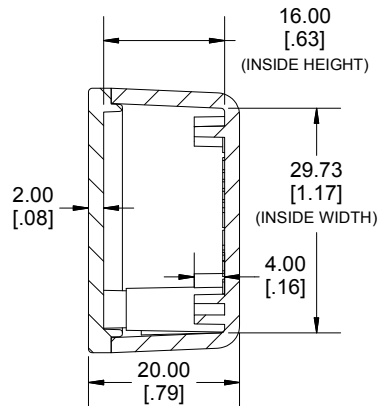

**END VIEW SECTION B-B**

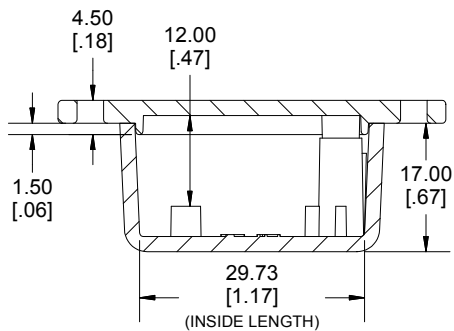
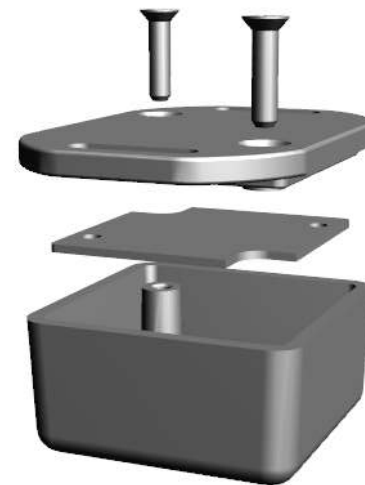

**SIDE VIEW SECTION A-A**

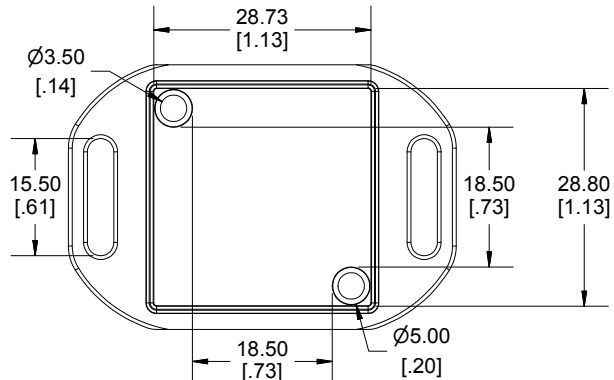

**INSIDE LID**

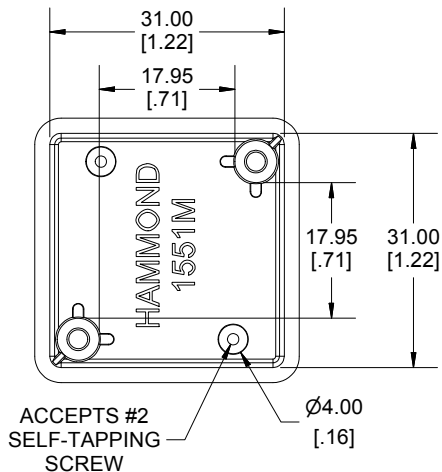

**INSIDE BOX**

ACCEPTS #2 SELF-TAPPING SCREW

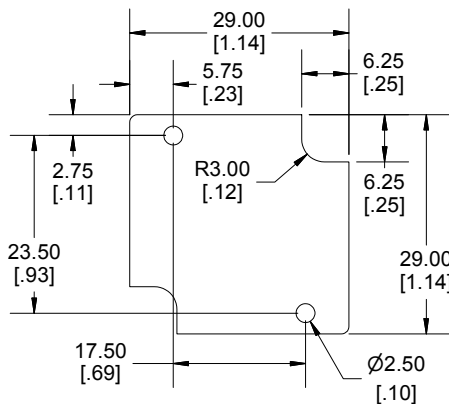

**MAXIMUM P.C. BOARD SIZE**

Dimensions:  
mm  
[inches]

Enclosures can be Factory Modified ( Milling, Drilling, Printing etc.)  
Contact Factory [mjm@hammondmfg.com](mailto:mjm@hammondmfg.com) for quotes  
Solid models of this enclosure available in STEP or IGES.  
(Part number and text placement/orientation on our products are subject to change, we do not recommend using them as a locating reference for modification purposes)

**NOTE**

Purchased assembly includes box, lid, 2 cover screws.  
Enclosure molded from general purpose ABS Plastic.  
Other materials / colours available consult factory.

**Recommended Torque : (35-43) Ozf.in / (25-30) cN.m**

**PART NUMBERS**

**1551MFL Enclosure**

Black Enclosure - Ral 9011 - UL94 - HB	1551MFLBK
Gray Enclosure - RAL 7035 - UL94 - HB	1551MFLGY
Tranlucent Blue - UL94 - HB	1551MFLTBU

**ACCESSORIES**

Black Cover Screws #4 X 1/2" Self-tapping	1591TS100BK (Pkg 100)
Plated Cover Screws #4 X 1/2" Self-tapping	1591TS100 (Pkg 100)
P.C. Board Screws	1551ATS50 (Pkg 50)
#2 x 3/16" self-tapping (4.8mm)	1551ATS100 (Pkg 100)

