

7022X Series SMT LEDs 1206 Package Size

Description and Features

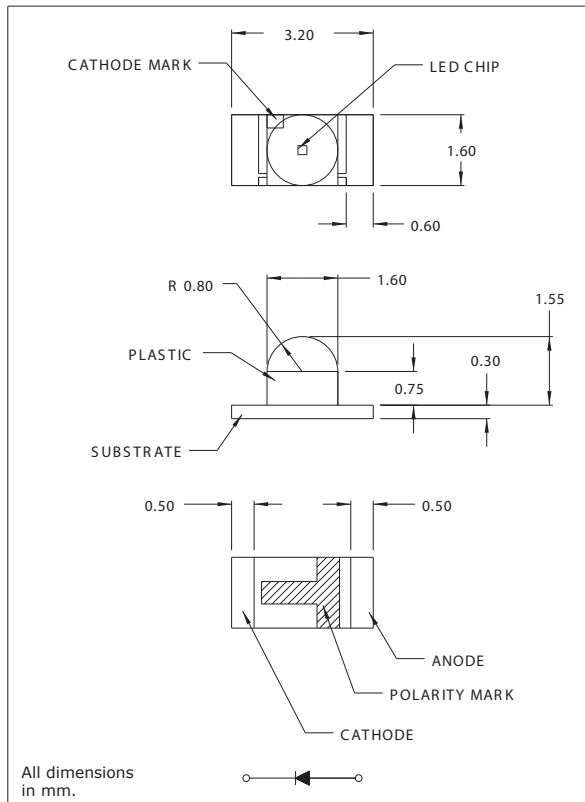

Surface Mount Technology

- Tape and reel packaged for high-speed autoinsertion.
- Convection and vapor-phase reflow compatible.
- Compact form enables high density placement.
- Packaged 2000 per reel.

Leading Edge LED Optoelectronic Performance

- Consistent high brightness.

Exceptional Reliability

- Stringent process controls assure quality.
- Extensive qualification testing to meet strictest requirements.
- Designed to permit easy post-reflow solder joint inspection.
- Refer to "Solder Pad Geometry 1.pdf"

Electro-Optical Characteristics and Ratings

PART NUMBER	7022X1	7022X3	7022X5	7022X7	7022X11	7022X15
Output Color	Red	Orange	Green	Yellow	Red	Green
Diffused/Non-Diffused	Non-Diffused	Non-Diffused	Non-Diffused	Non-Diffused	Non-Diffused	Non-Diffused
Package Color	Clear	Clear	Clear	Clear	Clear	Clear
Power Dissipation (mW)	57.5	70	70	70	70	70
Peak Forward Current Max. (mA)	60	60	60	60	60	60
Reverse Voltage (V)	4	4	4	4	4	4
Operating temperature (°C)	-40 to +85	-40 to +85	-40 to +85	-40 to +85	-40 to +85	-40 to +85
Storage Temperature (°C)	-40 to +100	-40 to +100	-40 to +100	-40 to +100	-40 to +100	-40 to +100
Forward Voltage Typ. (IF=20mA)	1.7	2.2	2.1	2.2	2.0	2.1
Forward Voltage Max. (IF=20mA)	2.3	2.8	2.8	2.8	2.8	2.8
Lead Solder Time @ 260°C (seconds)	5	5	5	5	5	5
Luminous Intensity Min. (IF=20mA)	25.0	10.0	15.0	10.0	10.0	6.0
Luminous Intensity Typ. (IF=20mA)	52.0	25.0	38.0	30.0	22.0	13.0
Peak Wavelength (IF=20mA)	660	605	560	580	630	555
Rated Current (mA)	20	20	20	20	20	20