

FAN1582

3A Adjustable/Fixed Ultra Low Dropout Linear Regulator

Features

- Ultra Low dropout voltage, 0.4V typical at 3A
- Remote sense operation
- Fast transient response
- Load regulation: 0.05% typical
- 0.5% initial accuracy
- On-chip thermal limiting
- 5-Pin TO-252 DPAK, and TO-263 packages

Applications

- Support of GTL+ bus supply
- Low voltage logic supply
- Embedded Processor supplies
- Split plane regulator
- 2.5V, and 1.8V Logic Families
- DDR Termination Supply

Description

The FAN1582, FAN1582-1.5, and FAN1582-2.5 are ultra-low dropout regulators with 3A output current capability. These devices have been optimized for low voltage applications including V_{TT} bus termination, where transient response and minimum input voltage are critical. The FAN1582 is ideal for low voltage microprocessor applications requiring a regulated output from 1.3V to 5.7V with a power input supply of 1.75V to 6.5V. The FAN1582-1.5 offers fixed 1.5V with 3A current capabilities for GTL+ bus V_{TT} termination. The FAN1582-2.5 offers fixed 2.5V with 3A current capability for logic IC operation and processors while minimizing the overall power dissipation.

Current limit ensures controlled short-circuit current. On-chip thermal limiting provides protection against any combination of overload and ambient temperature that would create excessive junction temperatures.

The FAN1582 series regulators are available in the 5-Pin TO-252 DPAK, and TO-263 power packages.

Typical Applications

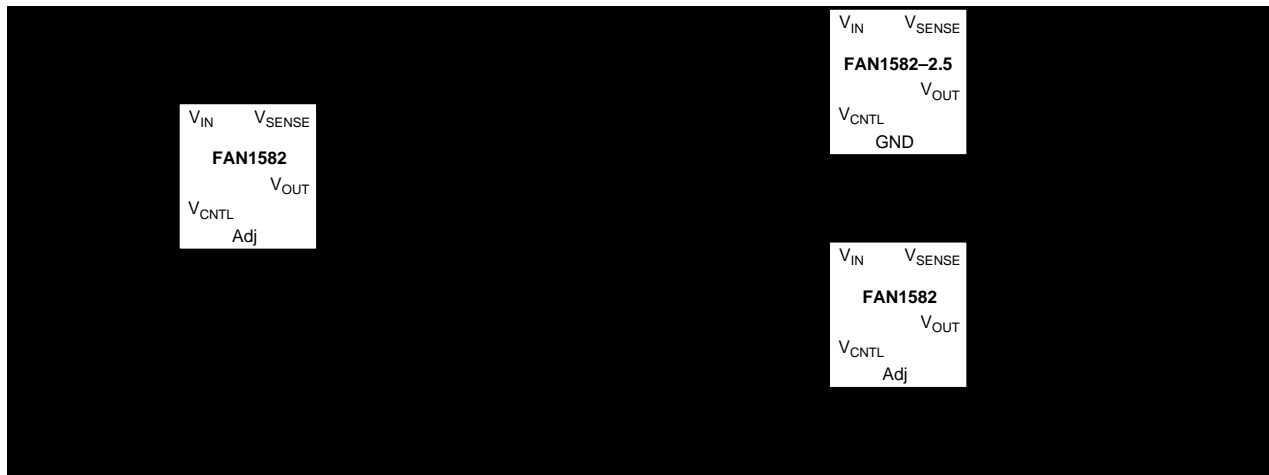

Pin Assignments

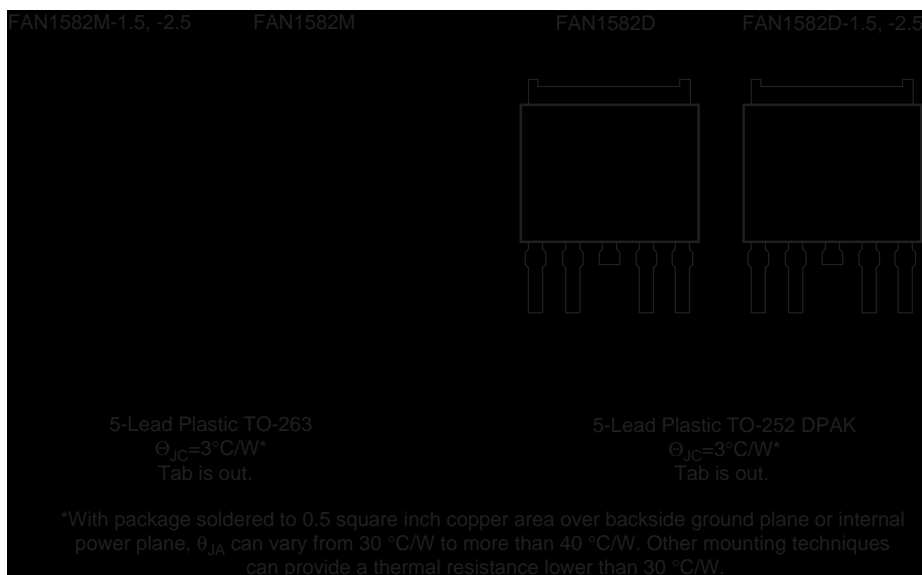

Pin Definitions

Pin Number	Pin Name	Pin Function Description
1	VSense	Remote Voltage Sense. Connect this pin to the load to permit true remote sensing and avoid trace drops.
2	ADJ/GND	Adjust or Ground. On the FAN1582, this pin forms the feedback to determine the output voltage. On the FAN1582-1.5 and -2.5, connect this pin to ground.
3	VOUT	Output Voltage. This pin and the tab are output.
4	VCNTL	Control Voltage. This pin draws small-signal power to control the FAN1582 circuitry. Connect to a voltage higher than VIN, as shown in the applications circuits.
5	VIN	Input Voltage.

Internal Block Diagram

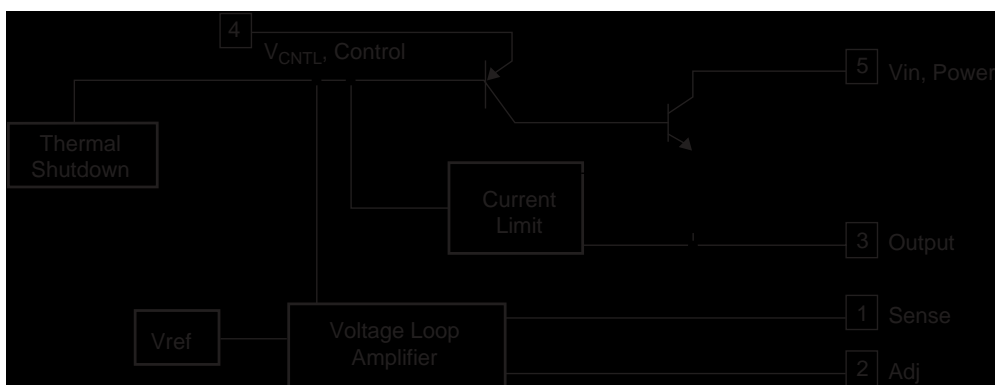

Absolute Maximum Ratings

Parameter	Min.	Max.	Unit
V_{IN}		7	V
V_{CNTL}		13.2	V
Operating Junction Temperature Range	0	125	°C
Lead Temperature (Soldering, 10 sec.)		300	°C
Storage Temperature Range	-65	150	°C

Electrical Characteristics

$T_J=25^\circ\text{C}$, $V_{OUT} = V_S$, $V_{ADJ} = 0\text{V}$ unless otherwise specified.

The • denotes specifications which apply over the specified operating temperature range.

Parameter	Conditions	Min.	Typ.	Max.	Units
Reference Voltage ³	$V_{IN} = 2.0\text{V}$, $V_{CNTL} = 2.75\text{V}$, $I_{OUT} = 10\text{mA}$	1.243	1.250	1.257	V
Reference Voltage ³	$2.05\text{V} \leq V_{IN} \leq 5.5\text{V}$, $2.7\text{V} \leq V_{CNTL} \leq 12\text{V}$, $10\text{mA} \leq I_{OUT} \leq 3\text{A}$	• 1.237	1.250	1.263	V
Adjustable Output Voltage	$3\text{V} \leq V_{IN} \leq 7\text{V}$ (function of V_{out}), $10\text{mA} \leq I_{OUT} \leq 3\text{A}$	• V_{ref}	1.5	5.7	V
Output Voltage ⁴	$3\text{V} \leq V_{IN} \leq 7\text{V}$, $10\text{mA} \leq I_{OUT} \leq 3\text{A}$	• 1.47	1.5	1.53	V
Output Voltage ⁵	$5.1\text{V} \leq V_{IN} \leq 7\text{V}$, $10\text{mA} \leq I_{OUT} \leq 3\text{A}$	• 2.474	2.5	2.526	V
Line Regulation ^{1,2}	$1.75\text{V} \leq V_{IN} \leq 5.5\text{V}$, $2.5\text{V} \leq V_{CNTL} \leq 12\text{V}$, $I_{OUT} = 10\text{mA}$	•	1	3	mV
Load Regulation ^{1,2}	$V_{IN} = 2.1\text{V}$, $V_{CNTL} = 2.75\text{V}$, $10\text{mA} \leq I_{OUT} \leq 3\text{A}$	•	1	5	mV
Dropout Voltage Minimum ($V_{CNTL}-V_{OUT}$)	$V_{IN} = 2.05\text{V}$, $\Delta V_{REF} = 1\%$, $I_{OUT} = 3\text{A}$	•	1.05	1.18	V
Dropout Voltage Minimum ($V_{IN}-V_{OUT}$)	$V_{CNTL} = 2.75\text{V}$, $\Delta V_{REF} = 1\%$, $I_{OUT} = 3\text{A}$		0.4	0.5	V
Dropout Voltage Minimum V_{IN}	$V_{CNTL} = 2.75\text{V}$, $\Delta V_{REF} = 1\%$, $I_{OUT} = 3\text{A}$	•	0.5	0.6	V
Current Limit	$V_{IN} = 2.05\text{V}$, $V_{CNTL} = 2.75\text{V}$	• 3.1			A
Control Pin Current	$V_{IN} = 2.05\text{V}$, $V_{CNTL} = 2.75\text{V}$, $I_{OUT} = 10\text{mA}$	•	2	6	mA
Adjust Pin Current ³	$V_{IN} = 2.05\text{V}$, $V_{CNTL} = 2.75\text{V}$	•	50	120	μA
Minimum Load Current	$V_{IN} = 3.3\text{V}$, $V_{CNTL} = 5\text{V}$	•	5.0	10	mA
Ripple Rejection	$V_{IN} = 3.75\text{V}$, $V_{CNTL} = 3.75\text{V}$, $f = 120\text{Hz}$, $C_{OUT} = 22\mu\text{F}$ Tantalum, $I_{OUT} = 1.5\text{A}$	60	80		dB
Thermal Resistance, Junction to Case	TO-263/TO-252 SPAK		3 2		°C/W
Thermal Regulation	$T_A = 25^\circ\text{C}$, 30ms pulse		0.002	0.02	%/W
Thermal Shutdown			150		°C

Notes:

- See thermal regulation specifications for changes in output voltage due to heating effects. Load and line regulation are measured at a constant junction temperature by low duty cycle pulse testing.
- Line and load regulation are guaranteed up to the maximum power dissipation (18W). Power dissipation is determined by input/output differential and the output current. Guaranteed maximum output power will not be available over the full input/output voltage range.
- FAN1582 only.
- FAN1582-1.5 only.
- FAN1582-2.5 only.

Typical Performance Characteristics

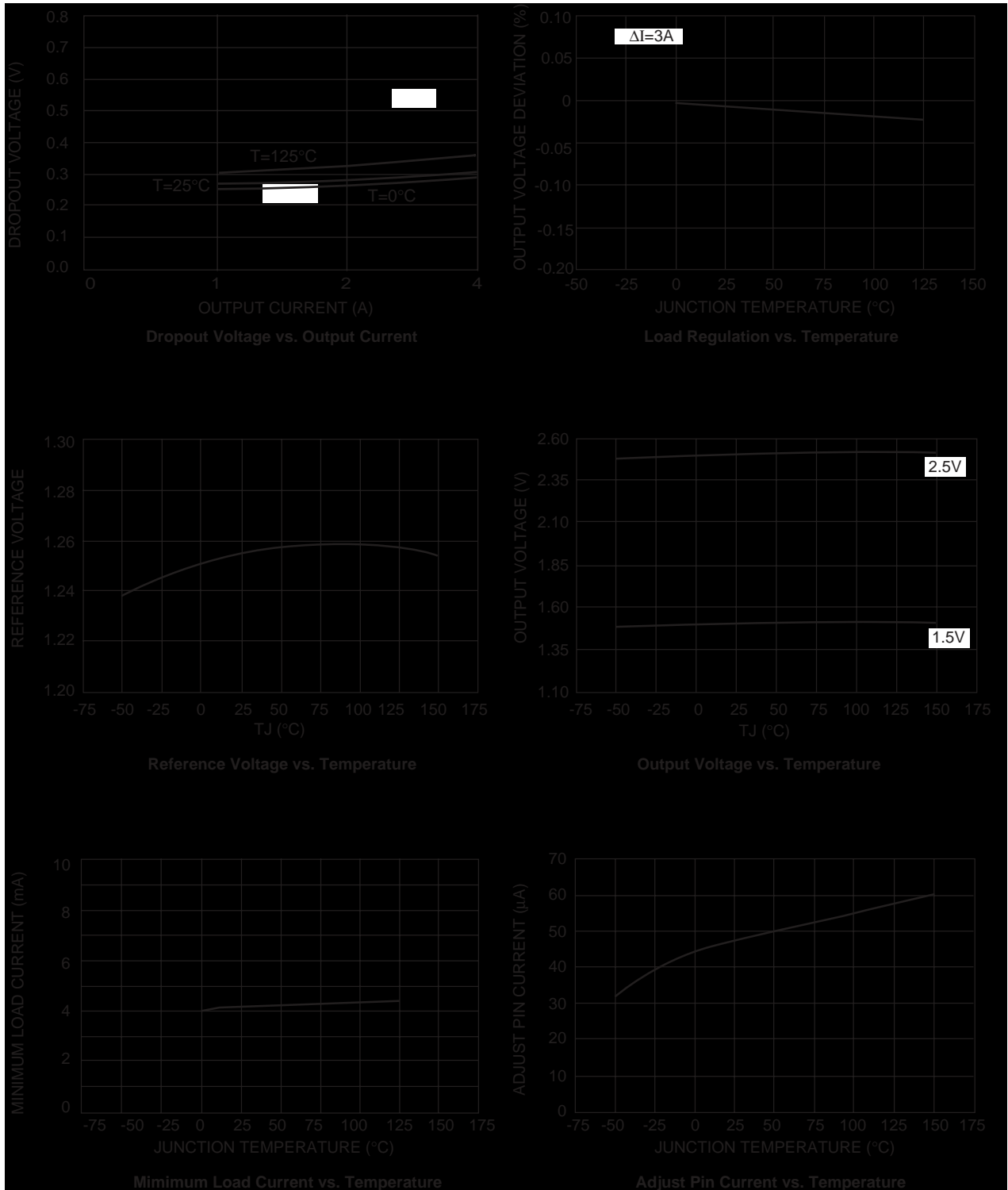

Typical Performance Characteristics (continued)

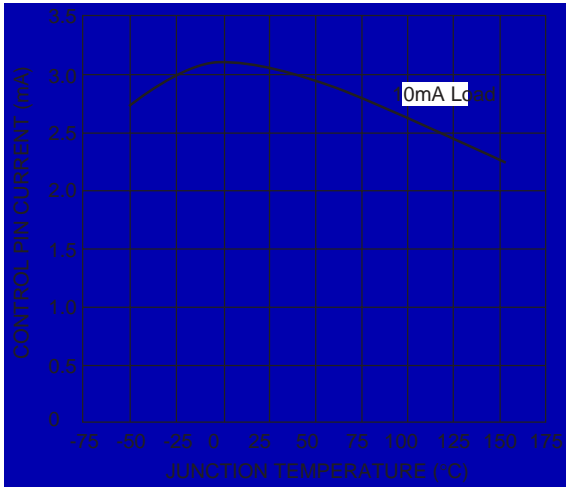

Control Pin Current vs. Temperature

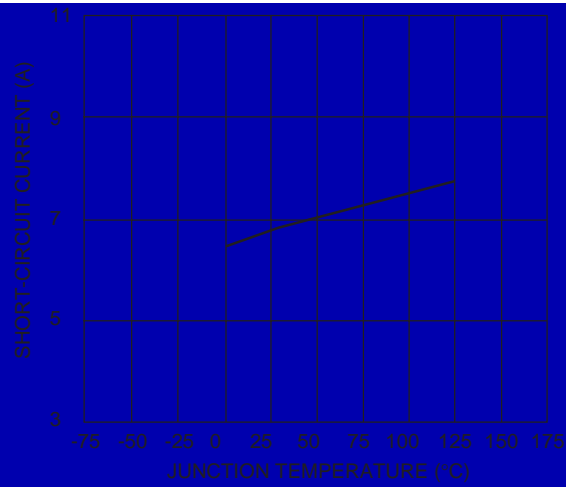

Short-Circuit Current vs. Temperature

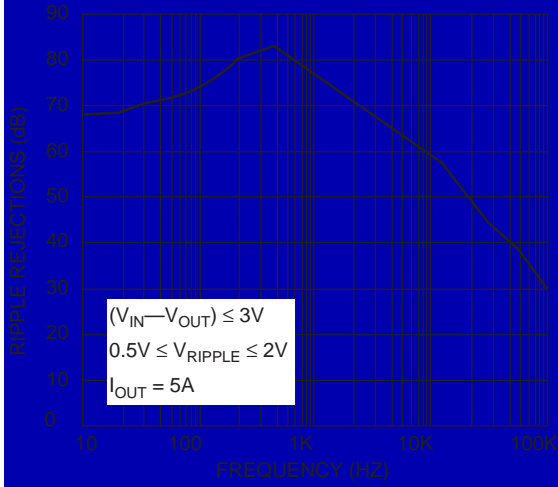

Ripple Rejection vs. Frequency

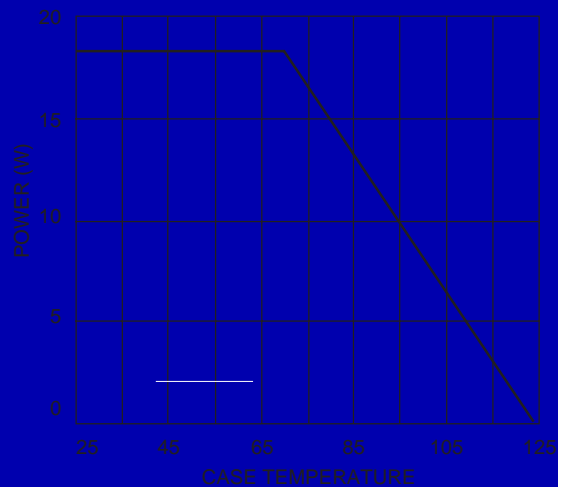

Maximum Power Dissipation

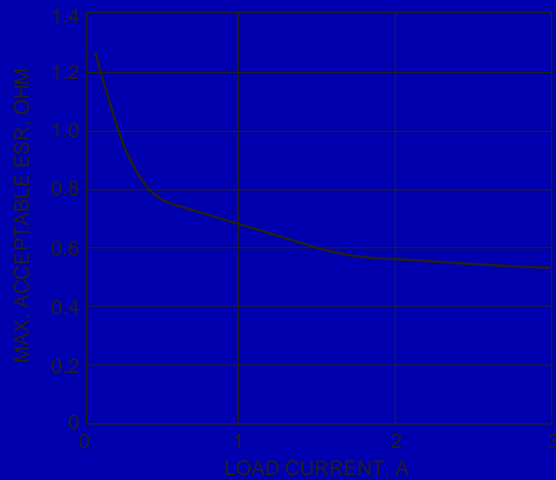

FAN1582 Stability

General

The FAN1582, FAN1582-1.5, and FAN1582-2.5 are three-terminal regulators optimized for GTL+ V_{TT} termination and logic applications. These devices are short-circuit protected, and offer thermal shutdown to turn off the regulator when the junction temperature exceeds about 150°C. The FAN1582 series provides low dropout voltage and fast transient response. Frequency compensation uses capacitors with low ESR while still maintaining stability. This is critical in addressing the needs of low voltage high speed microprocessor buses like GTL+.

V_{IN} and V_{CNTL} Functions

The FAN1582 utilizes a dual supply approach to maximize efficiency. The collector of the power device is brought out to the V_{IN} pin to minimize internal power dissipation under high current loads. V_{CNTL} provides power for the control circuitry and the drive for the output NPN transistor. V_{CNTL} should be at least 1.2 V higher than the output voltage. Special care was taken to ensure there are no supply-sequencing problems. The output voltage will not turn on until both supplies are operating. If the control voltage comes up first, the output current will be typically limited to about 3.0 mA until the power input voltage comes up. If the power input voltage comes up first the output will not turn on at all until the control voltage comes up. The output can never come up unregulated.

The FAN1582 can also be used as a single supply device with the control and power inputs tied together. In this mode, the dropout is determined by the minimum control voltage.

Stability

The FAN1582 series requires an output capacitor as a part of the frequency compensation. It is recommended to use a 22 μ F solid tantalum or a 100 μ F aluminum electrolytic on the output to ensure stability. The frequency compensation of these devices optimizes the frequency response with low ESR capacitors. In general, it is suggested to use capacitors with an ESR of $<0.3\Omega$. It is also recommended to use bypass capacitors such as a 22 μ F tantalum or a 100 μ F aluminum on the adjust pin of the FAN1582 for low ripple and fast transient response. When these bypassing capacitors are not used at the adjust pin, smaller values of output capacitors provide equally good results. A graph showing stability of output capacitance ESR vs load current can be found under Typical Performance Characteristics.

Protection Diodes

In normal operation, the FAN1582 series does not require any protection diodes. For the FAN1582, internal resistors limit internal current paths on the adjust pin. Therefore, even with bypass capacitors on the adjust pin, no protection diode is needed to ensure device safety under short-circuit conditions.

A protection diode between the input and output pins is usually not needed. An internal diode between the input and the

output pins on the FAN1582 series can handle microsecond surge currents of 50A to 100A. Even with large value output capacitors it is difficult to obtain those values of surge currents in normal operation. Only with large values of output capacitance, such as 1000 μ F to 5000 μ F, and with the input pin instantaneously shorted to ground can damage occur. A crowbar circuit at the input can generate those levels of current; a diode from output to input is then recommended, as shown in Figure 1. Usually, normal power supply cycling or system “hot plugging and unplugging” will not generate current large enough to do any damage.

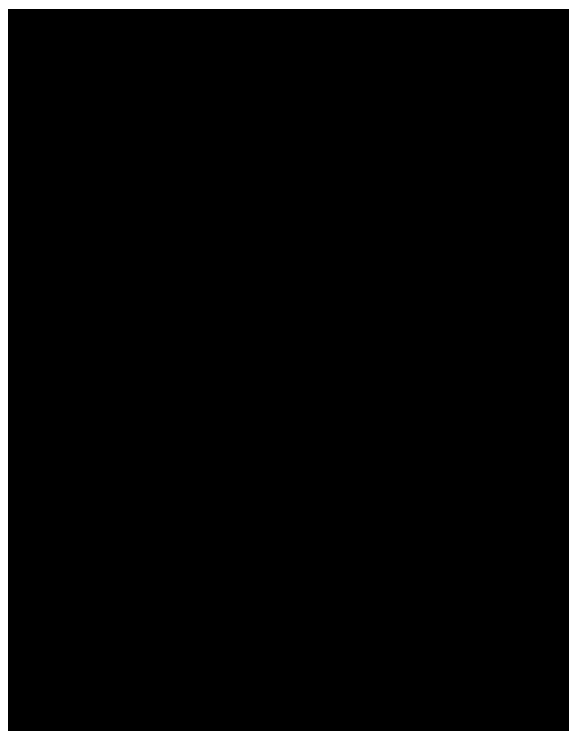

Figure 1. Optional Protection Diode

Ripple Rejection

In applications that require improved ripple rejection, a bypass capacitor from the adjust pin of the FAN1582 to ground reduces the output ripple by the ratio of $V_{OUT}/1.25V$. The impedance of the adjust pin capacitor at the ripple frequency should be less than the value of $R1$ (typically in the range of 100 Ω to 120 Ω) in the feedback divider network in Figure 1. Therefore, the value of the required adjust pin capacitor is a function of the input ripple frequency. For example, if $R1$ equals 100 Ω and the ripple frequency equals 120Hz, the adjust pin capacitor should be 22 μ F. At 10kHz, only 0.22 μ F is needed.

Output Voltage

The FAN1582 regulator develops a 1.25V reference voltage between the output pin and the adjust pin (see Figure 2). Placing a resistor $R1$ between these two terminals causes a constant current to flow through $R1$ and down through $R2$ to set the overall output voltage. Normally, this current is the specified minimum load current of 10mA.

The current out of the adjust pin adds to the current from R1 and is typically 50µA. Its output voltage contribution is small and only needs consideration when a very precise output voltage setting is required.

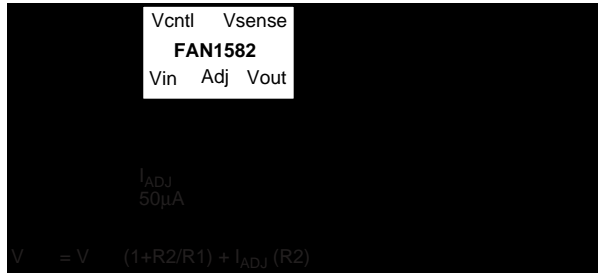

Figure 2. Basic Regulator Circuit

Load Regulation

The FAN1582 family provides true remote sensing, eliminating output voltage errors due to trace resistance. To utilize remote sensing, connect the VSENSE pin directly to the load, rather than at the VOUT pin. If the load is more than 1" away from the FAN1582, it may be necessary to increase the load capacitance to ensure stability.

Thermal Considerations

The FAN1582 series protect themselves under overload conditions with internal power and thermal limiting circuitry. However, for normal continuous load conditions, do not exceed maximum junction temperature ratings. It is important to consider all sources of thermal resistance from junction-to-ambient. These sources include the junction-to-case resistance, the case-to-heat sink interface resistance, and the heat sink resistance. Thermal resistance specifications have been developed to more accurately reflect device temperature and ensure safe operating temperatures. The electrical characteristics section provides a separate thermal resistance and

maximum junction temperature for both the control circuitry and the power transistor. Calculate the maximum junction temperature for both sections to ensure that both thermal limits are met.

For example, look at using an FAN1582M-1.5 to generate 3A @ 1.5V ± 2% from a 3.3V source (3.2V to 3.6V).

Assumptions:

- $V_{in} = 3.6V$ worst case
- $V_{OUT} = 1.47V$ worst case
- $I_{OUT} = 3A$ continuous
- $T_A = 70^\circ C$
- $\Theta_{Case-to-Ambient} = 5^\circ C/W$ (assuming both a heatsink and a thermally conductive material)

The power dissipation in this application is:

$$P_D = (V_{IN} - V_{OUT}) \cdot (I_{OUT}) = (3.6 - 1.47) \cdot (3) = 6.39W$$

From the specification table,

$$T_J = T_A + (P_D) \cdot (\Theta_{Case-to-Ambient} + \Theta_{JC}) = 70 + (6.39) \cdot (5 + 3) = 121^\circ C$$

The junction temperature is below the maximum rating.

Junction-to-case thermal resistance is specified from the IC junction to the bottom of the case directly below the die. This is the lowest resistance path for heat flow. Proper mounting ensures the best thermal flow from this area of the package to the heat sink. Use of a thermally conductive material at the case-to-heat sink interface is recommended. Use a thermally conductive spacer if the case of the device must be electrically isolated and include its contribution to the total thermal resistance.

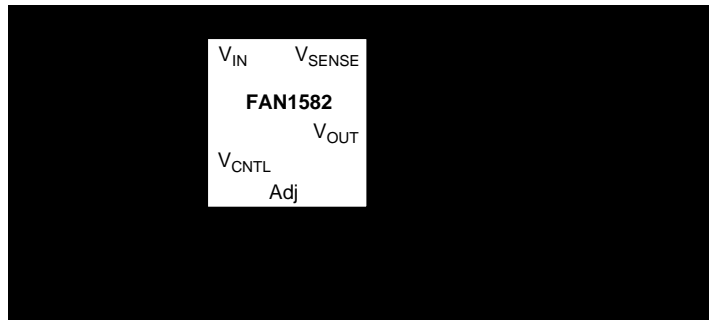

Figure 3. Application Circuit (FAN1582)

Table 1. Bill of Materials for Application Circuit for the FAN1582

Item	Quantity	Manufacturer	Part Number	Description
C1, C3	2	Xicon	L10V10	10 μ F, 10V Aluminum
C2	1	Xicon	L10V100	100 μ F, 10V Aluminum
C4	1	Any		1 μ F Ceramic
R1	1	Generic		124 Ω , 1%
R2	1	Generic		86.6 Ω , 1%
U1	1	Fairchild	FAN1582P	3A Regulator

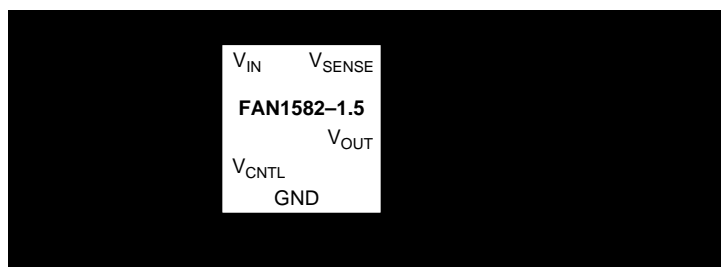

Figure 4. Application Circuit (FAN1582-1.5)

Table 2. Bill of Materials for Application Circuit for the FAN1582-1.5

Item	Quantity	Manufacturer	Part Number	Description
C1	1	Xicon	L10V10	10 μ F, 10V Aluminum
C2	1	Any		1 μ F Ceramic
C3	1	Xicon	L10V100	100 μ F, 10V Aluminum
U1	1	Fairchild	FAN1582P-1.5	3A Regulator

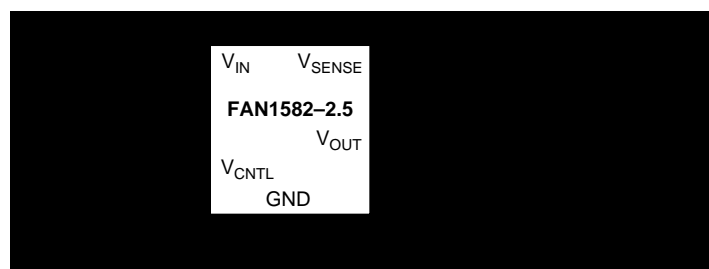

Figure 5. Application Circuit (FAN1582-2.5)

Table 3. Bill of Materials for Application Circuit for the FAN1582-2.5

Item	Quantity	Manufacturer	Part Number	Description
C1	1	Xicon	L10V10	10 μ F, 10V Aluminum
C2	1	Any		1 μ F Ceramic
C3	1	Xicon	L10V100	100 μ F, 10V Aluminum
U1	1	Fairchild	FAN1582P-2.5	3A Regulator

Mechanical Dimensions

5-Lead TO-263 Package

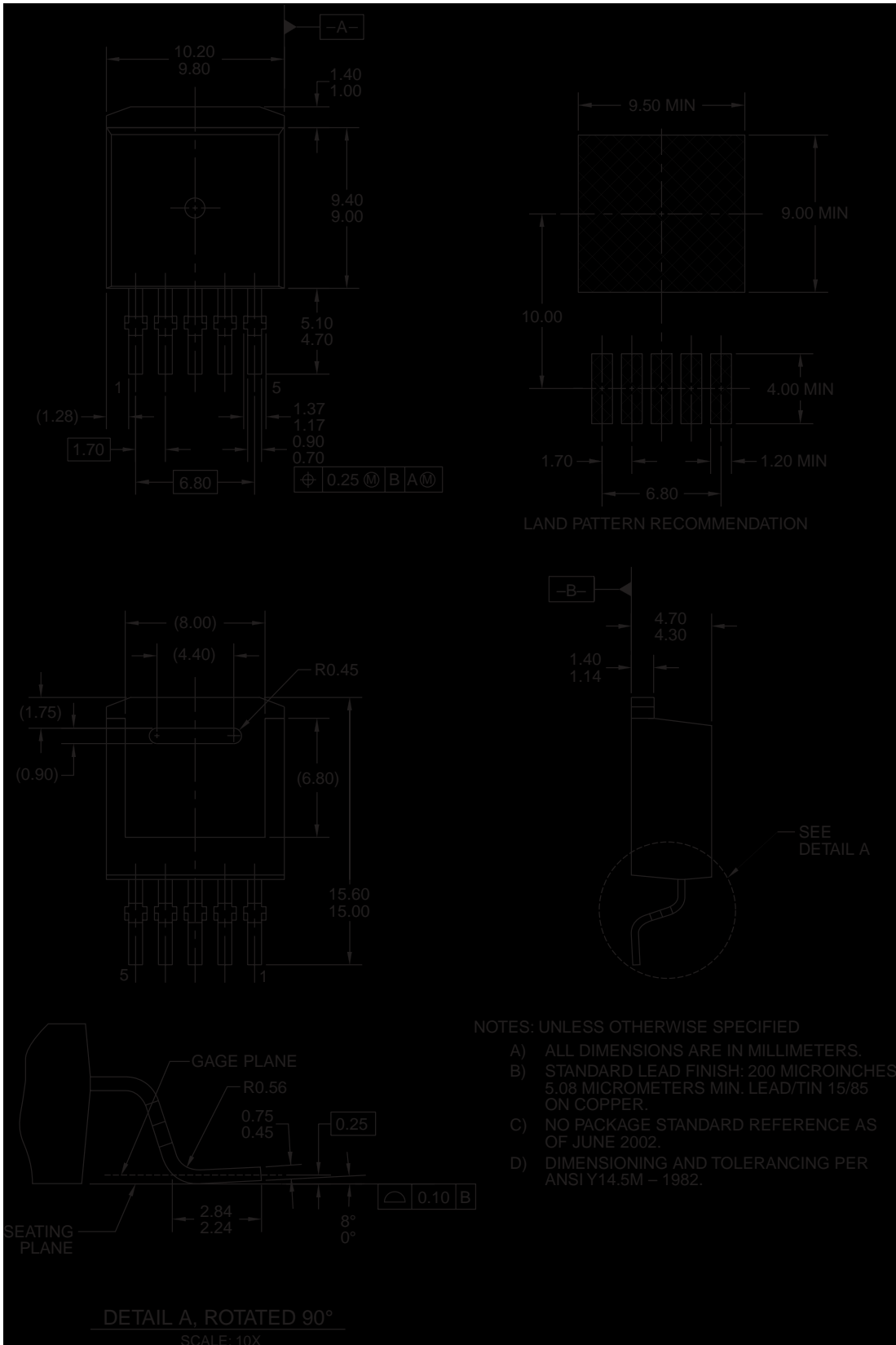

Mechanical Dimensions (continued)

5-Lead TO-252 Package

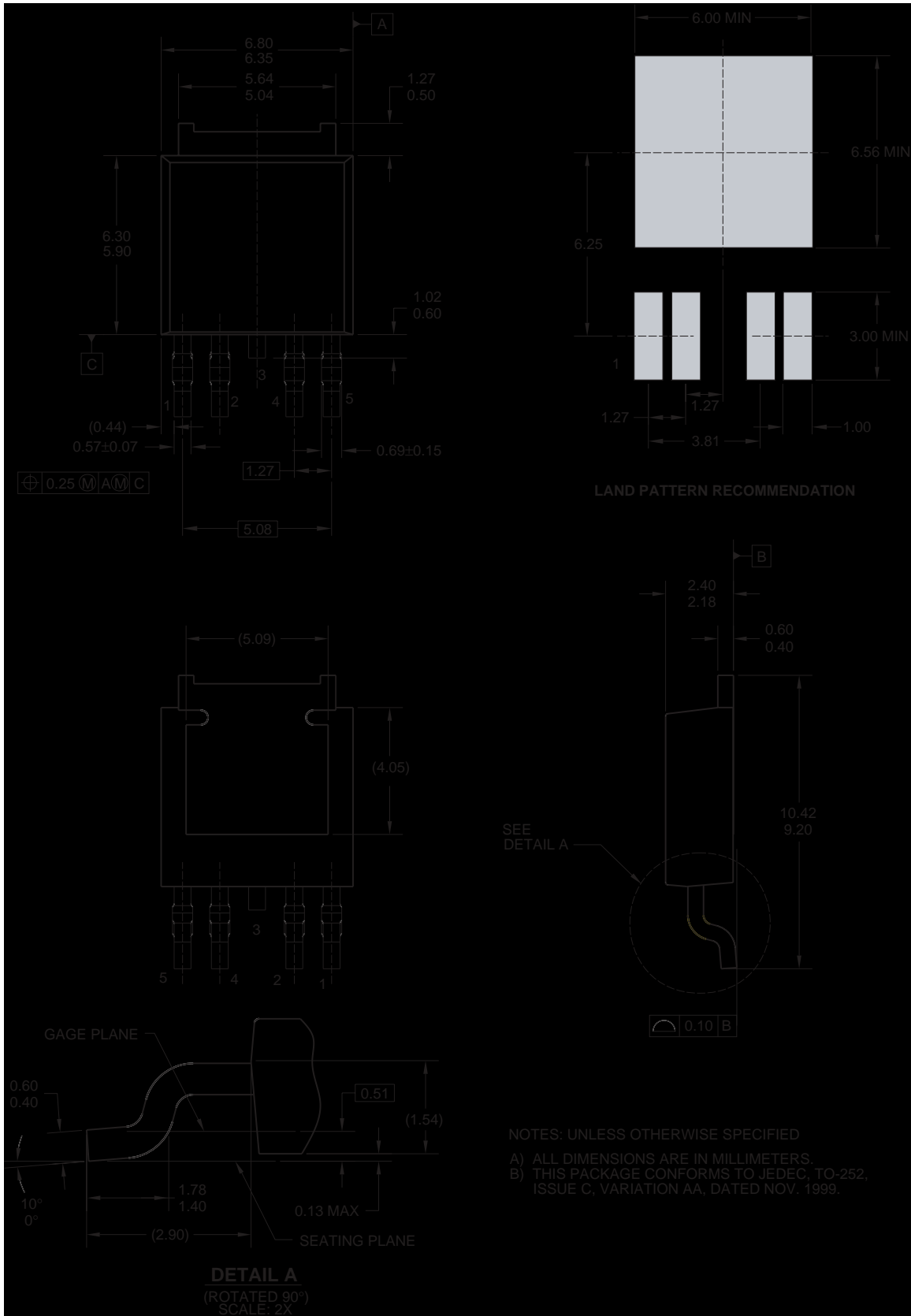

NOTES: UNLESS OTHERWISE SPECIFIED
 A) ALL DIMENSIONS ARE IN MILLIMETERS.
 B) THIS PACKAGE CONFORMS TO JEDEC, TO-252, ISSUE C, VARIATION AA, DATED NOV. 1999.

Ordering Information

Product Number	Package
FAN1582MX	TO-263 in Tape and Reel
FAN1582DX	TO-252 DPAK in Tape and Reel
FAN1582M15X	TO-263 in Tape and Reel
FAN1582D15X	TO-252 DPAK in Tape and Reel
FAN1582M25X	TO-263 in Tape and Reel
FAN1582D25X	TO-252 DPAK in Tape and Reel

LIFE SUPPORT POLICY

FAIRCHILD'S PRODUCTS ARE NOT AUTHORIZED FOR USE AS CRITICAL COMPONENTS IN LIFE SUPPORT DEVICES OR SYSTEMS WITHOUT THE EXPRESS WRITTEN APPROVAL OF THE PRESIDENT OF FAIRCHILD SEMICONDUCTOR CORPORATION. As used herein:

1. Life support devices or systems are devices or systems which, (a) are intended for surgical implant into the body, or (b) support or sustain life, and (c) whose failure to perform when properly used in accordance with instructions for use provided in the labeling, can be reasonably expected to result in a significant injury of the user.
2. A critical component in any component of a life support device or system whose failure to perform can be reasonably expected to cause the failure of the life support device or system, or to affect its safety or effectiveness.