

μP Supervisory Circuit

Features

- User-Adjustable Low/High Thresholds with 615mV Internal Reference
- Low Current (1.5μA typ)
- Single Low-Battery Outputs
- Push-Pull $\overline{\text{LBO}}$, Open-Drain $\overline{\text{LBO}}$ and Open-Drain LBO options
- 90ms Minimum LBO Timeout Period
- Immune to Short Battery Voltage Transients
- -40°C to + 85°C Operating Temperature Range

Application

- Monitoring lithiumion (Li+) cells or multicell alkaline/ NiCd/ NiMH power supplies.

Description

The PT7M7433/34/35 are single-level battery monitors with internal hysteresis. These devices are offered with single low-battery output indicators which can be used to indicate three battery conditions: good (operate system in normal mode), weak (operate system in low-power mode), or empty (disable the system).

The PT7M7433/34/35 are user-adjustable threshold voltages permitting the user to select the hysteresis range and consequently the sensitivity of the system to noise. A wide hysteresis range also prevents chattering that can result due to battery recovery after load removal.

Pin Configuration

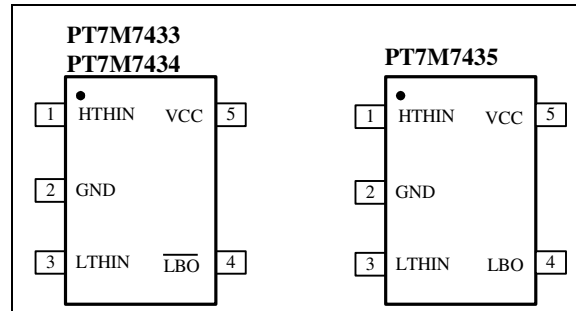

Pin Description

Pin	Name	Type	Description
1	HTHIN	I	HTH Threshold Monitor Input. A resistor-divider network sets the high threshold associated with $\overline{\text{LBO}}$ /LBO.
2	GND	P	Ground
3	LTHIN	I	LTH Threshold Monitor Input. A resistor-divider network sets the low threshold associated with $\overline{\text{LBO}}$ /LBO.
4	$\overline{\text{LBO}}$ /LBO	O	Low-Battery Output. $\overline{\text{LBO}}$ /LBO is asserted when LTHIN drops below V_{LTHIN} , and remains asserted for at least 90ms HTHIN rises above V_{HTHIN} . Push-pull output for PT7M7433. Open drain output for PT7M7434/35.
5	VCC	P	Supply Voltage. Device power supply for adjustable threshold versions.

Block Diagram

PT7M7433/34/35 Block Diagram

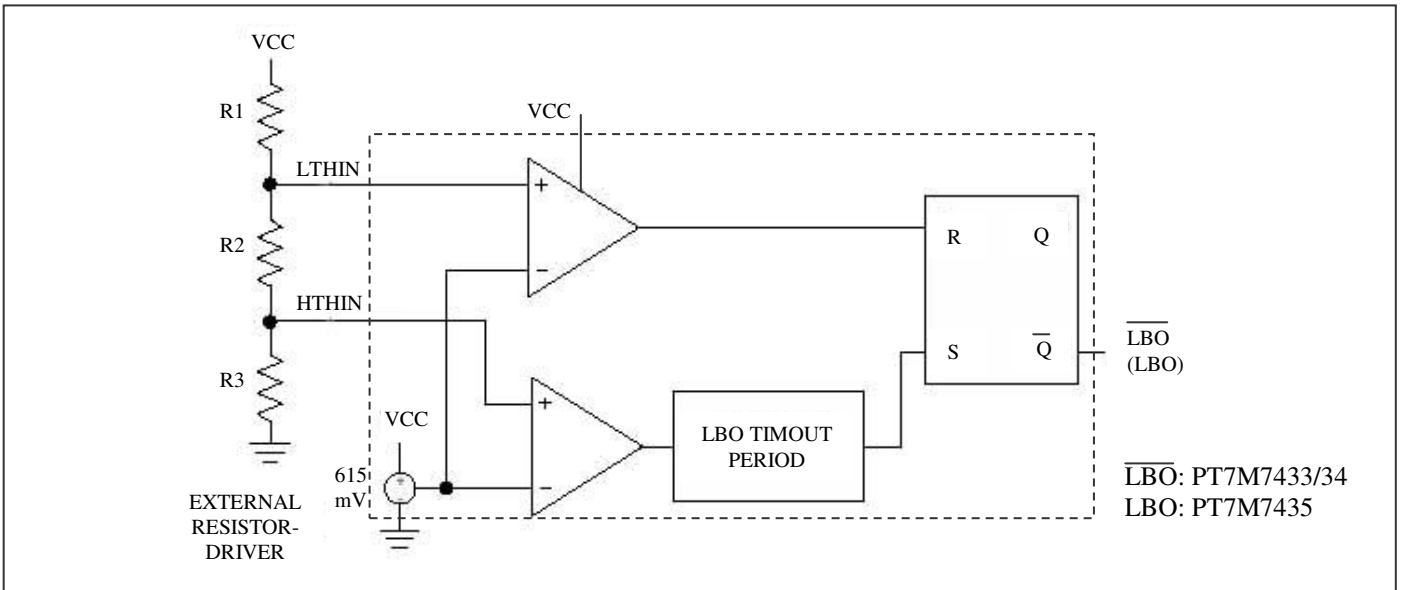

Maximum Ratings

Storage Temperature	-65°C to +150°C
Ambient Temperature with Power Applied.....	-40°C to +85°C
Supply Voltage to Ground Potential (Vcc to GND)	-0.3V to +7.0V
DC Input Voltage (All inputs except Vcc and GND).....	-0.3V to VCC+0.3V
DC Output Current (All outputs)	20mA
Power Dissipation	320mW
	(Depend on package)

Note:

Stresses greater than those listed under MAXIMUM RATINGS may cause permanent damage to the device. This is a stress rating only and functional operation of the device at these or any other conditions above those indicated in the operational sections of this specification is not implied. Exposure to absolute maximum rating conditions for extended periods may affect reliability.

DC Electrical Characteristics

($V_{CC}=1.8V$ to $5.5V$, $T_A=-40\sim 85^{\circ}C$, unless otherwise noted. Typical values are at $T_A = +25^{\circ}C$)

Description	Symbol	Test Conditions	Min	Typ	Max	Unit
Operating Voltage Range	V_{CC}	$T_A = -40\sim 85^{\circ}C$	1.8	-	5.5	V
V_{CC} Supply Current	I_{CC}	$V_{CC} = 3.7V$, no load $T_A = -40\sim 85^{\circ}C$	-	1.5	2.5	μA
Output High Voltage (Push-Pull only)	V_{OH}	$V_{CC} \geq 1.6V$, $I_{source} = 200\mu A$	$0.8 \times V_{CC}$	-	-	V
		$V_{CC} \geq 2.7V$, $I_{source} = 500\mu A$	$0.8 \times V_{CC}$	-	-	
		$V_{CC} \geq 4.5V$, $I_{source} = 800\mu A$	$0.8 \times V_{CC}$	-	-	
Output Low Voltage	V_{OL}	$V_{CC} \geq 1.6V$, $I_{sink} = 100\mu A$	-	-	0.3	V
		$V_{CC} \geq 2.7V$, $I_{sink} = 1.2mA$	-	-	0.3	
		$V_{CC} \geq 4.5V$, $I_{sink} = 3.2mA$	-	-	0.4	
Open-Drain Output Leakage Current	I_{LKG}	-	-	-	1	μA
Input Leakage Current	I_{LKG}	V_{HTHIN} or $V_{LTHIN} > 400mV$	-	-	20	nA

User-adjustable Thresholds (PT7M7433/34/35)

HTHIN Threshold(Note)	V_{HTHIN}	HTHIN rising, LBO is deasserted when HTHIN rises above 615mV.	$T_A = 25^{\circ}C$	-1.5	-	+1.5	%
			$T_A = -30\sim 70^{\circ}C$	-2.5	-	-2.5	%
LTHIN Threshold(Note)	V_{LTHIN}	LTHIN falling, LBO is asserted when LTHIN falls below 615mV.	$T_A = 25^{\circ}C$	-1.5	-	+1.5	%
			$T_A = -30\sim 70^{\circ}C$	-2.5	-	-2.5	%

Note: Typical value is 615mV. Minimum and Maximum value is percentage of typical value.

AC Electrical Characteristics

Fig 1. PT7M7433/34/35 timing diagram

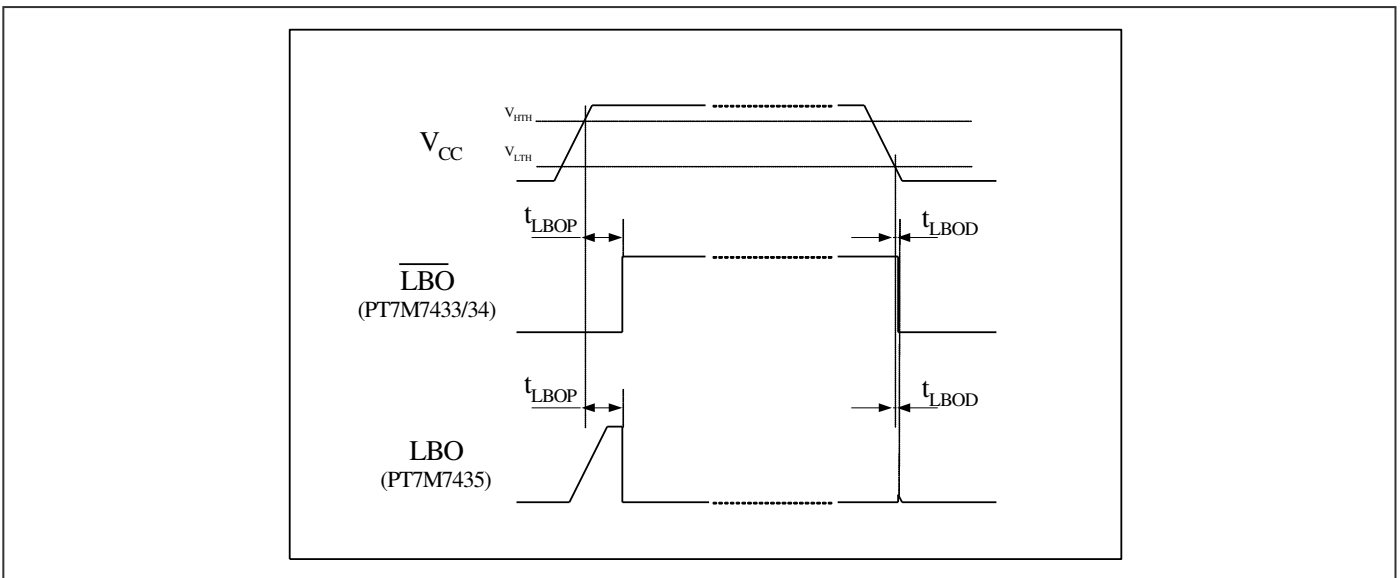

($V_{CC}=1.8V$ to $5.5V$, $T_A=-40\sim 85^{\circ}C$, unless otherwise noted. Typical values are at $T_A = +25^{\circ}C$)

Symbol	Description	Test Conditions	Min	Typ	Max	Unit
t_{LBOP}	Timeout period	-	90	200	350	ms
t_{LBOD}	Delay	-	-	70	-	μs

Function Description

The PT7M7433/34/35 are available with user adjustable monitoring.

The user sets the threshold voltages for the PT7M7433/34/35, which permit the user to select the hysteresis range, and consequently the sensitivity of the system to noise. A wide hysteresis range prevents chattering that can result during battery recovery or load removal. The PT7M7433/34/35 have single low-battery outputs.

The PT7M7433/34/35 combine a 615mV reference with two comparators, logic, and timing circuitry to provide the user with information about the charge state of the power-supply batteries. The PT7M7433/34/35 monitor separate high-voltage and low-voltage thresholds to determine battery status. The output can be used to signal when the battery is charged, when the battery is low, and when the battery is empty. PT7M7433/34/35 are also available with thresholds determined using an external resistor-divider (see Application information *Resistor-Value Selection*). The adjustable versions can monitor down to 0.62V, making them suitable for monitoring single-cell alkaline, NiMH, and NiCd applications ($V_{CC} \geq 1.8V$).

When the power-supply voltage drops below the specified low threshold, the low-battery output asserts (see *Low-Battery Output*). When the voltage rises above the specified high threshold following a 90ms (min) time-out period, the low-battery output is deasserted (see *Threshold Monitoring*). This ensures the supply voltage has stabilized before power-converter or microprocessor activity is enabled.

Low-Battery Output

The low-battery outputs are available in active-low (LBO, push-pull and open-drain) and action-high (LBO open-drain) configurations. Push-pull outputs are referenced to V_{CC} (for adjustable threshold versions).

The open-drain devices can be pulled to a voltage independent of V_{CC} or BATT, up to 5.5V. This allows the device to monitor and operate from direct battery voltage while interfacing to higher voltage microprocessors.

The PT7M7433/34/35 single-output voltage monitors provide a single low-battery output, LBO/LBO. The PT7M7433/34 adjustable-threshold parts assert LBO/LBO when the LTHIN input drops below the V_{LTHIN} threshold (615mV).

Threshold Monitoring

The PT7M7433/34/35 HTHIN and LTHIN inputs are high-impedance inputs to comparators. An external resistor divider network is required between the monitored voltage, HTHIN, LTHIN, and GND to select the desired thresholds (see Application information *Resistor-Value Selection*). The PT7M7433/34/35 single-output voltage monitors assert LBO /LBO when LTHIN drops below the internal LTHIN reference (615mV). LBO/LBO is deasserted when HTHIN rises above the internal HTHIN reference level (615mV) for at least 90ms (see AC Electrical Characteristics: Fig 1).

Hysteresis

Hysteresis increases the comparator's noise margin by increasing the upper threshold or decreasing the lower threshold (see blow). The hysteresis prevents the output from oscillating (chattering) when V_{CC} is near the low-battery threshold. This is especially important for applications where the load on the battery creates significant fluctuations in battery voltages.

Adjustable Hysteresis (PT7M7433/34/35)

Block diagram shows the correct connections for the external resistor-dividers. To adjust the low-battery threshold and hysteresis connect resistor R1 between V_{CC} and LTHIN, resistor R2 between LTHIN and HTHIN, and R3 between HTHIN and GND. The hysteresis for the PT7M7433/34/35 is determined by an external resistor-divider network (see Application information *Resistor-Value Selection*).

Fig 2. PT7M7433/34/35 adjustable hysteresis

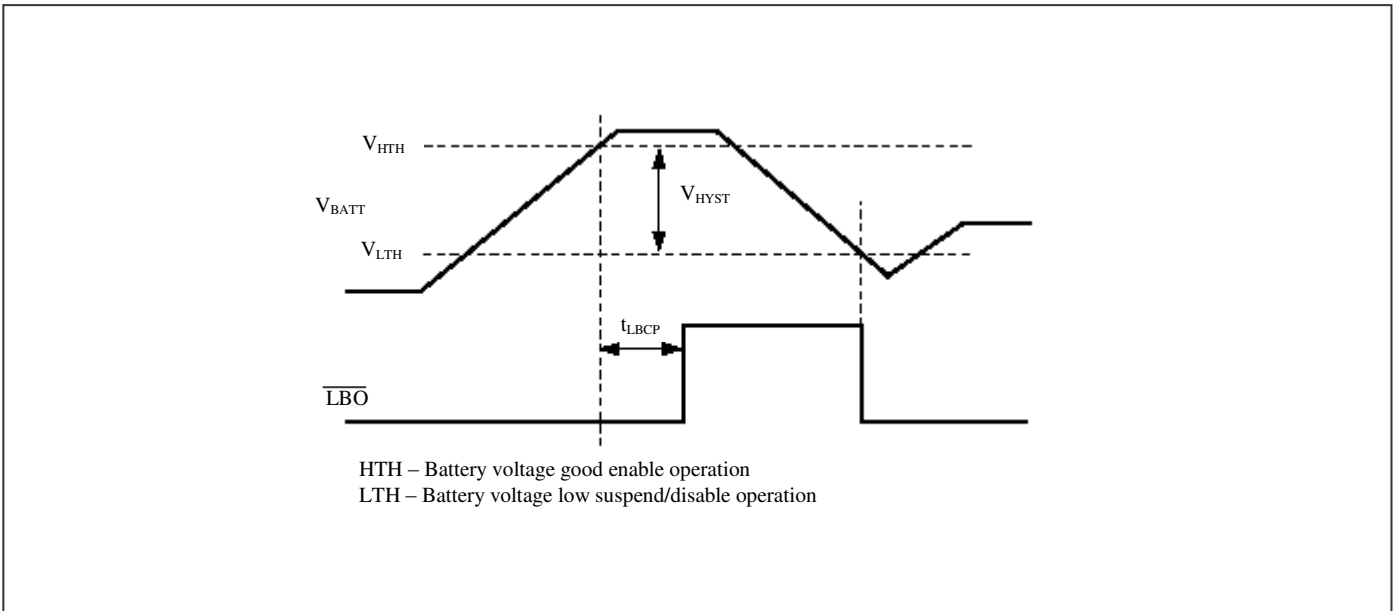

Application Information

Resistor-Value Selection (Programming the Adjustable Thresholds)

$$V_{REF} = V_{LTHIN} = V_{HTHIN} = 615\text{mV}$$

$$V_{TRIPLOW} = V_{LTH} = V_{REF} \left(\frac{R1 + R2 + R3}{R2 + R3} \right)$$

$$V_{TRIPHIGH} = V_{HTL} = V_{REF} \left(\frac{R1 + R2 + R3}{R3} \right)$$

$$R_{TOTAL} = R1 + R2 + R3$$

Use the following steps to determine values for R1, R2, and R3 of Functional Block Diagram.

- 1) Choose a value for R_{TOTAL} . Because the PT7M7433/34/35 have very high input impedance, R_{TOTAL} can be up to $5\text{M}\Omega$.
- 2) Calculate R3 based on R_{TOTAL} and the desired upper trip point:

$$R3 = \frac{V_{REF} \times R_{TOTAL}}{V_{TRIPHIGH}} = \frac{615\text{mV} \times R_{TOTAL}}{V_{TRIPHIGH}}$$

- 3) Calculate R2 based on R_{TOTAL} , R3, and the desired lower trip point:

$$R2 = \frac{615\text{mV} \times R_{TOTAL}}{V_{TRIPLOW}} - R3$$

- 4) Calculate R1 based on R_{TOTAL} , R3, and R2:

$$R1 = R_{TOTAL} - R2 - R3$$

Mechanical Information

TAE (Lead free and Green SOT23-5)

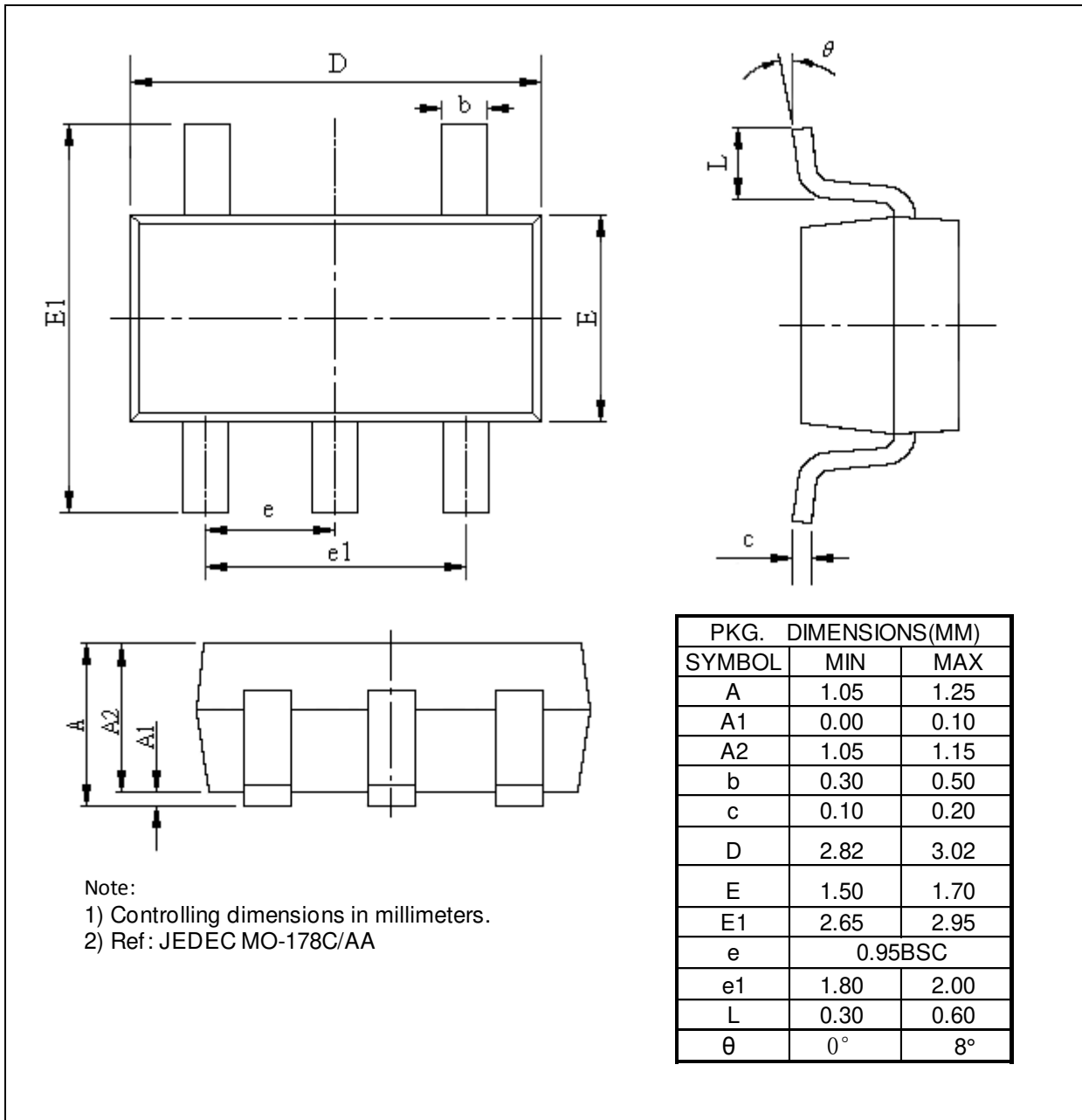

Ordering Information

Part Number	Package Code	Package	Marking Code
PT7M7433TAE	TA	lead-free and Green SOT23-5	MM
PT7M7434TAE	TA	lead-free and Green SOT23-5	MN
PT7M7435TAE	TA	lead-free and Green SOT23-5	MO

Note:

- E = Pb-free and Green
- Adding X Suffix= Tape/Reel

Table 1. Function comparison of PT7M7433/34/35

Item	Part No.	Output					Threshold	
		Open-Drain		Push-Pull	Single	Dual	Factory fixed	User adjustable
		Active high	Active low	Active low				
1	PT7M7433	-	-	√	√	-	-	√
2	PT7M7434	-	√	-	√	-	-	√
3	PT7M7435	√	-	-	√	-	-	√

SOT-23 Package Top Marking Instruction

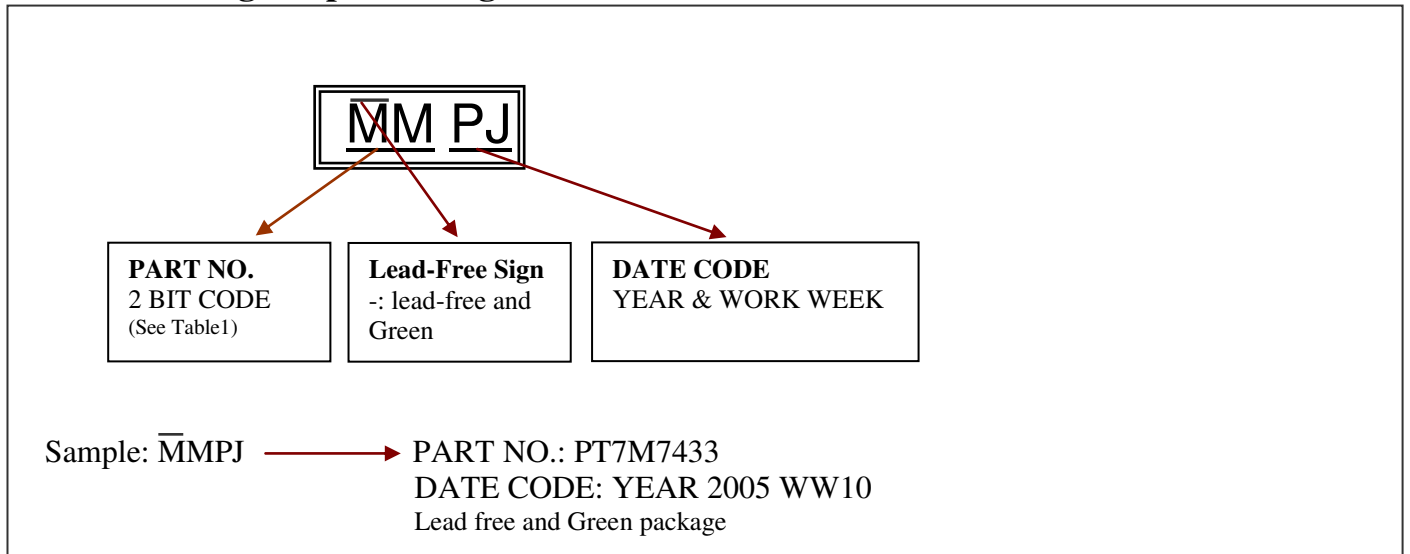

1. Package Type: SOT-23
2. Package Code: TA
3. 2005-Year Code: P
4. Work Week Code: WW7-G WW8-H WW9-I WW10-J WW11-K WW12-L
 WW13-M WW14-N WW15-O WW16-P WW17-Q
5. Font Style: HELVETICA or ARIAL
6. Max Characters Per Line (Only 1 line): 4
7. Max Characters Height: 0.8 mm
8. Min Characters Height: 0.6 mm
9. Max Characters Width: 0.6 mm
10. Mark Placement: Center

Pericom Semiconductor Corporation • 1-800-435-2336 • www.pericom.com

Pericom reserves the right to make changes to its products or specifications at any time, without notice, in order to improve design or performance and to supply the best possible product. Pericom does not assume any responsibility for use of any circuitry described other than the circuitry embodied in Pericom product. The company makes no representations that circuitry described herein is free from patent infringement or other rights, of Pericom.