

© - TE Connectivity. All Rights Reserved.

REVISIONS				
P	LTR	DESCRIPTION	DATE	APVD
	G2	ECN-22-150900	27APR2022	RK CSD

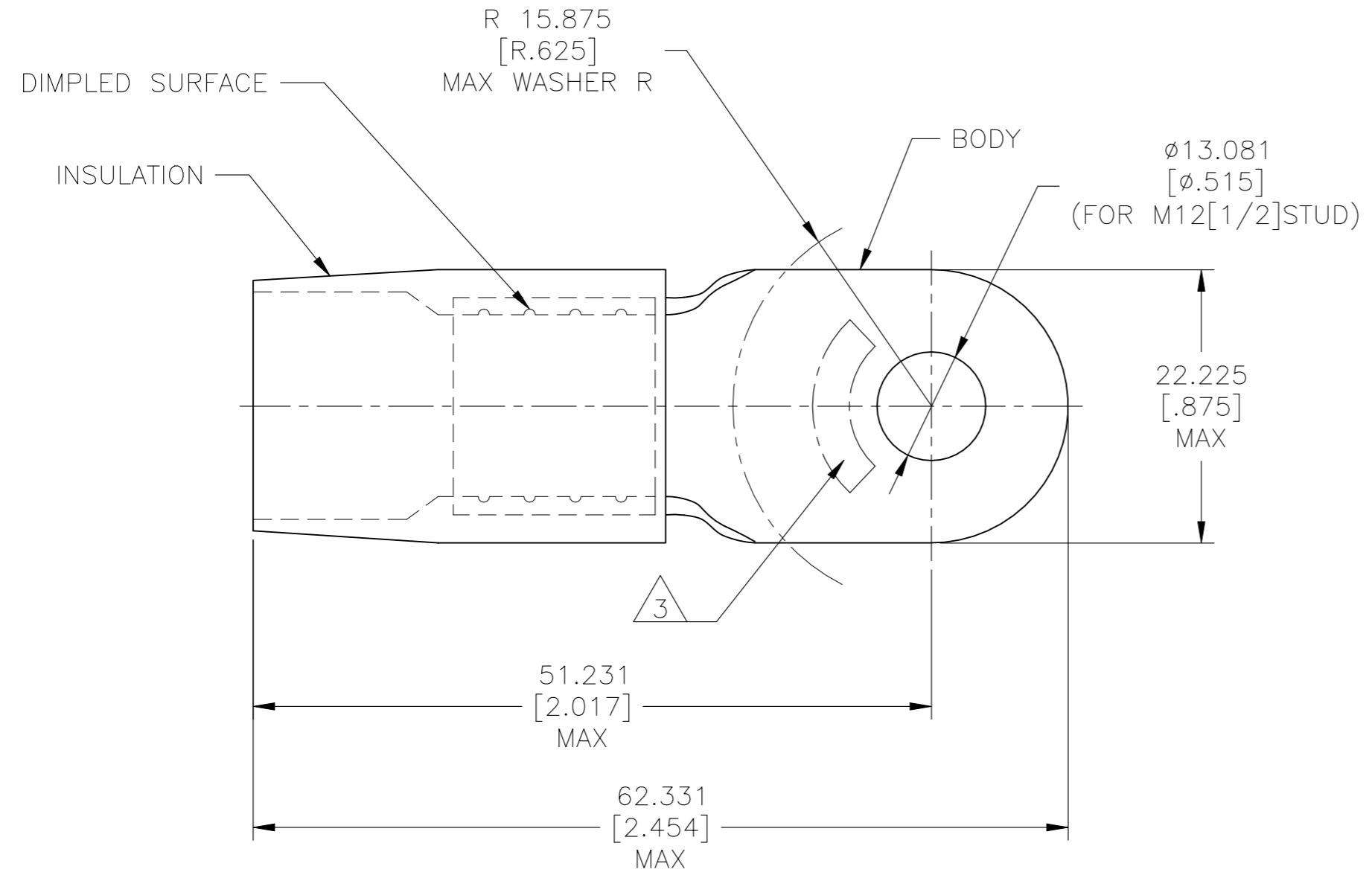
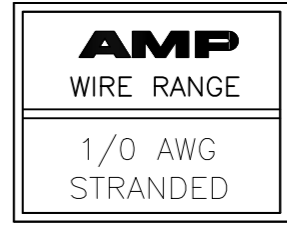

- 1 BODY MATERIAL THK 1.778±0.051[.070±.002]
- 2 FOR Ø14.732[Ø.580] MAX WIRE INS.
- △ 3 STAMP AMP 1/0 W* APPROX AS SHOWN.

50	LOOSE PC	324058
QTY	PACKAGE TYPE	PART NO

AMP INCORPORATED CUSTOMER SERVICE SYSTEMS		MAX RECOMMENDED OPERATING TEMPERATURE: 105°C[221°F]	THIS DRAWING IS A CONTROLLED DOCUMENT.		DWN S.S. GOULDEN 6-21-93	TE Connectivity NAME TERMINAL, RING TONGUE, TERMINYL WIRE SIZE: 1/0 AWG					
FOR ADDITIONAL PRODUCT INFORMATION OR COPIES OF DRAWINGS AND TECHNICAL DOCUMENTS	PRODUCT INFORMATION CENTER 1-800-522-6752	VOLTAGE RATING: -	DIMENSIONS: mm [INCHES]	TOLERANCES UNLESS OTHERWISE SPECIFIED:	CHK R. HERSEY 6-21-93				APVD B. BARE 6-21-93	SIZE	CAGE CODE
FOR APPLICATION TOOLING INFORMATION	TOOLING ASSISTANCE CENTER 1-800-722-1111	CIRCULAR MIL AREA: 42.4-60.6mm² [83,700-119,500] STRANDED		0 PLC ± - 1 PLC ± - 2 PLC ± - 3 PLC ± 0.127[.005] 4 PLC ± - ANGLES ± -	PRODUCT SPEC -	APPLICATION SPEC -	DRAWING NO	RESTRICTED TO			
FOR ORDER ENTRY	1-800-526-5142	THIS DRAWING IS A CONTROLLED DOCUMENT FOR AMP INCORPORATED. IT IS SUBJECT TO CHANGE AND THE CONTROLLING ENGINEERING ORGANIZATION SHOULD BE CONTACTED FOR THE LATEST REVISION.		MATERIAL BODY: COPPER PER ASTM B-152 INSULATION: NYLON ASTM D4066 TYPE I	FINISH BODY: TIN PLATE PER ASTM B545 INSULATION: COLOR-BLUE	WEIGHT -	A3	00779	C-324058		
CUSTOMER DRAWING						SCALE	NTS	SHEET	1 OF 1	REV	G2