

MGate™ 5111 Series

1-port Modbus/PROFINET/EtherNet/IP to PROFIBUS slave gateways



- > Supports PROFIBUS DP V0 slave
- > Supports Modbus RTU/ASCII/TCP master or slave
- > Supports EtherNet/IP adapter or PROFINET IO device
- > Built-in traffic monitoring/diagnostics/status monitoring and fault protection
- > Built-in Ethernet cascading for easy wiring
- > Redundant dual DC power inputs and relay output supported
- > microSD card for configuration backup/duplication, and event log
- > Serial port with 2 kV built-in isolation protection
- > -40 to 75°C wide operating temperature models available
- > Security features based on IEC-62443



Introduction

MGate 5111 industrial Ethernet gateways convert data between the Modbus RTU/ASCII/TCP, EtherNet/IP, PROFINET, and PROFIBUS protocols. All models are protected by a rugged metal housing, are DIN-rail mountable, and offer built-in serial isolation.

Modbus is one of the most widely used industrial communication protocols, and EtherNet/IP, PROFINET, and PROFIBUS are commonly used in factory automation and process automation. The MGate 5111 supports both Modbus RTU/ASCII/TCP master and slave modes, so that you can easily connect your Modbus device to PROFIBUS PLCs or DCSs, such as Siemens PLCs.

For System integration, the MGate 5111 can connect to EtherNet/IP PLC/SCADA systems, such as Rockwell Automation PLCs, to PROFIBUS PLC/DCS systems, or between a new Siemens PLC system that supports PROFINET to an existing PROFIBUS system. The MGate 5111 gateways are designed for easy configuration and quick maintenance. A handy web console can be used to implement remote maintenance tasks, and the configuration wizard UI lets you quickly set up your gateway. A comprehensive collection of troubleshooting tools reduce configuration time and system downtime. The rugged design is suitable for industrial applications such as factory automation, power, oil & gas, water and wastewater, and other process automation industries.

Easy Configuration

The MGate 5111 series gateway has a friendly user interface that lets you quickly set up protocol conversion routines for most applications, doing away with what were often time-consuming tasks in which users had to implement detailed parameter configurations one by one. With Quick Setup, you can easily access protocol conversion modes and finish the configuration in a few steps. The MGate 5111 supports a

web console and Telnet console for remote maintenance. Encryption communication functions, including HTTPS and SSH, are supported to provide better network security. In addition, system monitoring functions are provided to record network connections and system log events.

Variety of Maintenance Functions

The MGate 5111 supports Protocol Diagnose and Traffic Monitor for easy troubleshooting, especially during the installation stage. Communication issues caused by incorrect software parameters, like slave IDs and register addresses, or incorrect command configurations, can be fished out with Protocol Diagnose and Traffic Monitor, which let you capture and check data to easily identify root causes.

MGate 5111 gateways also support status monitoring and fault protection functions. The status monitoring function notifies a PLC/DCS/SCADA system when a Modbus device gets disconnected or does not respond, in which case the process PLC/DCS gets the status of each end device and then issues alarms to notify operators. When a PROFIBUS cable gets disconnected, the fault protection function executes actions on end devices identified by a pre-defined value set by the user.

Specifications

Industrial Protocols

Protocols: PROFIBUS, Modbus RTU/ASCII/TCP, PROFINET, EtherNet/IP

Protocol Conversion:

- Modbus RTU/ASCII (Master/Slave) to PROFIBUS slave
- Modbus TCP (Client/Server) to PROFIBUS slave
- EtherNet/IP (Adapter) to PROFIBUS slave
- PROFINET (IO Device) to PROFIBUS slave

Ethernet Interface

Protocols: Modbus TCP (Client/Server), PROFINET (IO device), EtherNet/IP (Adapter)

Number of Ports: 2 (1 IP address, supports Ethernet cascading)

Speed: 10/100 Mbps, Auto MDI/MDIX

Connector: 8-pin RJ45

Magnetic Isolation Protection: 1.5 kV (built-in)

PROFIBUS Interface

Protocol: PROFIBUS DP-V0 Slave

Number of Ports: 1

Data Rate: 9600 bps to 12 Mbps

Connector: DB9 female

Isolation: 2 kV (built-in)

Rotary Switch: PROFIBUS address 0-99 (address 100-125 supported through software configuration)

Modbus Serial Interface

Protocols: Modbus RTU/ASCII (Master/Slave)

Number of Ports: 1

Serial Standards: RS-232/422/485, software selectable

Connectors: DB9 male

Pull High/Low Resistor for RS-485: 1 k Ω , 150 k Ω

Terminator for RS-485: 120 Ω

Isolation: 2 kV (built-in)

Modbus Serial Communication Parameters

Data Bits: 8

Stop Bits: 1, 2

Parity: None, Even, Odd, Space, Mark

Flow Control: RTS/CTS, RTS Toggle (RS-232 only)

Baudrate: 50 bps to 921.6 kbps

Modbus Serial Signals

RS-232: Tx+, Rx+, RTS, CTS, DTR, DSR, DCD, GND

RS-422: Tx+, Tx-, Rx+, Rx-, GND

RS-485-4w: Tx+, Tx-, Rx+, Rx-, GND

RS-485-2w: Data+, Data-, GND

Modbus TCP Interface

Protocols: Modbus TCP client/server

Functions Supported: 1, 2, 3, 4, 5, 6, 15, 16, 23

Max. Number of Commands: 128

Max. Number of Connections:

- MGate as Modbus TCP Client: 32 connections
- MGate as Modbus TCP Server: 16 connections

Max. Total I/O Data Size:

Input: 2048 bytes

Output: 2048 bytes

EtherNet/IP Interface

Class: Adapter

CIP Objects Supported:

Identity, Message Router, Assembly, Connection Manager, TCP/IP interface, Ethernet link, Port

Max. Number of Connections:

- MGate as Adapter:
 - 1 connection for read/write
 - 1 connection for read-only

Max. Total I/O Data Size:

Input: 496 bytes

Output: 496 bytes

PROFINET Interface

Protocol: PROFINET RT IO Device

Max. Total I/O Data Size:

Input: 512 bytes

Output: 512 bytes

Maximum No. of Connections: 1 master connection

Software

Configuration Options: Web console, Serial console

Utility: Device Search Utility (DSU) for Windows 95, 98, ME, NT, 2000, Windows XP, Server 2003, Vista, Server 2008 (x86/x64), Windows Server 2008 R2, Windows 7/8/8.1/10 (x86/x64), Windows Server 2012 (x64), Windows 2012 R2

Network Protocols: TCP/IP, UDP, HTTP, HTTPS, SMTP, NTP, DNS, DHCP Client, SNMP (v1, v2c, v3), MIB-II, ARP, Telnet, SSH

Support: MXview, MXconfig

Physical Characteristics

Housing: Metal, IP30

Weight: 589 g (1.30 lb)

Dimensions: 45.8 x 105 x 134 mm (1.8 x 4.13 x 5.28 in)

Storage Card Slot: 1 microSD (SDHC) card slot; supports up to 32 GB

Relay Alarm Circuit: 3-pin circuit with current carrying capacity of 2 A @ 30 VDC

Environmental Limits

Operating Temperature:

Standard Models: 0 to 60°C (32 to 140°F)

Wide Temp. Models: -40 to 75°C (-40 to 167°F)

Storage Temperature: -40 to 85°C (-40 to 185°F)

Ambient Relative Humidity: 5 to 95% (non-condensing)

Vibration: IEC 60068-2-6, IEC 60068-2-64

Shock: IEC 60068-2-27

Drop: IEC 60068-2-32

Power Requirements

Input Voltage: 12 to 48 VDC

Input Current: 416 mA max.

Power Connector: Terminal block

Standards and Certifications

Safety: EN 60950-1(LVD), UL 61010-2-201

Hazardous Location: Class I Division 2, ATEX, IECEx

EMC: EN 61000-6-2/6-4

EMI: CISPR 22, FCC Part 15B Class A

EMS:

IEC 61000-4-2 ESD: Contact: 8 kV; Air: 15 kV

IEC 61000-4-3 RS: 80 MHz to 1 GHz: 10 V/m

IEC 61000-4-4 EFT: Power: 4 kV; Signal: 4 kV

IEC 61000-4-5 Surge: Power 2 kV; Signal: 2 kV

IEC 61000-4-6 CS: 150 kHz to 80 MHz: 10 V/m

IEC 61000-4-8 PFMF: 30 A/m

Reliability

Alarm Functions: Relay, email, SNMP trap

Alert Tools: Built-in buzzer

MTBF (mean time between failures)

Time: 718,131 hrs

Standard: Telcordia SR332

Warranty

Warranty Period: 5 years

Details: See www.moxa.com/warranty

Dimensions

Unit: mm (inch)

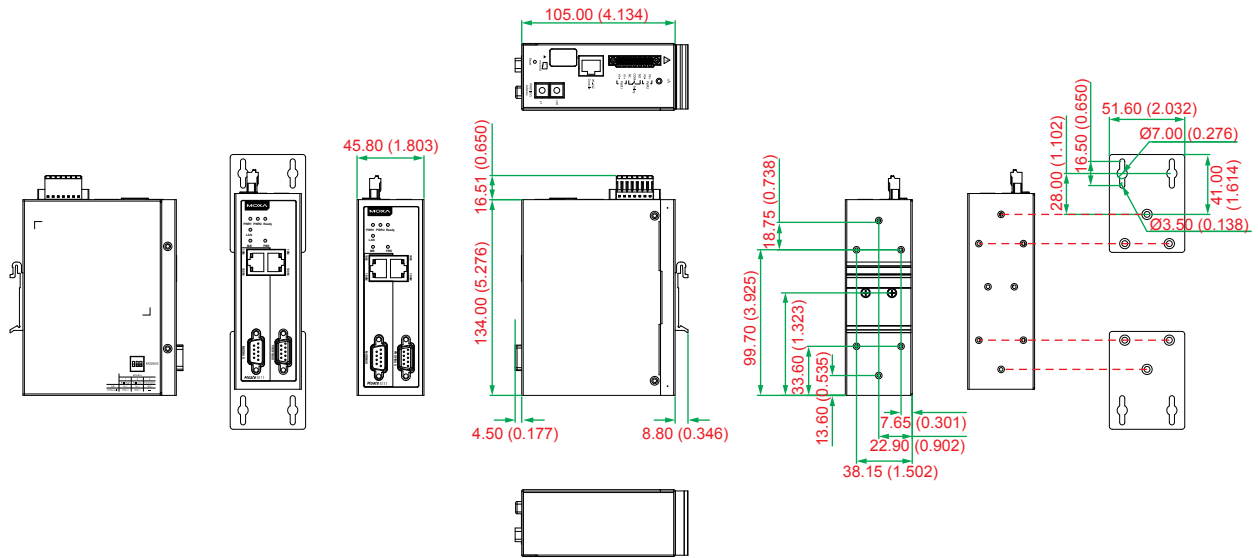

Ordering Information

Available Models

MGate 5111: Modbus/PROFINET/EtherNet/IP to PROFIBUS slave gateway, 0 to 60°C operating temperature

MGate 5111-T: Modbus/PROFINET/EtherNet/IP to PROFIBUS slave gateway, -40 to 75°C operating temperature

Optional Accessories (can be purchased separately)

WK-51-01: Wall-mounting kit, 2 plates with 6 screws

Mini DB9F-to-TB: DB9 female to terminal block connector

Package Checklist

- 1 MGate 5111 gateway
- Quick installation guide (printed)
- Warranty card