

NOTES:

- FOR WAVESOLDERING (SOLDER BATH TEMPERATURE 265°C FOR 8 SEC. AND SOLDER PREHEAT 150°C FOR 180 SEC.)
- IP RATING: IP 67
- SEALED TO WITHSTAND PRESSURE UP TO 1,45 PSI FOR 30 MINUTES AFTER HIGH TEMPERATURE EXPOSURE
- METAL SHELL:  
ZINC DIE CAST; min. 50µin NICKEL PLATING over COPPER
- INSULATORS: PBT GF UL 94 V-0, BLACK
- O-RING: SILICONE PER ASTM D2000 70 SHORE A
- SEALING COMPOUND: EPOXY RESIN UL 94 V-0; BLACK
- CONTACTS: COPPER ALLOY  
PLATING (SEE PART NO):  
 PLEASE ADD 1 for 30µin HARD GOLD over min. 50µin NICKEL  
 PLEASE ADD 3 for 8µin HARD GOLD over min. 50µin NICKEL
- METAL BRACKETS: ZINC DIE CAST;  
300µin COPPER/40-120µin NICKEL/120-200µin TIN
- WASHERS: COPPER ALLOY; 80µin NICKEL
- HEXLOCKING SCREWS: STAINLESS STEEL
- FIXING-PLATE: PBT GF UL 94 V-0; BLACK
- PCB-SNAPS: COPPER ALLOY; min. 200µin TIN over 80µin NICKEL  
PCB-HOLE: Ø3.1±0.1; PCB THICKNESS 1.6mm
- P.C.B. HOLE DRILLINGS and RECOMMENDED PANEL CUT-OUT ON SHEET 2
- RECOMMENDED TORQUE FOR MOUNTING SCREW  
35Ncm (3.1 in.LB) / max.67Ncm (6 in.LB)
- CONNECTOR IS PART MARKED: 15-00224 CONEC ABC

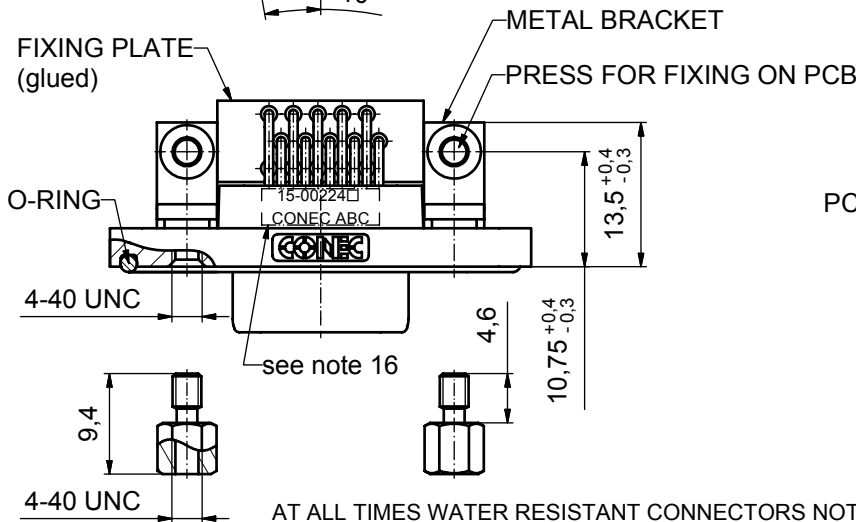

AT ALL TIMES WATER RESISTANT CONNECTORS NOT IN USE SHOULD BE COVERED WITH A CONEC WATER RESISTANT CAP OR WATER TIGHT HOOD.

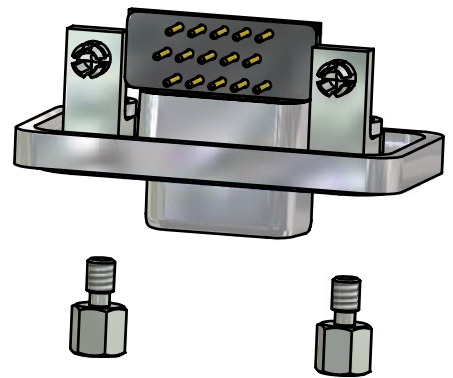
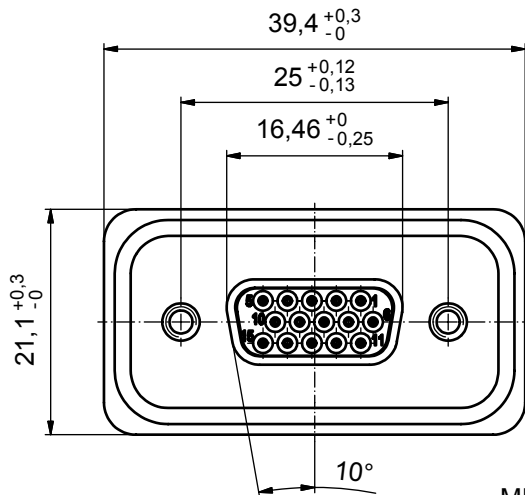
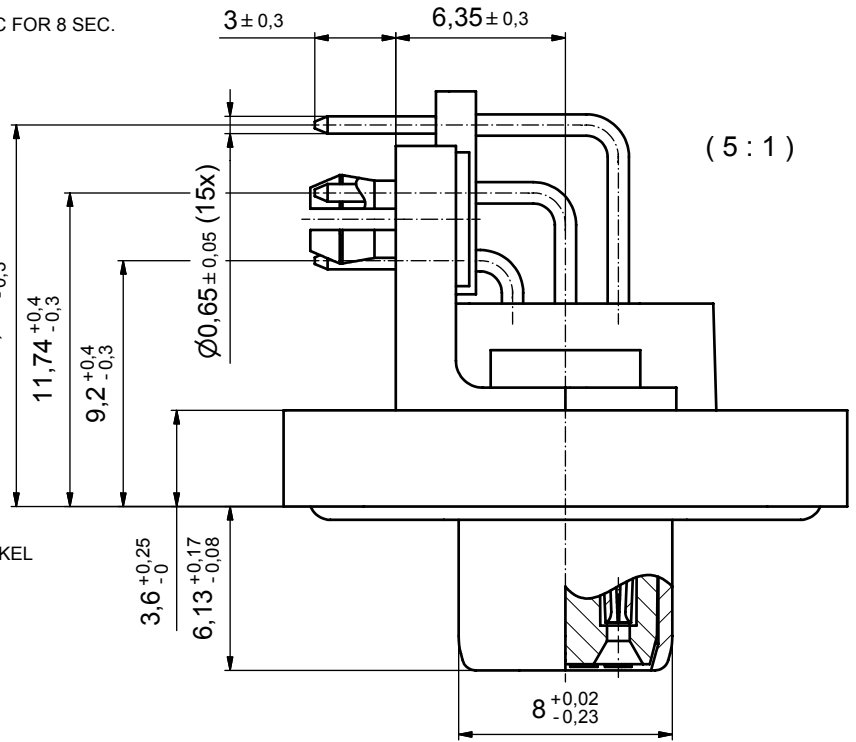

APPROVAL # FREIGABE # DEBLOCAGE # AUTORIZACION # APPROVAL	
CUSTOMER APPROVAL DATE:	
NAME:	TITLE:
COMPANY NAME:	
APPROVAL # FREIGABE # DEBLOCAGE # AUTORIZACION # APPROVAL	

tolerance				dim. in mm	scale: 2:1 (5:1)		
material:					see notes		
date				name		title:	
drawn 23.11.09				Schmidt		D-SUB HD FEMALE 90° 15pos. SOLDER PIN ANGLED metal bracket, fixing plate, hexlocking screw, snap	
appd. 27.11.09				Fischer			
norm				d-old			
a Origin				CONEC®		dwg no: Inventor 10	
rev. description date name						15K1A500	
						part no: 15-00224 (see note 8)	

# P.C.B. HOLE DRILLINGS

(P.C.B. TOP SIDE)

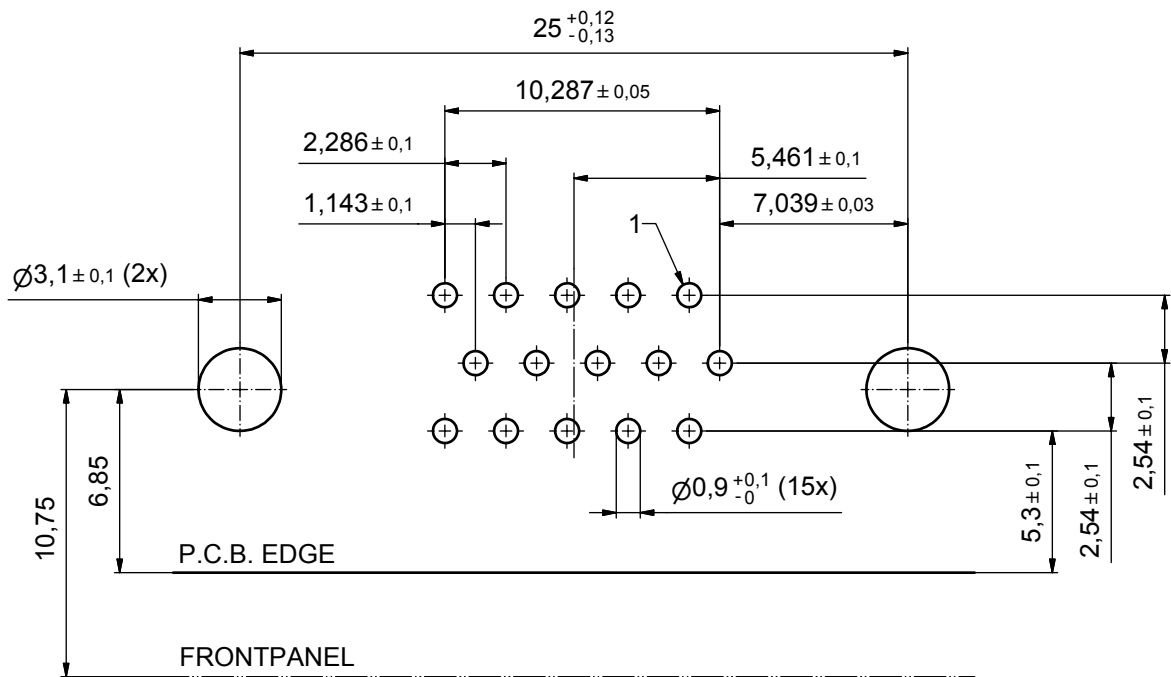

## RECOMMENDED PANEL CUT-OUT

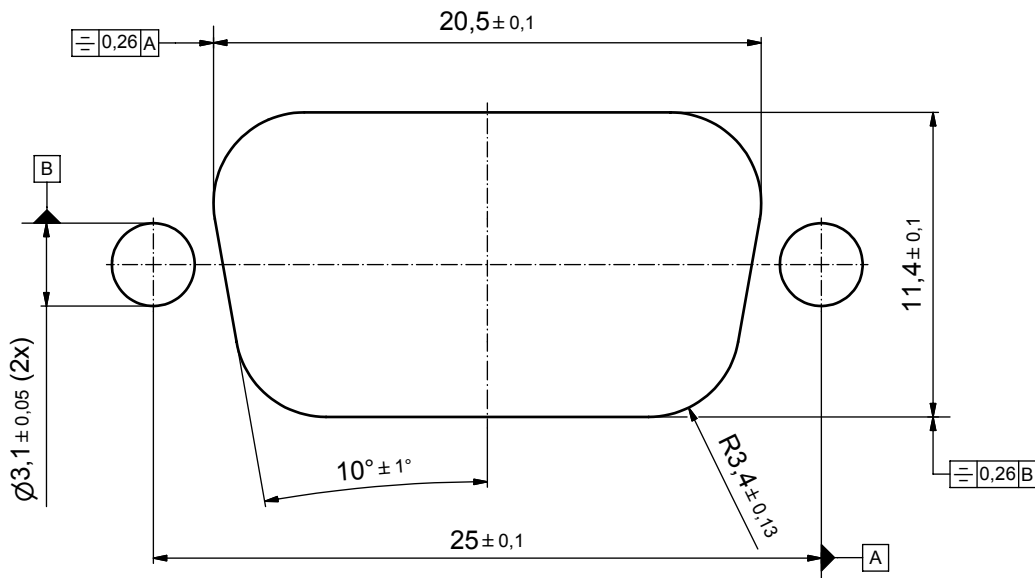

APPROVAL # FREIGABE # DEBLOCAGE # AUTORIZACION # APPROVAL	
CUSTOMER APPROVAL DATE:	
NAME:	TITLE:
COMPANY NAME:	
APPROVAL # FREIGABE # DEBLOCAGE # AUTORIZACION # APPROVAL	

THIS DRAWING MAY NOT BE COPIED OR REPRODUCED IN ANY WAY, AND MAY NOT BE PASSED ON TO A THIRD PARTY WITHOUT WRITTEN PERMISSION. OWNERSHIP AND COPYRIGHT OF CONEC GmbH			
DO NOT ALTER CAD DRAWING BY HAND			
rev.	description	date	name
a	Origin		

tolerance		dim. in mm
date	name	
drawn	23.11.09	Schmidt
appd.	27.11.09	Fischer
norm		
d-old		
<b>CONEC</b>		

scale:	5:1	
material:	see sheet 1	
title:	P.C.B. HOLE DRILLINGS PANEL CUT-OUT D-SUB Female 15pos. HD Solder pin angled 90°	
dwg no:	Inventor 10	DIN-A3
	15K1A500	sh: 2
part no:	see sheet 1	