

DRAWING MADE IN THIRD ANGLE PROJECTION

566412 566412

PART NUMBER	REV	FIRST USED	MACHINE REFERENCE	FEED TYPE
566412-1	F	356462-2	G-SPLICE TERM	AIR FEED
566412-2	G	2161300-1	5K CE & GI THRU SPLICE	AIR FEED
7-566412-7	F	356462-2	SPARE PARTS KIT	-
7-566412-8	G	-	CONV. KIT FOR -1 TO -2	-

TERMINAL NAME: SPLICE		CRIMPING DATA			
1217440					
PAD NO.	CRIMP HEIGHT	WIRE SIZE	WIRE SET UP		
5	.076 ±.002 [1.93 ±0.05mm]	.045 CABLE	CUSTOMER WIRE		
4	NOT	USED	-		
4	NOT	USED	-		
3	NOT	USED	-		
CRIMP	SIZE	TYPE	RANGE		
WIRE	.130 [3.30mm]	F	-		
INSUL	-	-	-		
WIRE STRIP LENGTH	TERM APPL SPEC	FEED	APPL INSTRUCTION	SET UP GAGE	LAYOUT
-	114-2088	.620	408-8318(-1) 408-127000(-2)	-	L2561

QTY REQD PER ASSY	PART NO	DESCRIPTION	ITEM NO			
2	18029-2	M4 HEX NUT	129			
2	18025-2	M4 LOCK WASHER	128			
2	18027-2	M4 FLAT WASHER	127			
1	408-32162	THRU SPLICE IS SHEET-GII	126			
-	408127000	THRU SPLICE IS SHEET	125			
-	217238-1	GENERAL INSTRUCTION PACKAGE	124			
-	4088-8318	THRU SPLICE IS SHEET	123			
-	4-21028-0	PIN,SLT SPR(Ø.093x.75)ST GDE PL	121			
-	-	-	120			
-	-	-	119			
-	-	-	118			
-	3	21024-5	WASHER, LOCK(#10)ADJ BLOCK	117		
-	-	-	116			
-	-	-	115			
-	2	21024-2	WASHER,LOCK(#4)FRONT STP GUIDE	114		
-	-	-	113			
-	2	21024-3	LOCK WASHER #6	112		
-	2	21024-4	WASHER,LOCK(#8)STRIPPER	111		
-	AR	21899-2	WASHER,FLAT(#10)	110		
-	-	-	109			
2	3-18023-3	SCR,SHC (M6 X 50)	108			
-	2	2-18023-9	SCR,SHC (M6 X 20)	107		
-	1	2-21000-6	SCR,SHC (8-32x.38)WIRE STOP	106		
-	-	-	105			
-	-	-	104			
-	1	690701-2	PLATE IDENTIFICATION	103		
-	-	-	102			
-	1	819347-1	PLATE, IDENTIFICATION	101		
-	AR	982057-2	TAPE, POLYURETHANE FOAM	100		
-	2	3-21002-0	SCR,BHC(10-32x.88)DRAG	99		
-	1	22733-8	SCR,BHC(8-32x.38 LW)ANVIL	98		
-	-	-	97			
-	2	2-22733-8	SCR,BHC(1/4-20x.62)FEED	96		
-	1	2-21002-7	SCR,BHC(10-32x.50)SG ADJ BLK	95		
-	4	2-21002-2	SCR,BHC(8-32x.50)TERM H DWN	94		
-	2	2-21002-1	SCR,BHC(8-32x.38)HOLDER	93		
-	2	2-21002-4	SCR, BHC (8-32 X .75)	92		
-	2	21022-2	NUT,LOCK	91		
-	2	2-21002-3	SCR, BHC (8-32x.62)WIRE STOP	90		
-	3	21055-6	WASHER,FLAT	89		
-	4	1-21002-0	SCR,BHC(2-56 x .25)GUARD	88		
-	2	2-21002-6	SCR, BHC (10x32 x .38)	87		
-	1	2-22603-1	SCR,HEX HD(8-32x.38)FEED FINGER	86		
-	2	1-21000-3	SCR,SHC(4-40x.25)F ST GUIDE	85		
-	1	2-21000-7	SCR,SHC(8-32x.50)STRIPPER	84		
-	4	21018-3	NUT, HEX (2-56)GUARD	83		
-	2	3-21000-4	SCR,SHC(10-32x.38)GUARD	82		
-	1	3-22603-1	SCR,HEX(10-32x.38)SG ADJ BL	81		
-	1	3-21001-5	SCR, BHC (3/8-16 x 1.00)	80		
-	1	21024-8	LOCK WASHER .375	79		
-	1	1338118-1	MOUNT, STRIPPER	78		
-	2	1-21000-9	SCR,SHC(6-32x.38)STR MOUNT	77		
-	-	-	76			
-	-	-	75			
-	1	1338176-1	GUARD, EXTENSION	74		
-	1	1338177-1	DEFLECTOR	73		
-	2	21002-9	SCR,BHC(2-56 x .19)DEFL	72		
-	1	1338174-1	WINDOW, GUARD	71		
-	1	1338116-1	BRACKET, FEED	70		
-78	-77	-2	-1	PART NO	DESCRIPTION	ITEM NO

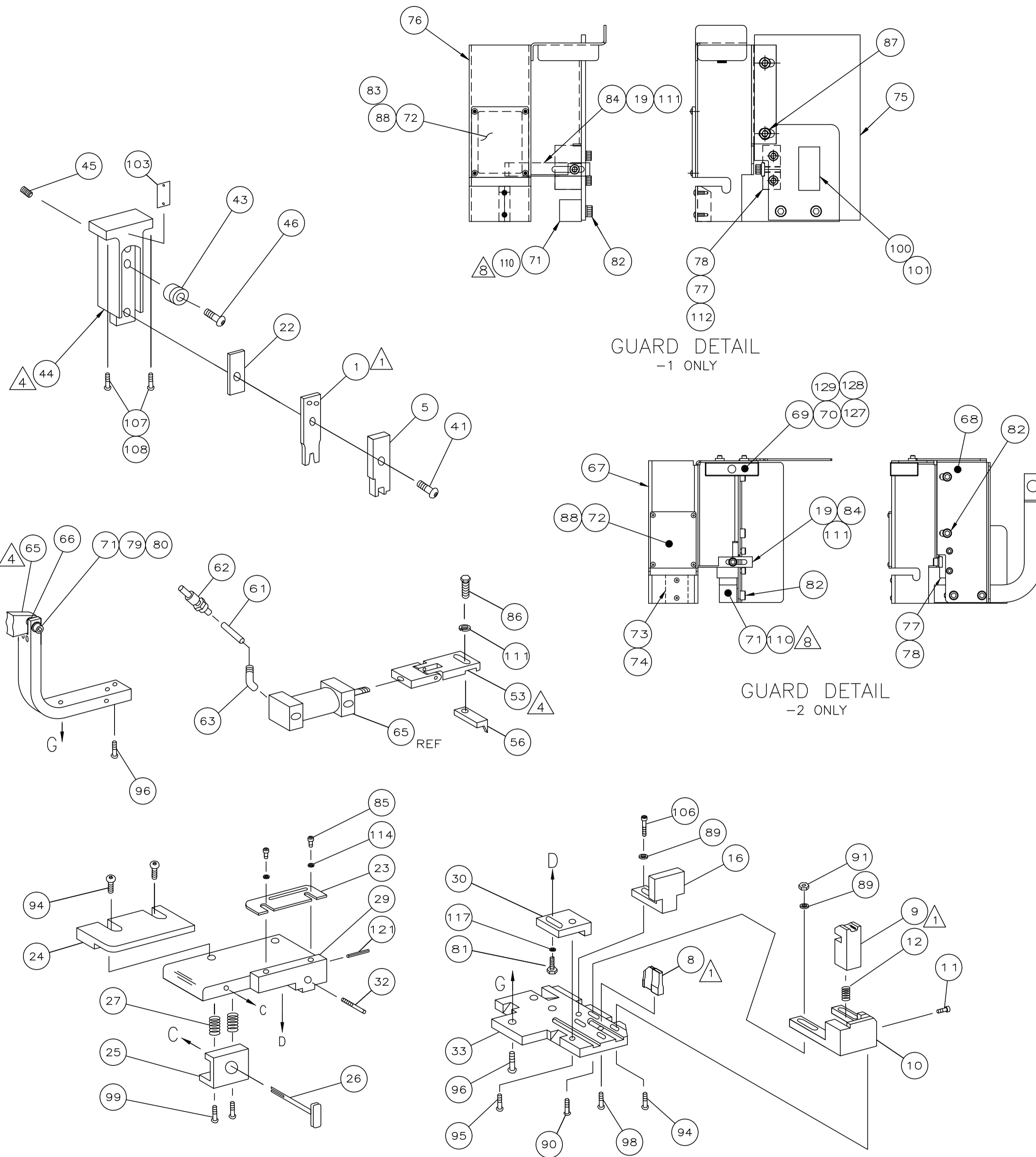

- 1 RECOMMENDED SPARE PARTS.
- 2 GREASE LIGHTLY.
- 3 GUARD MUST BE IN PLACE WHEN OPERATING APPLICATOR IN A BENCH MACHINE.
- 4 SEE DRAWING FOR COMPONENTS
- 5 ITEM NOT SHOWN
- 6 MUST REACH 80 LBS MIN CRIMP TENSILE REQ BY SCOTTS CO.
- 7 LOC-TITE
- 8 PLACE ITEM 112 BETWEEN ITEM 71 AND 75 ON -1. PLACE ITEM 112 BETWEEN ITEM 71 AND 68 ON -2.

QTY REQD PER ASSY	REVISION OF EACH ASSY NO (WHEN BLANK, USE DWG REVISION)	PART NO	DESCRIPTION	ITEM NO	
2	-	2	1-18023-3	SCR, SHC, M4 X 16	70
1	-	1	2168489-1	ACTUATOR, SPARE MC1	69
1	-	1	2161461-1	GUARD, EXTENSION	68
1	-	1	2161460-1	GUARD	67
-	-	1	371178	BASE MOUNT WASHER	66
-	-	1	461065-1	AIR FEED ASSY (1 INCH)	65
-	-	2	3-21000-7	SCR,SHC(10-32x.75)AIR ASSY	64
-	-	1	980285-2	ELBOW, SWIVEL 1/8 NPT - 1/4 T	63
-	-	1	23238-1	QUICK DISCONNECT	62
-	-	21.00	21.00	TUBING, POLY-FLO Ø.25	61
-	-	-	-	-	60
-	-	-	-	-	59
-	-	-	-	-	58
-	-	-	-	-	57
-	-	1	458537-2	PAWL, FEED	56
-	-	-	-	-	55
-	-	-	-	-	54
-	-	1	1-461062-1	FEED FINGER ASSY	53
-	-	-	-	-	52
-	-	-	-	-	51
-	-	-	-	-	50
-	-	-	-	-	49
-	-	-	-	-	48
-	-	-	-	-	47
-	-	1	21004-9	SCR,SHC(.31 X .50)WHEEL ADJ	46
-	-	1	27058-2	BALL PLUNGER	45
-	-	1	1338117-1	TOOL HOLDER	44
-	-	1	1338124-1	WHEEL, ADJ	43
-	-	-	-	-	42
-	-	1	7-21002-9	BOLT, CRIMPER(5/16x1.00)	41
-	-	-	-	-	40
-	-	-	-	-	39
-	-	-	-	-	38
-	-	-	-	-	37
-	-	-	-	-	36
-	-	-	-	-	35
-	-	-	-	-	34
-	-	1	1338397-1	PLATE, BASE	33
-	-	1	690432-3	SCREW, ADJUSTMENT	32
-	-	-	-	-	31
-	-	1	455689-1	BLOCK, STRIP GUIDE ADJ	30
-	-	1	1424398-1	PLATE, STRIP GUIDE,MOD	29
-	-	-	-	-	28
-	-	2	1-22284-0	SPRING, DRAG	27
-	-	1	690546-1	LEVER, DRAG RELEASE	26
-	-	1	240792-1	DRAG, TERMINAL	25
-	-	1	6-690440-5	GUIDE, STRIP (REAR)	24
-	-	1	690438-1	GUIDE, STRIP (FRONT)	23
-	-	1	1338200-5	SPACER, WIRE CRIMPER	22
-	-	-	-	-	21
-	-	-	-	-	20
-	-	1	1-690472-6	STRIPPER	19
-	-	-	-	-	18
-	-	-	-	-	17
-	-	1	1424399-1	WIRE STOP	16
-	-	-	-	-	15
-	-	-	-	-	14
-	-	-	-	-	13
-	-	1	5-22280-0	SPRING, SHEAR	12
-	-	1	690461-3	STOP, SHEAR	11
-	-	1	90769-1	HOLDER, SHEAR (FRONT)	10
-	1	1	2-454276-2	SHEAR, FLOAT (FRONT)	9
-	1	1	1424379-1	ANVIL	8
-	-	-	-	-	7
-	-	-	-	-	6
-	-	1	1424380-1	DEPRESSOR, SHEAR (FRONT)	5
-	-	-	-	-	4
-	-	-	-	-	3
-	-	-	-	-	2
-	1	1	1338125-6	CRIMPER, WIRE	1

DIMENSIONS IN INCHES. DO NOT SCALE PRINT. TOLERANCES UNLESS OTHERWISE SPECIFIED:
 DR B.HIGMAN 07/11/01 APP 07/11/01 T.ELBIN
 CHK 07/11/01 B.HIGMAN REL -
 NAME SIDE FEED THRU SPLICE APPLICATOR MACHINE REF G-SPLICE
 SCALE - DWG NO 566412 SHEET 1 of 1 REV G
 QTY REQD PER ASSY PARTS LIST
 G ECR-15-011404 RS 08-15
 F1 ECR-11-024747 RS 12-11
 F ECR-06-002908 GB 2-06
 E ECN 0150-1585-02 TE 12-02
 D ECN 0150-0950-02 TE 5-02
 C 0150-0280-02 CE MAR02
 B ECN 0150-1087-01 TE 10-01
 A PRODUCT RELEASE CMR AUG01
 P F LTR REVISION RECORD APP DATE
 ONE CODE 00779
 CUSTOMER AND ASSEMBLY DRAWING
 RESTRICTED TO

THIS DRAWING IS A CONTROLLED DOCUMENT.

FEB 21, 2000
 RELEASED FOR PUBLICATION
 BY AMP INCORPORATED. ALL RIGHTS RESERVED.
 THIS DRAWING IS UNCLASSIFIED
 COPYRIGHT 2000
 LCA
 DIST
 66

566412

C

B

A