

## PIC32MX250F128D USB/Graphics 44-pin to 100-pin Plug-In Module (PIM) Information Sheet

The PIC32MX250F128D PIM is designed to demonstrate the capabilities of the PIC32MX1XX/2XX family of devices using development boards such as the Explorer 16 Development Board, which supports 100-pin PIM interfaces.

The PIC32MX1XX/2XX family of devices are high-performance 32-bit microcontrollers in low-pin count packages.

Table 1 shows the mapping between the development board functions and the device pins.

**TABLE 1: 44-PIN TO 100-PIN PINOUT**

Device Pin #	PIC32MX250F128D	PIM Pin #	Functional Description
1	RPB9/SDA1/CTED4/PMD3/RB9	99	PMPD3
2	RPC6/PMA1/RC6	43	ALH
3	RPC7/PMA0/RC7	44	ALL
4	RPC8/PMA5/RC8	68	YU
5	RPC9/CTED7/PMA6/RC9	69	XL
6	Vss	15	Vss
7	VCAP	85	VCAP
8	PGED2/RPB10/D+/CTED11/RB10	90	D+
9	PGEC2/RPB11/D-/RB11	89	D-
10	VUSB	2	VDD
11	AN11/RPB13/CTPLS/PMRD/RB13	82	PMPRD
12	TMS/PMA10/RA10	8	POWER/ PGED
13	CK/CTED8/PMA7/RA7	26	PGEC
14	CVREF/AN10/C3INB/RPB14/VBUSON/SCK1/CTED5/RB14	7	RS
15	AN9/C3INA/RPB15/SCK2/CTED6/PMCS1/RB15	70	CS
16	AVss	36	AVss
17	AVDD	30	AVDD
18	MCLR	13	MCLR
19	PGED3/VREF+/CVREF+/AN0/C3INC/RPA0/CTED1/PMD7/RA0	5	PMPD7
20	PGEC3/VREF-/CVREF-/AN1/RPA1/CTED2/PMD6/RA1	4	PMPD6
21	PGED1/AN2/C1IND/C2INB/C3IND/RPB0/PMD0/RB0	93	PMPD0
22	PGEC1/AN3/C1INC/C2INA/RPB1/CTED12/PMD1/RB1	94	PMPD1

Device Pin #	PIC32MX250F128D	PIM Pin #	Functional Description
23	AN4/C1INB/C2IND/RPB2/SDA2/CTED13/PMD2/CNB2/RB2	98	PMPD2
24	AN5/C1INA/C2INC/RTCC/RPB3/SCL2/PMWR/CNB3/RB3	81	PMPWR
25	AN6/RPC0/RC0	34	YD
26	AN7/RPC1/RC1	35	XR
27	AN8/RPC2/PMA2/RC2	10	EEPROM_SCK
28	VDD	62	VDD
29	Vss	65	Vss
30	OSC1/CLKI/RPA2/RA2	63	OSCI
31	OSC2/CLKO/RPA3/RA3	64	OSCO
32	TDO/RPA8/PMA8/RA8	76	FLASH_CS1
33	SOSCI/RPB4/RB4	72	BUZZER
34	SOSCO/RPA4/T1CK/CTED9/RA4	6	RST
35	TDI/RPA9/PMA9/RA9	77	WAIT
36	AN12/RPC3/RC3	78	BE
37	RPC4/PMA4/RC4	95	USBID/AN16
38	RPC5/PMA3/RC5	1	AN17/VBUS
39	Vss	31	Vss
40	VDD	2	VDD
41	PB5/USBID/RB5	95	USBID/AN16
42	VBUS	1	AN17/VBUS
43	RPB7/CTED3/PMD5/INT0/RB7	3	PMPD5
44	RPB8/SCL1/CTED10/PMD4/RB8	100	PMPD4

# PIC32MX250F128D

**FIGURE 1: 100-PIN HEADER SCHEMATIC**

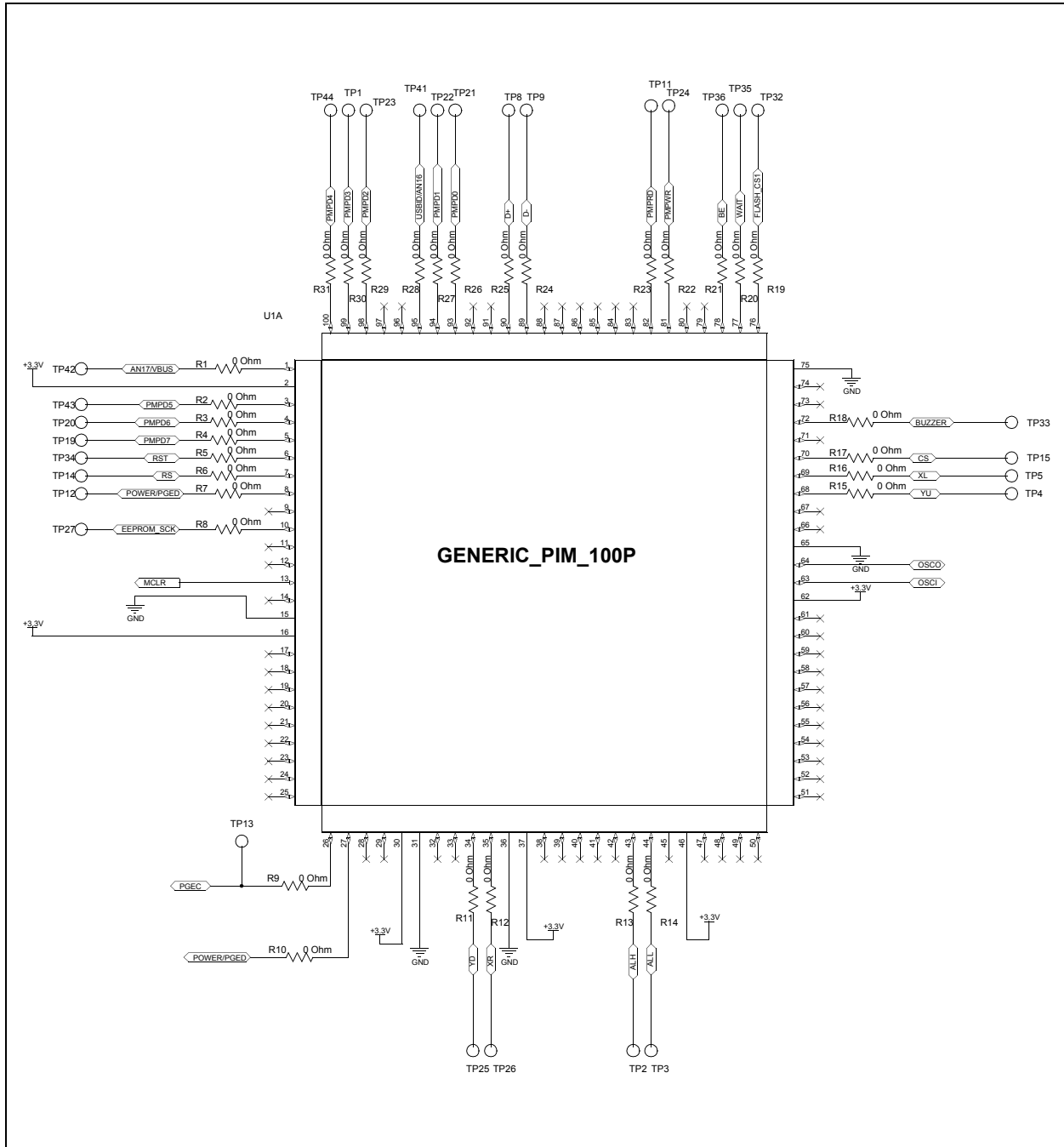

**FIGURE 2: 44-PIN DEVICE SCHEMATIC**

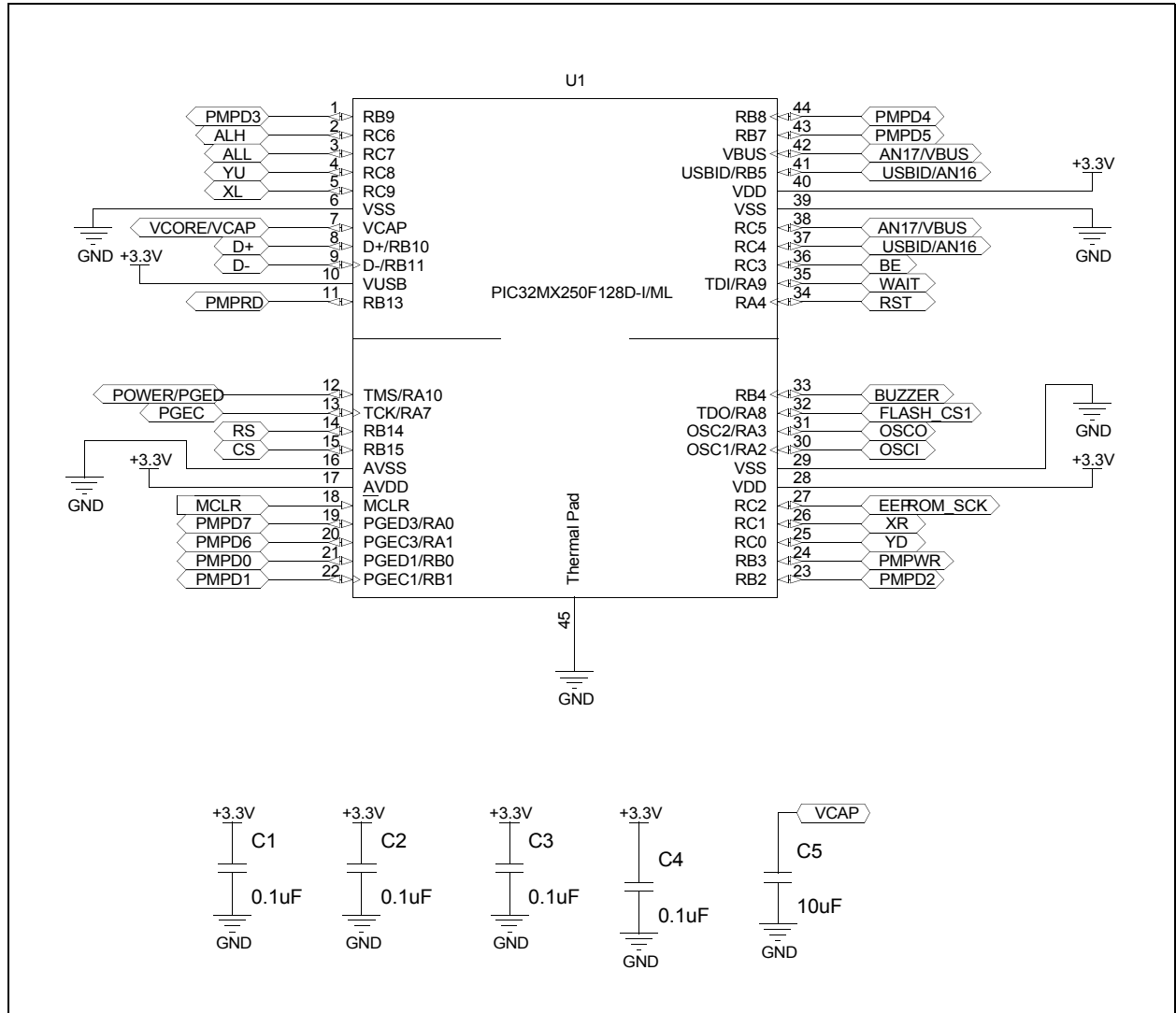

# PIC32MX250F128D

---

## REVISION HISTORY

### Revision A (September 2011)

This is the initial released version of this document.

### Revision B (January 2012)

Added a notice regarding usage with the USB PICtail™ Plus Daughter Board.

### Revision C (March 2012)

This revision includes the following updates:

- Removed note regarding usage with the USB PICtail™ Plus Daughter Board
- Updated device to PIC32MX250F128D
- Updated schematics (see [Figure 1](#) and [Figure 2](#))

### Revision D (May 2012)

In this revision, the following pins were updated (see [Table 1](#)):

- Pin 1: ASDA1 was changed to SDA1
- Pin 19: SDA1 was removed
- Pin 20: SCL1 was removed
- Pin 23: ASDA2 was changed to SDA2
- Pin 24: ASCL2 was changed to SCL2
- Pin 44: ASCL1 was changed to SCL1

---

---

**Note the following details of the code protection feature on Microchip devices:**

- Microchip products meet the specification contained in their particular Microchip Data Sheet.
- Microchip believes that its family of products is one of the most secure families of its kind on the market today, when used in the intended manner and under normal conditions.
- There are dishonest and possibly illegal methods used to breach the code protection feature. All of these methods, to our knowledge, require using the Microchip products in a manner outside the operating specifications contained in Microchip's Data Sheets. Most likely, the person doing so is engaged in theft of intellectual property.
- Microchip is willing to work with the customer who is concerned about the integrity of their code.
- Neither Microchip nor any other semiconductor manufacturer can guarantee the security of their code. Code protection does not mean that we are guaranteeing the product as "unbreakable."

Code protection is constantly evolving. We at Microchip are committed to continuously improving the code protection features of our products. Attempts to break Microchip's code protection feature may be a violation of the Digital Millennium Copyright Act. If such acts allow unauthorized access to your software or other copyrighted work, you may have a right to sue for relief under that Act.

---

Information contained in this publication regarding device applications and the like is provided only for your convenience and may be superseded by updates. It is your responsibility to ensure that your application meets with your specifications. MICROCHIP MAKES NO REPRESENTATIONS OR WARRANTIES OF ANY KIND WHETHER EXPRESS OR IMPLIED, WRITTEN OR ORAL, STATUTORY OR OTHERWISE, RELATED TO THE INFORMATION, INCLUDING BUT NOT LIMITED TO ITS CONDITION, QUALITY, PERFORMANCE, MERCHANTABILITY OR FITNESS FOR PURPOSE. Microchip disclaims all liability arising from this information and its use. Use of Microchip devices in life support and/or safety applications is entirely at the buyer's risk, and the buyer agrees to defend, indemnify and hold harmless Microchip from any and all damages, claims, suits, or expenses resulting from such use. No licenses are conveyed, implicitly or otherwise, under any Microchip intellectual property rights.

**Trademarks**

The Microchip name and logo, the Microchip logo, dsPIC, KEELOQ, KEELOQ logo, MPLAB, PIC, PICmicro, PICSTART, PIC<sup>32</sup> logo, rPIC and UNI/O are registered trademarks of Microchip Technology Incorporated in the U.S.A. and other countries.

FilterLab, Hampshire, HI-TECH C, Linear Active Thermistor, MXDEV, MXLAB, SEEVAL and The Embedded Control Solutions Company are registered trademarks of Microchip Technology Incorporated in the U.S.A.

Analog-for-the-Digital Age, Application Maestro, chipKIT, chipKIT logo, CodeGuard, dsPICDEM, dsPICDEM.net, dsPICworks, dsSPEAK, ECAN, ECONOMONITOR, FanSense, HI-TIDE, In-Circuit Serial Programming, ICSP, Mindi, MiWi, MPASM, MPLAB Certified logo, MPLIB, MPLINK, mTouch, Omniscent Code Generation, PICC, PICC-18, PICDEM, PICDEM.net, PICkit, PICtail, REAL ICE, rLAB, Select Mode, Total Endurance, TSHARC, UniWinDriver, WiperLock and ZENA are trademarks of Microchip Technology Incorporated in the U.S.A. and other countries.

SQTP is a service mark of Microchip Technology Incorporated in the U.S.A.

All other trademarks mentioned herein are property of their respective companies.

© 2011-2012, Microchip Technology Incorporated, Printed in the U.S.A., All Rights Reserved.

 Printed on recycled paper.

ISBN: 978-1-62076-294-3

**QUALITY MANAGEMENT SYSTEM  
CERTIFIED BY DNV  
= ISO/TS 16949 =**

*Microchip received ISO/TS-16949:2009 certification for its worldwide headquarters, design and wafer fabrication facilities in Chandler and Tempe, Arizona; Gresham, Oregon and design centers in California and India. The Company's quality system processes and procedures are for its PIC<sup>®</sup> MCUs and dsPIC<sup>®</sup> DSCs, KEELOQ<sup>®</sup> code hopping devices, Serial EEPROMs, microperipherals, nonvolatile memory and analog products. In addition, Microchip's quality system for the design and manufacture of development systems is ISO 9001:2000 certified.*



# MICROCHIP

## Worldwide Sales and Service

### AMERICAS

**Corporate Office**  
2355 West Chandler Blvd.  
Chandler, AZ 85224-6199  
Tel: 480-792-7200  
Fax: 480-792-7277  
Technical Support:  
<http://www.microchip.com/support>  
Web Address:  
[www.microchip.com](http://www.microchip.com)

**Atlanta**  
Duluth, GA  
Tel: 678-957-9614  
Fax: 678-957-1455

**Boston**  
Westborough, MA  
Tel: 774-760-0087  
Fax: 774-760-0088

**Chicago**  
Itasca, IL  
Tel: 630-285-0071  
Fax: 630-285-0075

**Cleveland**  
Independence, OH  
Tel: 216-447-0464  
Fax: 216-447-0643

**Dallas**  
Addison, TX  
Tel: 972-818-7423  
Fax: 972-818-2924

**Detroit**  
Farmington Hills, MI  
Tel: 248-538-2250  
Fax: 248-538-2260

**Indianapolis**  
Noblesville, IN  
Tel: 317-773-8323  
Fax: 317-773-5453

**Los Angeles**  
Mission Viejo, CA  
Tel: 949-462-9523  
Fax: 949-462-9608

**Santa Clara**  
Santa Clara, CA  
Tel: 408-961-6444  
Fax: 408-961-6445

**Toronto**  
Mississauga, Ontario,  
Canada  
Tel: 905-673-0699  
Fax: 905-673-6509

### ASIA/PACIFIC

**Asia Pacific Office**  
Suites 3707-14, 37th Floor  
Tower 6, The Gateway  
Harbour City, Kowloon  
Hong Kong  
Tel: 852-2401-1200  
Fax: 852-2401-3431

**Australia - Sydney**  
Tel: 61-2-9868-6733  
Fax: 61-2-9868-6755

**China - Beijing**  
Tel: 86-10-8569-7000  
Fax: 86-10-8528-2104

**China - Chengdu**  
Tel: 86-28-8665-5511  
Fax: 86-28-8665-7889

**China - Chongqing**  
Tel: 86-23-8980-9588  
Fax: 86-23-8980-9500

**China - Hangzhou**  
Tel: 86-571-2819-3187  
Fax: 86-571-2819-3189

**China - Hong Kong SAR**  
Tel: 852-2401-1200  
Fax: 852-2401-3431

**China - Nanjing**  
Tel: 86-25-8473-2460  
Fax: 86-25-8473-2470

**China - Qingdao**  
Tel: 86-532-8502-7355  
Fax: 86-532-8502-7205

**China - Shanghai**  
Tel: 86-21-5407-5533  
Fax: 86-21-5407-5066

**China - Shenyang**  
Tel: 86-24-2334-2829  
Fax: 86-24-2334-2393

**China - Shenzhen**  
Tel: 86-755-8203-2660  
Fax: 86-755-8203-1760

**China - Wuhan**  
Tel: 86-27-5980-5300  
Fax: 86-27-5980-5118

**China - Xian**  
Tel: 86-29-8833-7252  
Fax: 86-29-8833-7256

**China - Xiamen**  
Tel: 86-592-2388138  
Fax: 86-592-2388130

**China - Zhuhai**  
Tel: 86-756-3210040  
Fax: 86-756-3210049

### ASIA/PACIFIC

**India - Bangalore**  
Tel: 91-80-3090-4444  
Fax: 91-80-3090-4123

**India - New Delhi**  
Tel: 91-11-4160-8631  
Fax: 91-11-4160-8632

**India - Pune**  
Tel: 91-20-2566-1512  
Fax: 91-20-2566-1513

**Japan - Osaka**  
Tel: 81-66-152-7160  
Fax: 81-66-152-9310

**Japan - Yokohama**  
Tel: 81-45-471-6166  
Fax: 81-45-471-6122

**Korea - Daegu**  
Tel: 82-53-744-4301  
Fax: 82-53-744-4302

**Korea - Seoul**  
Tel: 82-2-554-7200  
Fax: 82-2-558-5932 or  
82-2-558-5934

**Malaysia - Kuala Lumpur**  
Tel: 60-3-6201-9857  
Fax: 60-3-6201-9859

**Malaysia - Penang**  
Tel: 60-4-227-8870  
Fax: 60-4-227-4068

**Philippines - Manila**  
Tel: 63-2-634-9065  
Fax: 63-2-634-9069

**Singapore**  
Tel: 65-6334-8870  
Fax: 65-6334-8850

**Taiwan - Hsin Chu**  
Tel: 886-3-5778-366  
Fax: 886-3-5770-955

**Taiwan - Kaohsiung**  
Tel: 886-7-536-4818  
Fax: 886-7-330-9305

**Taiwan - Taipei**  
Tel: 886-2-2500-6610  
Fax: 886-2-2508-0102

**Thailand - Bangkok**  
Tel: 66-2-694-1351  
Fax: 66-2-694-1350

### EUROPE

**Austria - Wels**  
Tel: 43-7242-2244-39  
Fax: 43-7242-2244-393

**Denmark - Copenhagen**  
Tel: 45-4450-2828  
Fax: 45-4485-2829

**France - Paris**  
Tel: 33-1-69-53-63-20  
Fax: 33-1-69-30-90-79

**Germany - Munich**  
Tel: 49-89-627-144-0  
Fax: 49-89-627-144-44

**Italy - Milan**  
Tel: 39-0331-742611  
Fax: 39-0331-466781

**Netherlands - Druenen**  
Tel: 31-416-690399  
Fax: 31-416-690340

**Spain - Madrid**  
Tel: 34-91-708-08-90  
Fax: 34-91-708-08-91

**UK - Wokingham**  
Tel: 44-118-921-5869  
Fax: 44-118-921-5820

11/29/11