

PART NUMBER	REV	FIRST USED	POWER UNIT	FEED TYPE	DESCRIPTION
1855450-1	A	122500-1	LEADMAKER	AIR FEED	CUTS CARRIER
1855450-2	A	565435-5	BENCH MODEL K	AIR FEED	CUTS CARRIER
1855450-3	A	354500-1	BENCH MODEL G	AIR FEED	CUTS CARRIER
7-1855450-7	A	-	-	-	SPARE PARTS

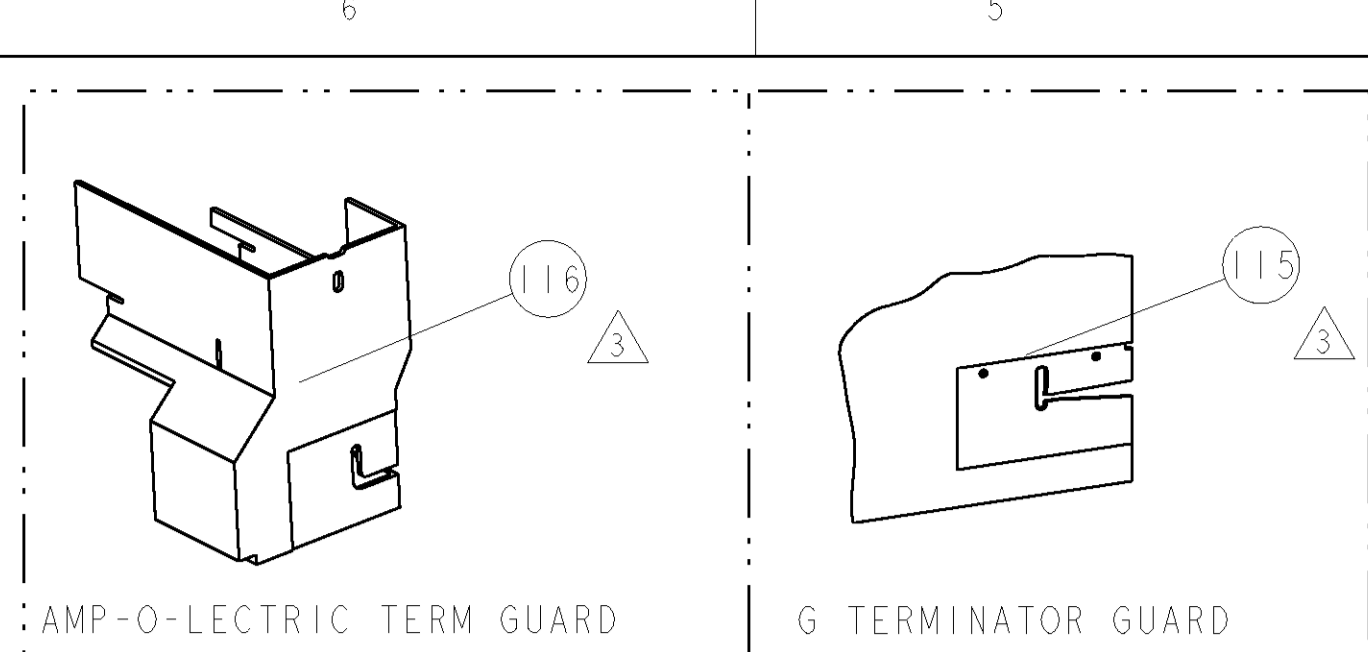

TE P/N		DELPHI		DELPHI TERMINAL - TE CRIMP SPECS		REF SETTING
1949827	13517635					
				CRIMP HEIGHT	WIRE SIZE	
				2.16mm±.08/.08 [.085+.003/- .003]	0.8mm2 or 18AWG	C2
				2.06mm±.08/.08 [.081+.003/- .003]	0.5mm2 or 20AWG	D0
				CRIMP	SIZE	TYPE
						RANGE
				WIRE	3.18mm [.125]	F
				INSUL	3.94mm [.155]	O
						0.5-0.8mm2 or 20-18AWG
WIRE STRIP LENGTH	TERM APPL SPEC	FEED	APPLICATOR INSTRUCTIONS		SET UP GAGE	
4.47-4.85	NONE	13.89	408-8040		458637-1	

LOC	DIST	REVISIONS			
A	66	P LTR	DESCRIPTION	DATE	DWN
		A	RELEASED	09FEB2009	RR

- △ RECOMMENDED SPARE PARTS
 - △ GREASE LIGHTLY
 - △ GUARD MUST BE IN PLACE WHEN OPERATING APPLICATOR IN A BENCH MACHINE
 - △ GRIND AT ASSEMBLY.
5. TERMINAL LUBRICANT IS RECOMMENDED.
- △ INSTALL ITEMS 101, 102 & 119 ON SIDE OF STRIPPER ON APPLICATOR HOUSING USING ITEM 21.

*** WARNING**
ON INSTALLATION, SET WIRE DISC TO LARGEST WIRE SIZE SETTING. USE OF SETTINGS BELOW MIN. REQUIRED CRIMP HEIGHT SETTING WILL CAUSE DAMAGE TO CRIMP TOOLING.

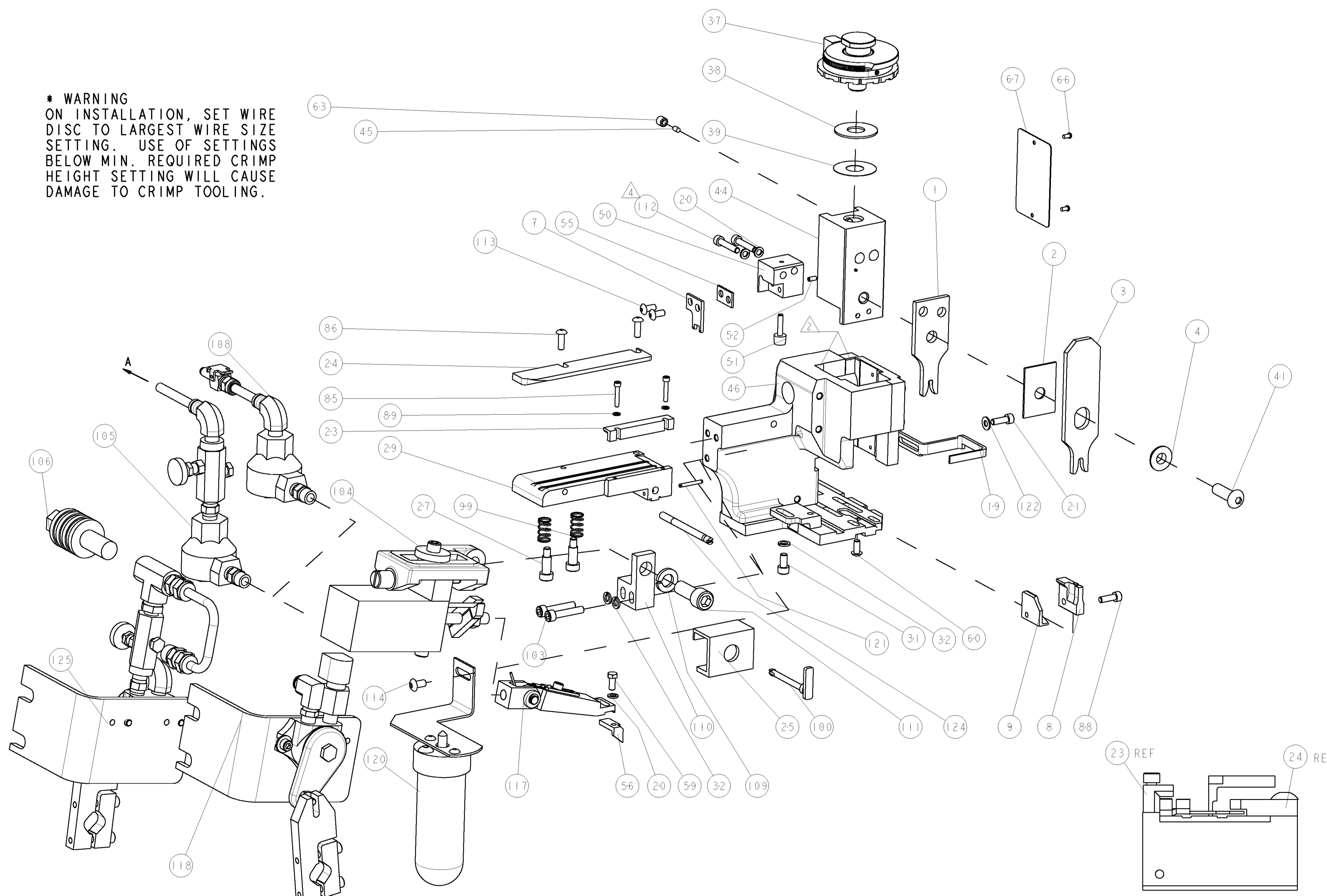

-	-	1	-	-	455350-4	AIR BLAST ASS'Y	125	
-	-	1	1	1	690432-6	ADJUSTMENT SCREW	124	
-	-	1	1	1	21055-6	WASHER, FLAT, REG NO 8	122	
-	-	1	1	1	4-21028-0	PIN, SLOTTED SPRING .094 X .750	121	
-	-	1	1	1	1-465184-0	LUBRICATOR ASSY	120	
△	6	-	18	24	18	IN 27319-4	TUBING 1/4" O.D.	119
-	-	1	1	1	692655-6	AIR FEED VALVE ASSEMBLY	118	
-	-	1	1	1	461062-1	FEED FINGER ASSEMBLY	117	
△	3	-	-	REF	-	455749-1	GUARD WINDOW	116
△	3	-	-	REF	-	679532-1	INSERT, GUARD	115
-	-	1	1	1	2-21002-6	SCR, BTN SKT HD CAP 10-32 X .375	114	
-	-	2	2	2	2	2-21002-1	SCR, BTN SKT HD CAP 8-32 X .375	113
△	4	-	2	2	2	3-21000-0	SCR, SKT HD CAP 8-32 X .875	112
-	-	1	1	1	1	3-21001-5	SCR, SKT HD CAP 3/8-16 X 1.000	111
-	-	1	1	1	1	459610-1	MOUNT, FEED BRACKET	110
-	-	1	1	1	1	21024-8	WASHER, SPRG LOCK, REG 3/8	109
-	-	1	1	1	1	692655-7	AIR FEED VALVE ASSEMBLY	108
-	-	1	1	1	1	24042-2	VALVE, SLEEVE, 3-WAY	106
-	-	1	1	1	1	692655-5	AIR FEED VALVE ASSEMBLY	105
-	-	1	1	1	1	461065-1	ASSEMBLY, AIR FEED	104
-	-	2	2	2	2	3-21000-9	SCR, SKT HD CAP 10-32 X 1.000	103
△	6	-	1	1	1	986220-3	CLAMP, CABLE, BLACK	102
△	6	-	1	1	1	23238-1	INSERT, COUPLING	101
-	-	1	1	1	1	690546-1	LEVER, DRAG RELEASE	100
-	-	2	2	2	2	1-22282-3	SPRING, COMPRESSION	99
-	-	2	2	2	2	21024-2	WASHER, SPRG LOCK, REG NO 4	89
-	-	1	1	1	1	2-21000-7	SCR, SKT HD CAP 8-32 X .500	88
-	-	2	2	2	2	2-21002-2	SCR, BTN SKT HD CAP 8-32 X .500	86
-	-	2	2	2	2	1-21000-6	SCR, SKT HD CAP 4-40 X .625	85
-	-	1	1	1	1	4088040	SF APPL INST 408-8040	72
-	-	1	1	1	1	217238-1	GENERAL INSTRUCTION PKG	71
-	-	1	1	1	1	461264-5	PLATE, IDENTIFICATION	67
-	-	2	2	2	2	21017-2	SCREW, DRIVE	66
-	-	1	1	1	1	21009-2	SCR, SET, SELF LOCKING 1/4-20 X .250	63
-	-	1	1	1	1	22733-8	SCR, BHSC, SELF-LOCKING, 8-32 X .375	60
-	-	1	1	1	1	2-22603-1	SCREW, MACH, HEX HD, 8-32 X .375	59
-	-	1	1	1	1	1-694433-5	FEED PAWL	56
-	-	1	1	1	1	5-240641-4	SPACER	55
-	-	1	1	1	1	2-21008-1	SCR, SET, SELF LOCKING 1/4-20 X .250	52
-	-	1	1	1	1	811242-7	BUMPER, HOLD DOWN	51
-	-	1	1	1	1	1633513-1	HOLDER, SLUG BLADE	50
-	-	1	1	1	1	1633399-1	APPL., BASIC AIR FEED SUB ASSY	46
-	-	1	1	1	1	690191-1	PLUG, NYLON	45
-	-	1	1	1	1	1-455673-4	RAM, SIDE FEED	44
-	-	1	1	1	1	7-21002-9	SCR, BTN SKT HD CAP 5/16-24 X 1.00	41
-	-	1	1	1	1	690125-1	SHIM SUB-ASSY	39
-	-	1	1	1	1	1-469367-1	SHIM	38
-	-	1	1	1	1	879103-3	FINE ADJUST HEAD ASSEMBLY	37
-	-	3	3	3	3	21024-5	WASHER, SPRG LOCK, REG NO 10	32
-	-	1	1	1	1	3-21000-4	SCR, SKT HD CAP 10-32 X .375	31
-	-	1	1	1	1	3-455671-3	PLATE, STRIP GUIDE	29
-	-	2	2	2	2	27210-3	SCR, SHLD, HEX HD, 1/4 DIA	27
-	-	1	1	1	1	6-690754-0	DRAG, SPECIAL	25
-	-	1	1	1	1	8-690440-5	GUIDE, REAR STRIP	24
-	-	1	1	1	1	2-690712-6	FRONT STRIP GUIDE	23
-	-	1	1	1	1	2-21000-7	SCR, SKT HD CAP 8-32 X .500	21
-	-	3	3	3	3	21024-4	WASHER, SPRG LOCK, REG NO 8	20
-	-	1	1	1	1	1-456468-1	STRIPPER, SPECIAL	19
△	1	1	1	1	1	1633742-2	PLATE, REAR SHEAR	9
△	1	1	1	1	1	1633758-2	ANVIL, SPECIAL, COMBINATION	8
△	1	1	1	1	1	1-1583859-4	BLADE, SLUG	7
-	-	-	-	-	-	-	-	6
-	-	-	-	-	-	-	-	5
-	-	1	1	1	1	238009-3	BLOCK, FL CRIMPER SPACER	4
△	1	1	1	1	1	1-1633589-9	CRIMPER, INSUL O	3
△	1	1	1	1	1	1-455888-0	SPACER, CRIMPER	2
△	1	1	1	1	1	5-1633588-4	CRIMPER, WIRE	1

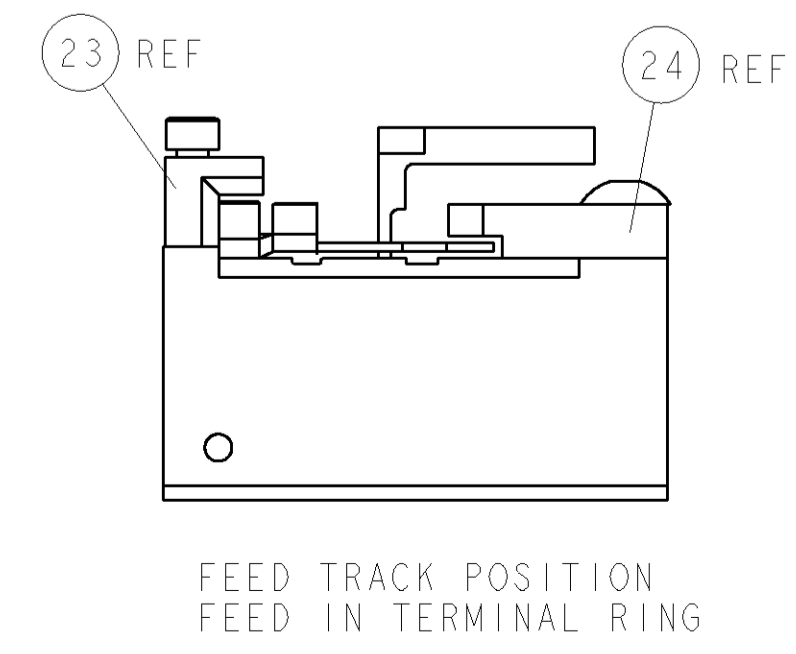

DIMENSIONS:	TOLERANCES UNLESS OTHERWISE SPECIFIED:	DRAWN:	DATE:	APPROVED:	DATE:	NAME:	SCALE:	SHEET:	OF:	REV:
INCHES:	0 PLC ±.1 1 PLC ±.01 3 PLC ±.001 4 PLC ±.0001 ANGLES ±.001	B. HIGMAN	14DEC2008	T. ELBIN	14DEC2008	N. DEMING	3:5	1	1	A
MATERIAL:	FINISH:	WEIGHT:	CUSTOMER DRAWING:	PART NO		DESCRIPTION	ITEM NO			
				77-3-2-1 U/M		FINE ADJUST SIDE FEED HDM APPLICATOR				
CUSTOMER VIEWABLE ASSEMBLY		Tyco Electronics		Tyco Electronics		Harrisburg, PA 17105-3608				