

# W78L32/W78L032A/W78M032A



## 8-BIT MICROCONTROLLER

### **Table of Content-**

1.	GENERAL DESCRIPTION .....	2
2.	FEATURES .....	2
3.	PIN CONFIGURATIONS .....	3
4.	PIN DESCRIPTION.....	4
5.	BLOCK DIAGRAM .....	6
6.	FUNCTIONAL DESCRIPTION .....	7
7.	ABSOLUTE MAXIMUM RATINGS .....	8
8.	DC CHARACTERISTICS .....	8
9.	AC CHARACTERISTICS .....	10
10.	TIMING WAVEFORMS .....	12
11.	TYPICAL APPLICATION CIRCUITS .....	14
12.	PACKAGE DIMENSIONS .....	16
13.	REVISION HISTORY .....	18



## 1. GENERAL DESCRIPTION

The W78L32 microcontroller supplies a wider frequency range and supply voltages than most 8-bit microcontrollers on the market. It is compatible with the industry standard 80C32 microcontroller series.

The W78L32 contains four 8-bit bidirectional parallel ports, three 16-bit timer/counters and a serial port. These peripherals are supported by a six-source, two-level interrupt capability. There are 256 bytes of RAM, and the device supports ROMless operation for application programs.

The W78L32 microcontroller has two power reduction modes, idle mode and power-down mode, both of which are software selectable. The idle mode turns off the processor clock but allows for continued peripheral operation. The power-down mode stops the crystal oscillator for minimum power consumption. The external clock can be stopped at any time and in any state without affecting the processor.

## 2. FEATURES

- Fully static design
- Supply voltage of 1.8V to 5.5V
- Low power consumption at full supply voltage
- DC-24 MHz operation
- 256 bytes of on-chip scratchpad RAM
- 64K bytes program memory address space
- 64K bytes data memory address space
- Four 8-bit bidirectional ports
- Three 16-bit timer/counters
- One full duplex serial port
- Boolean processor
- Six-source, two-level interrupt capability
- Built-in power management
- Packages:
  - DIP 40: W78L32-24
  - PLCC 44: W78L32P-24
  - QFP 44: W78L32F-24
  - Lead Free (RoHS) DIP 40: W78L032A24DL, W78M032A24DL
  - Lead Free (RoHS) PLCC 44: W78L032A24PL, W78M032A24PL
  - Lead Free (RoHS) PQFP 44: W78L032A24FL, W78M032A24FL

# W78L32/W78L032A/W78M032A



## 3. PIN CONFIGURATIONS

40-Pin DIP (W78L32)

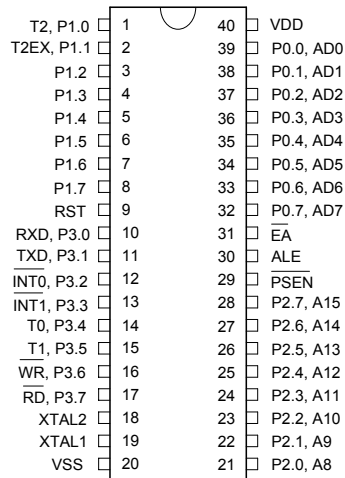

44-Pin PLCC (W78L32P)

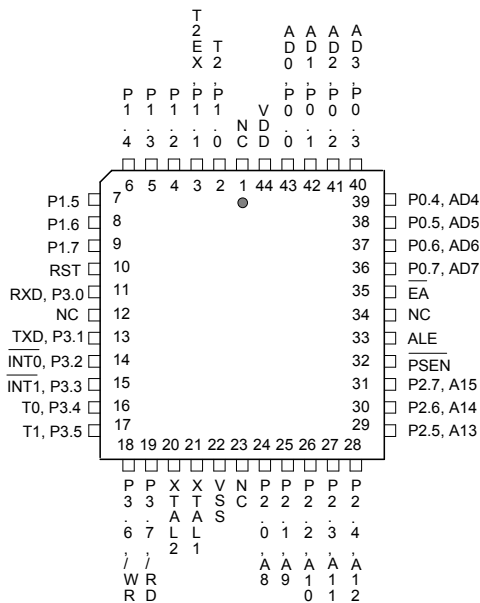

44-Pin QFP (W78L32F)

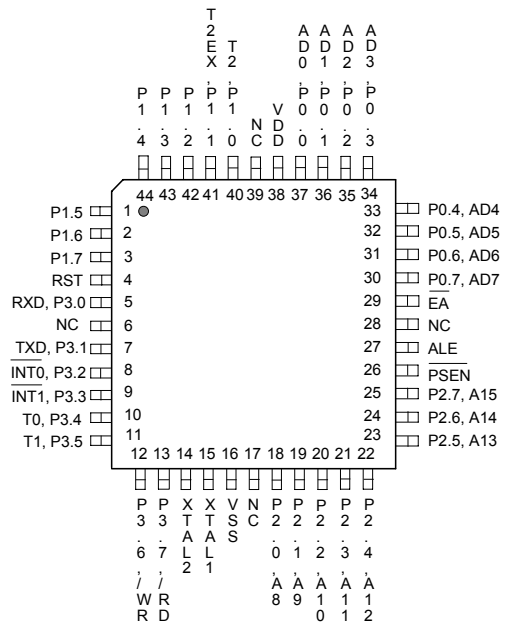



## 4. PIN DESCRIPTION

### P0.0–P0.7

Port 0, Bits 0 through 7. Port 0 is a bidirectional I/O port. This port also provides a multiplexed low order address/data bus during accesses to external memory.

### P1.0–P1.7

Port 1, Bits 0 through 7. Port 1 is a bidirectional I/O port with internal pull-ups. Pins P1.0 and P1.1 also serve as T2 (Timer 2 external input) and T2EX (Timer 2 capture/reload trigger), respectively.

### P2.0–P2.7

Port 2, Bits 0 through 7. Port 2 is a bidirectional I/O port with internal pull-ups. This port also provides the upper address bits for accesses to external memory.

### P3.0–P3.7

Port 3, Bits 0 through 7. Port 3 is a bidirectional I/O port with internal pull-ups. All bits have alternate functions, which are described below:

PIN	ALTERNATE FUNCTION
P3.0	RXD Serial Receive Data
P3.1	TXD Serial Transmit Data
P3.2	$\overline{\text{INT0}}$ External Interrupt 0
P3.3	$\overline{\text{INT1}}$ External Interrupt 1
P3.4	T0 Timer 0 Input
P3.5	T1 Timer 1 Input
P3.6	$\overline{\text{WR}}$ Data Write Strobe
P3.7	$\overline{\text{RD}}$ Data Read Strobe

### $\overline{\text{EA}}$

External Address Input, active low. This pin forces the processor to execute out of external ROM. This pin should be kept low for all W78L32 operations.

### RST

Reset Input, active high. This pin resets the processor. It must be kept high for at least two machine cycles in order to be recognized by the processor.

### ALE

Address Latch Enable Output, active high. ALE is used to enable the address latch that separates the address from the data on Port 0. ALE runs at 1/6th of the oscillator frequency. A single ALE pulse is skipped during external data memory accesses. ALE goes to a high state during reset with a weak pull-up.

# W78L32/W78L032A/W78M032A



## **$\overline{\text{PSEN}}$**

Program Store Enable Output, active low.  $\overline{\text{PSEN}}$  enables the external ROM onto the Port 0 address/data bus during fetch and MOVC operations.  $\overline{\text{PSEN}}$  goes to a high state during reset with a weak pull-up.

## **XTAL1**

Crystal 1. This is the crystal oscillator input. This pin may be driven by an external clock.

## **XTAL2**

Crystal 2. This is the crystal oscillator output. It is the inversion of XTAL1.

## **VSS, VDD**

Power Supplies. These are the chip ground and positive supplies.

## 5. BLOCK DIAGRAM

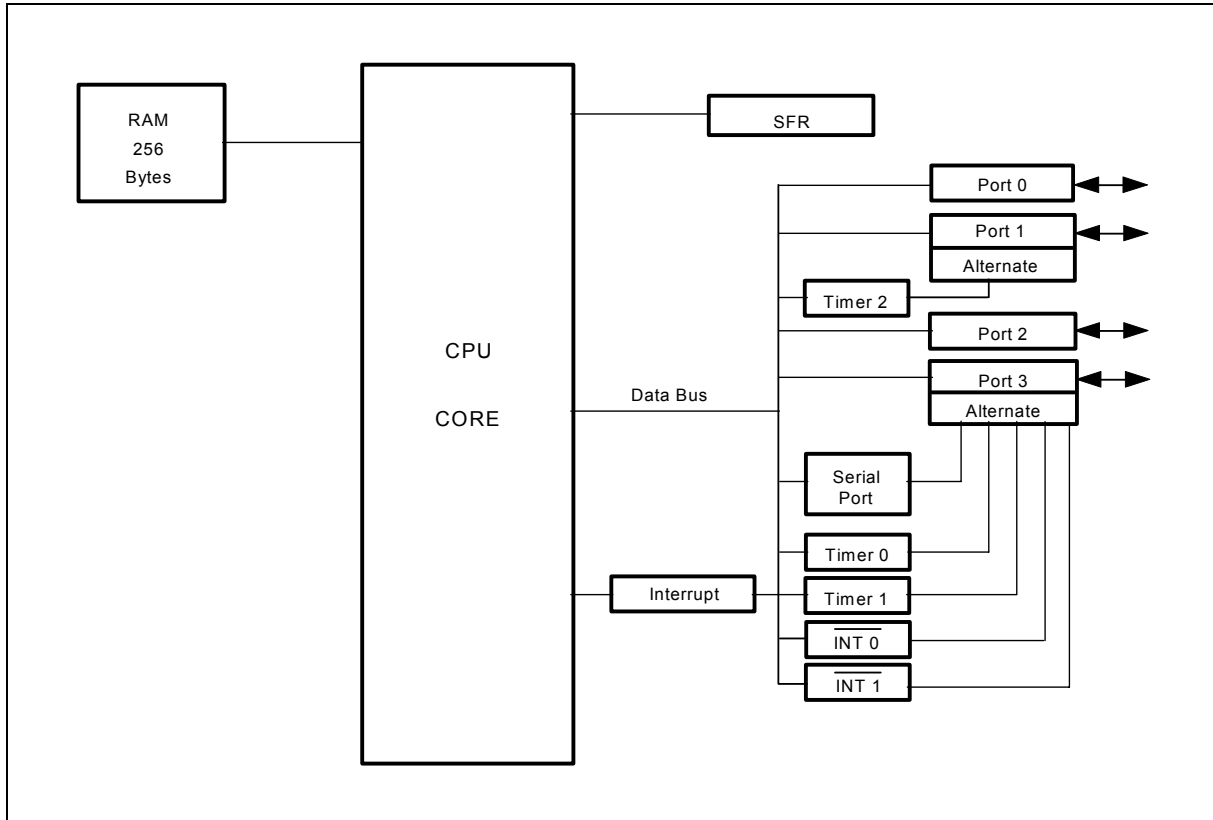



## 6. FUNCTIONAL DESCRIPTION

The W78L32 architecture consists of a core controller surrounded by various registers, four general purpose I/O ports, 256 bytes of RAM, three timer/counters, and a serial port. The processor supports 111 different instruction and references both a 64K program address space and a 64K data storage space.

### Timers 0, 1, and 2

Timers 0, 1, and 2 each consist of two 8-bit data registers. These are called TL0 and TH0 for Timer 0, TL1 and TH1 for Timer 1, and TL2 and TH2 for Timer 2. The TCON and TMOD registers provide control functions for timers 0, 1. The T2CON register provides control functions for Timer 2. RCAP2H and RCAP2L are used as reload/capture registers for Timer 2.

The operations of Timer 0 and Timer 1 are the same as in the W78C31. Timer 2 is a special feature of the W78L32: it is a 16-bit timer/counter that is configured and controlled by the T2CON register. Like Timers 0 and 1, Timer 2 can operate as either an external event counter or as an internal timer, depending on the setting of bit C/T2 in T2CON. Timer 2 has three operating modes: capture, auto-reload, and baud rate generator. The clock speed at capture or auto-reload mode is the same as that of Timers 0 and 1.

### Clock

The W78L32 is designed to be used with either a crystal oscillator or an external clock. Internally, the clock is divided by two before it is used. This makes the W78L32 relatively insensitive to duty cycle variations in the clock.

### Crystal Oscillator

The W78L32 incorporates a built-in crystal oscillator. To make the oscillator work, a crystal must be connected across pins XTAL1 and XTAL2. In addition, a load capacitor must be connected from each pin to ground, and a resistor must also be connected from XTAL1 to XTAL2 to provide a DC bias when the crystal frequency is above 24 MHz.

### External Clock

An external clock should be connected to pin XTAL1. Pin XTAL2 should be left unconnected. The XTAL1 input is a CMOS-type input, as required by the crystal oscillator. As a result, the external clock signal should have an input one level of greater than 3.5 volts when  $V_{DD} = 5V$ .

### Power Management

#### Idle Mode

The idle mode is entered by setting the IDL bit in the PCON register. In the idle mode, the internal clock to the processor is stopped. The peripherals and the interrupt logic continue to be clocked. The processor will exit idle mode when either an interrupt or a reset occurs.

#### Power-down Mode

When the PD bit of the PCON register is set, the processor enters the power-down mode. In this mode all of the clocks, including the oscillator are stopped. The only way to exit power-down mode is by a reset.

# W78L32/W78L032A/W78M032A



## Reset

The external RESET signal is sampled at S5P2. To take effect, it must be held high for at least two machine cycles while the oscillator is running. An internal trigger circuit in the reset line is used to deglitch the reset line when the W78L32 is used with an external RC network. The reset logic also has a special glitch removal circuit that ignores glitches on the reset line. During reset, the ports are initialized to FFH, the stack pointer to 07H, PCON (with the exception of bit 4) to 00H, and all of the other SFR registers except SBUF to 00H. SBUF is not reset.

## 7. ABSOLUTE MAXIMUM RATINGS

PARAMETER	SYMBOL	MIN.	MAX.	UNIT
DC Power Supply	VCC-VSS	-0.3	+7.0	V
Input Voltage	VIN	VSS-0.3	VCC+0.3	V
Operating Temperature	TA	0	70	°C
Storage Temperature	TST	-55	+150	°C

**Note:** Exposure to conditions beyond those listed under Absolute Maximum Ratings may adversely affect the life and reliability of the device.

## 8. DC CHARACTERISTICS

(VDD-VSS = 5V ±10%, TA = 25°C, Fosc = 20 MHz, unless otherwise specified.)

PARAMETER	SYM.	PECIFICATION		UNIT	TEST CONDITIONS
		MIN.	MAX.		
Operating Voltage	VDD	1.8	5.5	V	
Operating Current	IDD	-	20	mA	No load, VDD = 5.5V, 20 MHz
		-	3	mA	No load, VDD = 2.0V, 16 MHz
Idle Current	IIDLE	-	6	mA	VDD = 5.5V, Fosc = 20 MHz
		-	1.5	mA	VDD = 2.0V, Fosc = 16 MHz
Power Down Current	IPWDN	-	50	μA	VDD = 5.5V, Fosc = 20 MHz
		-	20	μA	VDD = 2.0V, Fosc = 16 MHz
Input Current P1, P2, P3	IIN1	-50	+10	μA	VDD = 5.5V VIN = 0V or VDD
Input Current RST	IIN2	-10	+300	μA	VDD = 5.5V 0 < VIN < VDD
Input Leakage Current P0, EA	ILK	-10	+10	μA	VDD = 5.5V 0V < VIN < VDD
Logic 1 to 0 Transition Current P1, P2, P3	ITL [*4]	-500	-	μA	VDD = 5.5V VIN = 2.0V



# W78L32/W78L032A/W78M032A



DC Characteristics, continued

PARAMETER	SYM.	PECIFICATION		UNIT	TEST CONDITIONS
		MIN.	MAX.		
Input Low Voltage P0, P1, P2, P3, $\overline{EA}$	VIL1	0	0.8	V	VDD = 4.5V
		0	0.5	V	VDD = 2.0V
Input Low Voltage RST	VIL2	0	0.8	V	VDD = 4.5V
		0	0.3	V	VDD = 2.0V
Input Low Voltage XTAL1 [*4]	VIL3	0	0.8	V	VDD = 4.5V
		0	0.6	V	VDD = 2.0V
Input High Voltage P0, P1, P2, P3, $\overline{EA}$	VIH1	2.4	VDD +0.2	V	VDD = 5.5V
		1.4	VDD +0.2	V	VDD = 2.0V
Input High Voltage RST	VIH2	3.5	VDD +0.2	V	VDD = 5.5V
		1.7	VDD +0.2	V	VDD = 2.0V
Input High Voltage XTAL1 [*4]	VIH3	3.5	VDD +0.2	V	VDD = 5.5V
		1.6	VDD +0.2	V	VDD = 2.0V
Output Low Voltage P1, P2, P3	VOL1	-	0.45	V	VDD = 4.5V, IOL = +2 mA
		-	0.25	V	VDD = 2.0V, IOL = +1 mA
Output Low Voltage P0, ALE, $\overline{PSEN}$ [*3]	VOL2	-	0.45	V	VDD = 4.5V, IOL = +4 mA
		-	0.25	V	VDD = 2.0V, IOL = +2 mA
Sink Current P1, P2, P3	ISK1	4	9	mA	VDD = 4.5V, Vin = 0.45V
		1.8	5.4	mA	VDD = 2.0V, Vin = 0.45V
Sink Current P0, ALE, $\overline{PSEN}$	ISK2	8	16	mA	VDD = 4.5V, Vin = 0.45V
		4.5	9	mA	VDD = 2.0V, Vin = 0.45V
Output High Voltage P1, P2, P3	VOH1	2.4	-	V	VDD = 4.5V, IOH = -100 $\mu$ A
		1.4	-	V	VDD = 2.0V, IOH = -8 $\mu$ A
Output High Voltage P0, ALE, $\overline{PSEN}$ [*3]	VOH2	2.4	-	V	VDD = 4.5V, IOH = -400 $\mu$ A
		1.4	-	V	VDD = 2.0V, IOH = -200 $\mu$ A
Source Current P1, P2, P3	ISR1	-100	-250	$\mu$ A	VDD = 4.5V, Vin = 2.4V
		-12	-30	$\mu$ A	VDD = 2.0V, Vin = 1.4V
Source Current P0, ALE, $\overline{PSEN}$	ISR2	-8	-16	mA	VDD = 4.5V, Vin = 2.4V
		-1.4	-2.4	mA	VDD = 2.0V, Vin = 1.4V

**Notes:**

- \*1. RST pin is a Schmitt trigger input.
- \*3. P0, ALE and  $\overline{PSEN}$  are tested in the external access mode.
- \*4. XTAL1 is a CMOS input.
- \*5. Pins of P1, P2, P3 can source a transition current when they are being externally driven from 1 to 0.



## 9. AC CHARACTERISTICS

The AC specifications are a function of the particular process used to manufacture the part, the ratings of the I/O buffers, the capacitive load, and the internal routing capacitance. Most of the specifications can be expressed in terms of multiple input clock periods (TCP), and actual parts will usually experience less than a  $\pm 20$  nS variation. The numbers below represent the performance expected from a 0.5 micron CMOS process when using 2 and 4 mA output buffers.

### Clock Input Waveform

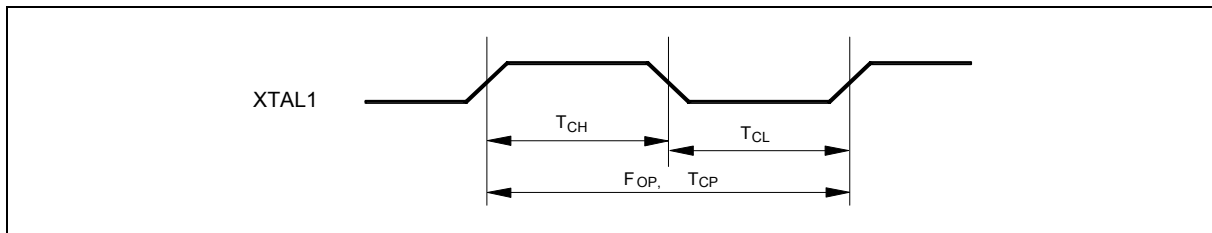

PARAMETER	SYMBOL	MIN.	TYP.	MAX.	UNIT	NOTES
Operating Speed	FOP	0	-	24	MHz	1
Clock Period	TCP	41.7	-	-	nS	2
Clock High	TCH	20	-	-	nS	3
Clock Low	TCL	20	-	-	nS	3

**Notes:**

1. The clock may be stopped indefinitely in either state.
2. The TCP specification is used as a reference in other specifications.
3. There are no duty cycle requirements on the XTAL1 input.

### Program Fetch Cycle

PARAMETER	SYMBOL	MIN.	TYP.	MAX.	UNIT	NOTES
Address Valid to ALE Low	TAAS	1 TCP- $\Delta$	-	-	nS	4
Address Hold after ALE Low	TAAH	1 TCP- $\Delta$	-	-	nS	1, 4
ALE Low to $\overline{\text{PSEN}}$ Low	TAPL	1 TCP- $\Delta$	-	-	nS	4
$\overline{\text{PSEN}}$ Low to Data Valid	TPDA	-	-	2 TCP	nS	2
Data Hold after $\overline{\text{PSEN}}$ High	TPDH	0	-	1 TCP	nS	3
Data Float after $\overline{\text{PSEN}}$ High	TPDZ	0	-	1 TCP	nS	
ALE Pulse Width	TALW	2 TCP- $\Delta$	2 TCP	-	nS	4
$\overline{\text{PSEN}}$ Pulse Width	TPSW	3 TCP- $\Delta$	3 TCP	-	nS	4

**Notes:**

1. P0.0–P0.7, P2.0–P2.7 remain stable throughout entire memory cycle.
2. Memory access time is 3 TCP.
3. Data have been latched internally prior to  $\overline{\text{PSEN}}$  going high.
4. " $\Delta$ " (due to buffer driving delay and wire loading) is 20 nS.

# W78L32/W78L032A/W78M032A



## Data Read Cycle

PARAMETER	SYMBOL	MIN.	TYP.	MAX.	UNIT	NOTES
ALE Low to $\overline{RD}$ Low	T <sub>DAR</sub>	3 T <sub>CP</sub> - $\Delta$	-	3 T <sub>CP</sub> + $\Delta$	nS	1, 2
$\overline{RD}$ Low to Data Valid	T <sub>DDA</sub>	-	-	4 T <sub>CP</sub>	nS	1
Data Hold after $\overline{RD}$ High	T <sub>DDH</sub>	0	-	2 T <sub>CP</sub>	nS	
Data Float after $\overline{RD}$ High	T <sub>DDZ</sub>	0	-	2 T <sub>CP</sub>	nS	
$\overline{RD}$ Pulse Width	T <sub>DRD</sub>	6 T <sub>CP</sub> - $\Delta$	6 T <sub>CP</sub>	-	nS	2

### Notes:

1. Data memory access time is 8 T<sub>CP</sub>.
2. " $\Delta$ " (due to buffer driving delay and wire loading) is 20 nS.

## Data Write Cycle

PARAMETER	SYMBOL	MIN.	TYP.	MAX.	UNIT
ALE Low to $\overline{WR}$ Low	T <sub>DAW</sub>	3 T <sub>CP</sub> - $\Delta$	-	3 T <sub>CP</sub> + $\Delta$	nS
Data Valid to $\overline{WR}$ Low	T <sub>DAD</sub>	1 T <sub>CP</sub> - $\Delta$	-	-	nS
Data Hold from $\overline{WR}$ High	T <sub>DWD</sub>	1 T <sub>CP</sub> - $\Delta$	-	-	nS
$\overline{WR}$ Pulse Width	T <sub>DWR</sub>	6 T <sub>CP</sub> - $\Delta$	6 T <sub>CP</sub>	-	nS

**Note:** " $\Delta$ " (due to buffer driving delay and wire loading) is 20 nS.

## Port Access Cycle

PARAMETER	SYMBOL	MIN.	TYP.	MAX.	UNIT
Port Input Setup to ALE Low	T <sub>PDS</sub>	1 T <sub>CP</sub>	-	-	nS
Port Input Hold from ALE Low	T <sub>PDH</sub>	0	-	-	nS
Port Output to ALE	T <sub>PDA</sub>	1 T <sub>CP</sub>	-	-	nS

**Note:** Ports are read during S5P2, and output data becomes available at the end of S6P2. The timing data are referenced to ALE, since it provides a convenient reference.



## 10. TIMING WAVEFORMS

### Program Fetch Cycle

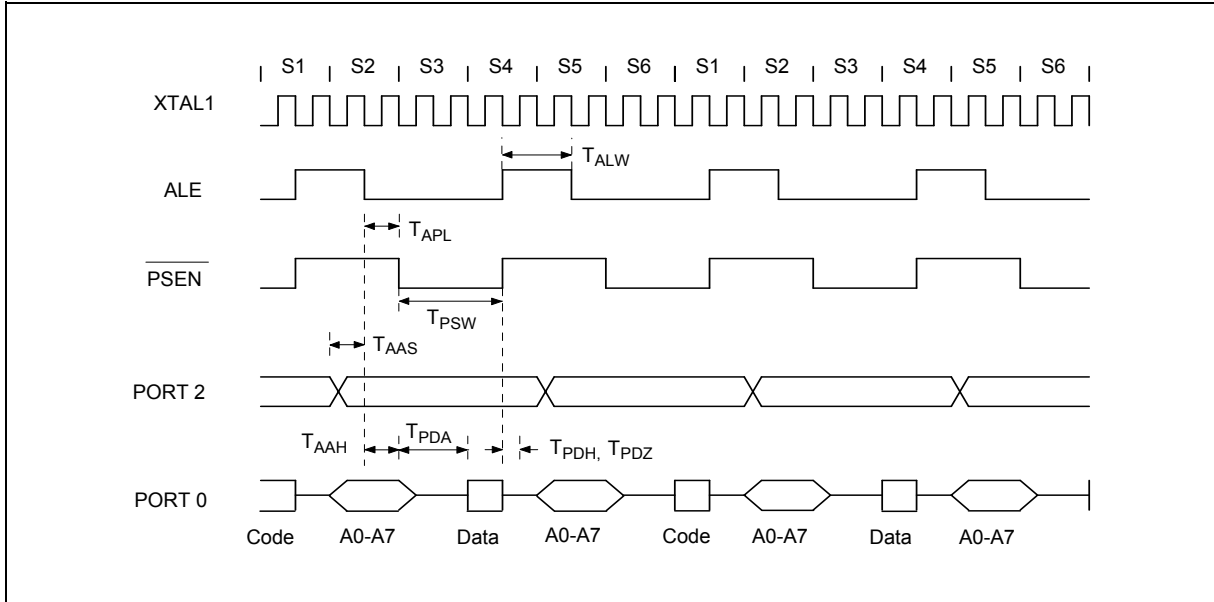

### Data Read Cycle

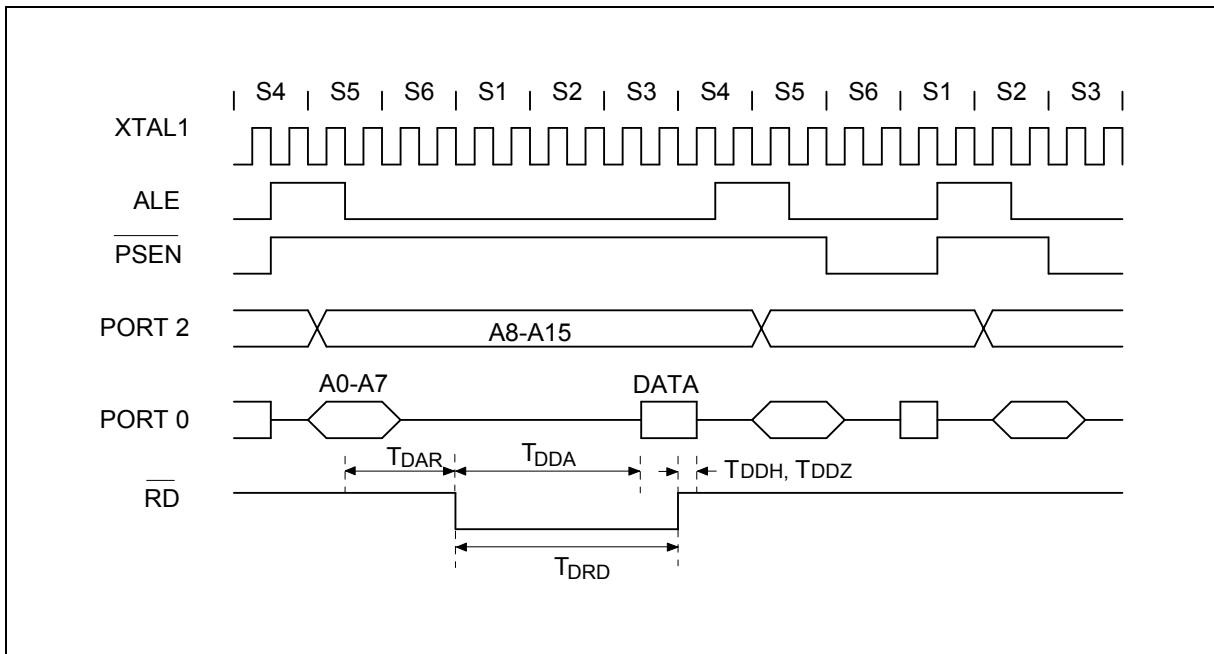

# W78L32/W78L032A/W78M032A



Timing Waveforms, continued

## Data Write Cycle

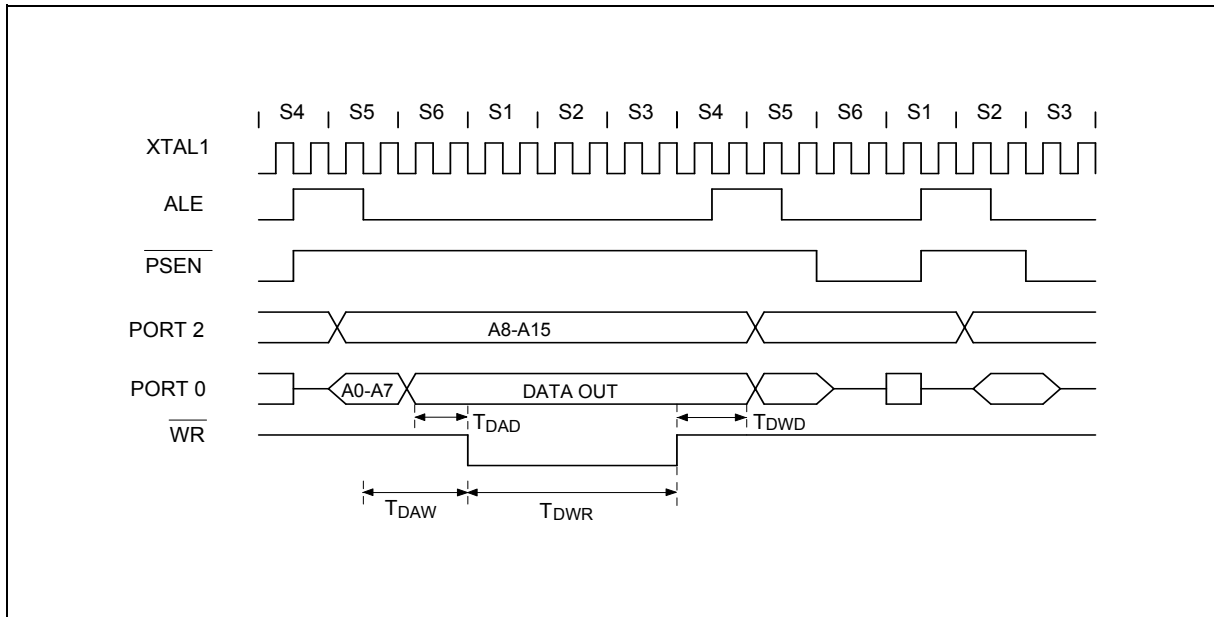

## Port Access Cycle

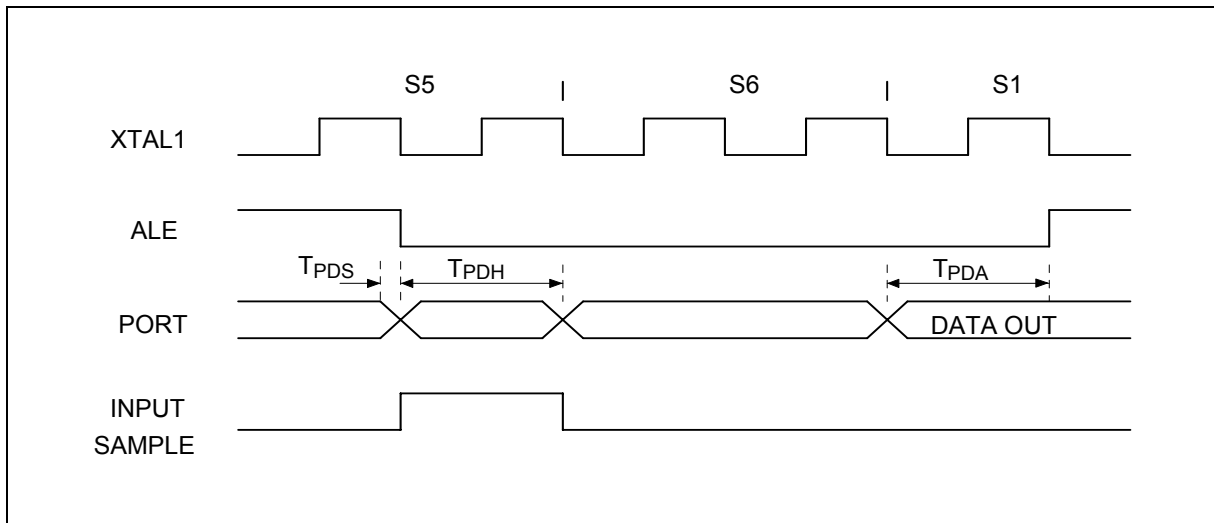

# W78L32/W78L032A/W78M032A



## 11. TYPICAL APPLICATION CIRCUITS

### Using External Program Memory and Crystal

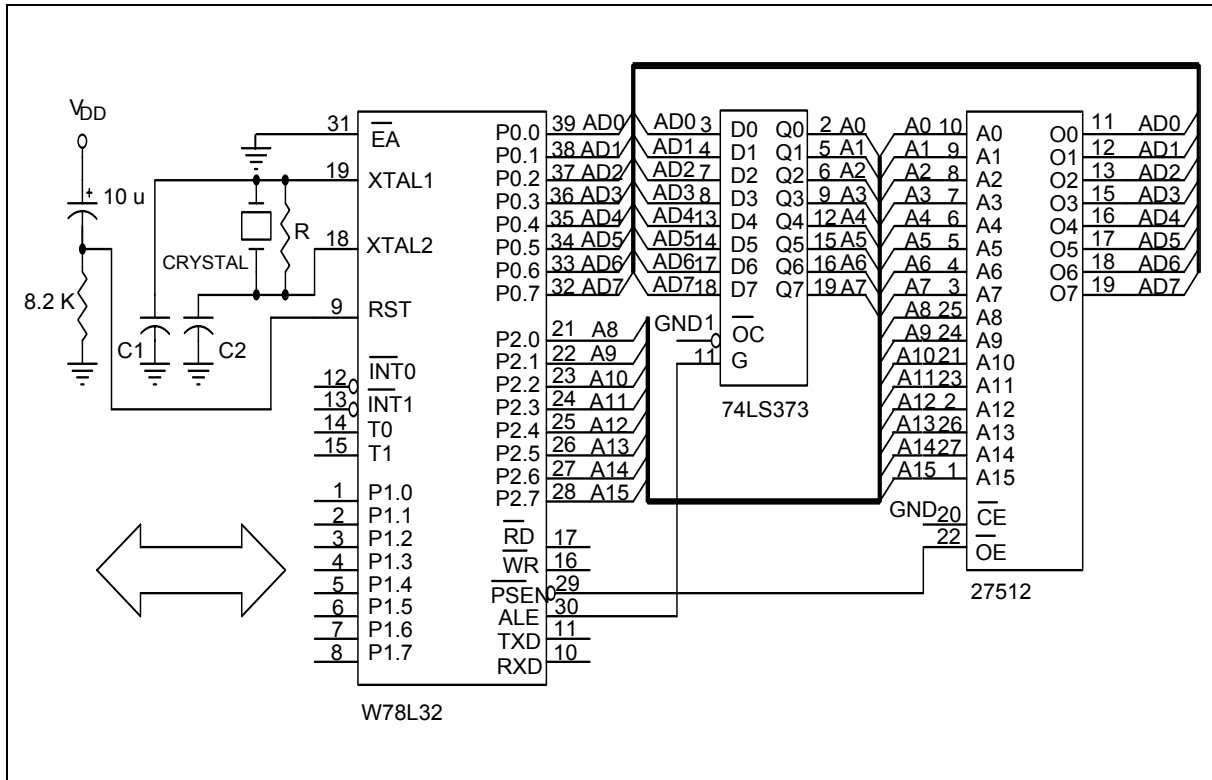

Figure A

CRYSTAL	C1	C2	R
16 MHz	30P	30P	-
24 MHz	15P	15P	-

Above table shows the reference values for crystal applications.

**Note:** C1, C2, R components refer to Figure A.

# W78L32/W78L032A/W78M032A



Typical Application Circuits, continued

## Expanded External Data Memory and Oscillator

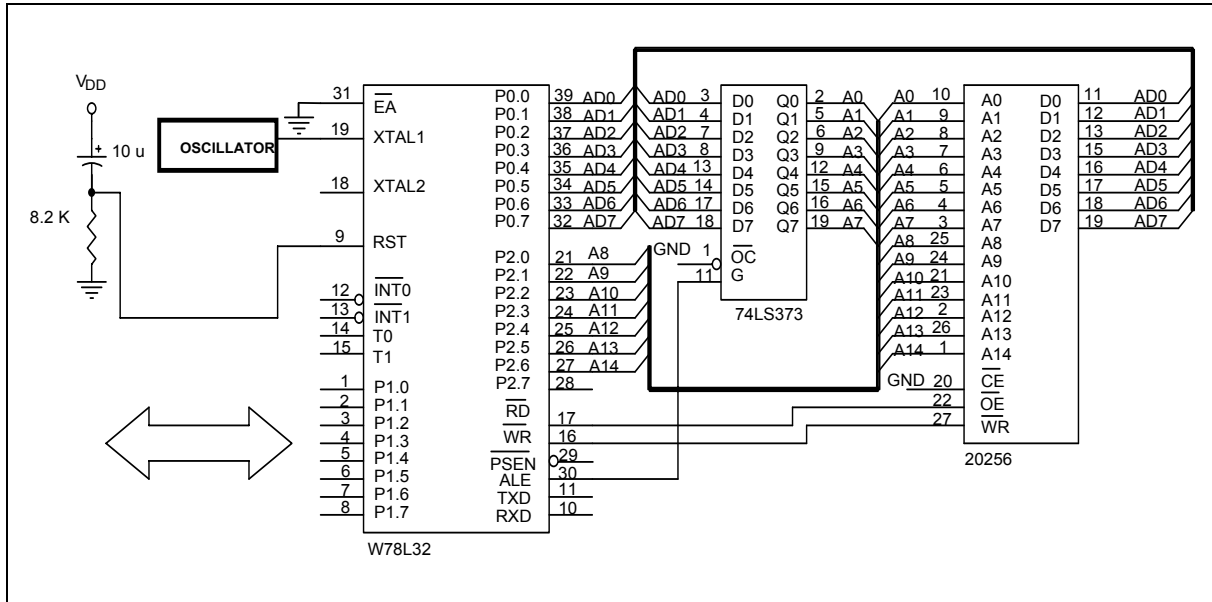

Figure B

# W78L32/W78L032A/W78M032A



## 12. PACKAGE DIMENSIONS

### 40-pin DIP

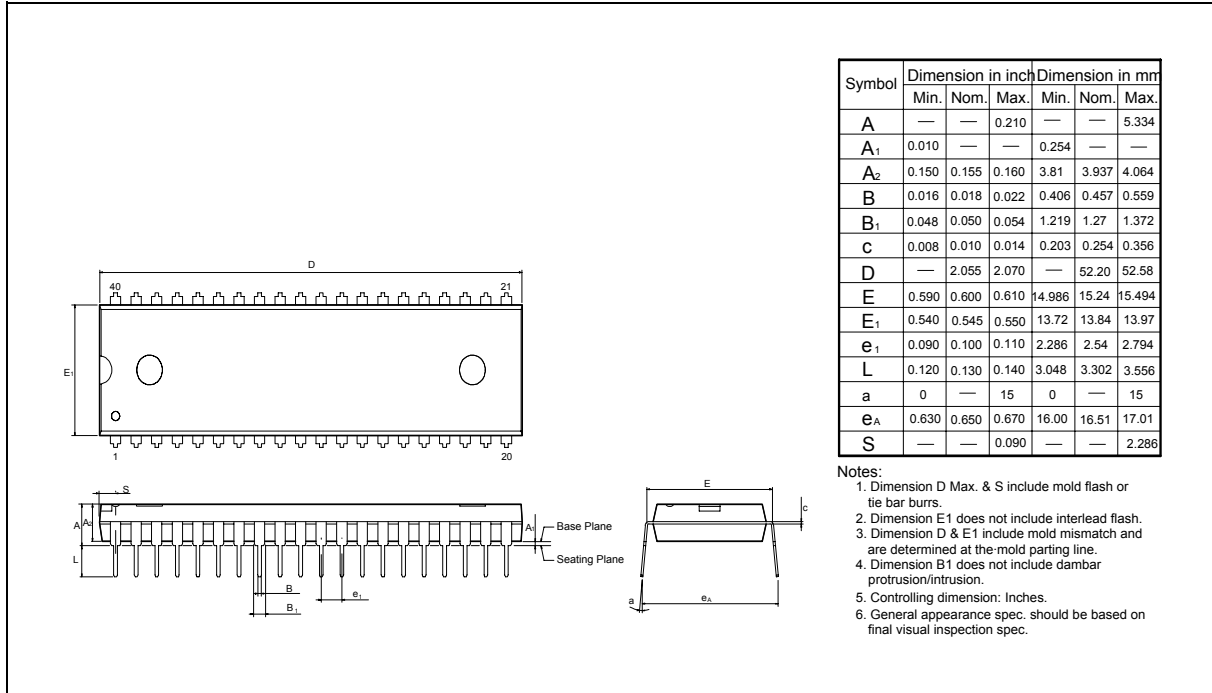

### 44-pin PLCC

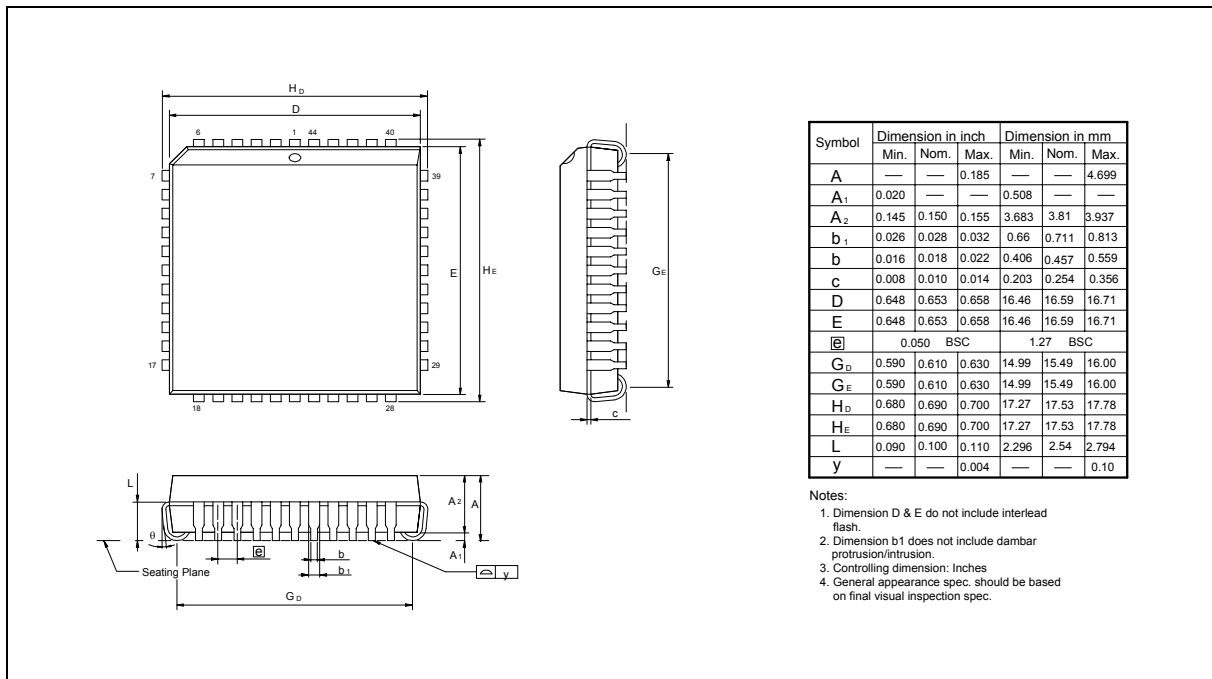



# W78L32/W78L032A/W78M032A



Package Dimensions, continued

## 44-pin QFP

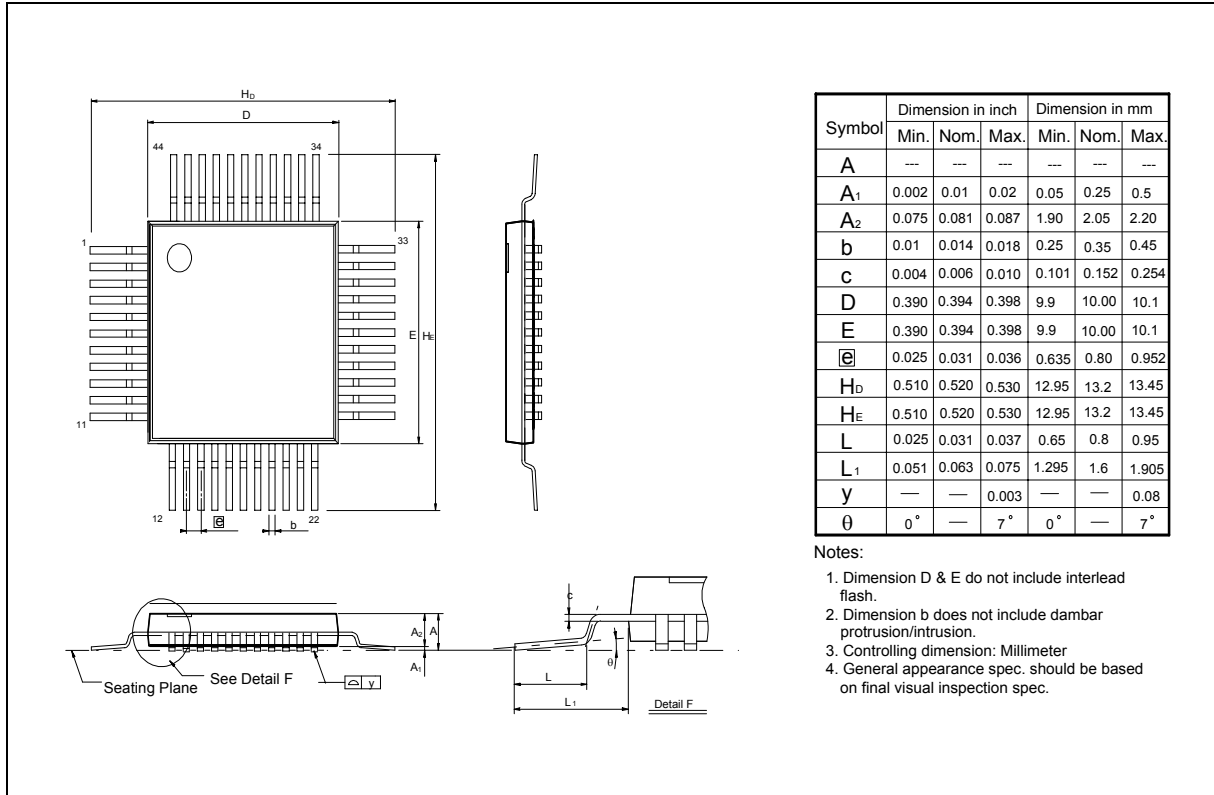



## 13. REVISION HISTORY

VERSION	DATE	PAGE	REASONS FOR CHANGE
A2	October 2000		-
A3	April 20, 2005	16	Add Important Notice
A4	December 21, 2005	2	Add lead-free(RoHS) parts
A5	March 7, 2006	2	Add 2nd lead-free(RoHS) parts

### Important Notice

Winbond products are not designed, intended, authorized or warranted for use as components in systems or equipment intended for surgical implantation, atomic energy control instruments, airplane or spaceship instruments, transportation instruments, traffic signal instruments, combustion control instruments, or for other applications intended to support or sustain life. Further more, Winbond products are not intended for applications wherein failure of Winbond products could result or lead to a situation wherein personal injury, death or severe property or environmental damage could occur.

Winbond customers using or selling these products for use in such applications do so at their own risk and agree to fully indemnify Winbond for any damages resulting from such improper use or sales.



#### Headquarters

No. 4, Creation Rd. III,  
Science-Based Industrial Park,  
Hsinchu, Taiwan  
TEL: 886-3-5770066  
FAX: 886-3-5665577  
<http://www.winbond.com.tw/>

#### Taipei Office

9F, No.480, Rueiguang Rd.,  
Neihu District, Taipei, 114,  
Taiwan, R.O.C.  
TEL: 886-2-8177-7168  
FAX: 886-2-8751-3579

#### Winbond Electronics Corporation America

2727 North First Street, San Jose,  
CA 95134, U.S.A.  
TEL: 1-408-9436666  
FAX: 1-408-5441798

#### Winbond Electronics Corporation Japan

7F Daini-ueno BLDG, 3-7-18  
Shinyokohama Kohoku-ku,  
Yokohama, 222-0033  
TEL: 81-45-4781881  
FAX: 81-45-4781800

#### Winbond Electronics (Shanghai) Ltd.

27F, 2299 Yan An W. Rd. Shanghai,  
200336 China  
TEL: 86-21-62365999  
FAX: 86-21-62365998

#### Winbond Electronics (H.K.) Ltd.

Unit 9-15, 22F, Millennium City,  
No. 378 Kwun Tong Rd.,  
Kowloon, Hong Kong  
TEL: 852-27513100  
FAX: 852-27552064

*Please note that all data and specifications are subject to change without notice.  
All the trade marks of products and companies mentioned in this data sheet belong to their respective owners.*