

| REVISIONS | | | | | |
|-----------|-----|---------------------|-----------|------|-------|
| REV | ECO | DESCRIPTION | DATE | BY | APPR |
| A1 | -- | RELEASE NEW DRAWING | 16/NOV/22 | MILO | TOMMY |

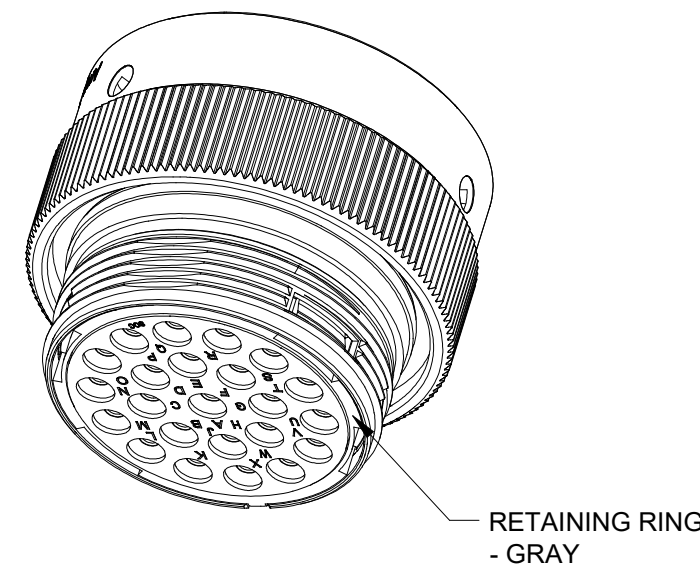
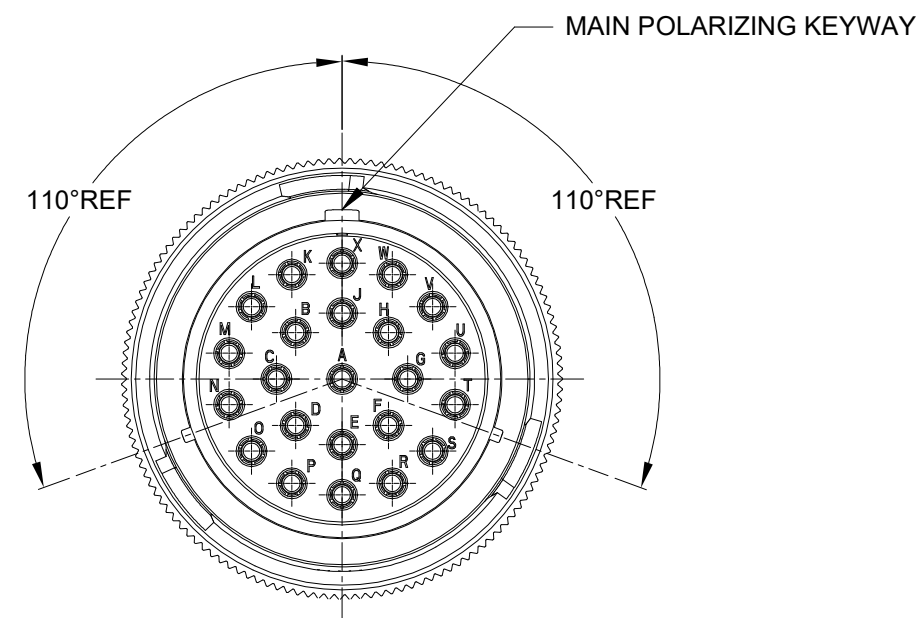
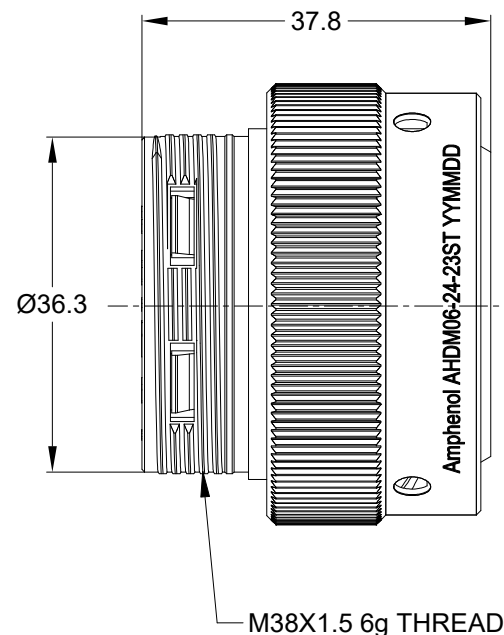
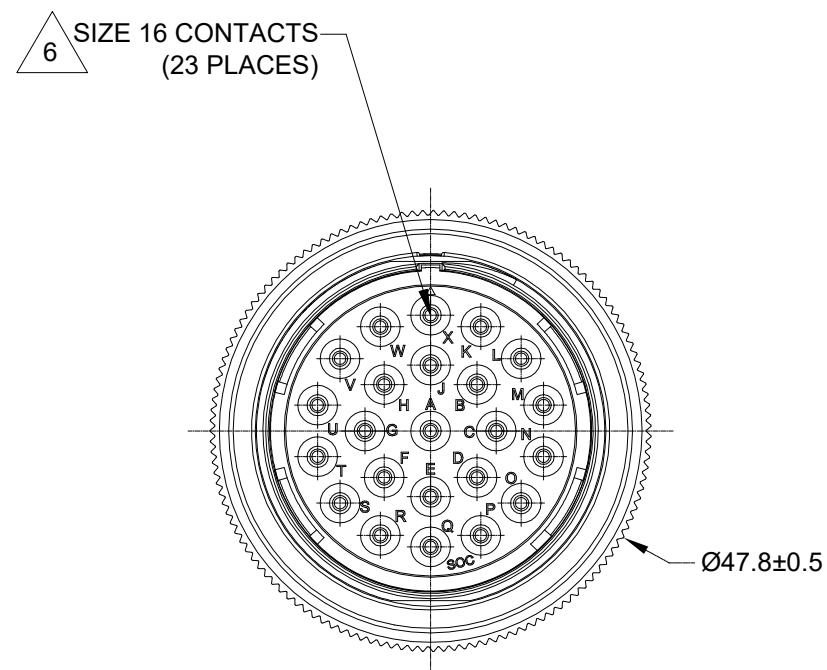

NOTES: UNLESS OTHERWISE SPECIFIED

- MATERIAL:
SHELL: ZINC ALLOY, NICKEL PLATED
COUPLING RING: ALUMINUM ALLOY, NICKEL PLATED
INSERT AND RETAINING RING: THERMOPLASTIC
SEAL: SILICONE RUBBER
- MODIFICATIONS: THREADED HOUSING; THIN WALL DIA. WIRE SEAL
- SPECIFICATIONS:
 - OPERATING TEMPERATURE: -55°C TO +125°C.
 - DIELECTRIC WITHSTANDING VOLTAGE: LESS THAN 2 MILLIAMPS CURRENT LEAKAGE @ 1500 VOLTS AC.
 - INSULATION RESISTANCE: 1000 MEGOHM MIN @ 25°C.
 - MOISTURE RESISTANCE:
IP68(IM OF WATER FOR A PERIOD OF 24 HOURS, MATED CONDITION);
IP69K(MATED CONDITION)
 - MATING CYCLE DURABILITY: 100 CYCLES
 - RoHS COMPLIANT
- MATING PART: AHDM04-24-23P* (* = SEAL TYPE)
- ALL DIMENSIONS ARE FOR REFERENCE USE ONLY.

6 CONTACT SIZE AND WIRE RANGE:

| CONTACT SIZE | MIN.INSUL O.D | MAX.INSUL O.D | WIRE RANGE mm ² |
|--------------|-----------------|-----------------|------------------------------------|
| 16 | 2.23mm (.088in) | 2.69mm (.106in) | 14-20AWG (2.0-0.5mm ²) |

TITLE: 23POS,PLUG,SOCKET,SZ24,THIN WIRE SEAL,AHDM

DWG NO: AHDM06-24-23ST

REV: A1

SH: 1

OF: 1

| QUANTITY | AHDM06-24-23ST | DESCRIPTION | ITEM | | | | | | | | |
|--------------------------------------|-------------------|--|-----------------|------|------|---------|----------|---|----|----------------|----|
| | REF: HD36-24-23ST | | | | | | | | | | |
| | PART NUMBER | DESCRIPTION | ITEM | | | | | | | | |
| MATERIALS LIST | | | | | | | | | | | |
| UNLESS OTHERWISE SPECIFIED | | SIGNATURES | | | | | | | | | |
| 1) All dimensions are in metric(mm). | | DRAWN: MILO.DONG | DATE: 16/NOV/22 | | | | | | | | |
| 2) Tolerances are as follows: | | CHECKED: SULLENZHANG | DATE: 17/NOV/22 | | | | | | | | |
| 1 PL DEC ±0.30 | | ENGINEER: | | | | | | | | | |
| 2 PL DEC ±0.15 | | APPROVAL: TOMMY.XIE | DATE: 18/NOV/22 | | | | | | | | |
| 3 PL DEC ±0.08 | | CUSTOMER: | | | | | | | | | |
| 3) Note reference = X | | <p style="text-align: center;">Amphenol</p> <p style="text-align: center;">Sine Systems - www.amphenol-sine.com 44724 Morley Drive Clinton Township, MI 48036</p> | | | | | | | | | |
| MATERIAL SPECIFICATIONS: | | 23POS,PLUG,SOCKET,SZ24, THIN WIRE SEAL,AHDM | | | | | | | | | |
| WEIGHT: 89.0g | | <table border="1"> <tr> <th>SIZE</th> <th>TYPE</th> <th>DWG NO:</th> <th>REVISION</th> </tr> <tr> <td>B</td> <td>C-</td> <td>AHDM06-24-23ST</td> <td>A1</td> </tr> </table> | | SIZE | TYPE | DWG NO: | REVISION | B | C- | AHDM06-24-23ST | A1 |
| SIZE | TYPE | DWG NO: | REVISION | | | | | | | | |
| B | C- | AHDM06-24-23ST | A1 | | | | | | | | |
| PROCESS SPECIFICATIONS: | | THIS DRAWING IS SUPPLIED FOR INFORMATION ONLY. DESIGN FEATURES, SPECIFICATIONS AND PERFORMANCE DATA SHOWN HEREON ARE THE PROPERTY OF THE AMPHENOL CORPORATION. NO RIGHTS OF REPRODUCTION ARE IMPLIED. ALL DIMENSIONS ARE SUBJECT TO NORMAL MANUFACTURING VARIATIONS. | | | | | | | | | |
| NEXT ASSY: | | SCALE: NONE DURAMATE SHEET 1 OF 1 | | | | | | | | | |