

DESCRIPTION: FEMALE - DIP SOLDER - HIGH PROFILE

DIMENSIONS

No. OF PINS	A	B	C	D	E	F	G
9	1.213	0.984	0.642	0.315	0.618	0.496	0.429
	30.80	24.99	16.30	8.00	15.70	12.60	10.90
15	1.541	1.312	0.969	0.315	0.933	0.496	0.429
	39.15	33.32	24.60	8.00	23.70	12.60	10.90
25	2.088	1.852	1.512	0.315	1.496	0.496	0.429
	53.04	47.04	38.40	8.00	38.00	12.60	10.90
37	2.729	2.500	2.157	0.315	2.142	0.496	0.429
	69.32	63.50	54.80	8.00	54.40	12.60	10.90
50	2.635	2.406	2.059	0.425	2.039	0.602	0.535
	66.93	61.11	52.30	10.80	51.80	15.30	13.60

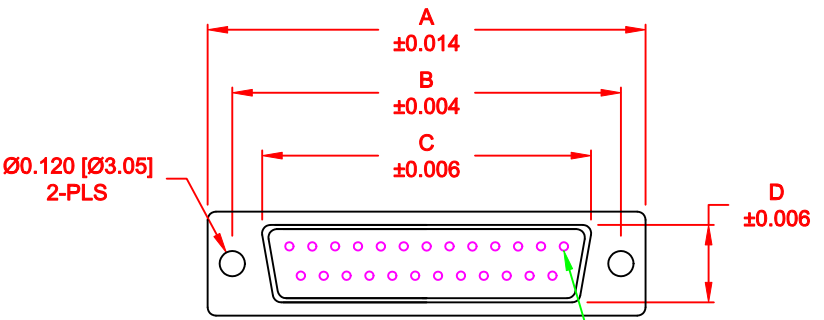

3 ROWS →

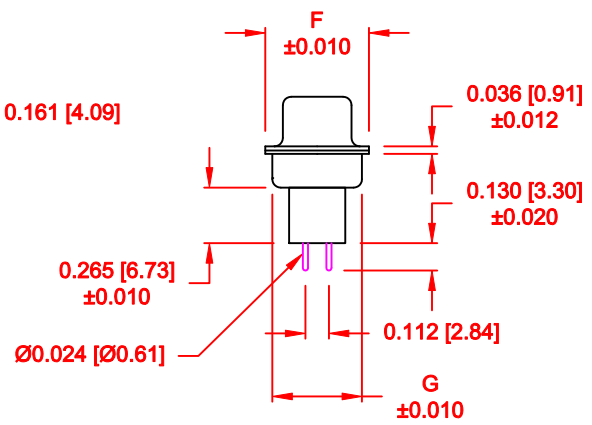
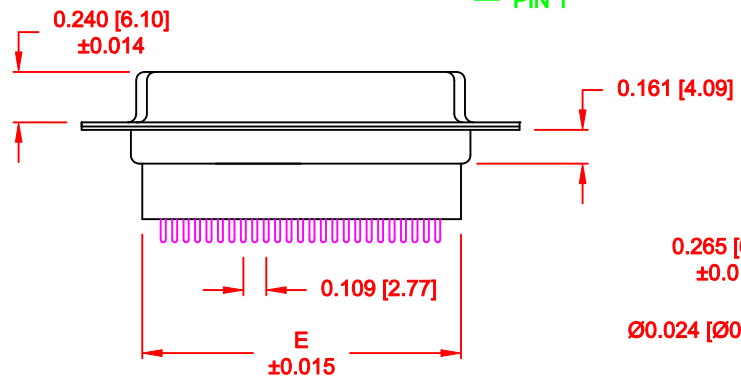

172-YYY-281LYY1

- SERIES _____
- POSITIONS _____
- 009 _____
- 015 _____
- 025 _____
- 037 _____
- 050 _____
- GENDER _____
- 2 = FEMALE
- TERMINATION _____
- 8 = HIGH PROFILE VERTICAL
- SHELL PLATING _____
- 1 = YELLOW CHROMATE (NON-ROHS)
- HARDWARE OPTIONS _____
- 00 = NO HARDWARE
- 01 = .098" CLINCH NUT (BOARD SIDE)
- 02 = .236" CLINCH NUT (BOARD SIDE)
- 03 = .236" CLINCH NUT (MATING SIDE)
- PLATING OPTIONS _____
- 1 = GOLD FLASH
- 2 = 30u" GOLD

MATERIAL:

- SHELL: STEEL, YELLOW CHROMATE
- INSULATOR: UL 94V-O RATED, PBT-BLACK
- PROCESS TEMP.: 230°C
- CONTACTS: BRASS - GOLD PLATED

ELECTRICAL:

- CURRENT RATING: 5 AMPS
- CONTACT RESISTANCE: 15 mOhms Max.
- INSULATION RESISTANCE: 1,000 MOhms min.
- VOLTAGE: 500VAC FOR 1 MINUTE
- TEMPERATURE: -50° C TO 125° C

DO NOT SCALE FROM DRAWING

	THESE DRAWINGS AND SPECIFICATIONS ARE THE PROPERTY OF NorComp AND SHALL NOT BE REPRODUCED, COPIED OR USED AS THE BASIS FOR THE MANUFACTURE OF SALE OF APPARATUS WITHOUT WRITTEN PERMISSION.		DRAWN: WAYNE ROBBINS	DATE: 08-23-98
			CHECKED:	DATE:
NorComp		SCALE: 1 : 1	SHEET 1 OF 3	REV 1
		DWG NO. 172-YYY-281LYY1		

DESCRIPTION: PCB LAYOUT - STANDARD "D" - MALE & FEMALE

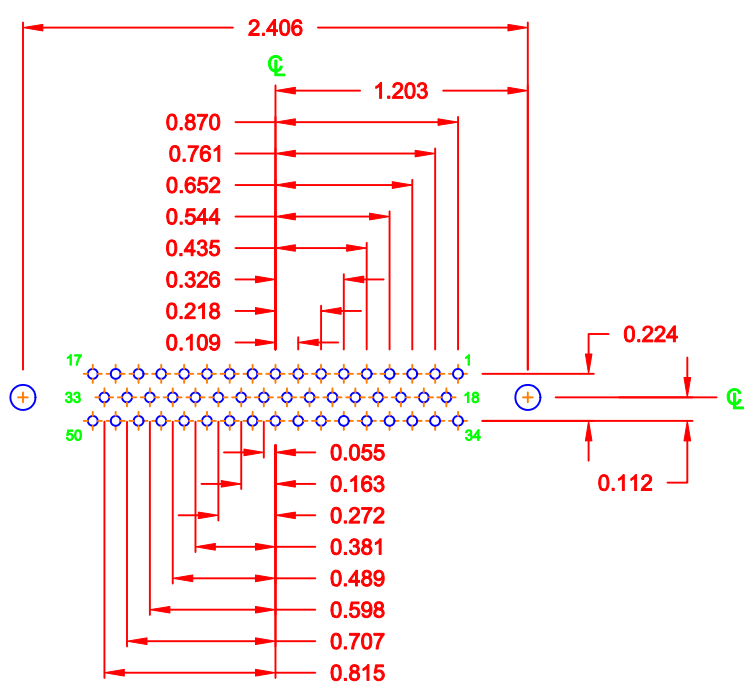
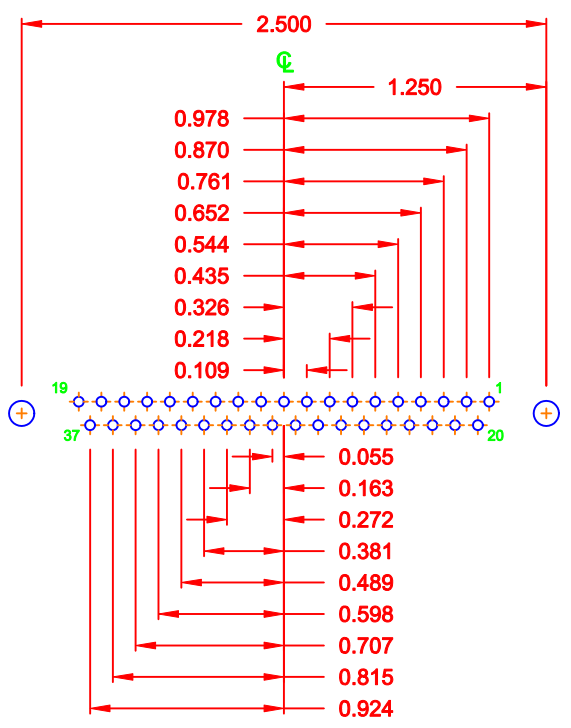
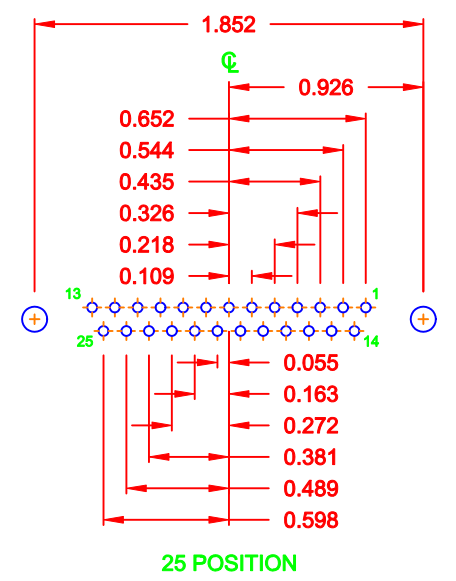
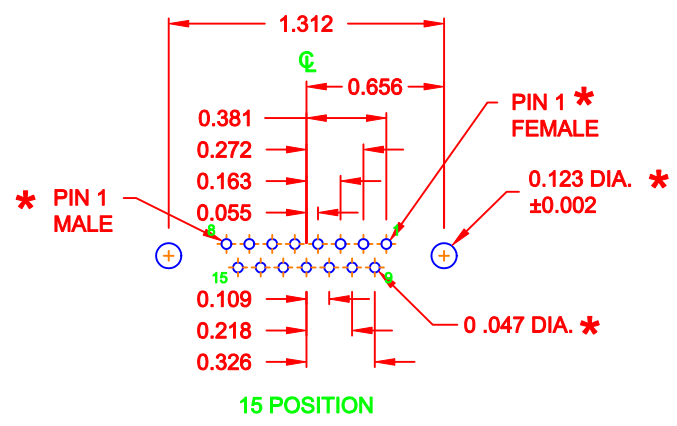
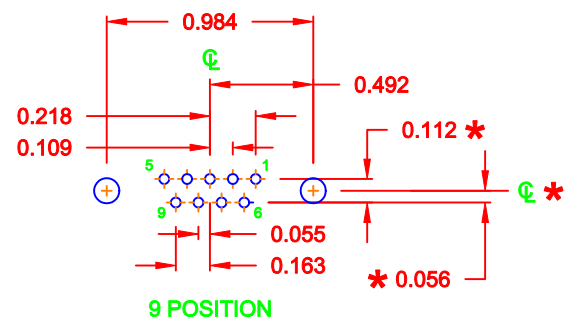

* TYP. ON ALL SIZES

DO NOT SCALE FROM DRAWING

	THESE DRAWINGS AND SPECIFICATIONS ARE THE PROPERTY OF NorComp AND SHALL NOT BE REPRODUCED, COPIED OR USED AS THE BASIS FOR THE MANUFACTURE OF SALE OF APPARATUS WITHOUT WRITTEN PERMISSION.		DRAWN: C. SMITH	DATE: 03-08-06
			CHECKED:	DATE:
NorComp		SCALE: FULL	SHEET 2 OF 3	REV 1
		DWG NO. 172-YYY-281LYY1		

DESCRIPTION: CLINCH NUT HARDWARE

TOLERANCE:
ALL DIMENSIONS ARE ± 0.010

ALL CLINCH-NUTS ARE 4-40 INTERNAL THREADS

01X 0.065" (BOARD SIDE) - CN1

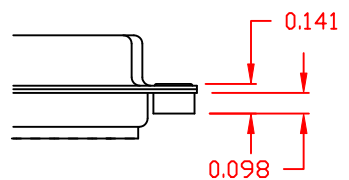

02X 0.236" (BOARD SIDE) - CN2

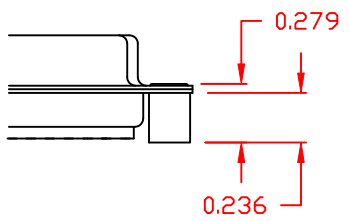

03X..... 0.236" (MATING SIDE) - CN8

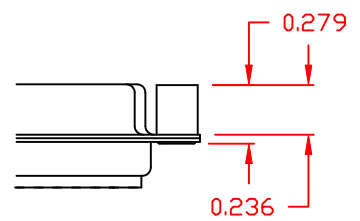

DO NOT SCALE FROM DRAWING

	THESE DRAWINGS AND SPECIFICATIONS ARE THE PROPERTY OF NorComp AND SHALL NOT BE REPRODUCED, COPIED OR USED AS THE BASIS FOR THE MANUFACTURE OF SALE OF APPARATUS WITHOUT WRITTEN PERMISSION.		DRAWN: WAYNE ROBBINS	DATE: 11-28-05
			CHECKED:	DATE:
NorComp		SCALE:	SHEET 3 OF 3	REV 1
		DWG NO. 172-YYY-281LYY1		