

TE CONNECTIVITY (TE) RESERVES THE RIGHT TO CHANGE THIS DRAWING AT ANYTIME. USERS SHOULD EVALUATE THE SUITABILITY OF THE PRODUCT FOR THEIR APPLICATION.	REVISION			
	LTR	DESCRIPTION	DATE	APPROVED
	C	REVISED PER ECO-15-001168	01/23/2015	I. MYONG
	C1	REVISED PER ECO-15-002628	02/18/2015	I. MYONG

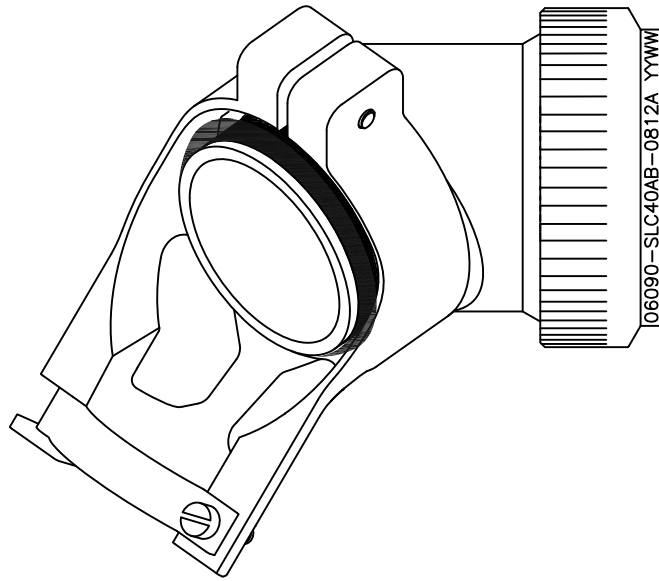

## CODE 40 – SPIN-LOCK ADAPTER WITH STRAIN RELIEF FITTING

### NOTES:

1. THIS PRODUCT IS DESIGNED TO TERMINATE A BRAIDED CABLE SHIELD TO A CONNECTOR AND PROVIDE STRAIN RELIEF.
2. SEE DRAWING "TR" FOR DETAIL ON TINEL-LOCK RING. RINGS ARE DESIGNED TO BE HEATED ELECTRICALLY. ALL RINGS ARE MARKED WITH THERMOCHROMIC PAINT WHICH CHANGES COLOR WHEN INSTALLATION TEMPERATURE IS REACHED.
3. ADAPTER TO BE PERMANENTLY MARKED WITH CODE IDENT. NO. AND PART NO. LESS RING DESIGNATOR (e.g. 06090-SLC40AB-1216A YYWW).
4. ADAPTER MATES TO MIL-DTL-38999, SERIES III & IV, CLASS C, F, K, AND W; D38999/20/24, /26, /40, /46, /47 CONNECTORS.
5. INSTALLATION PROCEDURE MIP-103-1.
6. PERFORMANCE SPECIFICATION MPS-103.
7. FOR ADDITIONAL ORDERING INFORMATION, REFER TO CH00-0250-019.

If this document is printed it becomes uncontrolled. Check for the latest revision

©2015 TE CONNECTIVITY LTD. FAMILY OF COMPANIES. ALL RIGHTS RESERVED  
 TE CONNECTIVITY AND TE CONNECTIVITY (LOGO) ARE TRADEMARKS.  
 OTHER LOGOS PRODUCT AND/OR COMPANY NAMES MAY BE TRADEMARKS OF THEIR RESPECTIVE OWNERS.

Raychem Adapters  
 CUSTOMER DRAWING

UNLESS OTHERWISE SPECIFIED DIMENSIONS ARE IN INCHES. REFERENCE METRIC DIMENSIONS ARE IN BRACKETS [metric].	DRAWN: D. JAIN	DATE: 08/08/2011		TE Connectivity			
	CHECKED: B. WONG	DATE: 08/08/2011					
DECIMALS TOLERANCES: XXX ± .005 [0.13mm] XX ± .01 [0.25mm] X ± .1 [0.50mm] ANGLES TOLERANCE: ± 1°	APPROVED: I. MYONG	DATE: 12/11/2014	TITLE: CODE 40 – SPIN-LOCK ADAPTER				
	MATERIAL: SEE NOTES	FINISH: SEE NOTES					
SCALE: DO NOT SCALE THIS DRAWING	CAD FILE: SLC40.dwg	THIRD ANGLE PROJECTION: 	SIZE: A	SHEET: 1 OF 3	CAGE CODE: 06090	DRAWING NO: SLC40	REV. C1

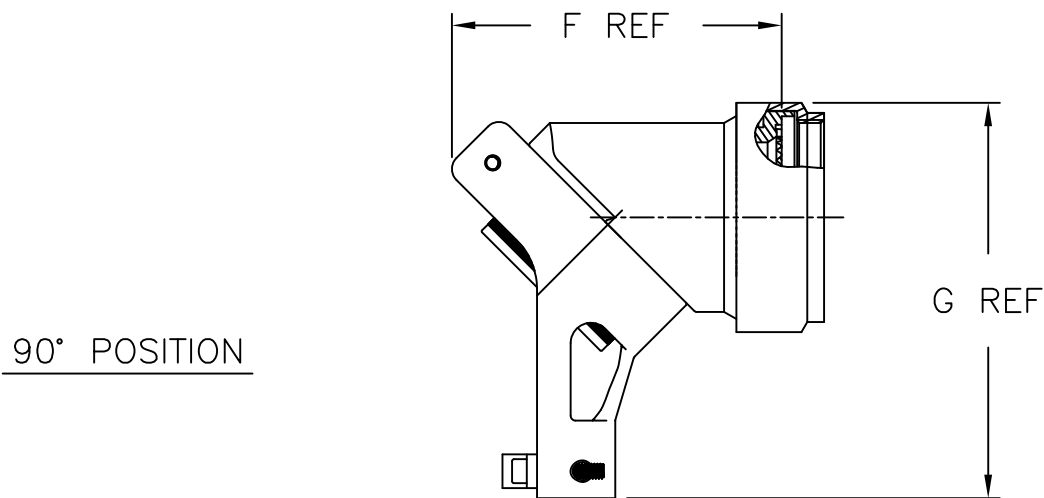
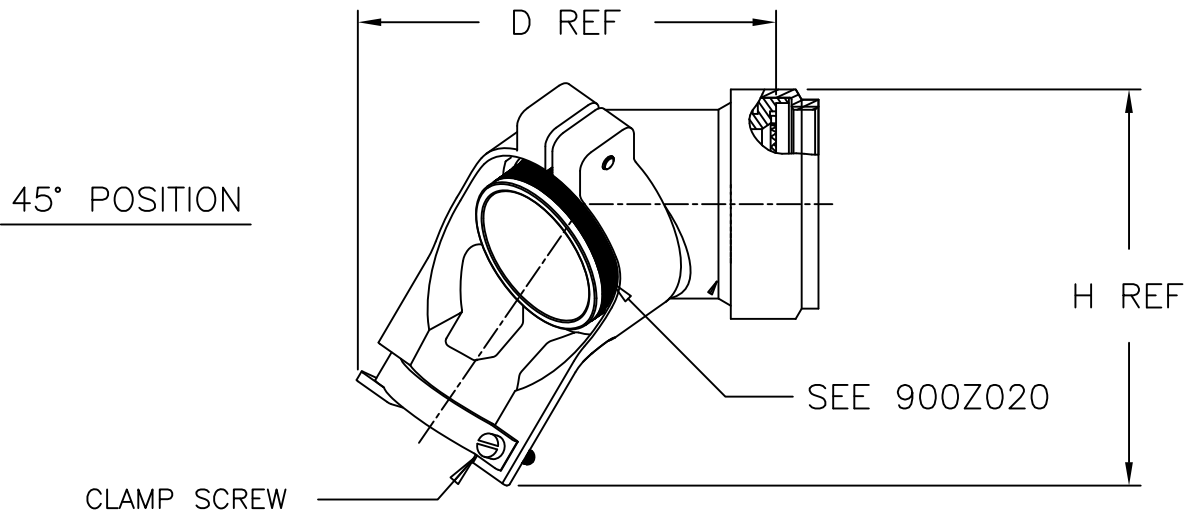
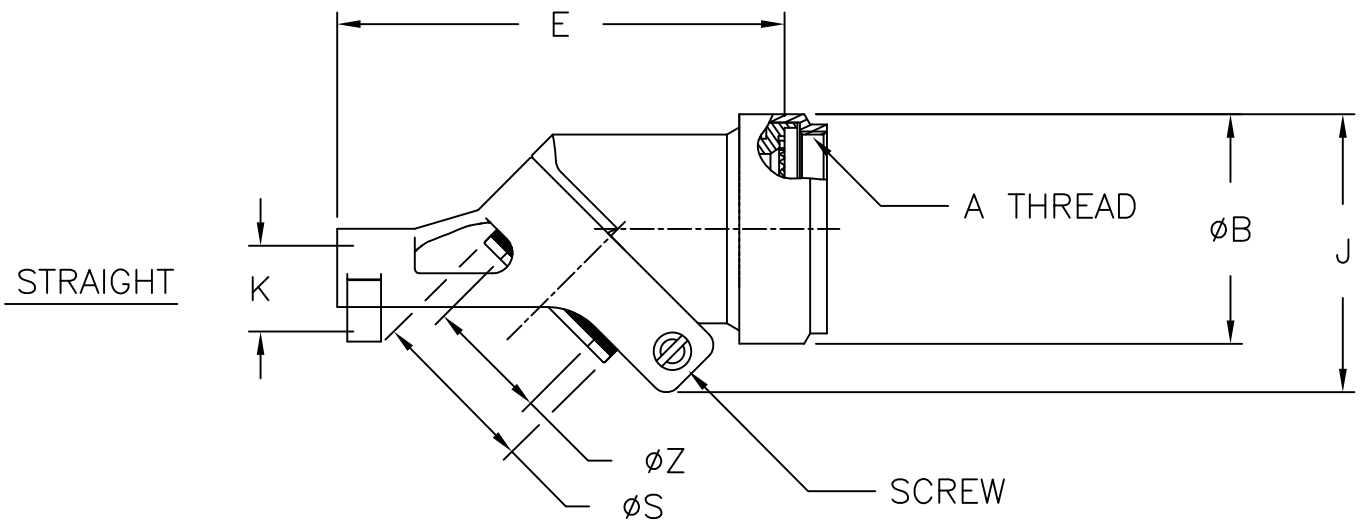

Raychem Adapters  
CUSTOMER DRAWING

If this document is printed it becomes uncontrolled. Check for the latest revision

	DO NOT SCALE THIS DRAWING	SIZE	CAGE	SHEET	DWG. NO.	REV
		A	06090	2 OF 3	SLC40	C1

TABLE I

ORDER NO.	SHELL SIZE 4		AVAILABLE ENTRY SIZES (SEE TABLE III)			A THREAD CLASS 6H	ØB MAX
	COM'L	MIL	S	L	XL		
08	09	A	-	-	04	M12 x 1.0	.75 (19.05)
10	11	B	-	04	06	M15 x 1.0	.85 (21.59)
12	13	C	04	06	08	M18 x 1.0	1.00 (25.40)
14	15	D	06	08	10	M22 x 1.0	1.15 (29.21)
16	17	E	08	10	12	M25 x 1.0	1.25 (31.75)
18	19	F	10	12	14	M28 x 1.0	1.40 (35.56)
20	21	G	10	12	16	M31 x 1.0	1.50 (38.10)
22	23	H	12	14	18	M34 x 1.0	1.65 (41.91)
24	25	J	12	16	20	M37 x 1.0	1.75 (44.45)

TABLE II

ORDER NO.	D REF	E MAX	F REF	G REF	H REF	K MAX	J MAX
08	1.88 (47.8)	1.90 (48.3)	1.37 (34.8)	1.66 (42.2)	1.80 (45.7)	.234 (5.94)	1.09 (27.7)
10	2.00 (50.8)	2.05 (52.1)	1.47 (37.3)	1.83 (46.5)	1.86 (47.2)	.234 (5.94)	1.20 (30.5)
12	2.04 (51.8)	2.18 (55.4)	1.54 (39.1)	1.95 (49.5)	1.94 (49.3)	.328 (8.45)	1.26 (32.0)
14	2.30 (58.4)	2.38 (60.5)	1.79 (45.5)	2.07 (52.6)	2.11 (53.6)	.457 (11.61)	1.43 (36.3)
16	2.44 (62.0)	2.53 (64.3)	1.93 (49.0)	2.24 (56.9)	2.28 (57.9)	.614 (15.60)	1.58 (40.1)
18	2.59 (65.8)	2.76 (70.1)	2.21 (56.1)	2.47 (62.7)	2.55 (64.8)	.634 (16.10)	1.75 (44.5)
20	2.70 (68.6)	2.81 (71.4)	2.18 (55.4)	2.56 (65.0)	2.67 (67.8)	.698 (17.73)	1.89 (48.0)
22	2.89 (73.4)	3.15 (80.0)	2.29 (58.2)	2.90 (73.7)	2.96 (75.2)	.823 (20.90)	1.99 (50.5)
24	2.96 (75.2)	3.25 (82.6)	2.39 (60.7)	2.96 (75.2)	3.04 (77.2)	.853 (21.67)	2.10 (53.3)

TABLE III

ENTRY SIZE	ØS	ØZ +.010 (0.25) -.020 (0.50)
04	.376 (9.55) .370 (9.40)	.250 (6.35)
06	.501 (12.73) .495 (12.57)	.375 (9.53)
08	.626 (15.90) .619 (15.72)	.500 (12.70)
10	.752 (19.10) .742 (18.85)	.625 (15.88)
12	.877 (22.28) .867 (22.02)	.750 (18.84)
14	1.002 (25.45) .991 (25.17)	.875 (22.23)
16	1.127 (28.63) 1.116 (28.35)	1.000 (25.40)
18	1.252 (31.80) 1.241 (31.52)	1.125 (28.58)
20	1.377 (34.98) 1.366 (34.70)	1.250 (31.75)

If this document is printed it becomes uncontrolled. Check for the latest revision

Raychem Adapters  
CUSTOMER DRAWINGDO NOT  
SCALE THIS  
DRAWINGSIZE  
ACAGE  
06090SHEET  
3 OF 3

DWG. NO.

SLC40

REV  
C1