

Switching Power Supply Type SPD 120W DIN rail mounting

CARLO GAVAZZI



- Installation on DIN Rail 7.5 or 15mm
- Short circuit protection
- PFC available
- High efficiency
- Power ready output
- LED indicator for DC power ON
- LED indicator for DC low
- Parallel versions available
- Compact dimensions
- UL, cUL listed and TUV/CE approved

Product Description

The Switching power application where the installation is on a DIN rail and compact dimensions and performance are a must.

Ordering Key

SP D 24 120 1 BFP

Model _____
 Mounting (D= Din rail) _____
 Output voltage _____
 Output power _____
 Input Type _____
 Optional features _____

Input type: 1= single phase

Approvals



Optional Features

Description	Code
Plug-in connectors	Bxx
With P.F.C.	xFx
With Parallel function	xxP

Output Performances

MODEL NO.	INPUT VOLTAGE	OUTPUT WATTAGE	OUTPUT VOLTAGE	OUTPUT CURRENT	EFF. (min.)	EFF. (typ.)
Single Output Models						
SPD12	1ø 90~264 VAC	120 WATTS	+12 VDC	10 A	85%	87%
SPD24	1ø 90~264 VAC	120 WATTS	+24 VDC	5 A	87%	94%

Output Data

Line regulation	± 1%	Voltage fall time ($I_o, \text{nom } V_i \text{ nom}$)	150ms max
Load regulation	±1%	Rated continuous loading	
Minimum load	0A	12V Model	10A @ 12VDC/8.2A @ 14.5VDC
Turn on time (full resistive load)		24V Model	5A @ 24VDC/4.2A @ 28.5VDC
VI nom, Io nom	1000ms	Reverse voltage	
VI nom, Io nom 12V model with 3500 µF CAP	1500ms	12V Model	VDC 18
VI nom, Io nom 24V models with 7000 µF CAP	1500ms	24V Model	VDC 35
Transient recovery time	2ms	Capacitor load	
Ripple and noise	100mVpp	VI nom Io nom 12V model	7000µF
Output voltage accuracy	±1%	VI nom Io nom 24V model	3500µF
Temperature coefficient	±0.03%/°C	Voltage rise time	
Hold up time Vi	20ms	VI nom Io nom	500ms
Voltage fall time ($I_o, \text{nom } V_i \text{ nom}$)	150ms max	VI nom, Io nom 12V model with 7000µF CAP	500ms
		24V model with 3500µF CAP	500ms

Input Data

Rated input voltage	115/230 (auto selected)		Power dissipation		
Voltage range			12V Model	20W	
AC 115V selected	90 - 132VAC		24V Model	16W	
AC 220V selected	180 - 264VCA		Frequency range	47-63Hz	
DC	210 - 315VDC		Leakage current		
Rated input current			Input-Output	0.25mA	
(Vi:90VAC, Io nom)	Typ.	0.36A	Input-FG	3.5mA	
	Max.	0.5A			
Inrush current					
	Vi= 115VAC	10A			

Controls and Protections

Overload	110-145%	Over voltage protection	VDC	
Input fuse	T2A/600VAC internal ¹⁾		Min.	Max.
Output short circuit	Hiccup mode	12V Model	14.5	17.4
Power ready output on threshold	≥17.6-19.4VDC	24V Model	30	33
Electrical isolation	500VDC	Internal surge voltage protection	Varistor	
Contact rating at 60VDC	0.3A	(IEC 61000-4-5)		

¹⁾ Fuse not replaceable by user

General Data (@ nominal line, full load, 25°C)

Ambient temperature	-35°C to +71°C	MTB (Bellcore issue 6 @ 40°C, GB)		
Derating (>61°C to +71°C)	2.5%/C	12V Model	527000 Hours	
Ambient humidity	20 - 90% RH	24V Model	559000 Hours	
Storage	-40°C to +85°C	Case material	Metal	
Protection degree	IP20	Dimensions LxWxD mm(inch)	124(4.88) x 64.4(2.53) x 118.8(4.68)	
Cooling	Free air convection	Weight	800 g	
Pollution degree	2			

Norms and Standards

Vibration resistance	meet IEC 60068-2-6 (Mounting by rail: 10-500Hz, 2G, along X, Y, Z each Axis, 60 min for each Axis)	CCC	GB4943, GB9254, GB17625.1
Shock resistance	meet IEC 60068-2-27 (15G, 11ms, 3 Axis, 6 faces, 3 times for each face)	CE	EN 61000-6-3, EN 55022 Class B, EN 61000-3-2, EN 61000-3-3, EN 61000-6-2, EN 55024, EN 61000-4-2 Level 4, EN 61000-4-3 Level 3, EN 61000-4-4 Level 4, EN 61000-4-5 Level 3, L/N-FG Level 4, EN 61000-4-6 Level 3, EN 61000-4-8 Level 4, EN 61000-4-11, ENV 50204 Level 2, EN 61204-3
UL/cUL	UL508 listed, UL60950-1, Recognized, ISA 12.12.01 (Class 1, Division 2, Groups A, B, C and D)		
TUV	EN 60950-1, CB scheme EN 61558-1, EN 61558-2-17 (meet EN 60204)		

Block Diagram

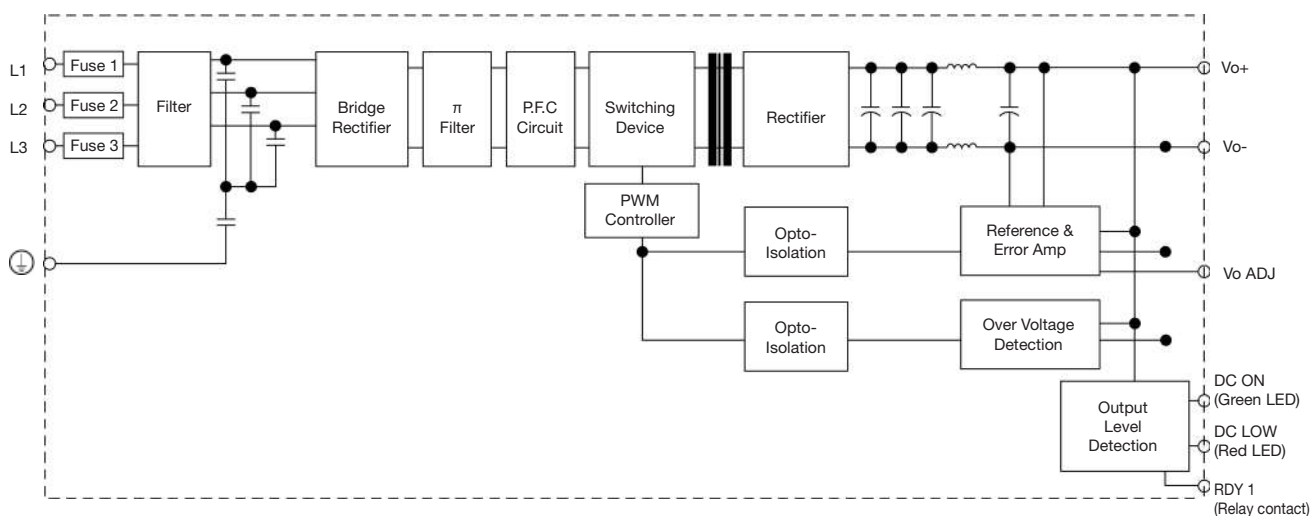

Pin Assignment and Front Controls

Pin No.	Designation	Description
1, 2	V-	Negative output terminal
3, 4	V+	Positive output terminal
5	RDY	A normal open relay contact for DC ON level control
6	RDY	(Never connect except 24V model)
7		Ground this terminal to minimize high-frequency emissions
8	L1	Input terminals
9	L2	Input terminals
10	L3	Input terminals
	DC ON	Operation indicator LED
	DC LO	DC LOW voltage indicator LED
	Vout ADJ	Trimmer-potentiometer for Vout adjustment

Derating Diagram

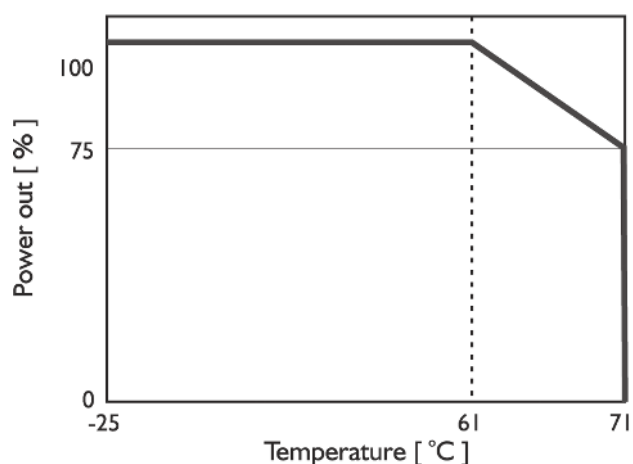

Typ. Efficiency Curve

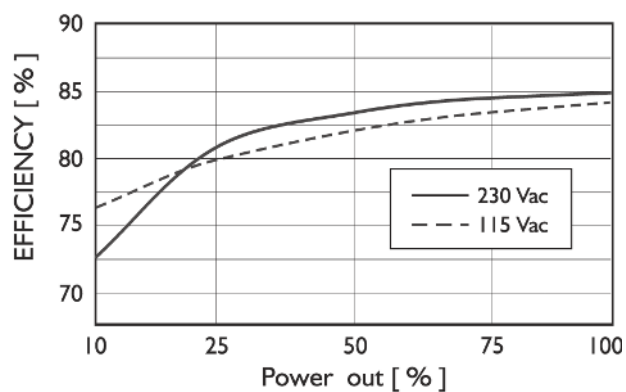

Typ. Current Limited Curve

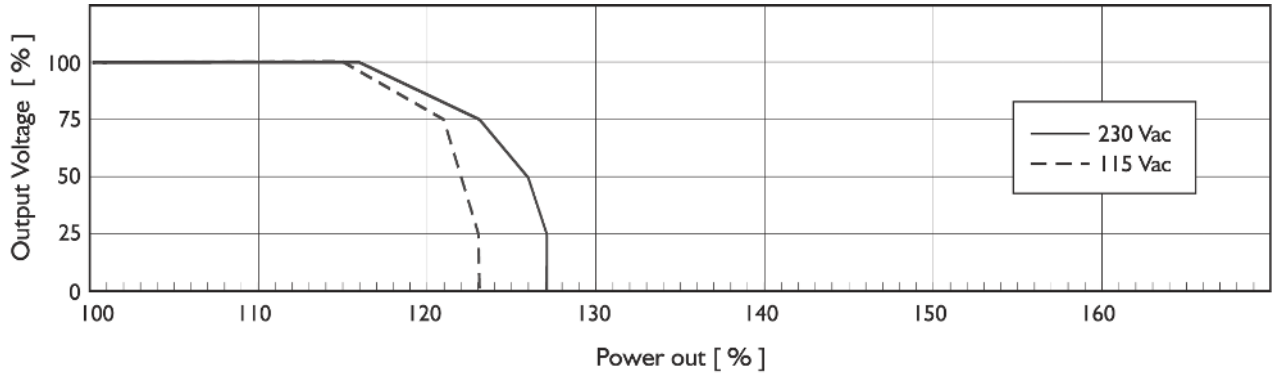

Mechanical Drawings mm (inches)

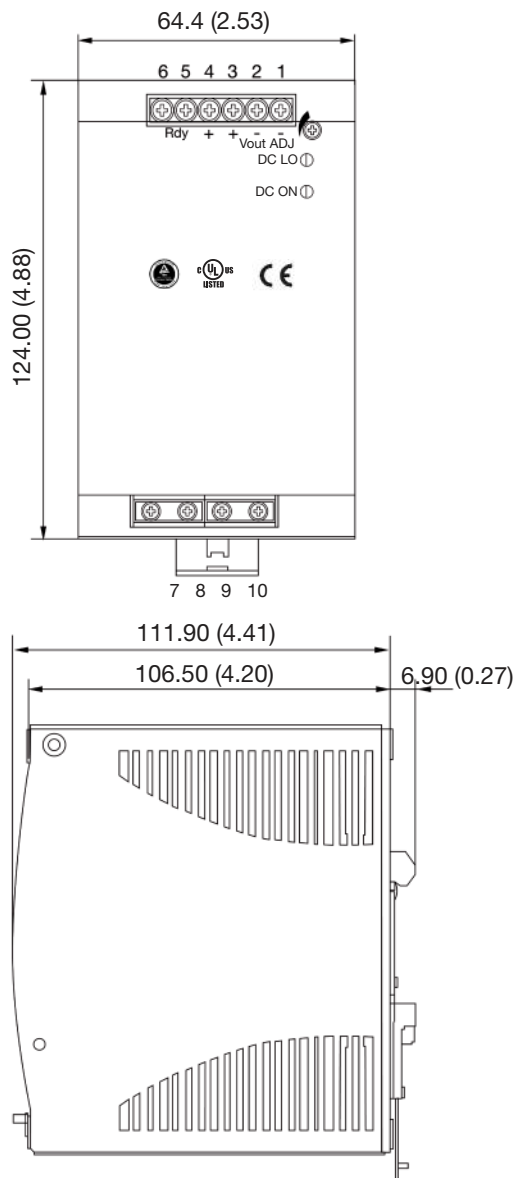

Installation

Ventilation and cooling

Normal convection All sides 25mm free space for cooling is recommended.

Screw terminal

10-24AWG flexible or solid cable 8mm stripping recommend.

Max. torque for terminal

Input terminal

1.008Nm (9.0lb-in)

Output terminal

0.616Nm (5.5lb-in)

Plug-in terminals

10-24AWG flexible or solid cable 7mm stripping recommend.

Max. torque for plug-in terminals

Input terminal

0.784Nm (7.0lb-in)

Output terminal

0.784Nm (7.0lb-in)