

1.5MHz, 600mA Synchronous Step-Down Converter

FEATURES

- High Efficiency - Up to 95%
- Guaranteed 600mA Output Current
- 2.5V to 5.5V Input Voltage Range
- 1.5MHz Constant Frequency Operation
- No external Schottky Diode Needed
- Adjustable Output Voltages From 0.6V to VIN
- Fixed Output Voltage Options Available
- 100% Duty Cycle Low-Dropout Operation
- 0.1µA Shutdown Current
- SOT23-5 Package

TYPICAL APPLICATIONS

- Cellular phones
- Blue Tooth Headsets
- Portable Audio Players
- Mobile Phones
- Wireless and DSL Modems
- Digital Still Cameras
- Portable Instruments
- Mp3 Player

DESCRIPTION

The FT440 is a 1.5MHz constant frequency, slope compensated current mode step down converter. Capable of delivering 600mA output current over a wide input voltage from 2.5V to 5.5V, the FT440 is ideally suited for single Li-Ion battery powered application.

The FT440 integrates a main switch and a synchronous rectifier for high efficiency without an external Schottky diode. The FT440 automatically turns off the synchronous rectifier to increase efficiency while enters discontinuous PWM mode.

The FT440 can run at 100% duty cycle for low dropout operation, maximizing battery life in portable application. FT440 consumes less than 1uA when enter shutdown mode.

The FT440 is available in a fixed output voltages of 1.5V, 1.8V, and 2.5V, and is also available in an adjustable output voltage version capable of generating output voltages from 0.6V to VIN .The FT440 is available in a 5-pin SOT23-5 package.

TYPICAL APPLICATION CIRCUIT

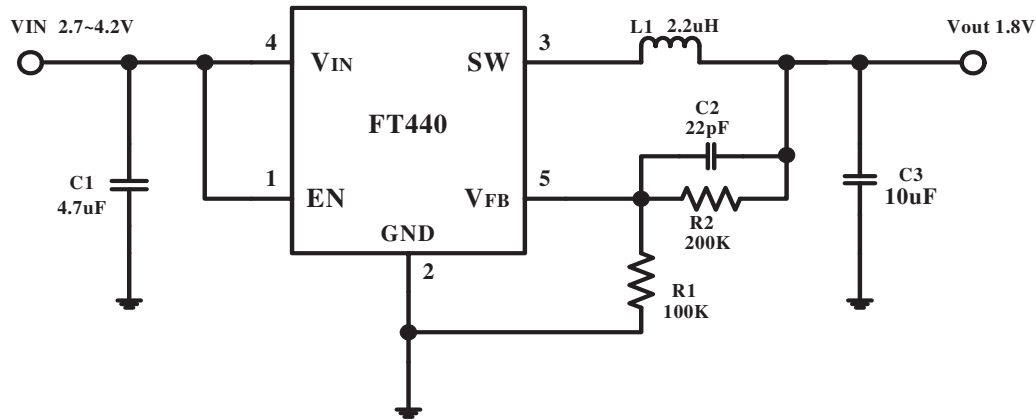

Figure 1: Typical Application Circuit

ABSOLUTE MAXIMUM RATINGS

VIN to GND.....	-0.3V to 6V
EN to GND.....	-0.3V to (VIN+0.3)
VFB to GND.....	-0.3V to (VIN+0.3)
SW to GND.....	-0.3V to (VIN+0.3)
Peak SW Sink and Source Current.....	Internally Limited
Junction to Ambient Thermal Resistance (θ_{JA}).....	250°C/W
Operating Temperature Range.....	-40°C to +85°C
Junction Temperature.....	-40°C to +150°C
Storage Temperature Range	-55°C to +150°C
Lead Temperature (Soldering, 10sec)	300°C

Stresses exceeding Maximum Ratings may damage the device. Maximum Ratings are stress ratings only. Functional operation above the Recommended Operating Conditions is not implied. Extended exposure to stresses above the Recommended Operating Conditions may affect device reliability.

PIN COMFIGURATION

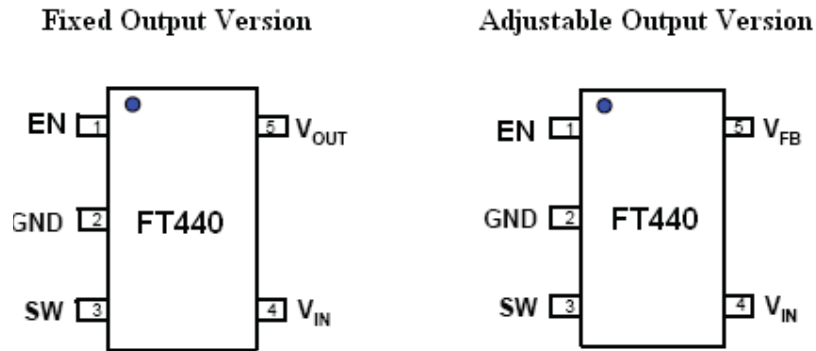

SOT23-5

Figure 2: Package Top View

TERMINAL DEFINITION

Pin	Name	Description
1	EN	Enable control input
2	GND	Ground
3	SW	Switching node, connecting to inductor
4	V _{IN}	Power input
5	V _{FB} /V _{out}	Feedback node. V _{FB} for adjustable version, and V _{out} for fixed output version

Table 1

ORDERING INFORMATION

FT440①②

Designator	Symbol	Output Voltage
①	A	ADJ
	B	1.5V
	C	1.8V
	D	2.5V
	E	1.2V
	F	2.8V
	G	3.3V
Designator	Symbol	Marking Rule
②	a	Marking Rule a
	b	Marking Rule b

Table 2

MARKING RULE a

Part Number	Top Mark	Output Voltage
FT440Aa	1AaXY	ADJ
FT440Ba	1BaXY	1.5V
FT440Ca	1CaXY	1.8V
FT440Da	1DaXY	2.5V
FT440Ea	1EaXY	1.2V
FT440Fa	1FaXY	2.8V
FT440Ga	1GaXY	3.3V

Table 3

MARKING RULE b

Part Number	Top Mark	Output Voltage
FT440Ab	A1XY	ADJ
FT440Bb	A2XY	1.5V
FT440Cb	A3XY	1.8V
FT440Db	A4XY	2.5V
FT440Eb	A5XY	1.2V
FT440Fb	A6XY	2.8V
FT440Gb	A7XY	3.3V

Table 4

BLOCK DIAGRAM

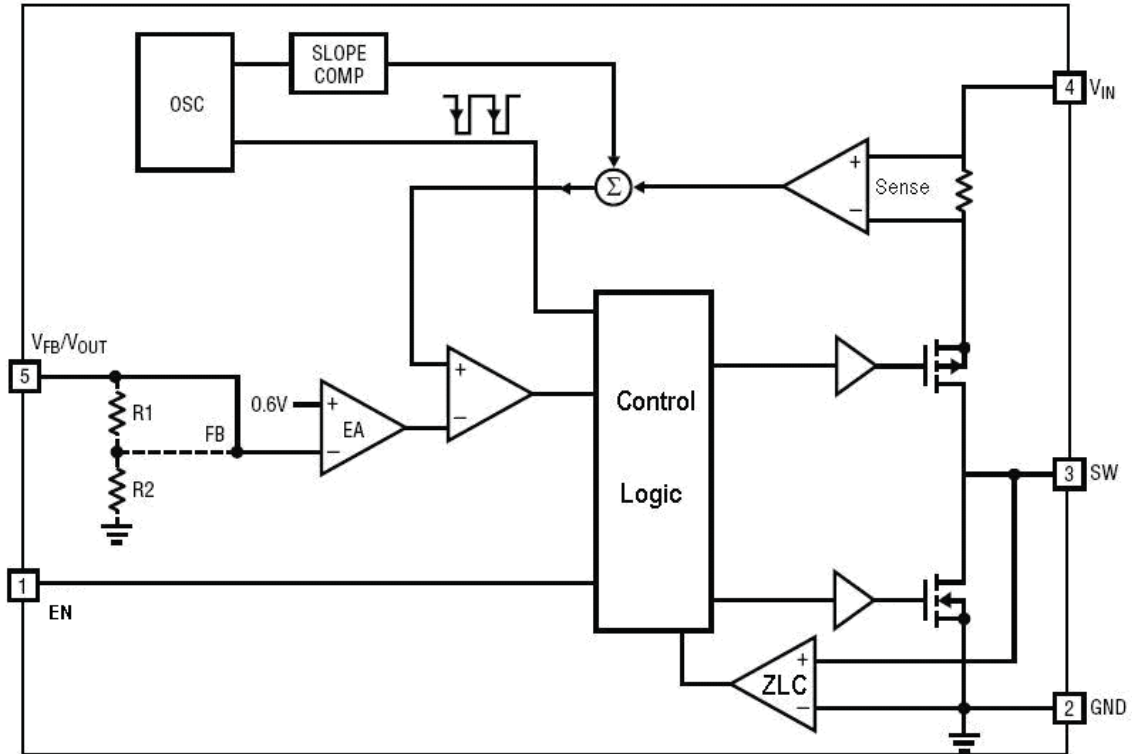

Figure 4: FT440 Block Diagram

ELECTRICAL CHARACTERISTICS

($V_{IN} = V_{EN} = 3.6V$, $T_A = 25^\circ C$ unless otherwise specified.)

Parameter	Symbol	Test Conditions	Min	Typ	Max	Unit
Input Voltage Range	V_{IN}		2.5		5.5	V
Under Voltage Lockout Threshold	V_{UVLO}	V_{IN} rising	2.2	2.35	2.5	V
Operating Supply Current		$V_{FB}=0.5$ or $V_{out}=90\%$		300	450	μA
Shutdown Supply Current		$V_{EN} = 0V$, $V_{IN} = 4.2V$		0.1	1	μA
Adjustable Version Regulation Voltage	V_{FB}	$T_A = 25^\circ C$	0.588	0.6	0.612	V
		$0 < T_A < 85^\circ C$	0.585	0.6	0.615	
		$-40^\circ C < T_A < 85^\circ C$	0.582	0.6	0.618	
Fixed Output Regulation Voltage	V_{OUT}	FT440Ba / FT440Bb	1.455	1.5	1.545	V
		FT440Ca / FT440Cb	1.746	1.8	1.854	
		FT440Da / FT440Db	2.425	2.5	2.575	
		FT440Ea / FT440Eb	1.164	1.2	1.236	
		FT440Fa / FT440Fb	2.716	2.8	2.884	
		FT440Ga / FT440Gb	3.2	3.3	3.4	
Output Voltage Line Regulation		$V_{IN} = 2.5V$ to $5.5V$		0.04	0.4	%/V
Output Voltage Load Regulation		$I_{OUT} = 0mA$ to $600mA$		0.5		%
Inductor Current Limit	I_{LIM}	$V_{IN} = 3.6V$, $V_{FB} = 0.5V$ or $V_{out} = 90\%$	0.85	1.1	1.35	A
Oscillator Frequency	f_{SW}	$V_{FB} = 0.6$ or $V_{out} = 100\%$	1.2	1.5	1.8	MHz
		$V_{FB} = 0$ or $V_{out} = 0$		400		KHz
PMOS On Resistance	R_{ONP}	$I_{SW} = -100mA$		0.36	0.5	Ω
NMOS On Resistance	R_{ONN}	$I_{SW} = 100mA$		0.33	0.45	Ω
SW Leakage Current		$EN = 0$, $V_{IN} = 5.5V$, $V_{SW} = 5.5V$ or $0V$			1	μA
EN Threshold	V_{IH}	$V_{IN} = 2.5V$ to $5.5V$	0.3	1	1.5	V
EN Leakage Current	I_{EN}	$V_{IN} = 5.5V$, $EN = V_{IN}$		0.01	1	μA

Table 5

TYPICAL PERFORMANCE CHARACTERISTICS

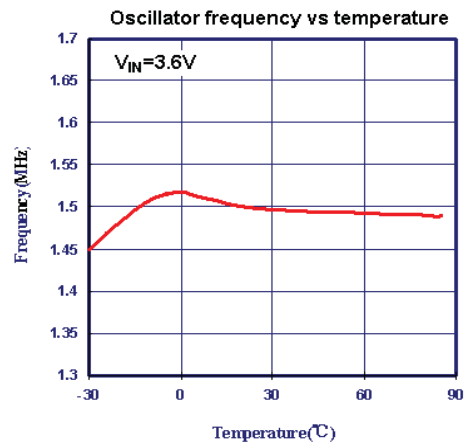
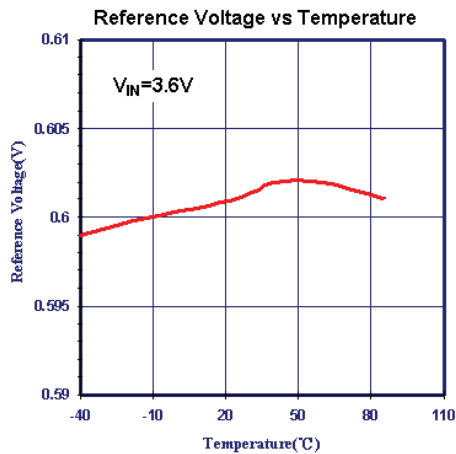
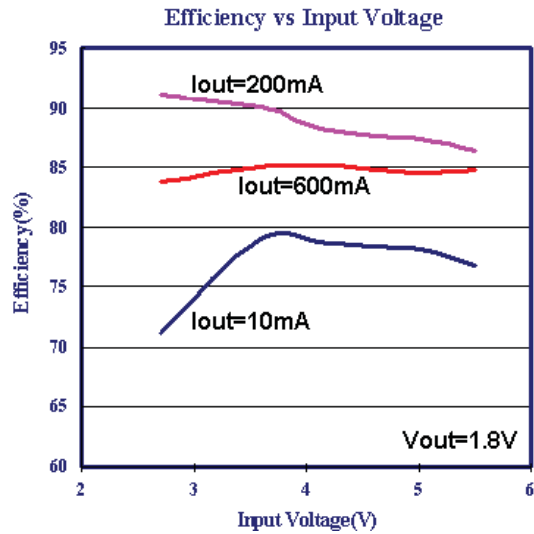
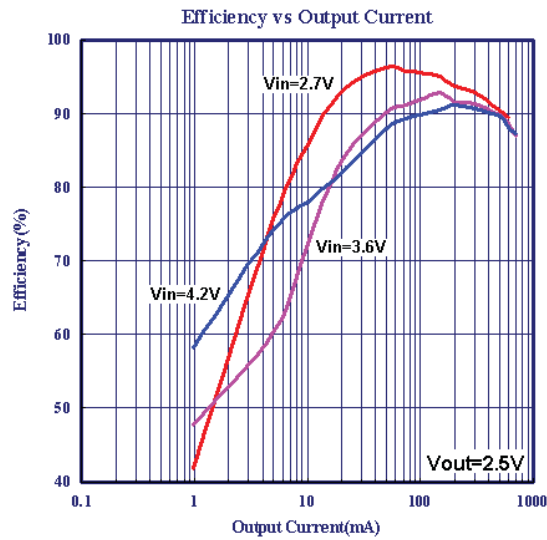
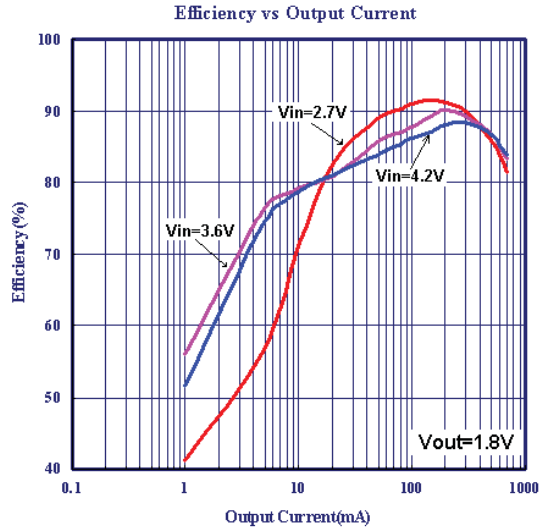
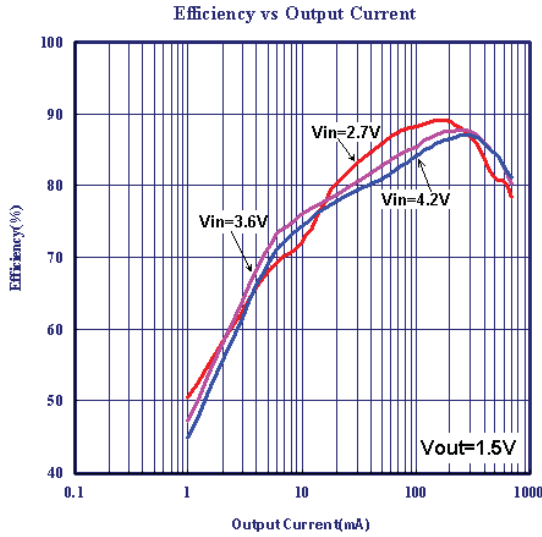

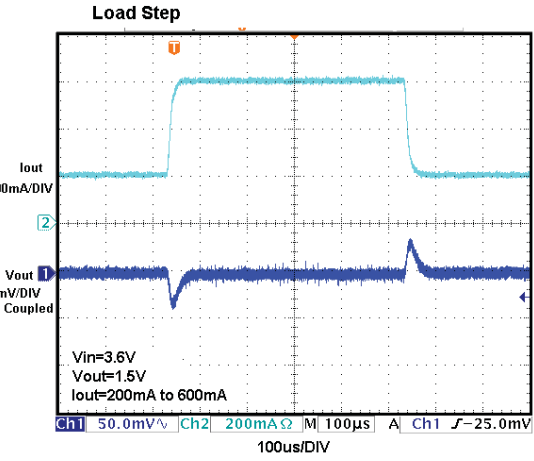
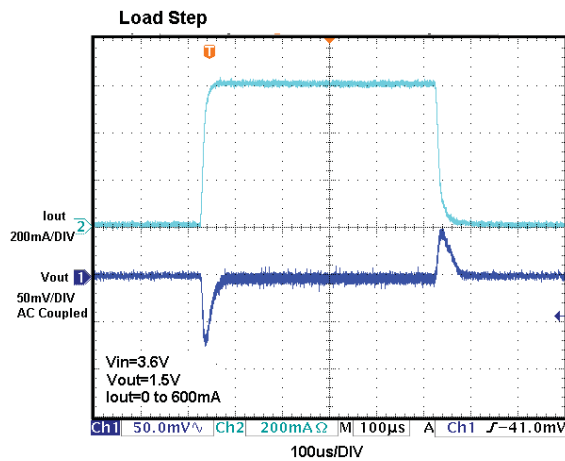
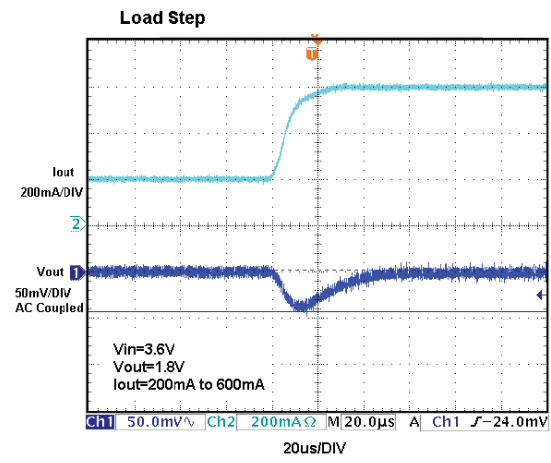
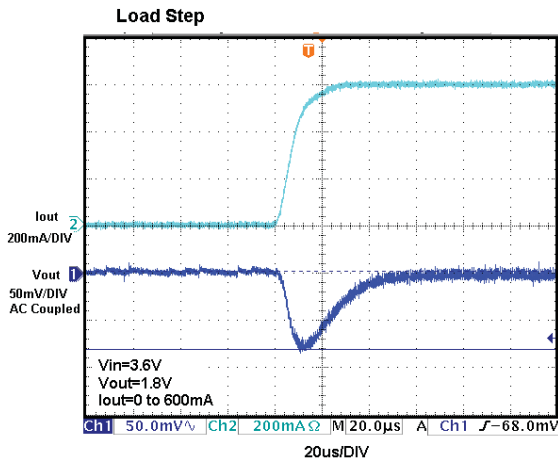
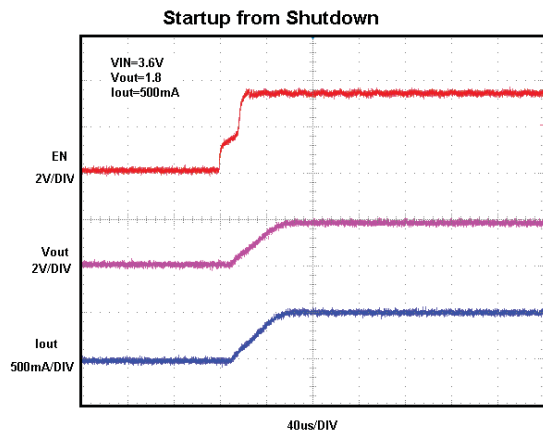
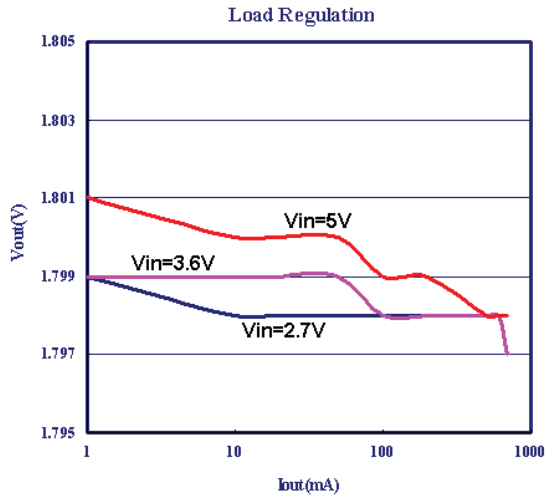

APPLICATION INFORMATION

Figure5 below shows the typical application circuit with FT4402 fixed output versions.

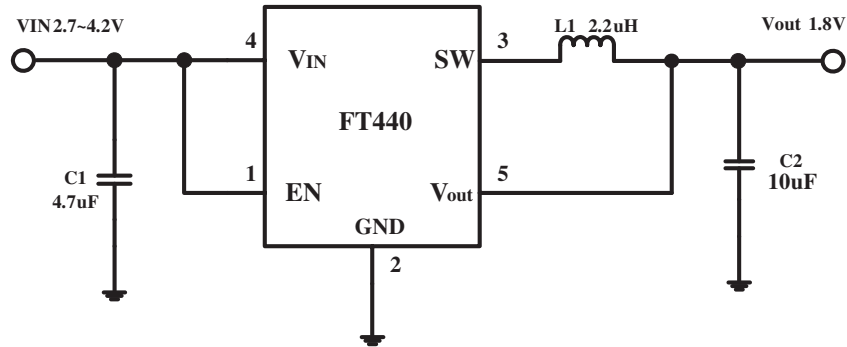

Figure 5: Typical Application Circuit with fixed output versions

Inductor Selection

Under normal operation, the inductor maintains continuous current to the output. Its value is chosen based on the desired ripple current. Large value inductors lower ripple current, and small value inductors result in higher ripple currents. The inductor value can be derived from the following equation:

$$L = \frac{V_{out} \times (V_{IN} - V_{out})}{V_{IN} \times \Delta I_L \times f_{osc}}, \text{ Where } \Delta I_L \text{ is inductor ripple current.}$$

Input Capacitor Selection

The input capacitor reduces input voltage ripple to the converter; a 4.7uF ceramic capacitor is recommended for most applications.

Output Capacitor Selection

The output capacitor is required to keep the output voltage ripple small and to ensure regulation loop stability. The output capacitor must have low impedance at the switching frequency. The output ripple ΔV_{out} approximately:

$$\Delta V_{OUT} \cong \Delta I_L \times \left(ESR + \frac{1}{8fC_{OUT}} \right)$$

Output Voltage Programming

Figure1 above shows the typical application with FT4402 adjustable version. The external resistor sets the output voltage according to following equation:

$$V_{OUT} = 0.6V \times \left(1 + \frac{R2}{R1} \right)$$

SOT23-5 PACKAGE

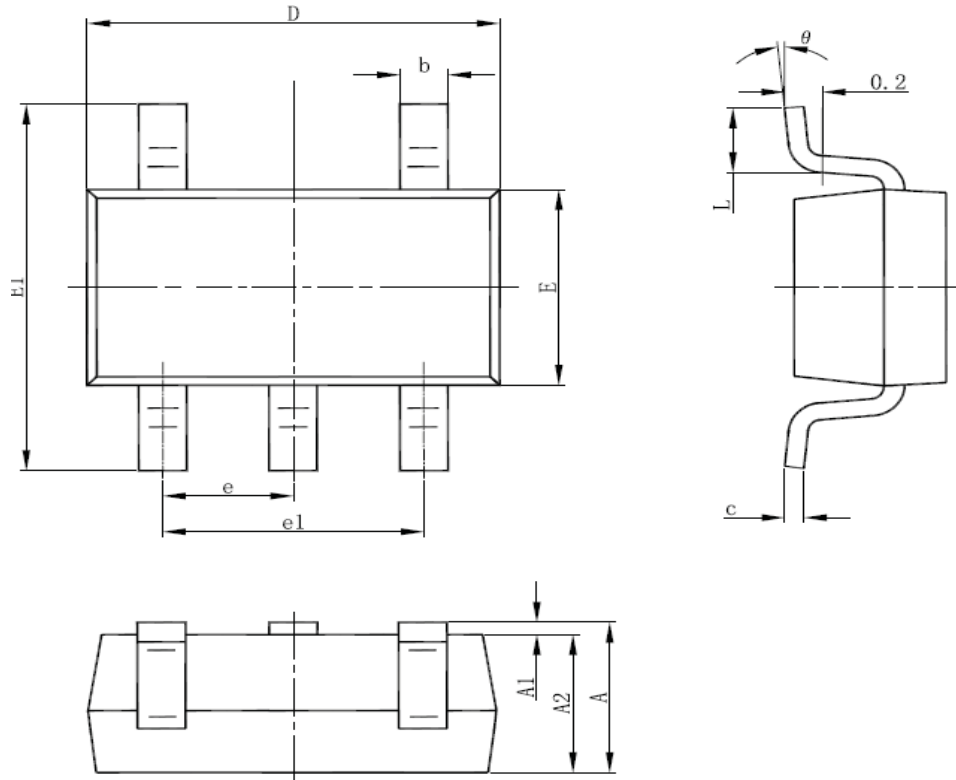

Symbol	Dimensions In Millimeters		Dimensions In Inches	
	Min	Max	Min	Max
A	1.050	1.250	0.041	0.049
A1	0.000	0.100	0.000	0.004
A2	1.050	1.150	0.041	0.045
b	0.300	0.500	0.012	0.020
c	0.100	0.200	0.004	0.008
D	2.820	3.020	0.111	0.119
E	1.500	1.700	0.059	0.067
E1	2.650	2.950	0.104	0.116
e	0.95 (BSC)		0.037 (BSC)	
e1	1.800	2.000	0.071	0.079
L	0.300	0.600	0.012	0.024
θ	0°	8°	0°	6°