

AMP P/N	A	B	C	D	E	F	REMARKS
846938-1	14.00±.12 [355.6±3.0]	.38 [9.7]	2.00 [50.8]	3.00 [76.2]	6.00 [152.4]	-	△3 OBSOLETE
846938-2	11.00±.12 [279.4±3.0]	.62 [15.7]	2.00 [50.8]	3.00 [76.2]	6.00 [152.4]	-	△3 OBSOLETE
846938-3	11.50±.12 [292.1±3.0]	.62 [15.7]	2.00 [50.8]	3.00 [76.2]	6.00 [152.4]	-	△3
846938-4	11.12±.12 [282.5±3.0]	.38 [9.7]	2.00 [50.8]	4.50 [114.3]	6.00 [152.4]	-	△3 OBSOLETE
846938-5	11.50±.12 [292.1±3.0]	.62 [15.7]	2.00 [50.8]	3.00 [76.2]	6.00 [152.4]	-	△3 OBSOLETE
846938-6	26.00±.26 [660.4±6.6]	.38 [9.7]	2.00 [50.8]	3.00 [76.2]	6.00 [152.4]	-	△3 OBSOLETE
846938-7	25.50±.25 [647.7±6.4]	.38 [9.7]	1.50 [38.1]	3.00 [76.2]	6.00 [152.4]	6.00 [152.4]	△3 OBSOLETE
846938-8	48.00±.48 [1219.2±6.4]	.38 [9.7]	2.00 [50.8]	3.00 [76.2]	6.00 [152.4]	-	△3
846938-9	11.50±.12 [292.1±3.0]	.62 [15.7]	.75 [19.1]	3.00 [76.2]	6.00 [152.4]	-	△3 OBSOLETE
1-846938-0	72.00±.72 [1828.8±18.3]	.38 [9.65]	2.00 [50.8]	3.00 [76.2]	6.00 [152.4]	6.00 [152.4]	△3 OBSOLETE
1-846938-1	192.00±1.92 [4876.8±48.8]	.38 [9.65]	2.00 [50.8]	3.00 [76.2]	6.00 [152.4]	6.00 [152.4]	△3 OBSOLETE
1-846938-2	288.00±2.88 [7315.2±73.2]	.38 [9.65]	2.00 [50.8]	3.00 [76.2]	6.00 [152.4]	6.00 [152.4]	△3 OBSOLETE
1-846938-3	10.00±.12 [254.0±3.0]	.38 [9.65]	2.00 [50.8]	3.00 [76.2]	6.00 [152.4]	6.00 [152.4]	△3
1-846938-4	51.00±.50 [1295.4±7.7]	.38 [9.65]	8.00 [203.2]	3.00 [76.2]	-	6.00 [152.4]	△3 OBSOLETE
1-846938-5	41.00±.41 [1041.4±10.4]	.38 [9.65]	13.00 [330.2]	3.00 [76.2]	-	6.00 [152.4]	△3 OBSOLETE
1-846938-6	36.00±.36 [914.4±9.1]	.38 [9.65]	13.00 [330.2]	3.00 [76.2]	-	6.00 [152.4]	△3
1-846938-7	50.00±.50 [1270.0±12.7]	.38 [9.65]	24.00 [609.6]	3.00 [76.2]	-	6.00 [152.4]	△3 OBSOLETE
1-846938-8	128.00±1.28 [3251.2±32.5]	.38 [9.65]	35.00 [889.0]	3.00 [76.2]	-	6.00 [152.4]	△3 OBSOLETE
1-846938-9	17.00±.12 [431.8±3.0]	.38 [9.65]	2.00 [50.8]	3.00 [76.2]	6.00 [152.4]	6.00 [152.4]	△3 OBSOLETE
2-846938-0	18.00±.12 [457.2±3.0]	.38 [9.65]	2.00 [50.8]	3.00 [76.2]	6.00 [152.4]	6.00 [152.4]	△3
2-846938-1	24.00±.12 [609.6±3.0]	.38 [9.65]	2.00 [50.8]	3.00 [76.2]	6.00 [152.4]	6.00 [152.4]	△3
2-846938-2	480.00±4.80 [12192±121.9]	.38 [9.65]	2.00 [50.8]	3.00 [76.2]	6.00 [152.4]	6.00 [152.4]	△3 OBSOLETE
2-846938-3	240.00±2.40 [6096.0±61.0]	.38 [9.65]	2.00 [50.8]	3.00 [76.2]	6.00 [152.4]	6.00 [152.4]	△3 OBSOLETE
2-846938-4	8.00±.12 [203.2±3.0]	.38 [9.65]	2.00 [50.8]	3.00 [76.2]	6.00 [152.4]	-	△3 OBSOLETE
2-846938-5	120.00±1.20 [3048.0±30.5]	.38 [9.65]	5.00 [127.0]	3.00 [76.2]	6.00 [152.4]	6.00 [152.4]	△3 OBSOLETE
2-846938-6	40.00±.40 [1016.0±10.2]	.38 [9.65]	2.00 [50.8]	3.00 [76.2]	6.00 [152.4]	-	△3 OBSOLETE
2-846938-7	80.00±.80 [2032±20.3]	.38 [9.65]	2.00 [50.8]	3.00 [76.2]	6.00 [152.4]	-	△3
2-846938-8	20.00±.12 [508.0±3.0]	.38 [9.65]	2.00 [50.8]	3.00 [76.2]	6.00 [152.4]	-	△3 OBSOLETE
2-846938-9	20.00±.12 [508.0±3.0]	.38 [9.65]	2.00 [50.8]	3.00 [76.2]	8.00 [203.2]	-	△3 OBSOLETE
3-846938-0	31.00±.31 [787.4±7.9]	.38 [9.65]	20.00 [508.0]	3.00 [76.2]	6.00 [152.4]	-	△3 OBSOLETE
3-846938-1	96.00±.96 [2438.4±24.4]	.38 [9.65]	3.00 [76.2]	3.00 [76.2]	6.00 [152.4]	6.00 [152.4]	△3 OBSOLETE
3-846938-2	96.00±.96 [2438.4±24.4]	.38 [9.65]	3.00 [76.2]	3.00 [76.2]	12.00 [304.8]	12.00 [304.8]	△3 OBSOLETE
3-846938-3	60.00±.60 [1524.0±15.3]	.38 [9.65]	3.00 [76.2]	3.00 [76.2]	6.00 [152.4]	6.00 [152.4]	△3 OBSOLETE
3-846938-4	29.00±.29 [736.6±7.4]	.38 [9.65]	3.00 [76.2]	3.00 [76.2]	6.00 [152.4]	6.00 [152.4]	△3 OBSOLETE
3-846938-5	29.00±.29 [736.6±7.4]	.38 [9.65]	20.00 [508.0]	3.00 [76.2]	6.00 [152.4]	6.00 [152.4]	△3
3-846938-6	48.00±.48 [1219.2±12.2]	.38 [9.65]	2.00 [50.8]	3.00 [76.2]	12.00 [304.8]	12.00 [304.8]	△3 OBSOLETE
3-846938-7	300.00±3.00 [7620.0±76.2]	.38 [9.65]	3.00 [76.2]	3.00 [76.2]	6.00 [152.4]	6.00 [152.4]	△3 OBSOLETE
3-846938-8	11.50±.12 [292.1±3.0]	.62 [15.7]	3.00 [76.2]	3.00 [76.2]	6.00 [152.4]	-	△3
3-846938-9	12.50±.12 [317.5±3.0]	.62 [15.7]	2.00 [50.8]	3.00 [76.2]	6.00 [152.4]	-	△3
6-846938-3	10.00±.12 [254.0±3.0]	.38 [9.65]	2.00 [50.8]	3.00 [76.2]	6.00 [152.4]	6.00 [152.4]	△4
8-846938-5	29.00±.29 [736.6±7.4]	.38 [9.65]	20.00 [508.0]	3.00 [76.2]	6.00 [152.4]	6.00 [152.4]	△4

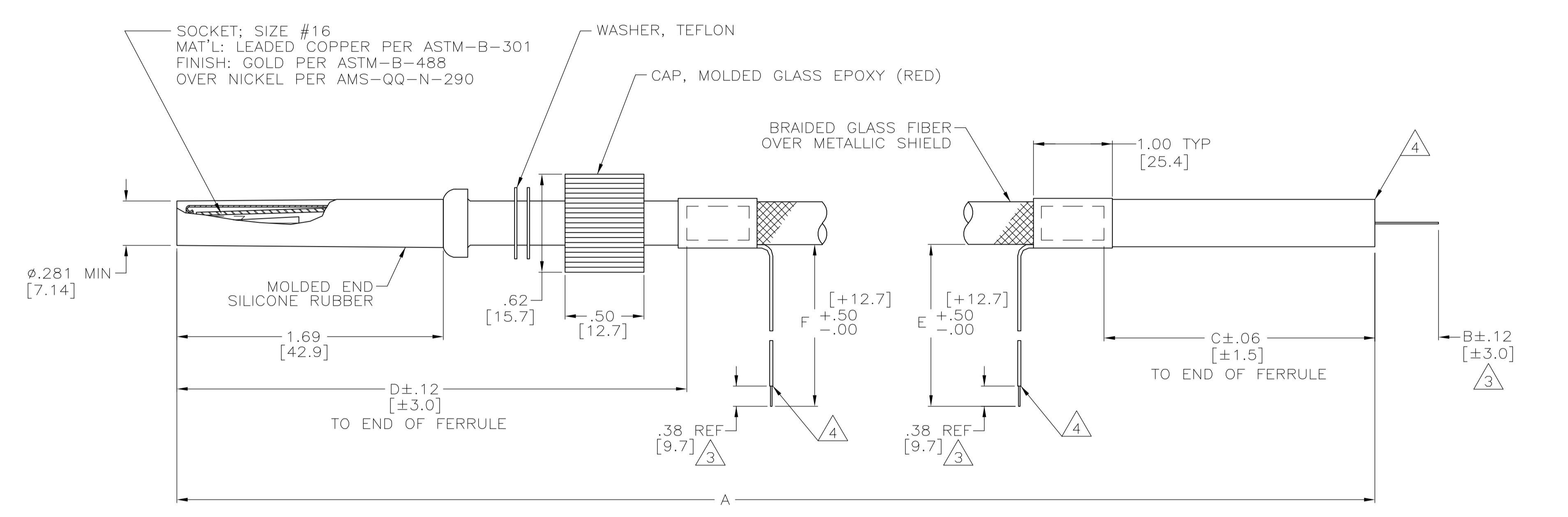

LOC	DIST	REV	DESCRIPTION	DATE	BY	APPV
DF	SO	AC	REV PER ECO-05-002357	08-05	AA	DE

- MARKED PER MIL-STD-130.
  - TO MATE WITH AMP LGH-1L RECEPTACLE WITH 1.69 BARREL DEPTH.
- △3 PIGTAILS ARE SOLDER DIPPED.  
△4 INSULATION CUT, BUT NOT REMOVED.

THIS DRAWING IS A CONTROLLED DOCUMENT.

DIMENSIONS: INCHES (mm)	TOLERANCES UNLESS OTHERWISE SPECIFIED: 0 PLC ± - 1 PLC ± - 2 PLC ± .02 (0.5) 3 PLC ± .005 (0.13) 4 PLC ± - ANGLES ± -	DWG T. THOMPSON 28-APR-93	DATE 28-MAY-93		Tyco Electronics Corporation Harrisburg, Pa 17105-3608
MATERIAL SEE CALLOUTS	FINISH SEE CALLOUTS	APVD S. GLATFELTER 28-MAY-93	NAME S. GLATFELTER		PRODUCT SPEC
CUSTOMER DRAWING		SIZE A1	CAGE CODE 00779	DRAWING NO. 846938	SCALE 2:1

LEAD ASSY, ELECTRICAL  
MOLDED END WITH SHIELD & GLASS BRAID JACKET  
LGH-1L

SHEET 1 OF 1