

THIS DRAWING IS UNPUBLISHED. RELEASED FOR PUBLICATION
 © COPYRIGHT BY TYCO ELECTRONICS CORPORATION. ALL RIGHTS RESERVED.

LOC	DIST	REVISIONS			
P	LTR	DESCRIPTION	DATE	DWN	APVD
AF	50	J1	REDRAWN PER ECR-07-029463	6DEC07	MF DD

- 1 CONTINUOUS STRIP ON REELS.
- 2 WIRE RANGE: 0.8-2.0mm² [#18-#14] AWG.

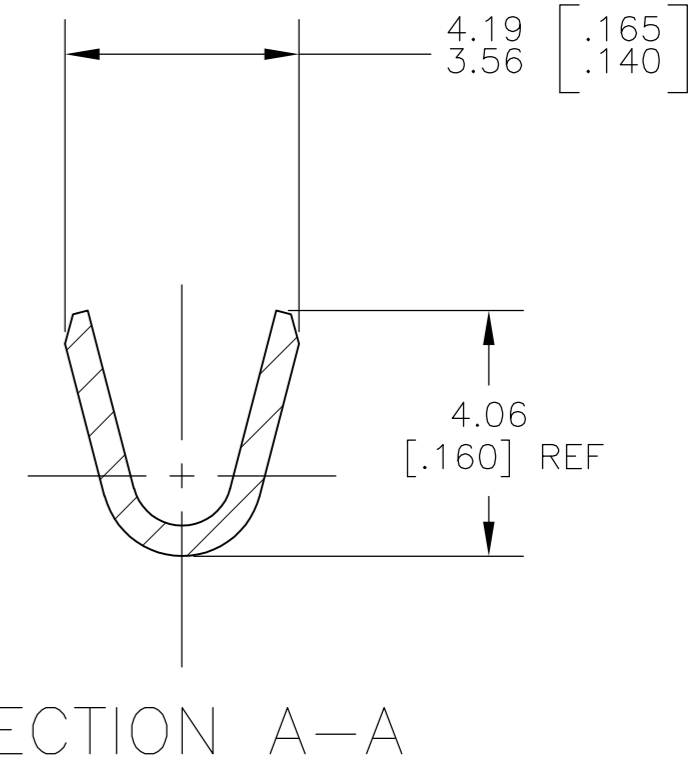
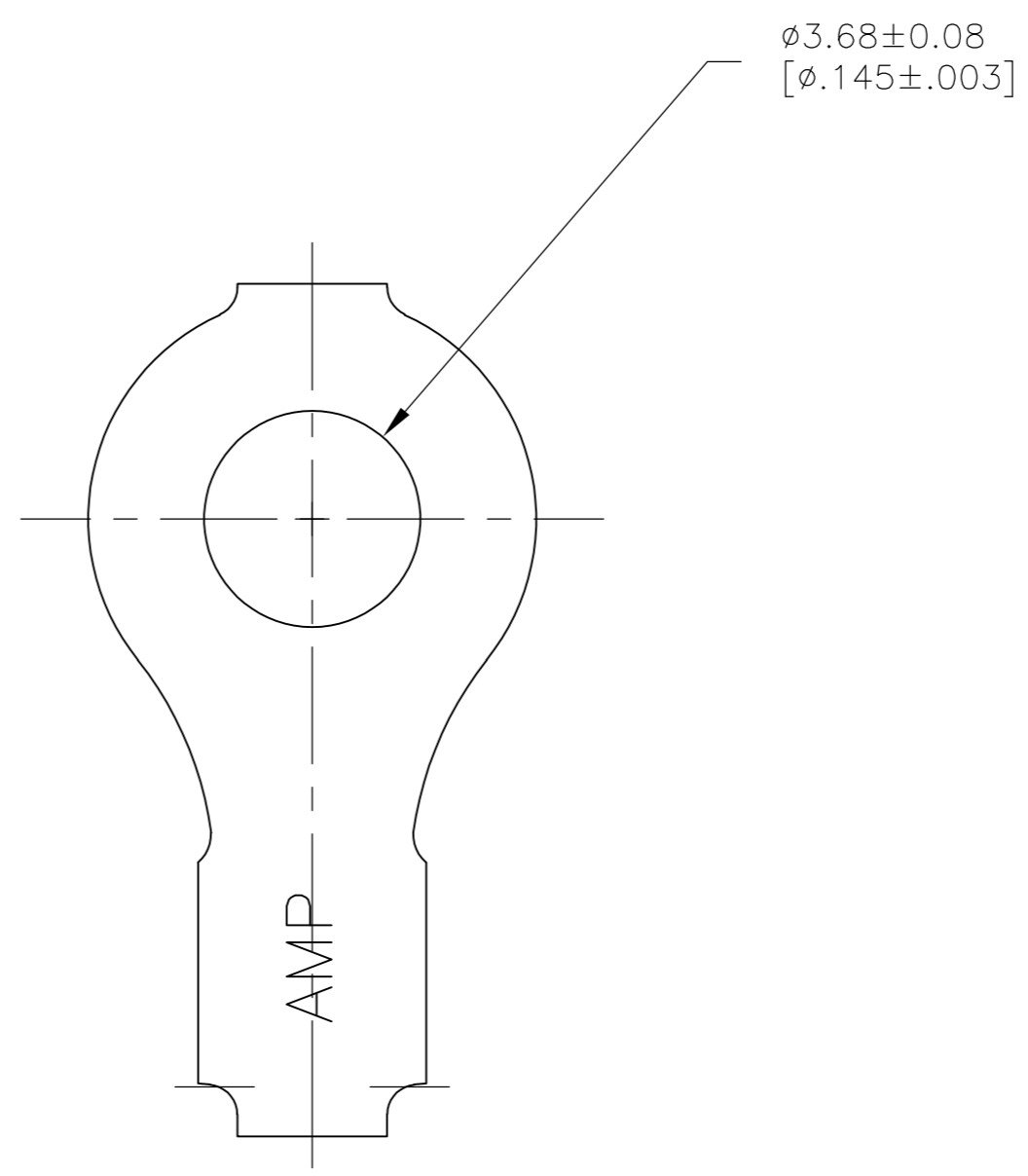
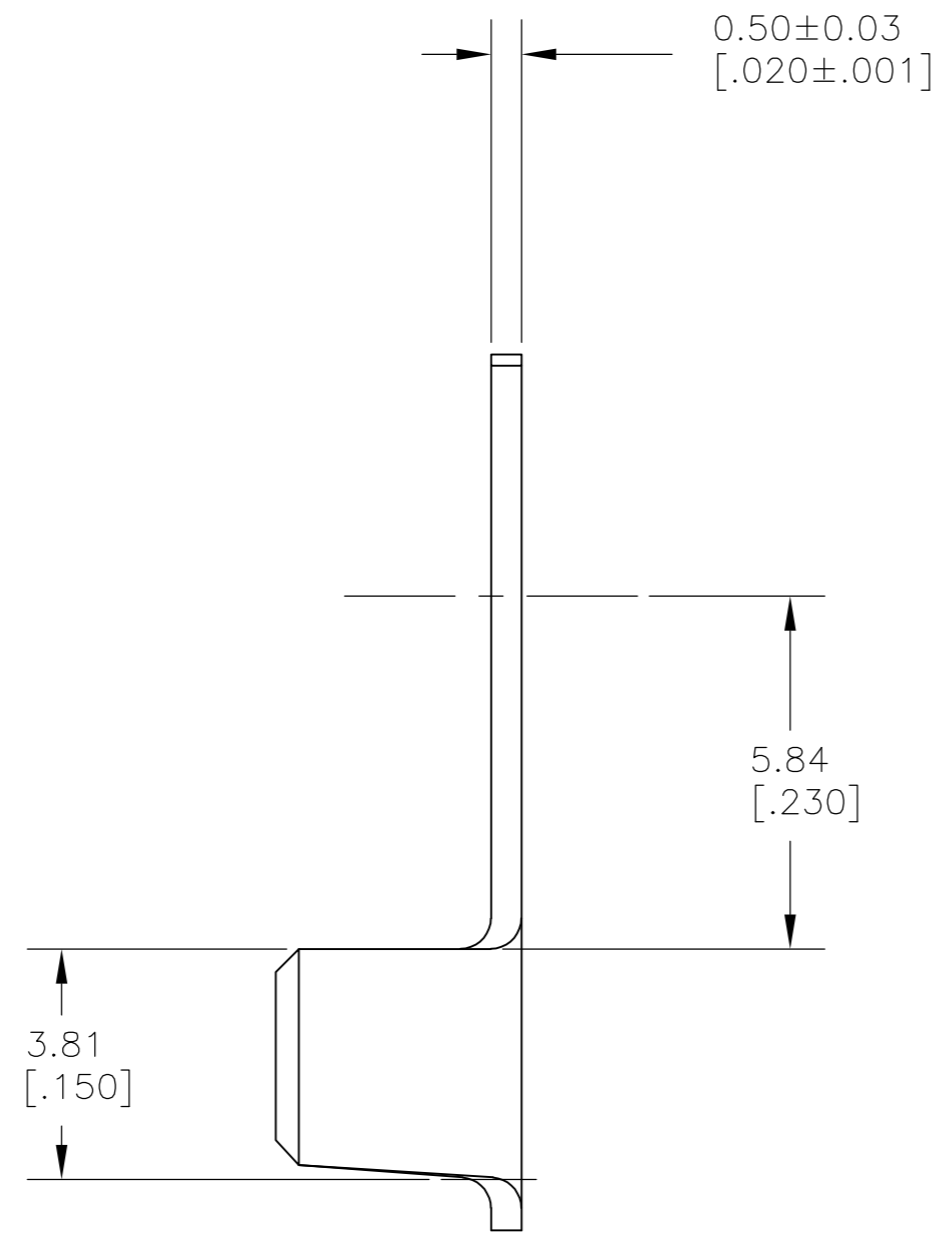
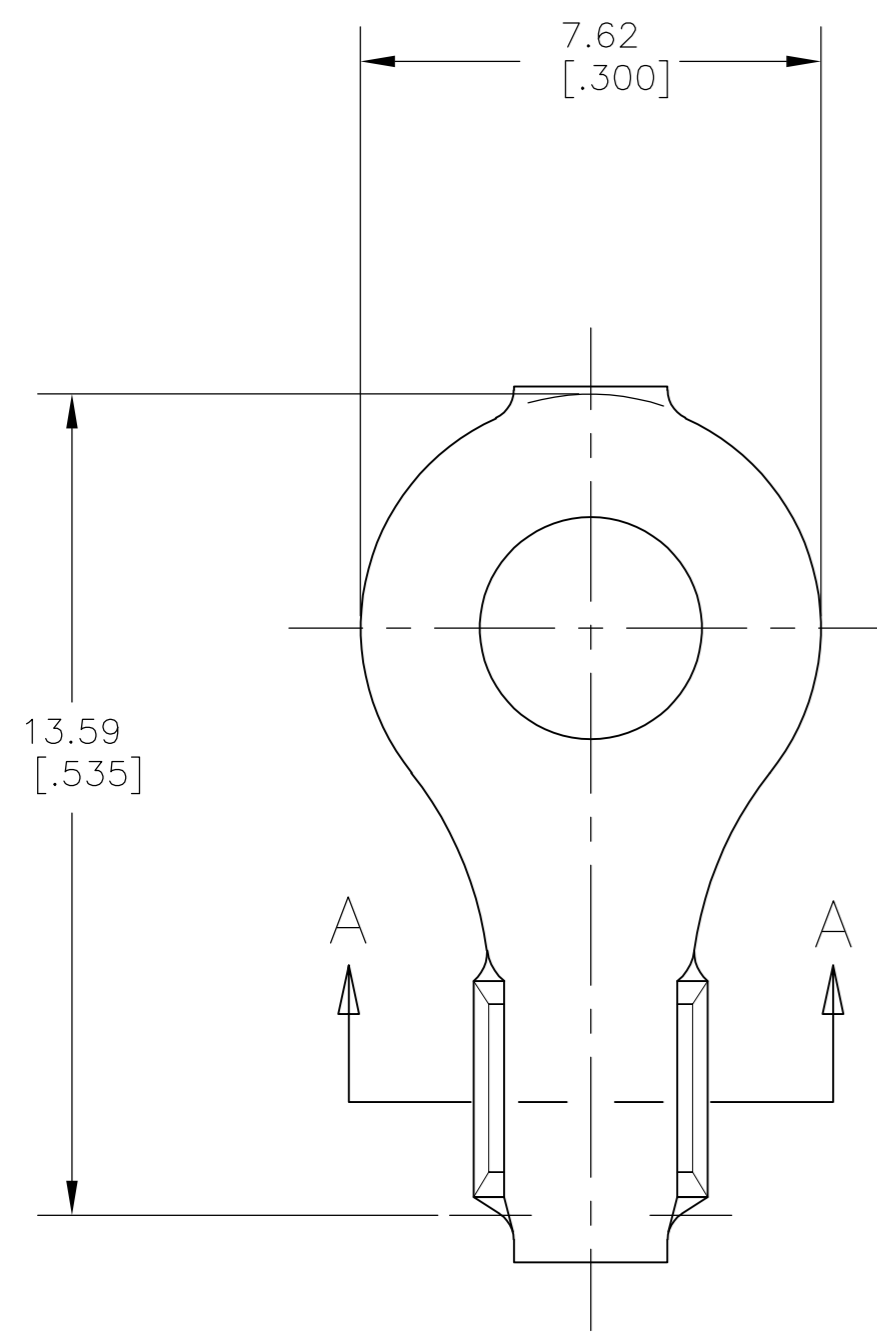

34848
 PART NUMBER

THIS DRAWING IS A CONTROLLED DOCUMENT.		DWN 23OCT2007 MICHAEL S. FEHER	Tyco Electronics Corporation Harrisburg, PA 17105-3608
DIMENSIONS: mm [INCHES]		CHK 23OCT2007 DONALD F. DECKER	
TOLERANCES UNLESS OTHERWISE SPECIFIED:		APVD 23OCT2007 DONALD F. DECKER	NAME
0 PLC ± - 1 PLC ± - 2 PLC ± - 3 PLC ± 0.38 [.015] 4 PLC ± - ANGLES ± 1°		PRODUCT SPEC	TERMINAL, RING NUMBER 6 STUD SIZE M3.5 METRIC
MATERIAL 082 BRASS		FINISH -	SIZE A2
		WEIGHT -	CAGE CODE 00779
		CUSTOMER DRAWING	DRAWING NO C=34848
		SCALE 8:1	RESTRICTED TO -
		SHEET 1 of 1	REV J1