

PAGE 1/3	ISSUE 11-12-17A	SERIES SMP-MAX	PART NUMBER R222M46012
----------	-----------------	-----------------------	-------------------------------

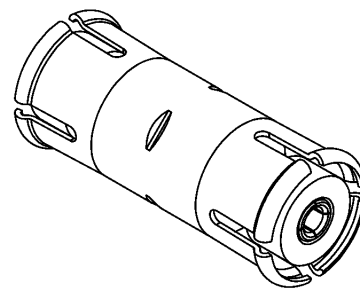

All dimensions are in mm. Tolerances according ISO 2768 m-H

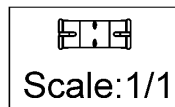
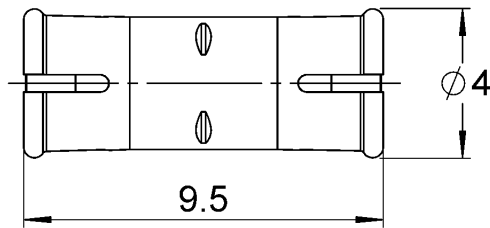
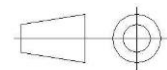

COMPONENTS	MATERIALS	PLATING (μm)
Body	-	-
Center contact	BERYLLIUM COPPER	NPGR
Outer contact	BERYLLIUM COPPER	NPGR
Insulator	PTFE	
Gasket	-	-
Others parts	-	-
-	-	-
-	-	-

PAGE 2/3	ISSUE 11-12-17A	SERIES SMP-MAX	PART NUMBER R222M46012
----------	-----------------	-----------------------	-------------------------------

PACKAGING

Standard	Unit	Other
100	Contact us	Contact us

ELECTRICAL CHARACTERISTICS

Impedance **50** Ω
 Frequency **0 - 10** GHz
 VSWR (max.) / Return Loss (max.)

DC - 2 GHz	2 - 4 GHz	4 - 6 GHz
1.07 / -30dB	1.12 / -27dB	1.14 / -24dB

Insertion loss **< 0.05*** √F(GHz) dB
 RF leakage - (**NA** - F(GHz)) dB
 Voltage rating **335** Veff Maxi
 Dielectric withstanding voltage **1000** Veff mini
 Insulation resistance **5000** MΩ mini

MECHANICAL CHARACTERISTICS

Center contact retention
 Axial force – Mating End **7** N mini
 Axial force – Opposite end **7** N mini
 Torque **NA** N.cm mini

Radial working range **0.0000** mm
 Warning: To ensure a blind mate assembly, please check the pull-in range of the mating receptacle.

Recommended torque
 Mating **NA** N.cm
 Panel nut **NA** N.cm

Mating life **100** Cycles mini
 Weight **0.2280** g

ENVIRONMENTAL

Operating temperature **-55/+165** °C
 Hermetic seal **NA** Atm.cm3/s
 Panel leakage **NA**

SPECIFICATION

OTHER CHARACTERISTICS

Assembly instruction: **NA**

Others:
 *Coaxial Transmission Line Only
 Radial working angle: 3°min.
 Axial working range: 2.0mm or 2.4mm (should be with special receptacle for axial misalignment ±1.2).

PAGE 3/3	ISSUE 11-12-17A	SERIES SMP-MAX	PART NUMBER R222M46012
----------	-----------------	-----------------------	-------------------------------

GENERAL DATA OF SMP-MAX SERIE

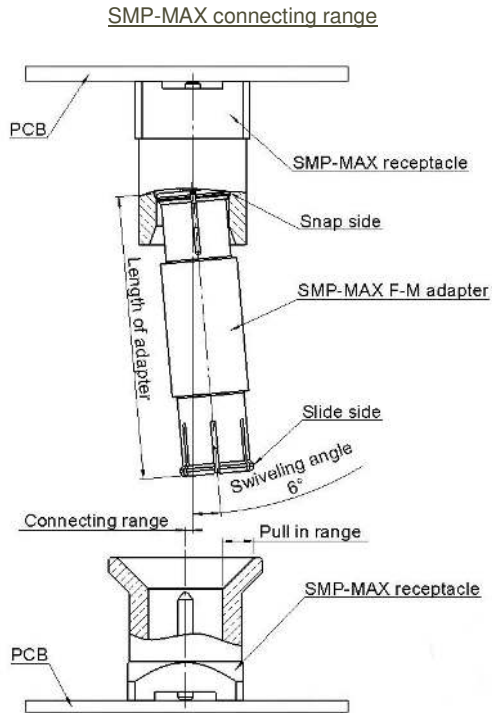

SMP-MAX radial and axial working range

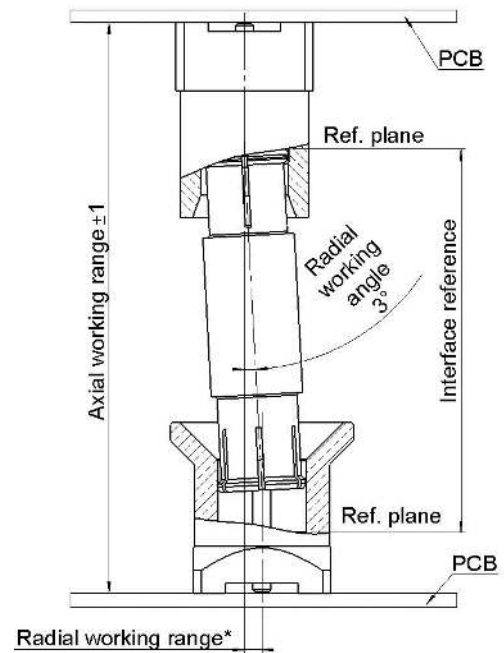

The connecting range represents the maximum misalignment during connection.

The swiveling angle is the maximum possible angle of the adapter in a snap receptacle.

A blind assembly is guaranteed if radial misalignment is smaller than connecting range. Otherwise a manual lead-in is necessary.

Electrical performance is achieved when radial and axial misalignments are within their working ranges.

Radial working range = (length of the adapter) x Sinus(radial working angle)

Typical RF performances for a set:

slide receptacle + adapter + snap receptacle (receptacles soldered on boards):

V.S.W.R / Return loss	Misalignment	DC - 3 GHz	3 - 6 GHz
	Radial 0°, Axial 0mm	<1.15/-23.9 dB	<1.25/-19.10 dB
	Radial 0°, Axial +/-1mm	<1.20/-20.8 dB	<1.35/-16.5 dB
	Radial 3°, Axial 0mm	<1.15/-23.1 dB	<1.25/-19.1 dB
	Radial 3°, Axial +/-1mm	<1.20/-20.8 dB	<1.35/-16.5 dB
Insertion loss	Misalignment	DC - 3 GHz	3 - 6 GHz
	Radial 0°, Axial 0mm	<0.10 dB	<0.15 dB
	Radial 0°, Axial +/-1mm	<0.12 dB	<0.25 dB
	Radial 3°, Axial 0mm	<0.10 dB	<0.15 dB
	Radial 3°, Axial +/-1mm	<0.12 dB	<0.25 dB
handling power	>300W@2.7GHz at 25°C; >200W@2.7GHz at 85°C		