

Spezifikation für Freigabe / specification for release

Kunde / customer :

Artikelnummer / part number :

7498210002



Bezeichnung : **LAN-Übertrager WE-RJ45LAN 10/100BaseT**

description : **LAN-Transformer WE-RJ45LAN 10/100BaseT PoE+**

DATUM / DATE : 2014-06-24

A Mechanische Abmessungen / dimensions :

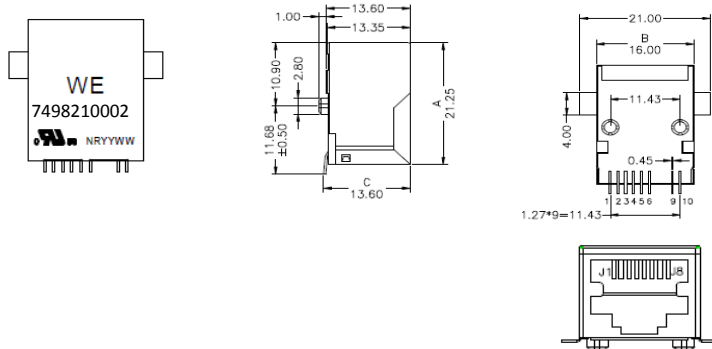

B Lötbad / soldering spec. :

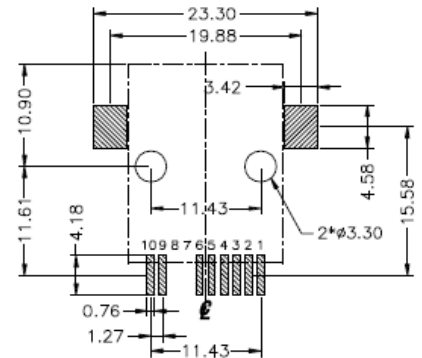

C Elektrische Eigenschaften / electrical properties :

Eigenschaften / properties	Testbedingungen / test conditions		Wert / value	Einheit / unit	tol.
Induktivität / Inductance	100kHz / 100mV @ 8mA DC-Bias	OCL	350	µH	min.
Übersetzungsverhältnis / Turns ratio	100kHz / 100mV	TR	1 : 1	Tx	
			1 : 1	Rx	
Insertion Loss	1-100MHz	IL	-1,1	dB	max.
Return Loss	0.5-30MHz @ 100Ω	RL	-18	dB	min.
	30-60MHz @ 100Ω		-14		
	60-80MHz @ 100Ω		-12		
Common Mode Rejection	1-130MHz	CMR	-30	dB	min.
Crosstalk	0.5-40MHz	CT	-35	dB	min.
	40-100MHz		-30		

D Prüfgeräte / test equipment :

HP4395A

E Testbedingungen / test conditions :

Luftfeuchtigkeit / humidity: 33%
Umgebungstemperatur / temperature: +25°C

F Werkstoffe & Zulassungen / material & approvals :

Basismaterial / base material: Ferrit/ ferrite
 Draht / wire: UEW/Y 180°C
 Kontaktmaterial/ contact plating: 100% tin w. nickel underplating
 30µ"gold plating on contact area
 Gehäuse / housing: Thermoplastic UL-94V0
 LED: n/a
 Shield: 50µ" nickel over 0.01" cooper alloy

G Eigenschaften / general specifications :

Betriebstemp. / operating temperature: -40°C - +85°C
 Hochspannungsprüfung / Hipot test: 2250Vdc 1min.
 Geeignet für 10/100Base-TX gemäß IEEE 802.3at /
 Compliant with IEEE 802.3at for 10/100Base-TX-Applications
 Auto MDIX fähig / Auto MDIX capable

Freigabe erteilt / general release:

Kunde / customer

Datum / date

Unterschrift / signature

Würth Elektronik

Geprüft / checked

Kontrolliert / approved

Mle	Revision 01	2014-06-24
LuRa	Revision 00	2014-06-04
Name	Änderung / modification	Datum / date

Würth Elektronik eiSos GmbH & Co.KG

D-74638 Waldenburg · Max-Eyth-Straße 1 - 3 · Germany · Telefon (+49) (0) 7942 - 945 - 0 · Telefax (+49) (0) 7942 - 945 - 400
<http://www.we-online.com>

Spezifikation für Freigabe / specification for release

Kunde / customer : **Preliminary**
 Artikelnummer / part number : **7498210002**
 Bezeichnung : **LAN-Übertrager WE-RJ45LAN 10/100BaseT**
 description : **LAN-Transformer WE-RJ45LAN 10/100BaseT PoE+**



DATUM / DATE : 2014-06-24

H Schaltbild / Schematics :

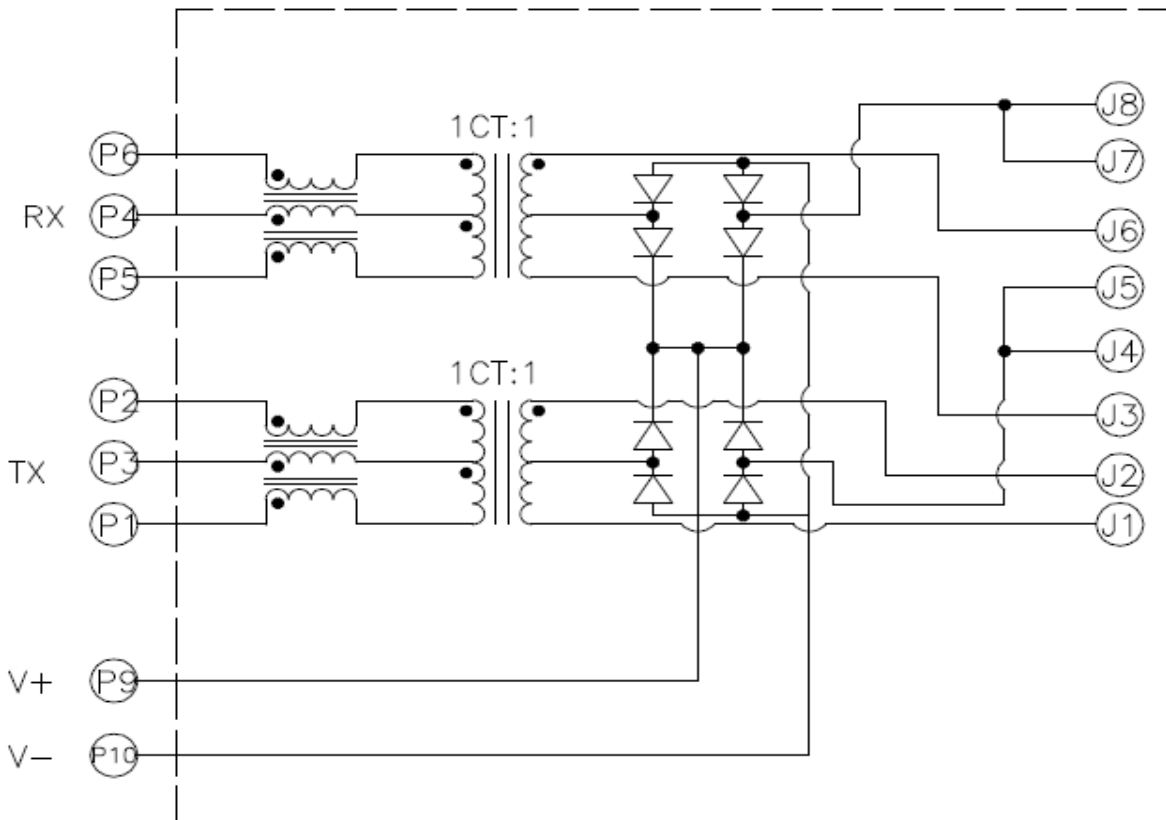

Freigabe erteilt / general release:	Kunde / customer			
.....			
Datum / date	Unterschrift / signature			
	Würth Elektronik			
.....	Mle	Revision 01	2014-06-24
Geprüft / checked	Kontrolliert / approved	LuRa	Revision 00	2014-06-04
		Name	Änderung / modification	Datum / date

Würth Elektronik eiSos GmbH & Co.KG

D-74638 Waldenburg · Max-Eyth-Straße 1 - 3 · Germany · Telefon (+49) (0) 7942 - 945 - 0 · Telefax (+49) (0) 7942 - 945 - 400
<http://www.we-online.com>

Spezifikation für Freigabe / specification for release

Kunde / customer : **Preliminary**
 Artikelnummer / part number : **7498210002**
 Bezeichnung : **LAN-Übertrager WE-RJ45LAN 10/100BaseT**
 description : **LAN-Transformer WE-RJ45LAN 10/100BaseT PoE+**



DATUM / DATE : 2014-06-24

I Verpackungsspezifikation / package specification :



(13" Reel)

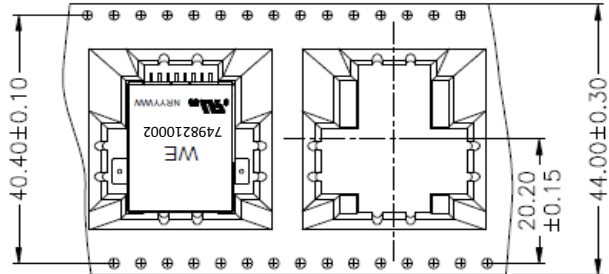

100 Pcs / Reel

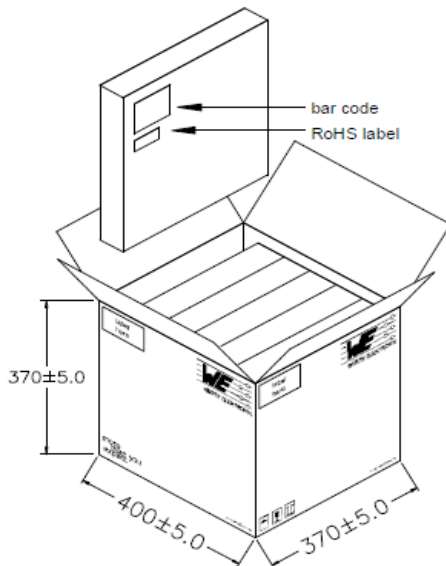

PACKING QUANTITY:

100pcs Finished Goods / Reel

6 Reel (600pcs Finished Goods) / Carton

Freigabe erteilt / general release:

Kunde / customer

Datum / date

Unterschrift / signature

Würth Elektronik

Geprüft / checked

Kontrolliert / approved

Mie	Revision 01	2014-06-24
LuRa	Revision 00	2014-06-04
Name	Änderung / modification	Datum / date

This electronic component has been designed and developed for usage in general electronic equipment. Before incorporating this component into any equipment where higher safety and reliability is especially required or if there is the possibility of direct damage or injury to human body, for example in the range of aerospace, aviation, nuclear control, submarine, transportation, (automotive control, train control, ship control), transportation signal, disaster prevention, medical, public information network etc, Würth Elektronik eiSos GmbH must be informed before the design-in stage. In addition, sufficient reliability evaluation checks for safety must be performed on every electronic component which is used in electrical circuits that require high safety and reliability functions or performance.

Würth Elektronik eiSos GmbH & Co.KG

D-74638 Waldenburg · Max-Eyth-Straße 1 · 3 · Germany · Telefon (+49) (0) 7942 - 945 - 0 · Telefax (+49) (0) 7942 - 945 - 400
<http://www.we-online.com>