

Phase Control IC

TCA 785

Bipolar IC

Features

- Reliable recognition of zero passage
- Large application scope
- May be used as zero point switch
- LSL compatible
- Three-phase operation possible (3 ICs)
- Output current 250 mA
- Large ramp current range
- Wide temperature range

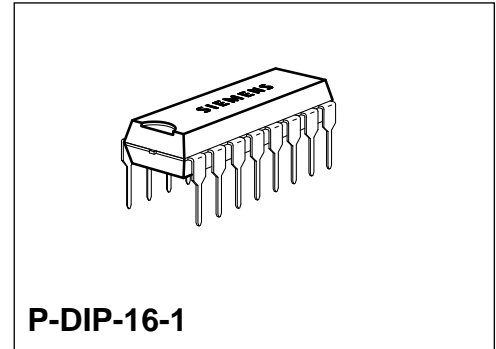

Type	Ordering Code	Package
TCA 785	Q67000-A2321	P-DIP-16-1

This phase control IC is intended to control thyristors, triacs, and transistors. The trigger pulses can be shifted within a phase angle between 0 ° and 180 °. Typical applications include converter circuits, AC controllers and three-phase current controllers.

This IC replaces the previous types TCA 780 and TCA 780 D.

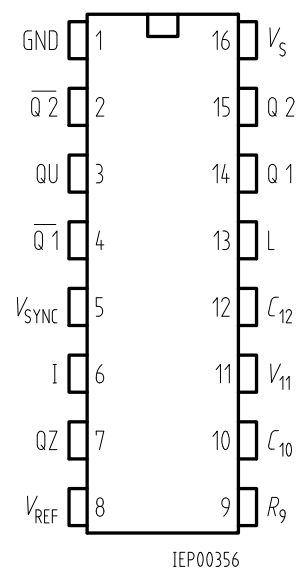

Pin Configuration (top view)

Pin Definitions and Functions

Pin	Symbol	Function
1	GND	Ground
2	$\overline{Q2}$	Output 2 inverted
3	\overline{QU}	Output U
4	$\overline{Q2}$	Output 1 inverted
5	V_{SYNC}	Synchronous voltage
6	I	Inhibit
7	QZ	Output Z
8	V_{REF}	Stabilized voltage
9	R_9	Ramp resistance
10	C_{10}	Ramp capacitance
11	V_{11}	Control voltage
12	C_{12}	Pulse extension
13	L	Long pulse
14	Q 1	Output 1
15	Q 2	Output 2
16	V_S	Supply voltage

Functional Description

The synchronization signal is obtained via a high-ohmic resistance from the line voltage (voltage V_s). A zero voltage detector evaluates the zero passages and transfers them to the synchronization register.

This synchronization register controls a ramp generator, the capacitor C_{10} of which is charged by a constant current (determined by R_9). If the ramp voltage V_{10} exceeds the control voltage V_{11} (triggering angle φ), a signal is processed to the logic. Dependent on the magnitude of the control voltage V_{11} , the triggering angle φ can be shifted within a phase angle of 0° to 180° .

For every half wave, a positive pulse of approx. $30 \mu s$ duration appears at the outputs Q 1 and Q 2. The pulse duration can be prolonged up to 180° via a capacitor C_{12} . If pin 12 is connected to ground, pulses with a duration between φ and 180° will result.

Outputs $\overline{Q1}$ and $\overline{Q2}$ supply the inverse signals of Q 1 and Q 2.

A signal of $\varphi + 180^\circ$ which can be used for controlling an external logic, is available at pin 3.

A signal which corresponds to the NOR link of Q 1 and Q 2 is available at output Q Z (pin 7).

The inhibit input can be used to disable outputs Q1, Q2 and $\overline{Q1}$, $\overline{Q2}$.

Pin 13 can be used to extend the outputs $\overline{Q1}$ and $\overline{Q2}$ to full pulse length ($180^\circ - \varphi$).

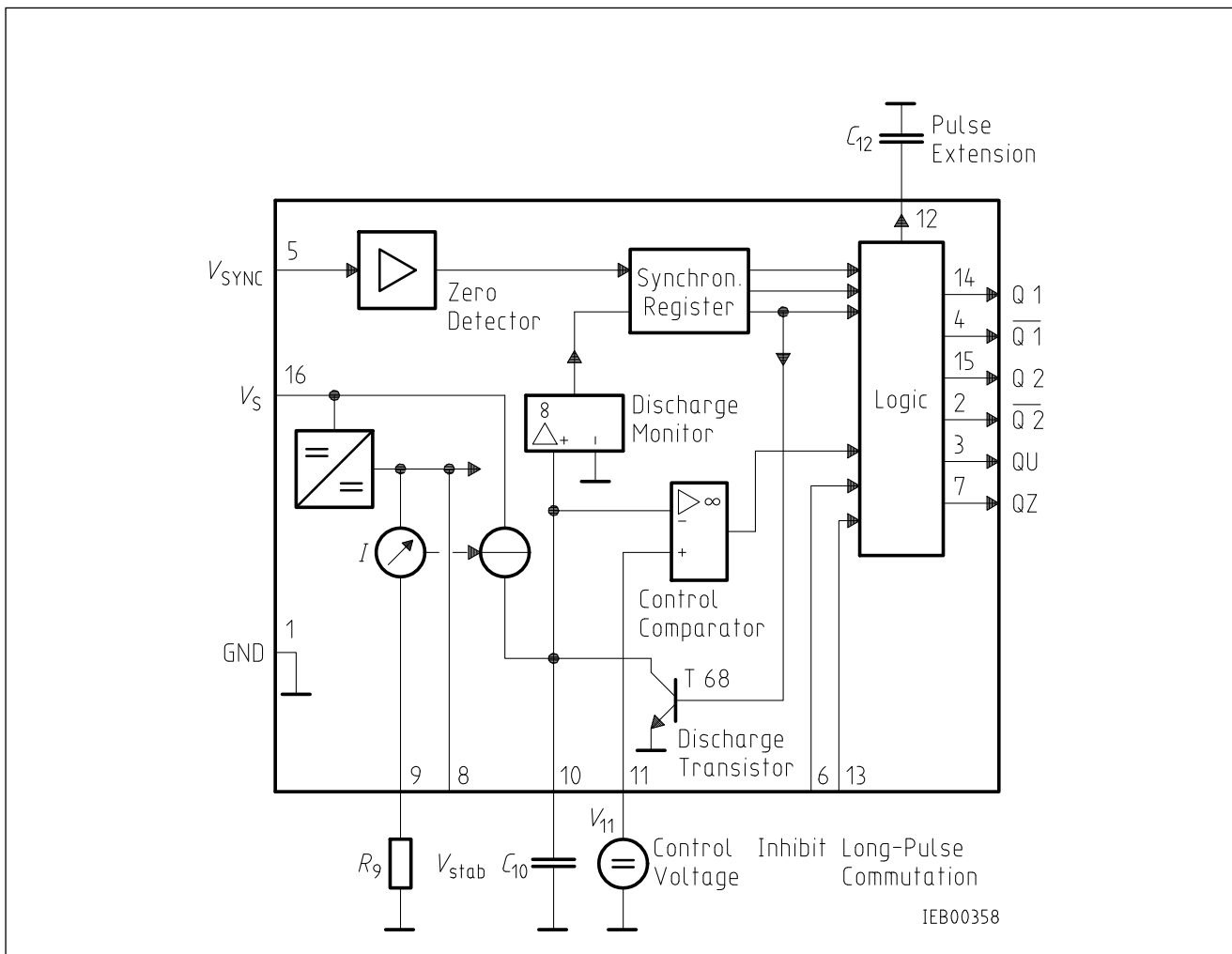

Block Diagram

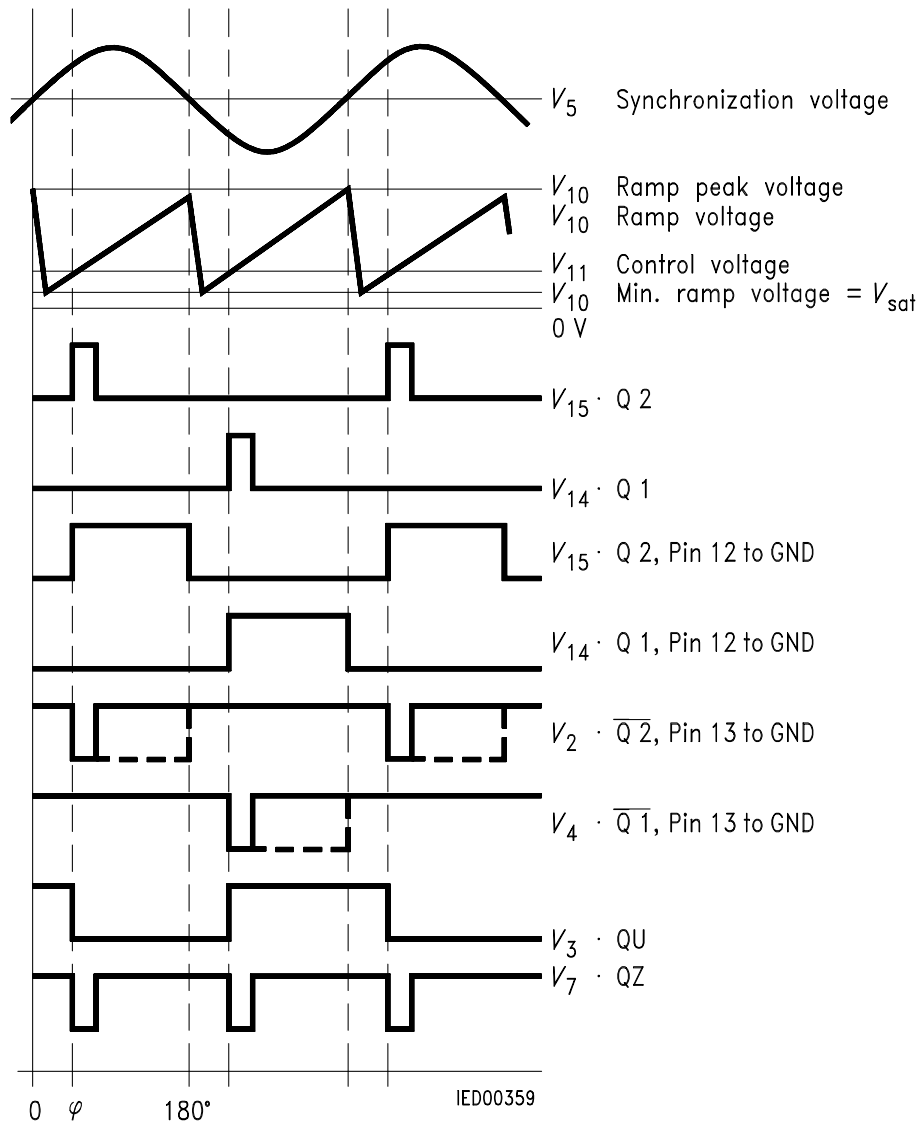

Pulse Diagram

Absolute Maximum Ratings

Parameter	Symbol	Limit Values		Unit
		min.	max.	
Supply voltage	V_S	- 0.5	18	V
Output current at pin 14, 15	I_Q	- 10	400	mA
Inhibit voltage	V_6	- 0.5	V_S	V
Control voltage	V_{11}	- 0.5	V_S	V
Voltage short-pulse circuit	V_{13}	- 0.5	V_S	V
Synchronization input current	V_5	- 200	± 200	μA
Output voltage at pin 14, 15	V_Q		V_S	V
Output current at pin 2, 3, 4, 7	I_Q		10	mA
Output voltage at pin 2, 3, 4, 7	V_Q		V_S	V
Junction temperature	T_j		150	$^{\circ}C$
Storage temperature	T_{stg}	- 55	125	$^{\circ}C$
Thermal resistance system - air	$R_{th SA}$		80	K/W

Operating Range

Supply voltage	V_S	8	18	V
Operating frequency	f	10	500	Hz
Ambient temperature	T_A	- 25	85	$^{\circ}C$

Characteristics

$8 \leq V_S \leq 18 \text{ V}; -25 \text{ }^{\circ}C \leq T_A \leq 85 \text{ }^{\circ}C; f = 50 \text{ Hz}$

Parameter	Symbol	Limit Values			Unit	Test Circuit
		min.	typ.	max.		
Supply current consumption S1 ... S6 open $V_{11} = 0 \text{ V}$ $C_{10} = 47 \text{ nF}; R_9 = 100 \text{ k}\Omega$	I_S	4.5	6.5	10	mA	1
Synchronization pin 5 Input current R_2 varied	$I_{5 rms}$	30		200	μA	1
Offset voltage	ΔV_5		30	75	mV	4
Control input pin 11 Control voltage range	V_{11}	0.2		$V_{10 peak}$	V	1
Input resistance	R_{11}		15		$k\Omega$	5

Characteristics (cont'd)

$8 \leq V_S \leq 18 \text{ V}$; $-25 \text{ }^\circ\text{C} \leq T_A \leq 85 \text{ }^\circ\text{C}$; $f = 50 \text{ Hz}$

Parameter	Symbol	Limit Values			Unit	Test Circuit
		min.	typ.	max.		
Ramp generator Charge current	I_{10}	10		1000	μA	
Max. ramp voltage	V_{10}			$V_2 - 2$	V	1
Saturation voltage at capacitor	V_{10}	100	225	350	mV	1.6
Ramp resistance	R_9	3		300	$\text{k}\Omega$	1
Sawtooth return time	t_f		80		μs	1
Inhibit pin 6 switch-over of pin 7						
Outputs disabled	V_{6L}		3.3	2.5	V	1
Outputs enabled	V_{6H}	4	3.3		V	1
Signal transition time	t_r	1		5	μs	1
Input current $V_6 = 8 \text{ V}$	I_{6H}		500	800	μA	1
Input current $V_6 = 1.7 \text{ V}$	$-I_{6L}$	80	150	200	μA	1
Deviation of I_{10} $R_9 = \text{const.}$ $V_S = 12 \text{ V}$; $C_{10} = 47 \text{ nF}$	I_{10}	-5		5	%	1
Deviation of I_{10} $R_9 = \text{const.}$ $V_S = 8 \text{ V to } 18 \text{ V}$	I_{10}	-20		20	%	1
Deviation of the ramp voltage between 2 following half-waves, $V_S = \text{const.}$	$\Delta V_{10 \text{ max}}$		± 1		%	
Long pulse switch-over pin 13 switch-over of S8						
Short pulse at output	V_{13H}	3.5	2.5		V	1
Long pulse at output	V_{13L}		2.5	2	V	1
Input current $V_{13} = 8 \text{ V}$	I_{13H}			10	μA	1
Input current $V_{13} = 1.7 \text{ V}$	$-I_{13L}$	45	65	100	μA	1
Outputs pin 2, 3, 4, 7 Reverse current $V_Q = V_S$	I_{CEO}			10	μA	2.6
Saturation voltage $I_Q = 2 \text{ mA}$	V_{sat}	0.1	0.4	2	V	2.6

Characteristics (cont'd)

$8 \leq V_S \leq 18 \text{ V}$; $-25 \text{ }^\circ\text{C} \leq T_A \leq 85 \text{ }^\circ\text{C}$; $f = 50 \text{ Hz}$

Parameter	Symbol	Limit Values			Unit	Test Circuit
		min.	typ.	max.		
Outputs pin 14, 15 H-output voltage – $I_Q = 250 \text{ mA}$	$V_{14/15 \text{ H}}$	$V_S - 3$	$V_S - 2.5$	$V_S - 1.0$	V	3.6
L-output voltage $I_Q = 2 \text{ mA}$	$V_{14/15 \text{ L}}$	0.3	0.8	2	V	2.6
Pulse width (short pulse) S9 open	t_p	20	30	40	μs	1
Pulse width (short pulse) with C_{12}	t_p	530	620	760	$\mu\text{s}/\text{nF}$	1
Internal voltage control Reference voltage Parallel connection of 10 ICs possible	V_{REF}	2.8	3.1	3.4	V	1
TC of reference voltage	α_{REF}		2×10^{-4}	5×10^{-4}	1/K	1

Application Hints for External Components

		min		max	
Ramp capacitance	C_{10}	500 pF		$1 \mu\text{F}^1)$	The minimum and maximum values of I_{10} are to be observed
Triggering point	$t_{Tr} =$	$\frac{V_{11} \times R_9 \times C_{10}}{V_{REF} \times K}$		2)	
Charge current	$I_{10} =$	$\frac{V_{REF} \times K}{R_9}$		2)	Ramp voltage $V_{10 \max} = V_S - 2 V$ $V_{10} = \frac{V_{REF} \times K \times t}{R_9 \times C_{10}}$ 2)

Pulse Extension versus Temperature

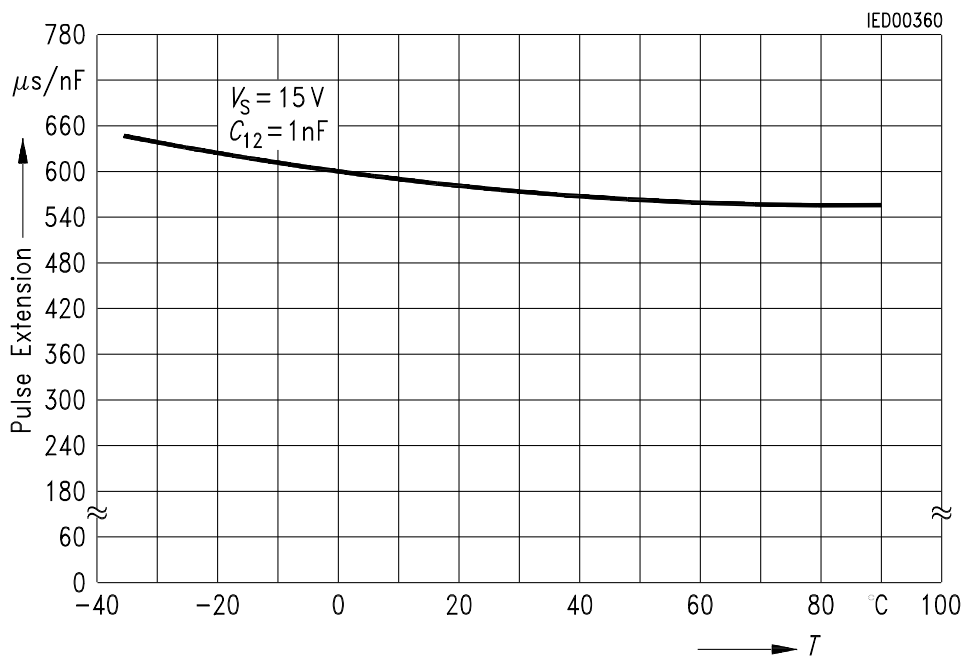

1) Attention to flyback times

2) $K = 1.10 \pm 20 \%$

Output Voltage measured to + V_S

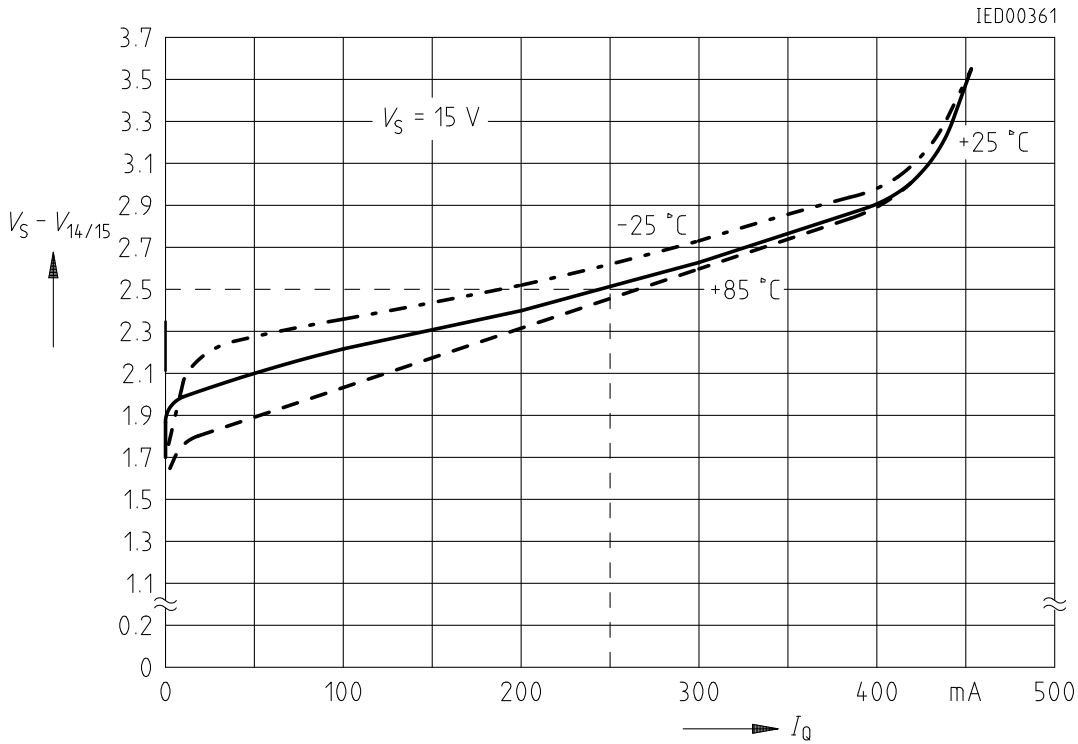

Supply Current versus Supply Voltage

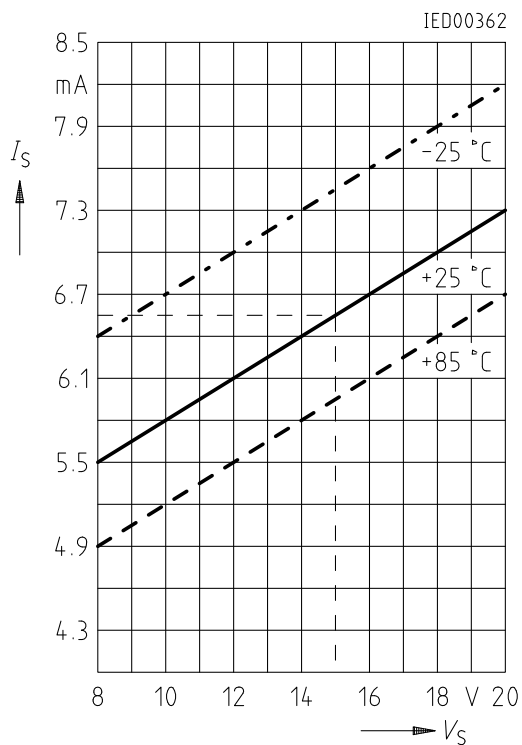

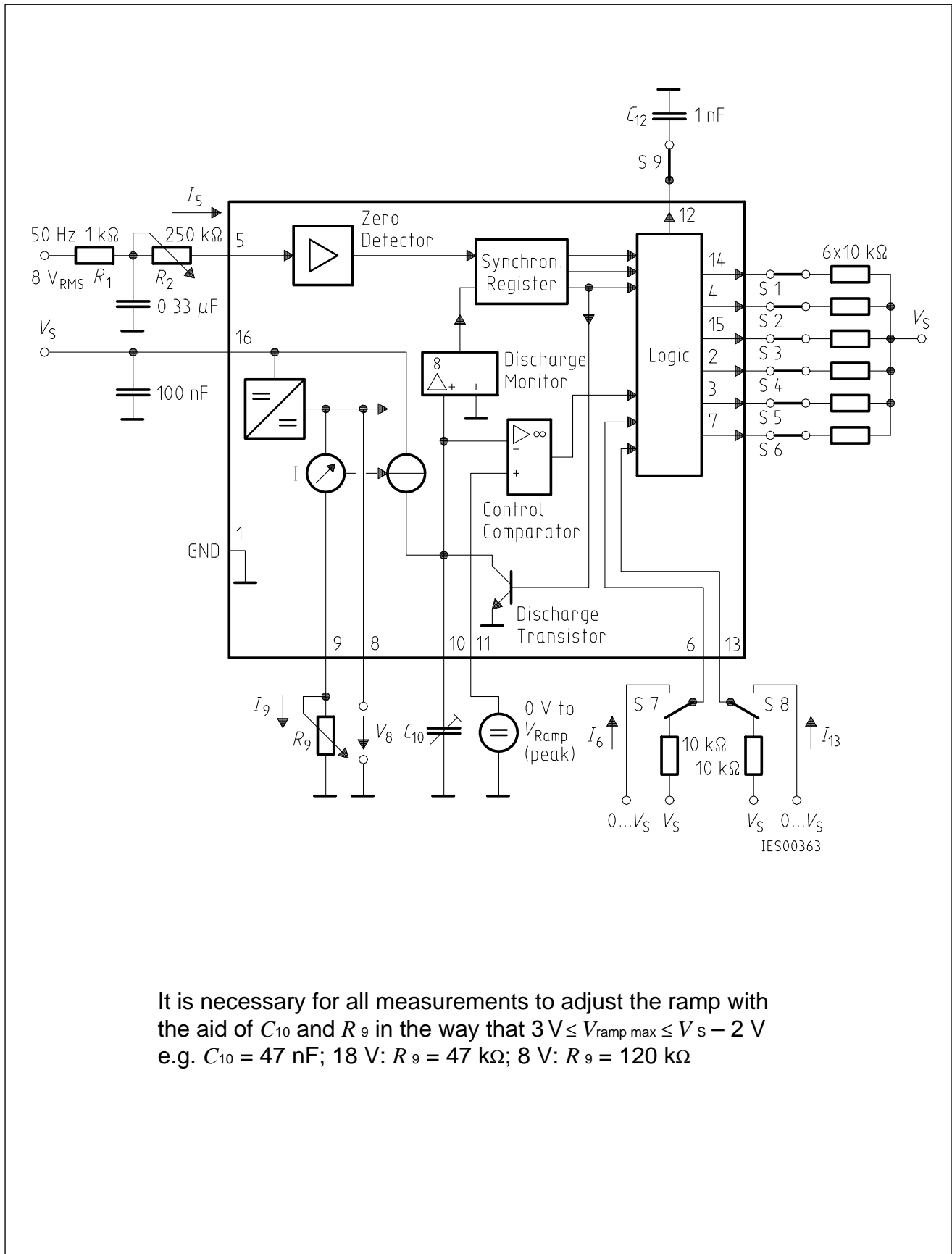

Test Circuit 1

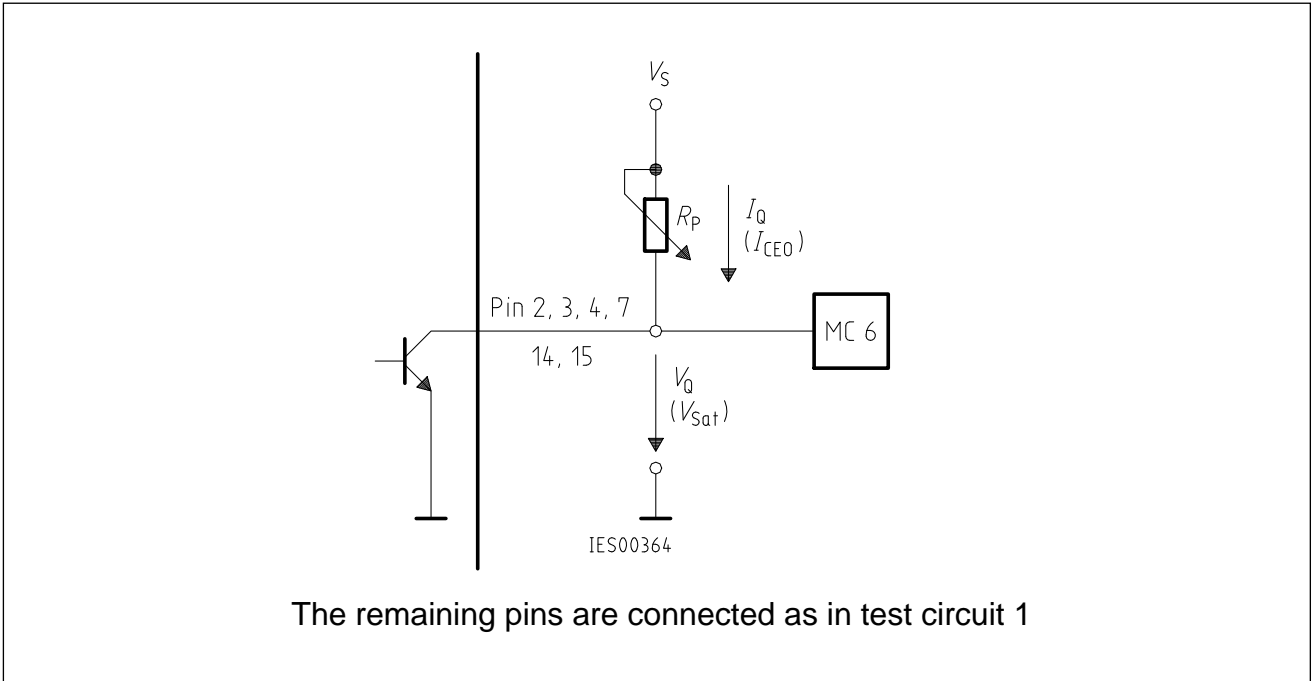

Test Circuit 2

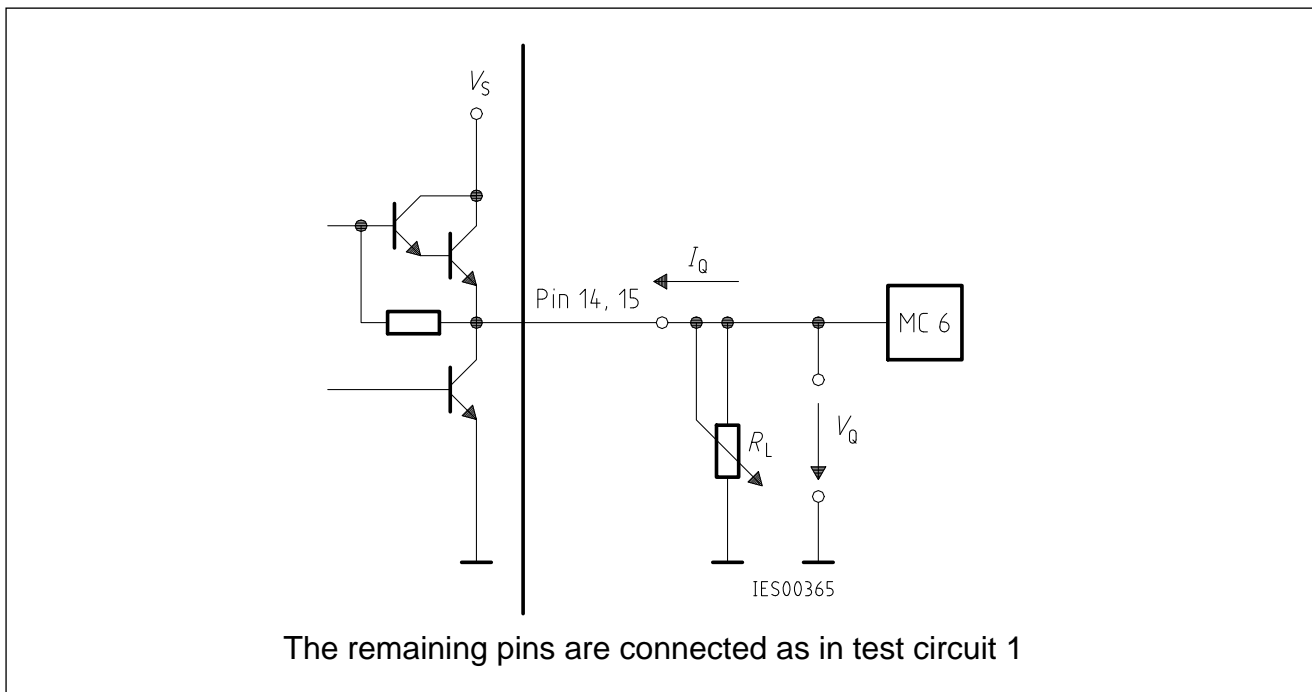

Test Circuit 3

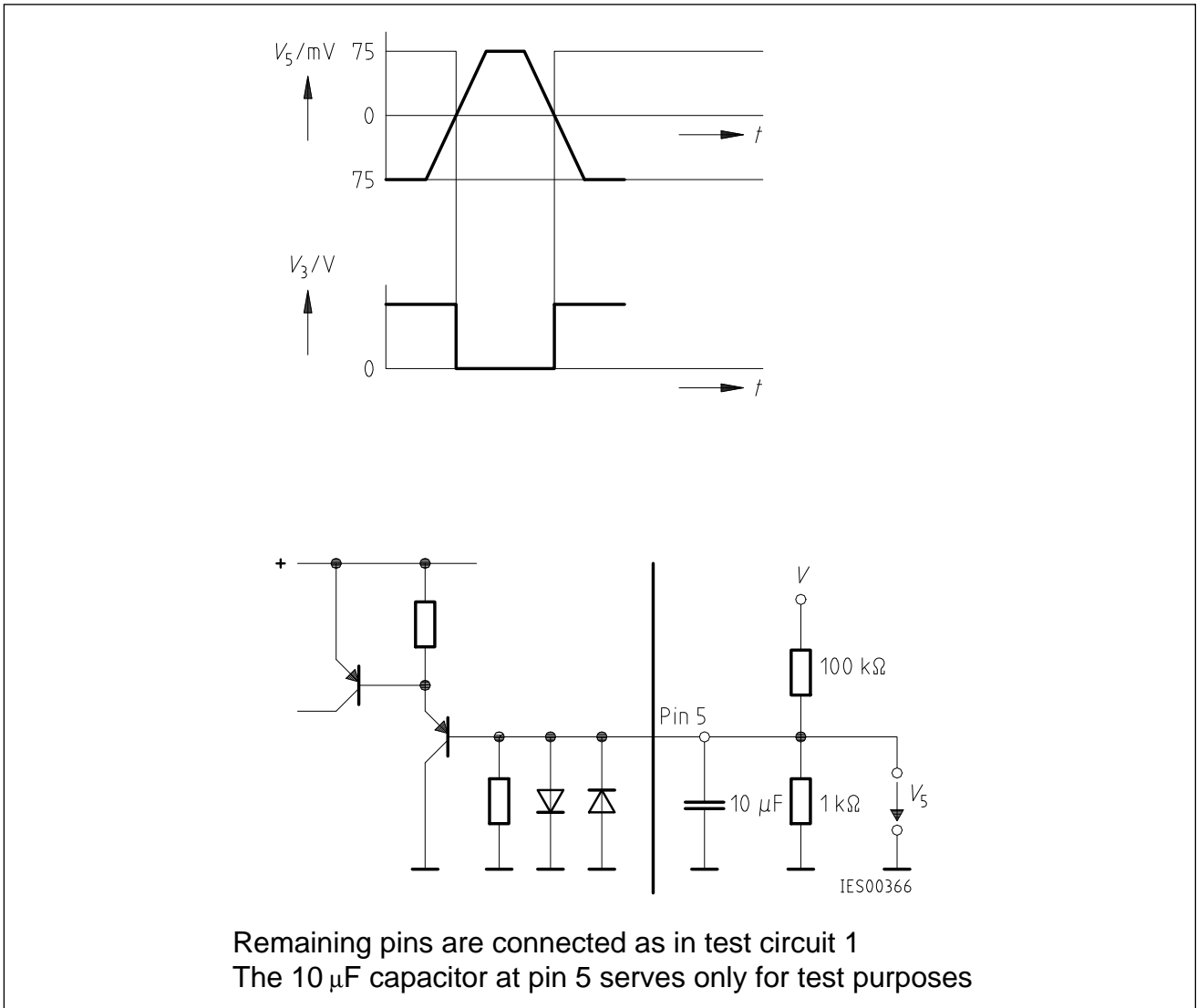

Test Circuit 4

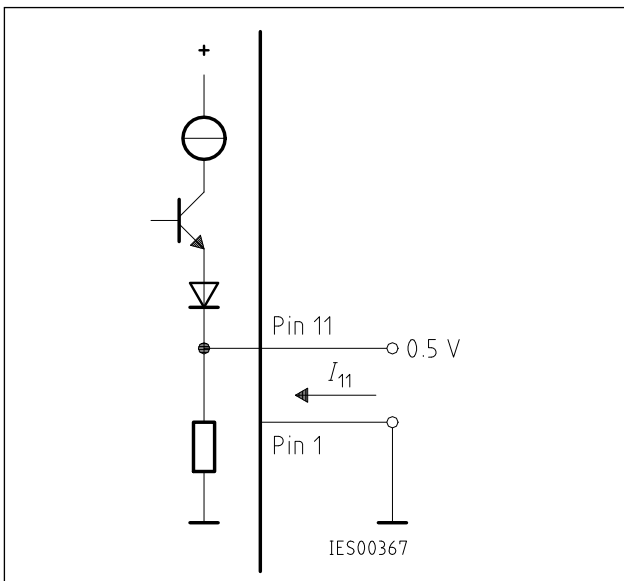

Test Circuit 5

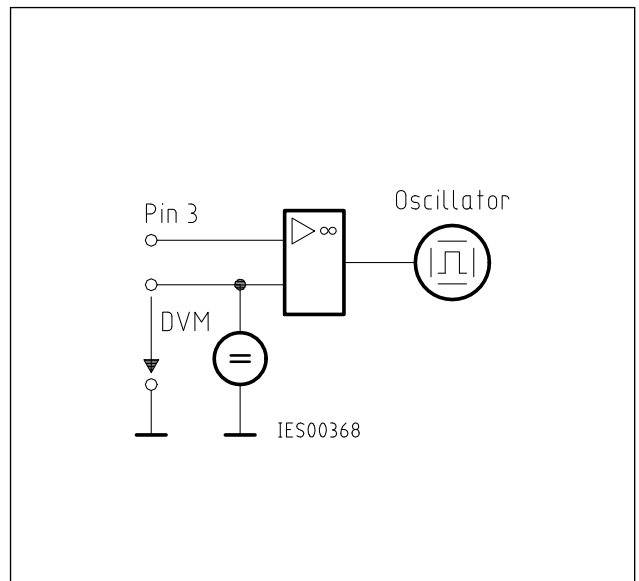

Test Circuit 6

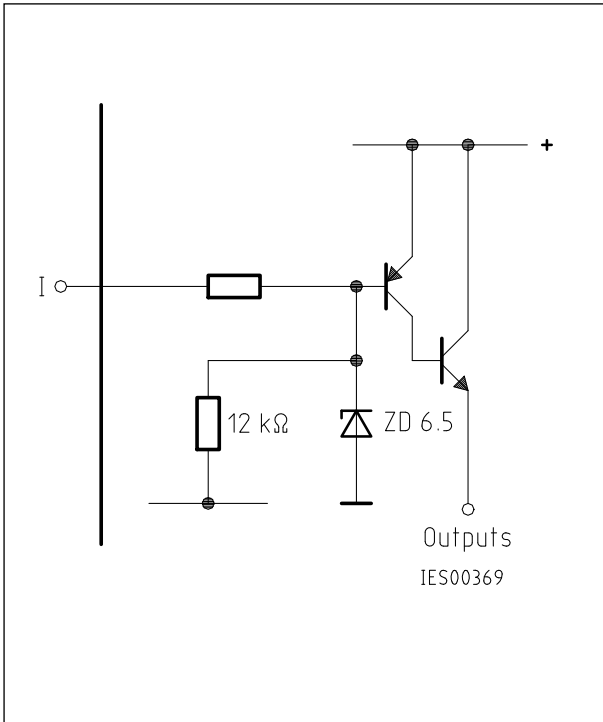

Inhibit 6

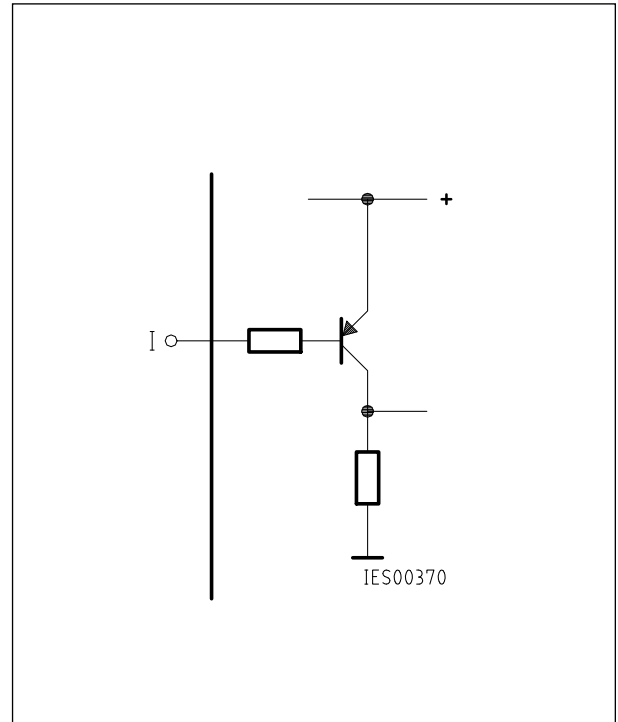

Long Pulse 13

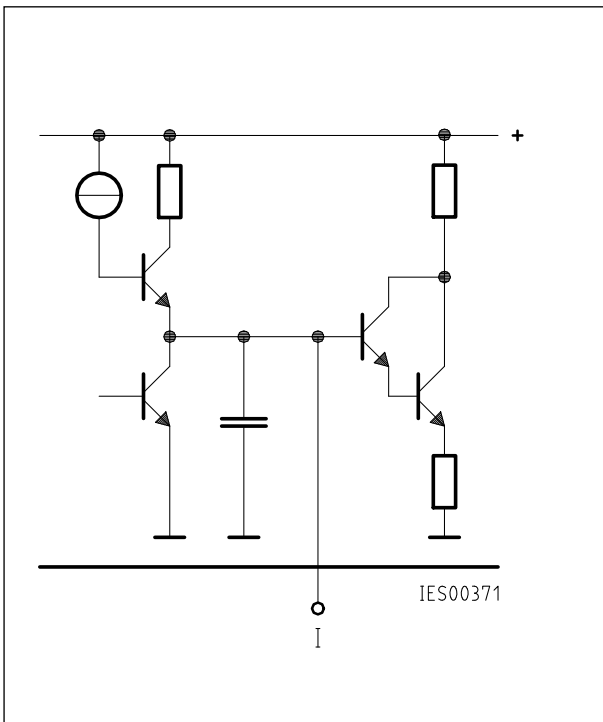

Pulse Extension 12

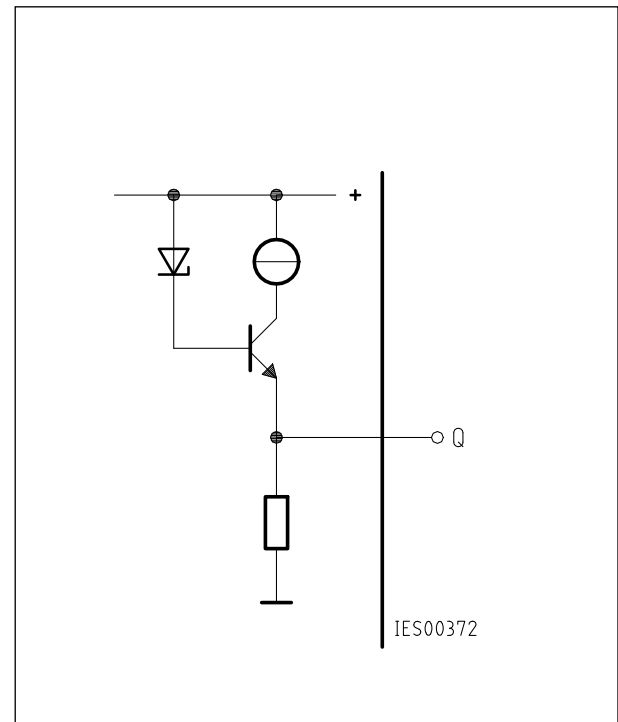

Reference Voltage 8

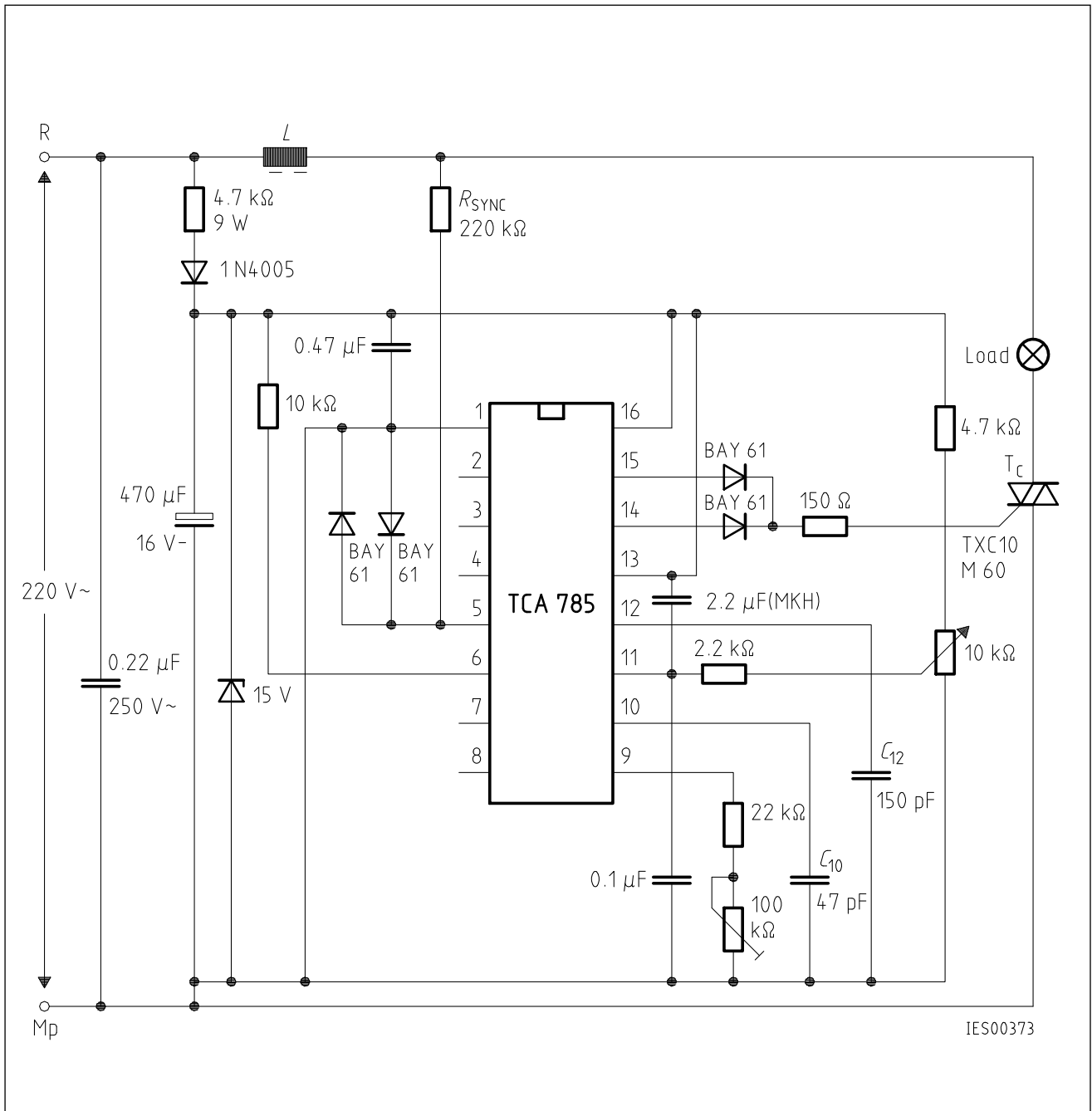

Application Examples
Triac Control for up to 50 mA Gate Trigger Current

A phase control with a directly controlled triac is shown in the figure. The triggering angle of the triac can be adjusted continuously between 0° and 180° with the aid of an external potentiometer. During the positive half-wave of the line voltage, the triac receives a positive gate pulse from the IC output pin 15. During the negative half-wave, it also receives a positive trigger pulse from pin 14. The trigger pulse width is approx. 100 μs.

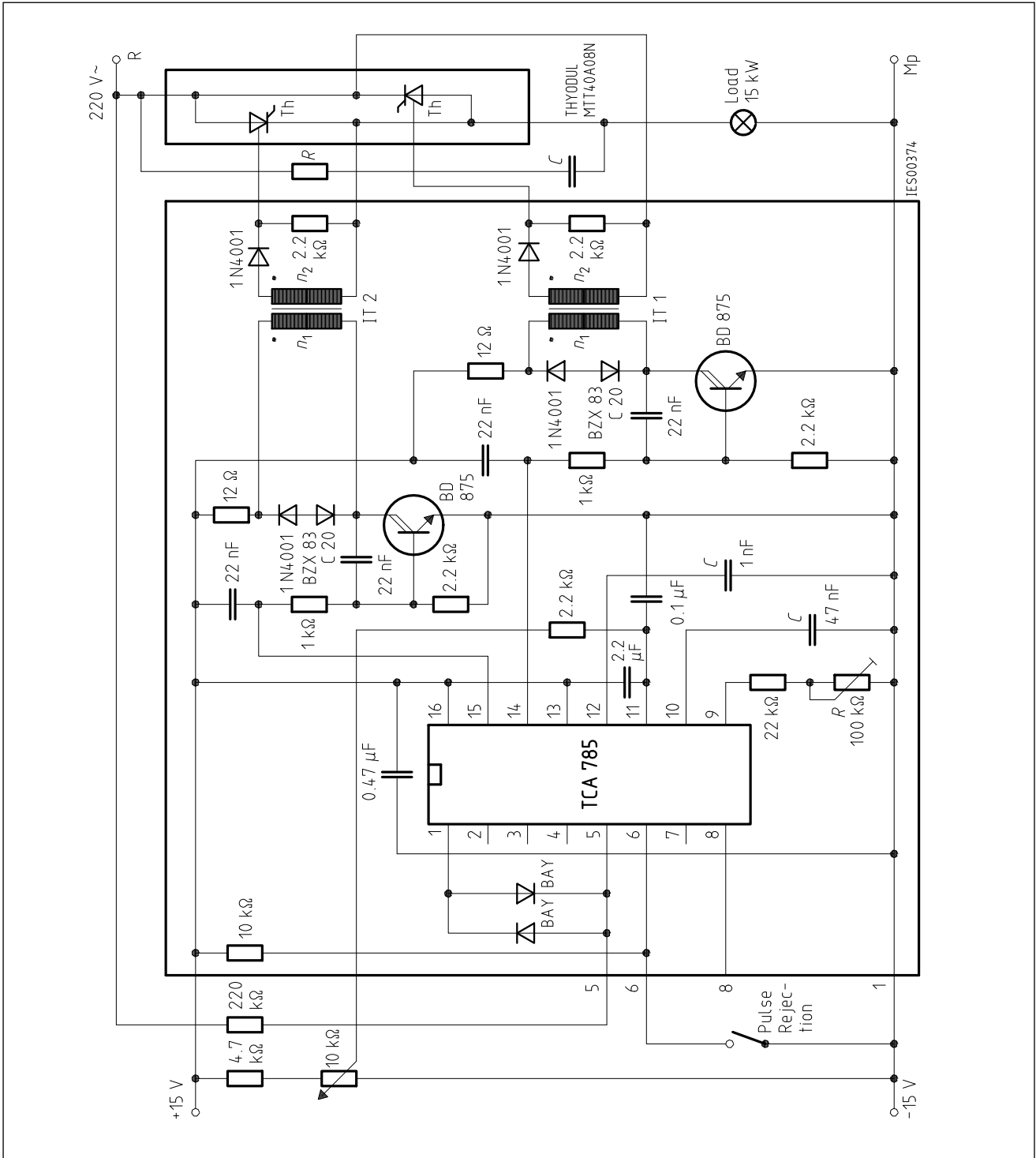

**Fully Controlled AC Power Controller
Circuit for Two High-Power Thyristors**

Shown is the possibility to trigger two antiparalleled thyristors with one IC TCA 785. The trigger pulse can be shifted continuously within a phase angle between 0° and 180° by means of a potentiometer. During the negative line half-wave the trigger pulse of pin 14 is fed to the relevant thyristor via a trigger pulse transformer. During the positive line half-wave, the gate of the second thyristor is triggered by a trigger pulse transformer at pin 15.

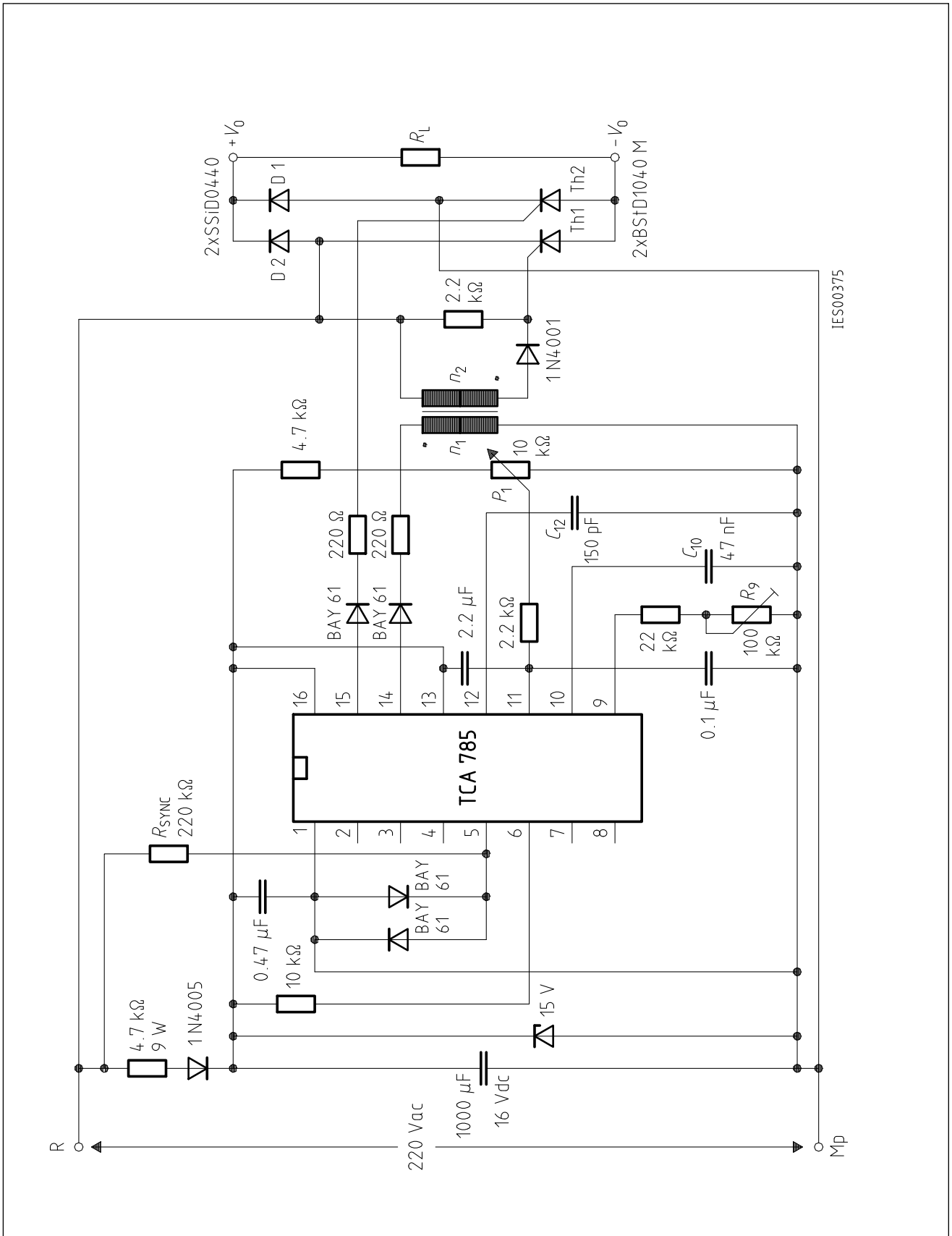

Half-Controlled Single-Phase Bridge Circuit with Trigger Pulse Transformer and Direct Control for Low-Power Thyristors

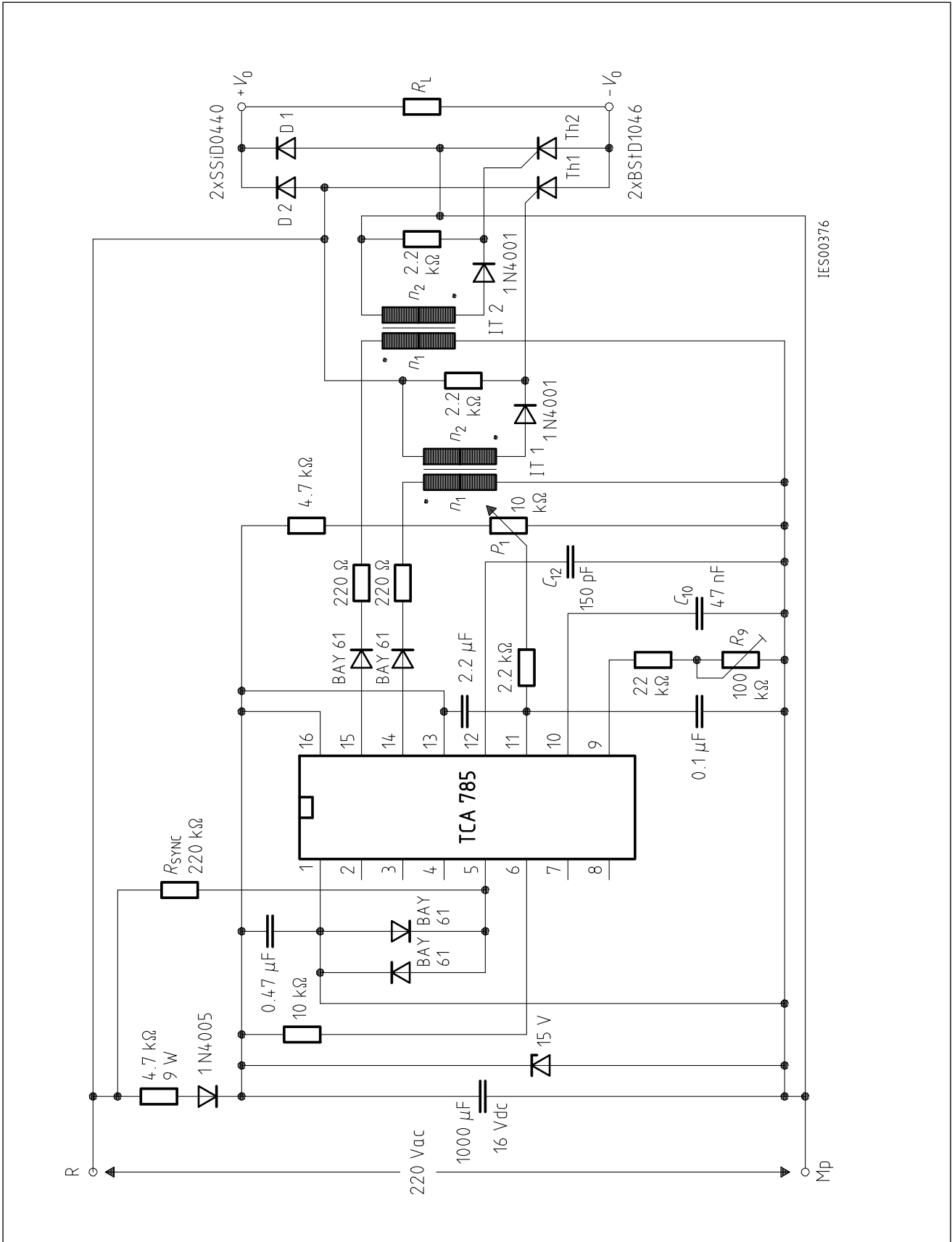

Half-Controlled Single-Phase Bridge Circuit with Two Trigger Pulse Transformers for Low-Power Thyristors