

PRODUCT NUMBER
SEE TABLE

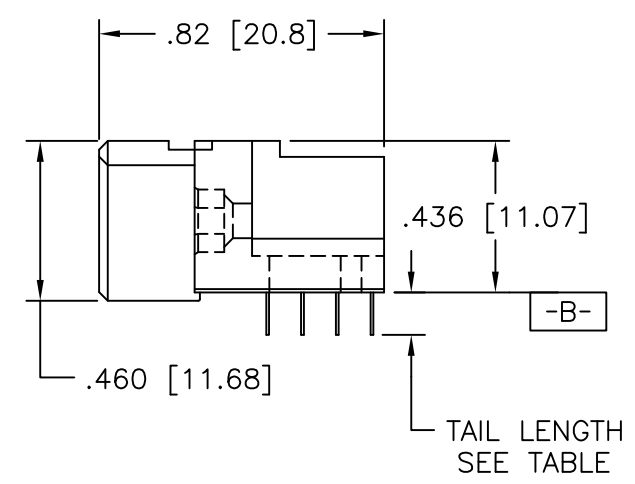
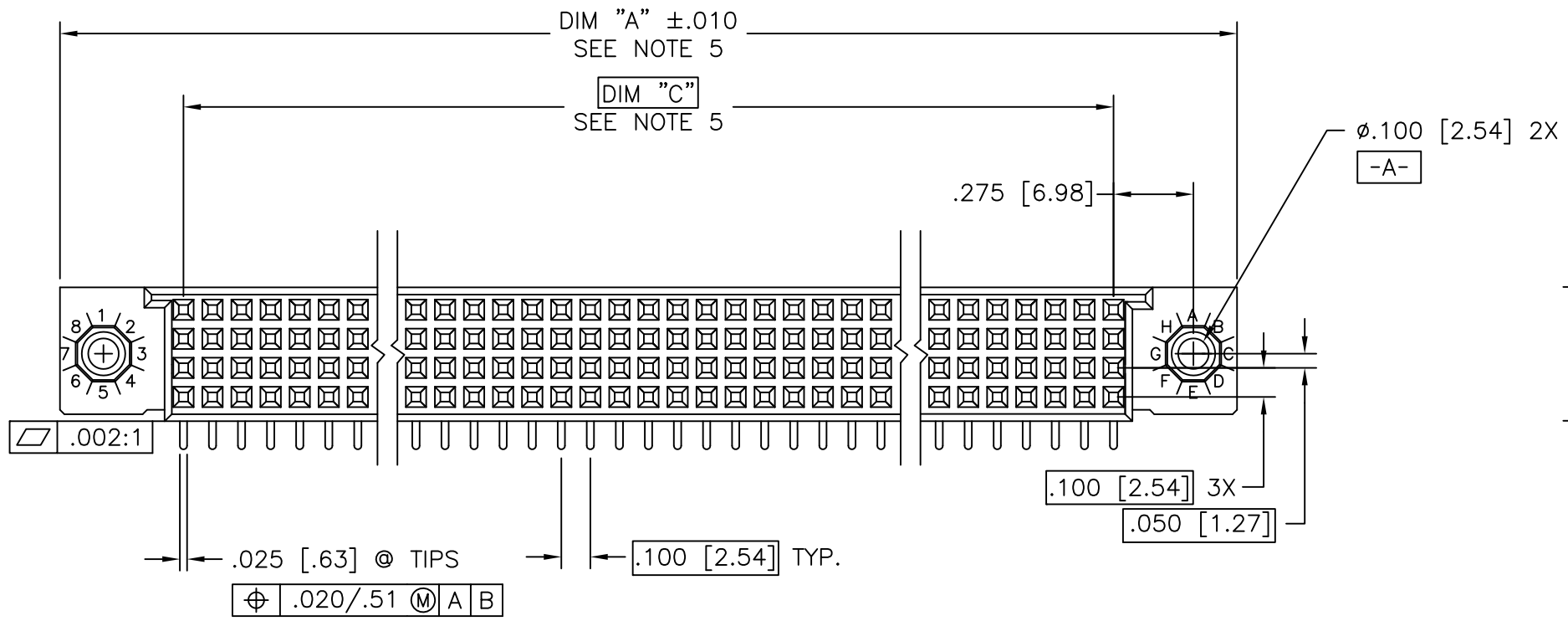
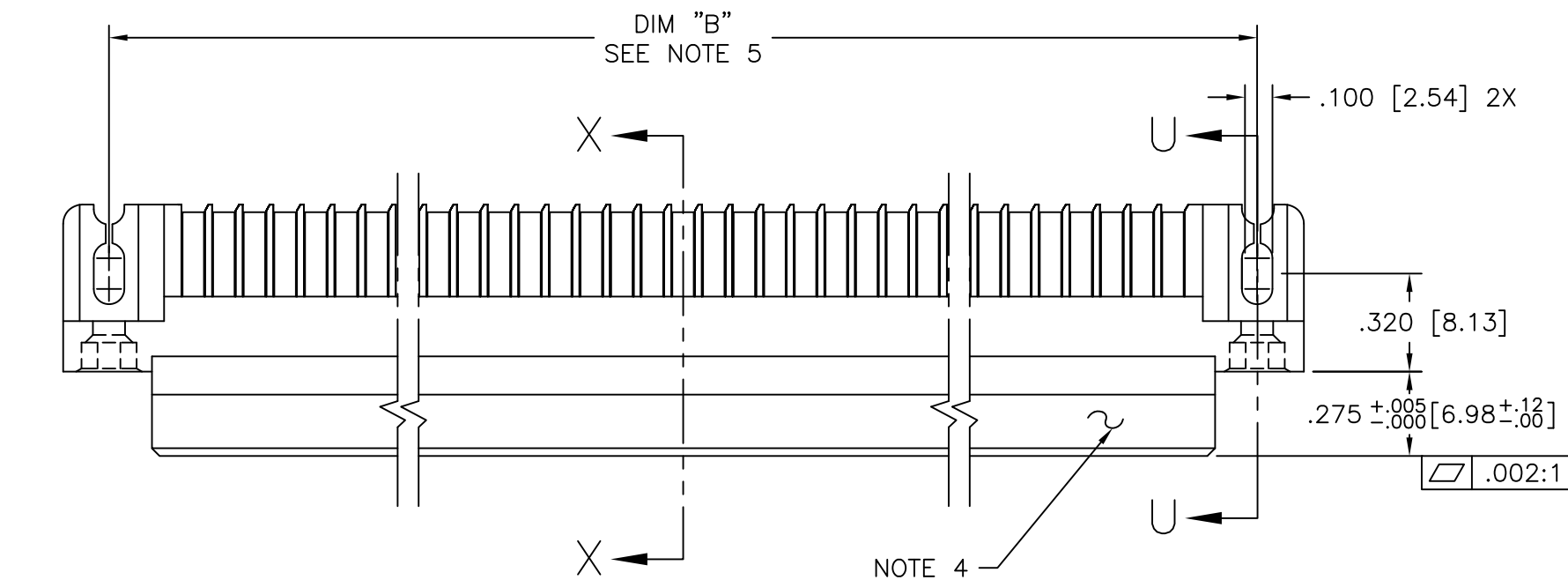

mat'l. code SEE NOTE 3				surface ISO 1302 ✓		tolerance ISO 406 ISO 1101		projection INCH/MM		product family HPC			
ltr	ecn no	dr	date	tolerances unless otherwise specified						title			
T	ELX-I-25681	MJA	12/16/16	angles	linear	.XX±.01/.X±0.3		INCH/MM	4 ROW R/A RECEPTACLE				
U	ELX-I-26885	MJA	05/03/17			.XXX±.005/.XX±0.13			SOLDER TAIL, 0 GUIDE PIN				
-	-	-	-	0°±2'		.XXX±.0020/.XXX±0.051		scale 1:1		type Product Customer Drawing			
N	V05-0513	DAI	10/19/05	dr	D.SHEAFER	1/7/90		Amphenol FCi		dwg no		sheet 1 of 4	size
P	M06-0283	MHT	7/27/06	enr	S.CLARK	1/7/90				50003		A3	
R	M07-0136	AGS	2/26/07	chr	M JACOB	05/03/17							
S	M08-0280	AGS	9/30/08	appd	BIJU K PAUL	05/03/17							
sheet index	revision sheet	U	T	T	T	T	T						
		1	2	3	4								

Amphenol
FCi

Copyright AFci

PRODUCT NUMBER
SEE TABLE

NOTES:
1. PRODUCT NUMBERING CODE:
50003 - X YYY Z LF
LEAD FREE (OPTIONAL)
TAIL LENGTH SEE TABLE
NO. OF POSITIONS SEE NOTE 2
PLATING SEE TABLE
BASE NUMBER

PRODUCT NUMBERING CODE FOR
SELECT LOAD PART NUMBERS:
50003 - XXYYY LF
LEAD FREE (OPTIONAL)
SEQUENCE NUMBER
ALWAYS 'XX'
BASE NUMBER

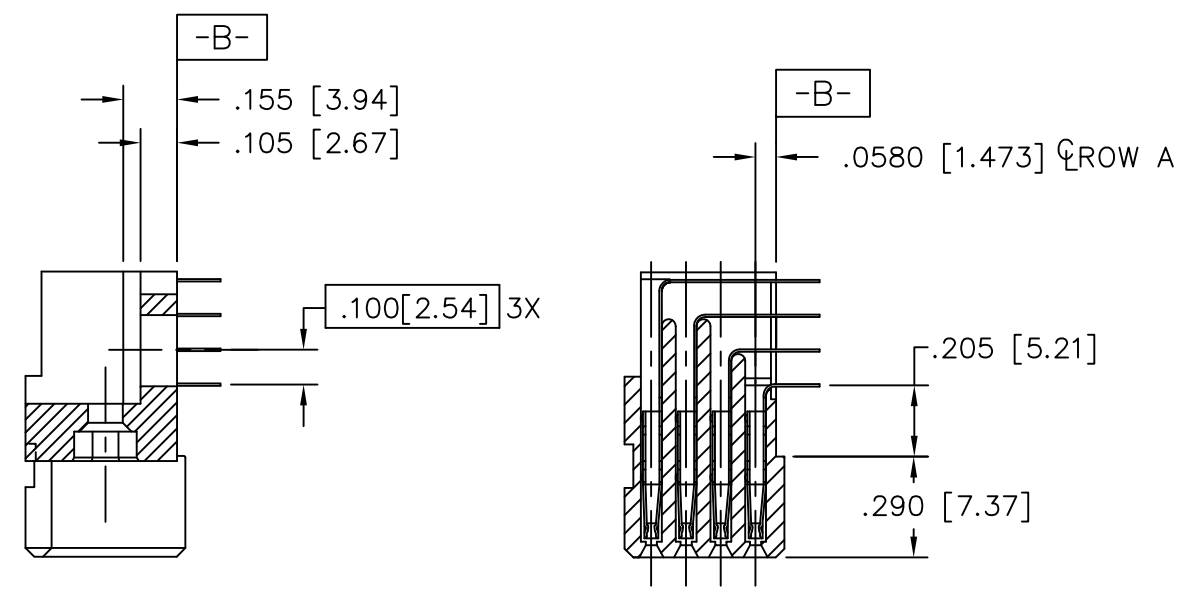

SECTION U-U

SECTION X-X

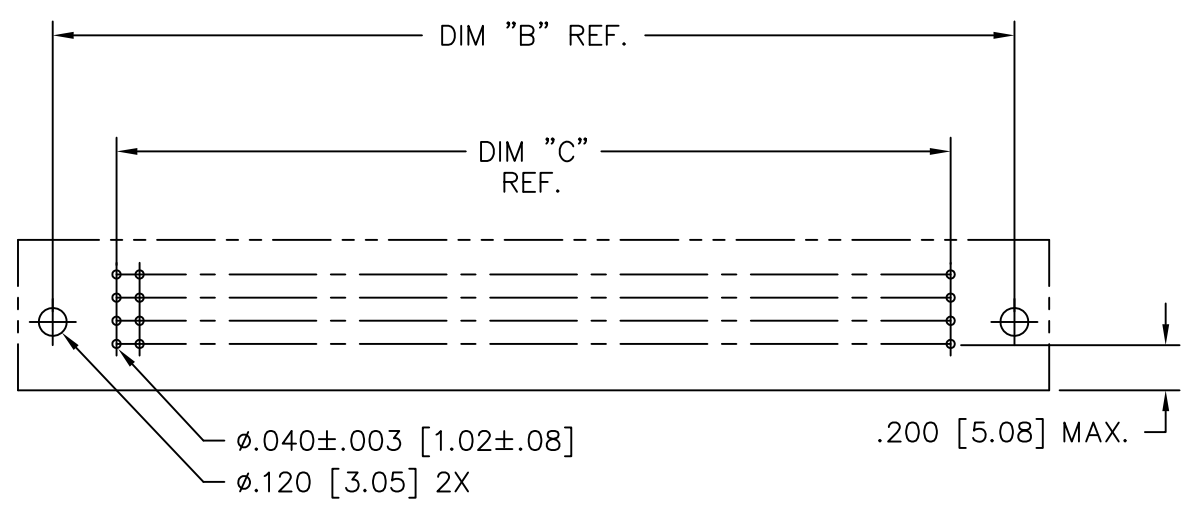

RECOMMENDED PCB LAYOUT
(ALL HOLES LOCATED ON .100 [2.54] GRID
UNLESS OTHERWISE SPECIFIED)

- ② THIS PRODUCT IS CONFIGURED IN SIZES OF 6 THRU 80 COLUMNS IN INCREMENTS OF ONE. i.e.: 6,7,8,9.....79,80.
- ③ HOUSING MATERIAL: GLASS AND MINERAL FILLED THERMOPLASTIC. CONTACT MATERIAL: BeCu
- ④ COMPANY NAME, PART NUMBER AND LOT CODE TO APPEAR ON THIS SURFACE PER BUS-12-108.
- ⑤ LENGTH FORMULAS
DIM A= .100/2.54 X NO. OF COLUMNS + .75/19.1
DIM B= .100/2.54 X NO. OF COLUMNS + .450/11.43
DIM C= .100/2.54 X NO. OF COLUMNS - .100/2.54
- 6. PRODUCT WITH 'LF' SUFFIX MEETS EUROPEAN UNION DIRECTIVES AND OTHER COUNTRY REGULATIONS AS DISCRIBED IN GS-22-008.
- 7. THIS HOUSING WILL WITHSTAND EXPOSURE TO 260° C PEAK TEMPERATURE FOR 10-30 SECONDS IN CONVECTION, INFRA-RED OR VAPOR PHASE REFLOW OVEN.
- ⑧ PLATING OPTION:
MAY BE EITHER GOLD OR GXT PLATED AT MANUFACTURER'S OPTION.

mat'l. code SEE NOTE 3		surface ISO 1302 ✓	tolerance ISO 406 ISO 1101	projection 	product family HPC
ltr	ecn no	dr	date	tolerances unless otherwise specified	title 4 ROW R/A RECEPTACLE SOLDER TAIL, 0 GUIDE PIN
T				linear XX±.01/XX±0.3 XXX±.005/XX±0.13 XXXX±.0020/XXX±0.051	
		angles 0°±2°		INCH/MM scale 1:1	dwg no 50003
		dr D.SHEAFER	1/7/90	Amphenol FCi	sheet 2 of 4 size A3
		enr S.CLARK	1/7/90		type Product Customer Drawing
		chr M JACOB	12/16/16		
		appd BIJU K PAUL	12/16/16		
sheet index	revision sheet				

PRODUCT NUMBER
SEE TABLE

50003-XX002LF ONLY

	75	70						65						60						55						50						45						40						36
<u>D</u>	D	D	D	D	D	D	D	D	D	D	D	D	D	D	D	D	D	D	D	D	D	D	D	D	D	D	D	D	D	D	D	D	D	D	D	D	D	D	D	D	D	D		
<u>C</u>	C	C	C	C	C	C	C	C	C	C	C	C	C	C	C	C	C	C	C	C	C	C	C	C	C	C	C	C	C	C	C	C	C	C	C	C	C	C	C	C	C			
<u>B</u>	B	B	B	B	B	B	B	B	B	B	B	B	B	B	B	B	B	B	B	B	B	B	B	B	B	B	B	B	B	B	B	B	B	B	B	B	B	B	B	B	B			
<u>A</u>	A	A	A	A	A	A	A	A	A	A	A	A	A	A	A	A	A	A	A	A	A	A	A	A	A	A	A	A	A	A	A	A	A	A	A	A	A	A	A	A				

	35	30						25						20						15						10						5						1			
<u>D</u>	D	D	D	D	D	D	D	D	D	D	D	D	D	D	D	D	D	D	D	D	D	D	D	D	D	D	D	D	D	D	D	D	D	D	D	D	D	D	D	D	D
<u>C</u>	C	C	C	C	C	C	C	C	C	C	C	C	C	C	C	C	C	C	C	C	C	C	C	C	C	C	C	C	C	C	C	C	C	C	C	C	C	C	C	C	
<u>B</u>	B	B	B	B	B	B	B	B	B	B	B	B	B	B	B	B	B	B	B	B	B	B	B	B	B	B	B	B	B	B	B	B	B	B	B	B	B	B	B	B	B
<u>A</u>	A	A	A	A	A	A	A	A	A	A	A	A	A	A	A	A	A	A	A	A	A	A	A	A	A	A	A	A	A	A	A	A	A	A	A	A	A	A	A	A	

TERM.
1

- NOTES FOR 50003-XX002LF ONLY:
1. ALL POSITIONS ARE LOADED AS SHOWN.
 2. COLUMN 1, ROW A IS DESIGNATED AS SIGNAL TERM. 1, AS VIEWED FROM THE MATING FACE.
 3. SIGNAL DATA FOR 50003-XX002LF
SIZE 4X 75
TOTAL NUMBER OF POSITIONS: 300
TOTAL NUMBER OF POSITIONS LOADED: 300

ITEM KEY	QTY.	TAIL LENGTH
A	75	.125 / 3.18
B	75	.125 / 3.18
C	75	.125 / 3.18
D	75	.125 / 3.18

mat'l. code SEE NOTE 3		surface ISO 1302 <input checked="" type="checkbox"/>		tolerance ISO 406 ISO 1101		projection 		product family HPC	
ltr		ecn no		dr		date		tolerances unless otherwise specified	
T								linear .XX±.01/.X±0.3 .XXX±.005/.XX±0.13 .XXXX±.0020/.XXX±0.051	
								INCH/MM scale 1:1	
		dr		D.SHEAFER		1/7/90		dwg no	
		enr		S.CLARK		1/7/90		sheet 3 of 4 size	
		chr		M JACOB		12/16/16		50003 A3	
		appd		BIJU K PAUL		12/16/16		type Product Customer Drawing	
sheet index		revision sheet							

Amphenol FCI
Copyright APCI

PRODUCT NUMBER	NUMBER OF POSITIONS SEE NOTE 2	TAIL LENGTH	CONTACT PLATING NOTE 9	TAIL PLATING
50003-1YYYE	YYY	.125±.010 / 3.18±0.25	30u" /0.76u Au	TIN/LEAD
50003-1YYYELF	YYY	.125±.010 / 3.18±0.25	30u" /0.76u Au	TIN
50003-1YYYF	YYY	.145±.010 / 3.68±0.25	30u" /0.76u Au	TIN/LEAD
50003-1YYYFLF	YYY	.145±.010 / 3.68±0.25	30u" /0.76u Au	TIN
50003-1YYYH	YYY	.180±.010 / 4.57±0.25	30u" /0.76u Au	TIN/LEAD
50003-1YYYHLF	YYY	.180±.010 / 4.57±0.25	30u" /0.76u Au	TIN
50003-3YYYE	YYY	.125±.010 / 3.18±0.25	50u" /1.27u Au	TIN/LEAD
50003-3YYYELF	YYY	.125±.010 / 3.18±0.25	50u" /1.27u Au	TIN
50003-3YYYF	YYY	.145±.010 / 3.68±0.25	50u" /1.27u Au	TIN/LEAD
50003-3YYYFLF	YYY	.145±.010 / 3.68±0.25	50u" /1.27u Au	TIN
50003-5YYYE	YYY	.125±.010 / 3.18±0.25	30u" /0.76u GXT	TIN/LEAD
50003-5YYYELF	YYY	.125±.010 / 3.18±0.25	30u" /0.76u GXT	TIN
50003-5YYYF	YYY	.145±.010 / 3.68±0.25	30u" /0.76u GXT	TIN/LEAD
50003-5YYYFLF	YYY	.145±.010 / 3.68±0.25	30u" /0.76u GXT	TIN
50003-5YYYH	YYY	.180±.010 / 4.57±0.25	30u" /0.76u GXT	TIN/LEAD
50003-5YYYHLF	YYY	.180±.010 / 4.57±0.25	30u" /0.76u GXT	TIN
50003-XX002LF	YYY	.125±.010 / 3.18±0.25	30u" /0.76u Au	TIN

Amphenol
FCi

Copyright AFci

mat'l. code SEE NOTE 3				surface ISO 1302 ✓	tolerance ISO 406 ISO 1101	projection 	product family HPC
ltr	ecn no	dr	date	tolerances unless otherwise specified		INCH/MM scale 1:1	title 4 ROW R/A RECEPTACLE SOLDER TAIL, 0 GUIDE PIN
T				angles	linear		
				0°±2°	.XX±.01/.X±0.3 .XXX±.005/.XX±0.13 .XXXX±.0020/.XXX±0.051		
		dr	D.SHEAFER	1/7/90		Amphenol FCi	dwg no
		enr	S.CLARK	1/7/90			sheet 4 of 4 size
		chr	M JACOB	12/16/16			50003
		appd	BIJU K PAUL	12/16/16			A3
sheet index		revision sheet					type Product Customer Drawing