

DATE	DESCRIPTION	REV.

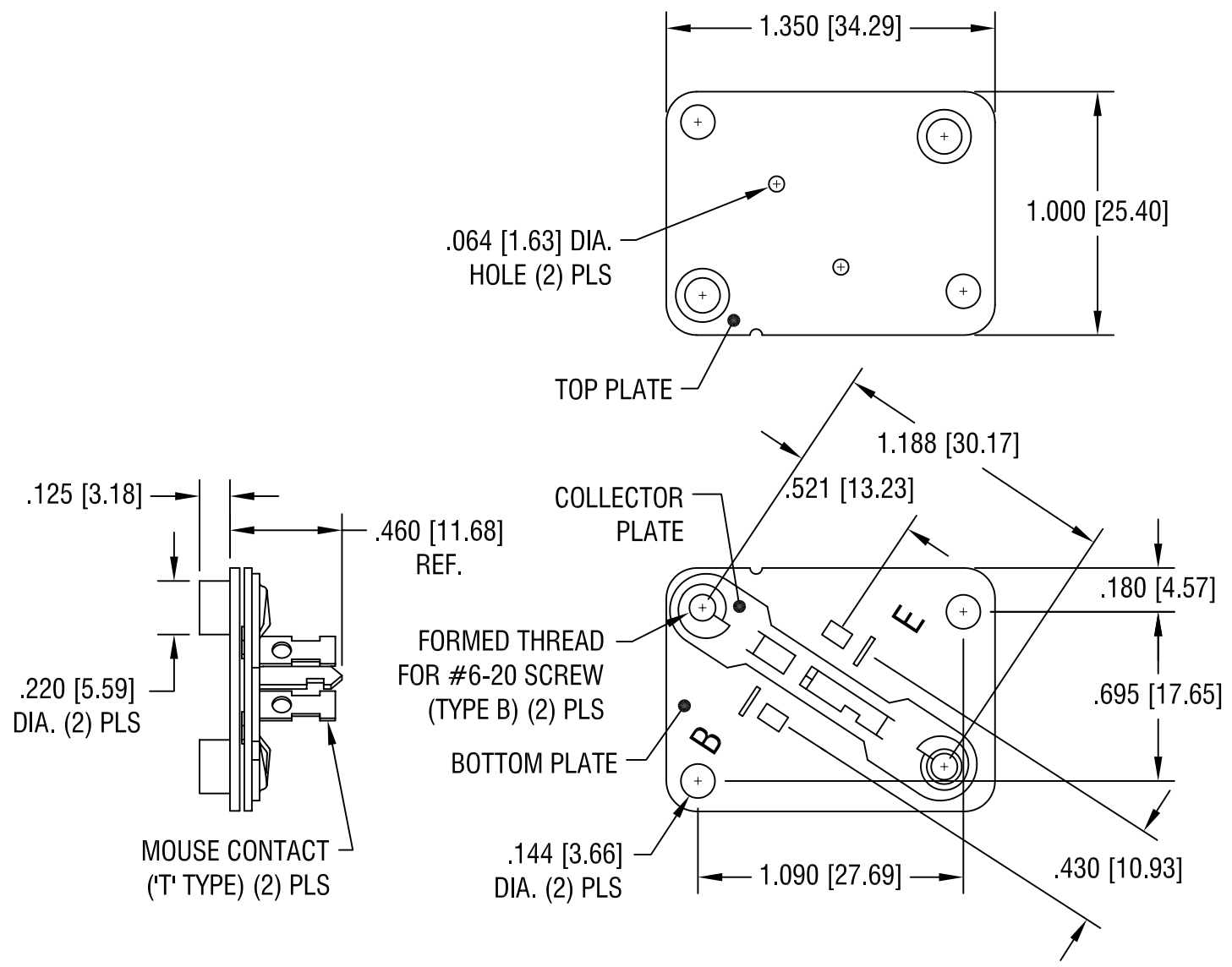

**NOTES:**

TOP PLATE: COLOR - RED  
 MAT'L - NYLON 6/6 UL 94V-2

BOTTOM PLATE:  
 MAT'L - .032 [0.81] TH'K PHENOLIC

COLLECTOR PLATE:  
 MAT'L - .032 [0.81] TH'K STEEL  
 FINISH - TIN PLATE

MOUSE CONTACT ('T' TYPE):  
 MAT'L - .013 [0.33] TH'K BRASS  
 FINISH - TIN PLATE

<b>KEYSTONE ELECTRONICS CORP.</b>			
ASTORIA, N.Y. 11105-2017			
PART NAME			
TO-3 POWER TRANSISTOR SOCKET			
MATERIAL			
AS NOTED			
FINISH		DRN BY	DATE
AS NOTED		BOONE	3.14.07
		APPD	SCALE
		LN	1.5X
TOLERANCES	INCH [MM]	CODE	DWG NO.
DECIMAL	± .005 [± 0.15]	C	<b>4618</b>
ANGULAR	± 1°		
UNLESS OTHERWISE SPECIFIED			

THIS DOCUMENT IS THE PROPERTY OF KEYSTONE ELECTRONICS CORP. AND SHALL NOT BE REPRODUCED, DISTRIBUTED OR USED AS A BASIS FOR MANUFACTURE WITHOUT PRIOR WRITTEN PERMISSION FROM KEYSTONE ELECTRONICS CORP.