

**OBSOLETE PRODUCT
NO RECOMMENDED REPLACEMENT**

3-3/4 Digit, Autoranging Multimeter

The Intersil ICL7149 is a high performance, low power, autoranging digital multimeter IC. Unlike other autoranging multimeter ICs, the ICL7149 always displays the result of a conversion on the correct range. There is no “range hunting” noticeable in the display. The unit will autorange between the four different ranges. A manual switch is used to select the 2 high group ranges. DC current ranges are 4mA and 40mA in the low current group, and 400mA and 4A in the high current group. Resistance measurements are made on 4 ranges, which are divided into two groups. The low resistance ranges are 4/40kΩ. The high resistance ranges are 0.4/4MΩ. Resolution on the lowest range is 1Ω.

Part Number Information

PART NUMBER	TEMP. RANGE (°C)	PACKAGE	PKG. NO.
ICL7149CM44	0 to 70	44 Ld MQFP	Q44.10x10

Pinout

ICL7149 (MQFP)
TOP VIEW

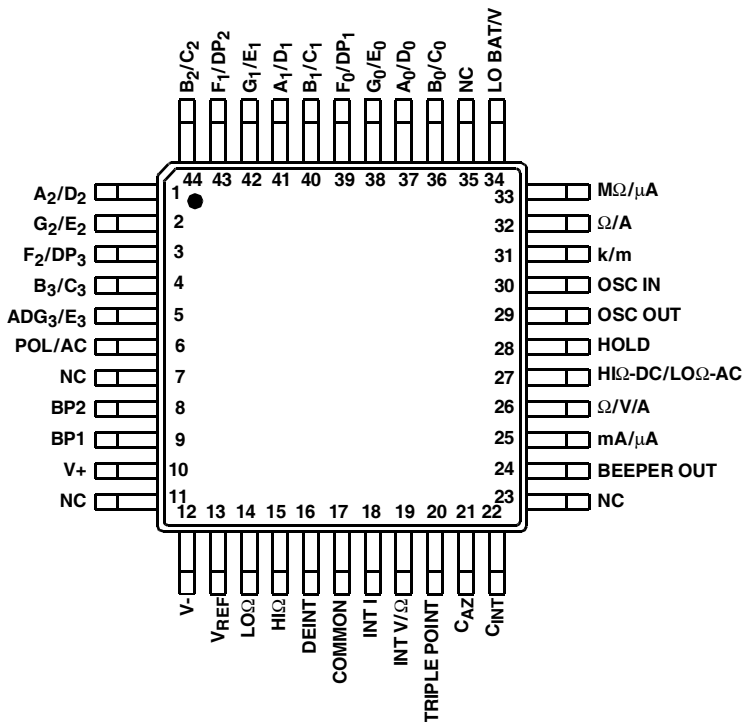

Features

- 18 Ranges
 - 4 DC Voltage 400mV, 4V, 40V, 400V
 - 2 AC Voltage with Optional AC Circuit
 - 4 DC Current 4mA, 40mA, 400mA, 4A
 - 4 AC Current with Optional AC Circuit
 - 4 Resistance 4kΩ, 40kΩ, 400kΩ, 4MΩ
- Autoranging - First Reading is Always on Correct Range
- On-Chip Duplex LCD Display Drive Including Three Decimal Points and 11 Annunciators
- No Additional Active Components Required
- Low Power Dissipation - Less than 20mW - 1000 Hour Typical Battery Life
- Display Hold Input
- Continuity Output Drives Piezoelectric Beeper
- Low Battery Annunciator with On-Chip Detection
- Guaranteed Zero Reading for 0V Input on All Ranges

Related Literature

- Technical Brief TB363 “Guidelines for Handling and Processing Moisture Sensitive Surface Mount Devices (SMDs)”

Functional Block Diagram

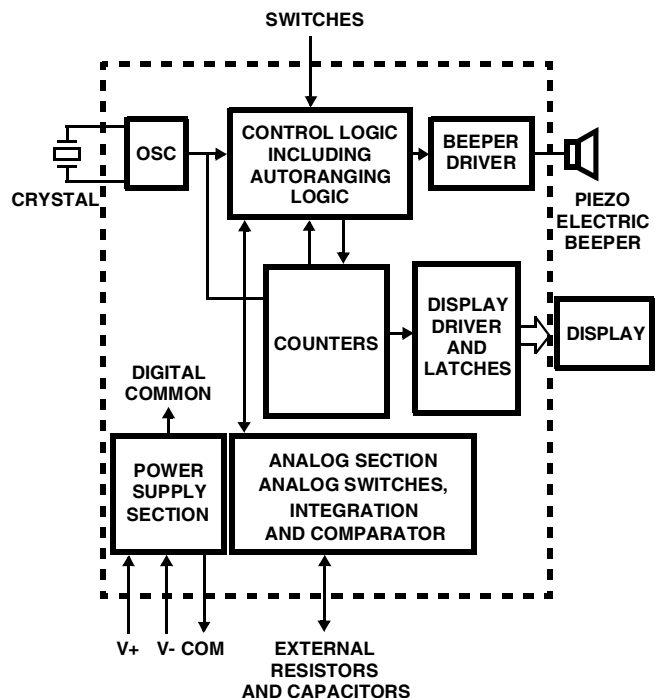

Absolute Maximum Ratings

Supply Voltage (V+ to V-)15V
 Reference Input Voltage (V_{REF} to COM)3V
 Analog Input Current (IN + Current or IN + Voltage)100μA
 Clock Input SwingV+ to V+ -3

Operating Conditions

Temperature Range.....0°C to 70°C

Thermal Information

Thermal Resistance (Typical, Note 1) θ_{JA} (°C/W)
 MQFP Package 80
 Maximum Junction Temperature150°C
 Maximum Storage Temperature Range -65°C to 150°C
 Maximum Lead Temperature (Soldering 10s)300°C
 (Lead Tips Only)

CAUTION: Stresses above those listed in "Absolute Maximum Ratings" may cause permanent damage to the device. This is a stress only rating and operation of the device at these or any other conditions above those indicated in the operational sections of this specification is not implied.

NOTE:

1. θ_{JA} is measured with the component mounted on a low effective thermal conductivity test board in free air. See Tech Brief TB379 for details.

Electrical Specifications V+ = 9V, T_A = 25°C, V_{REF} adjusted for -3.700 reading on DC volts, test circuit as shown in Figure 3. Crystal = 120kHz. (See Figure 13)

PARAMETER	TEST CONDITIONS	MIN	TYP	MAX	UNITS
Zero Input Reading	V _{IN} or I _{IN} or R _{IN} = 0.00	-00.0	-	+00.0	V, I, Ω
Linearity (Best Straight Line) (Note 6)	(Note 1)	-1	-	+1	Counts
Accuracy DC V, 400V Range Only	(Notes 1 and 7)	-	-	±1	% of RDG ±1
Accuracy DC V, 400V Range Excluded	(Notes 1 and 7)	-	-	±0.30	% of RDG ±1
Accuracy Ω, 4K and 400K Range	(Notes 1 and 7)	-	-	±0.75	% of RDG ±8
Accuracy Ω, 4K and 4M Range	(Notes 1 and 7)	-	-	±1	% of RDG ±9
Accuracy DC I, Unadjusted for Full Scale	(Notes 1 and 7)	-	-	±0.75	% of RDG ±1
Accuracy DC I, Adjusted for Full Scale	(Notes 1 and 7)	-	±0.2	-	% of RDG ±1
Accuracy AC V	At 60Hz (Notes 5 and 7)	-	±2	-	% of RDG
Open Circuit Voltage for Ω Measurements	R _{UNKNOWN} = Infinity	-	V _{REF}	-	V
Noise	V _{IN} = 0, DC V (Note 2, 95% of Time)	-	0.1	-	LSB
Noise	V _{IN} = 0, AC V (Note 2, 95% of Time)	-	4	-	LSB
Supply Current	V _{IN} = 0, DC Voltage Range	-	1.5	2.4	mA
Analog Common (with Respect to V+)	I _{COMMON} < 10μA	2.7	2.9	3.1	V
Temperature Coefficient of Analog Common	I _{COMMON} < 10μA, Temp. = 0°C To 70°C	-	-100	-	ppm/°C
Output Impedance of Analog Common	I _{COMMON} < 10μA	-	1	10	Ω
Backplane/Segment Drive Voltage	Average DC < 50mV	2.8	3.0	3.2	V
Backplane/Segment Display Frequency		-	75	-	Hz
Switch Input Current	V _{IN} = V+ to V- (Note 3)	-50	-	+50	μA
Switch Input Levels (High Trip Point)		V+ - 0.5	-	V+	V
Switch Input Levels (Mid Trip Point)		V- + 3	-	V+ - 2.5	V
Switch Input Levels (Low Trip Point)		V-	-	V- + 0.5	V
Beeper Output Drive (Rise or Fall Time)	C _{LOAD} = 10nF	-	25	100	μs
Beeper Output Frequency		-	2	-	kHz
Continuity Detect	Range = Low Ω, V _{REF} = 1.00V	-	1.5	-	kΩ
Power Supply Functional Operation	V+ to V-	7	9	11	V
Low Battery Detect	V+ to V- (Note 4)	6.5	7	7.5	V

NOTES:

1. Accuracy is defined as the worst case deviation from ideal input value including: offset, linearity, and rollover error.
2. Noise is defined as the width of the uncertainty window (where the display will flicker) between two adjacent codes.
3. Applies to pins 25-28.
4. Analog Common falls out of regulation when the Low Battery Detect is asserted, however the ICL7149 will continue to operate correctly with a supply voltage above 7V and below 11V.
5. For 50Hz use a 100kHz crystal.
6. Guaranteed by design, not tested.
7. RDG = Reading.

Timing Waveform

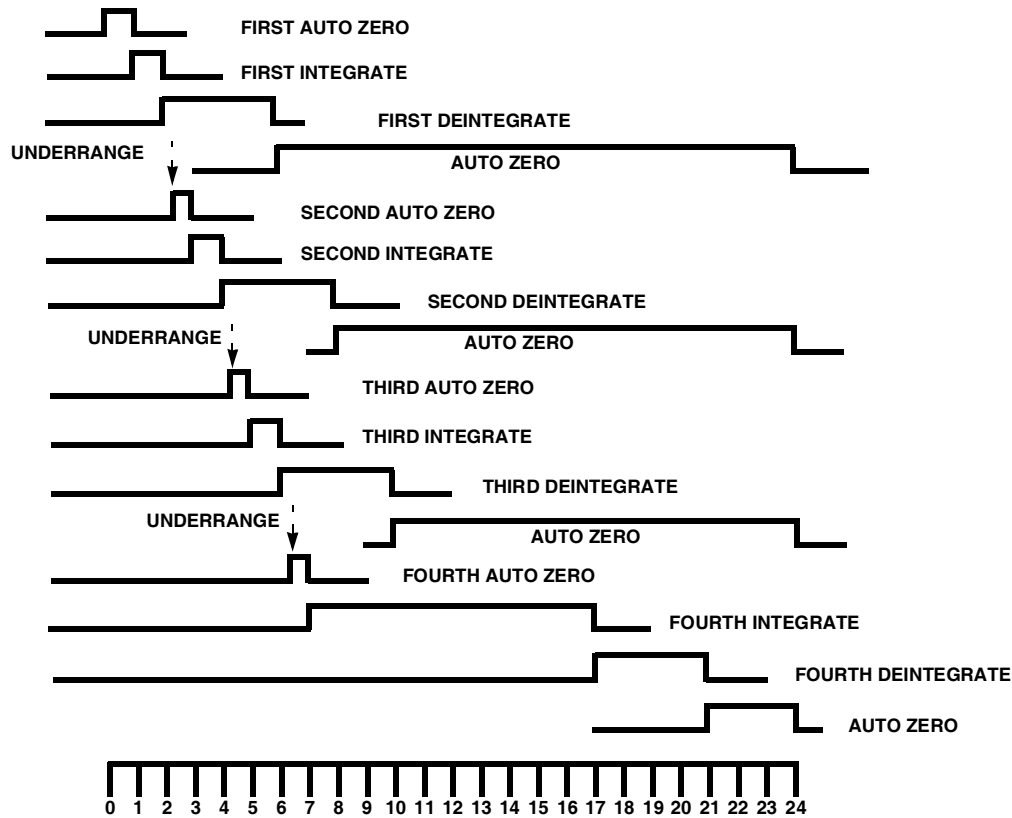

FIGURE 1. LINE FREQUENCY CYCLES (1 CYCLE = 1000 INTERNAL CLOCK PULSES = 2000 OSCILLATION CYCLES)

Pin Descriptions

I/O	PIN NUMBER	DESCRIPTION
O	1	Segment Driver A ₂ /D ₂
O	2	Segment Driver G ₂ /E ₂
O	3	Segment Driver F ₂ /DP ₃
O	4	Segment Driver B ₃ /C ₃
O	5	Segment Driver ADG ₃ /E ₃
O	6	Segment Driver POL/AC
N/A	7	No Connect (NC)
O	8	Backplane 2
O	9	Backplane 1
I	10	V+
N/A	11	NC
I	12	V-
I	13	Reference Input
O	14	Lo Ω
O	15	Hi Ω
I/O	16	Deintegrate
I/O	17	Analog Common
I	18	Int I
I	19	Int V/Ω
I	20	Triple Point
I	21	Auto Zero Capacitor (C _{AZ})
I	22	Integrate Capacitor (C _{INT})
N/A	23	NC

I/O	PIN NUMBER	DESCRIPTION
O	24	Beeper Output
I	25	mA/μA
I	26	Ω/V/A
I	27	Hi Ω DC/Lo Ω AC
I	28	Hold
O	29	Oscillator Out
I	30	Oscillator In
O	31	Segment DRIVER k/m
O	32	Segment Driver Ω/A
O	33	Segment Driver M.Ω/μA
O	34	Segment Driver Lo Bat/V
N/A	35	NC
O	36	Segment Driver B ₀ /C
O	37	Segment Driver A ₀ /D ₀
O	38	Segment Driver G ₀ /E ₀
O	39	Segment Driver F ₀ /DP ₁
O	40	Segment Driver B ₁ /C ₁
O	41	Segment Driver A ₁ /D ₁
O	42	Segment Driver G ₁ /E ₁
O	43	Segment Driver F ₁ /DP ₂
O	44	Segment Driver B ₂ /C ₂

NOTE: For segment drivers, segments are listed as (segment for backplane 1)/(segment for backplane 2). Example: pin 36; segment B₀ is on backplane 1, segment C₀ is on backplane 2.

Detailed Description

General

The Functional Block Diagram shows the digital section which includes all control logic, counters, and display drivers. The digital section is powered by V+ and Digital Common, which is about 3V below V+. The oscillator is also in the digital section. Normally 120kHz for rejection of 60Hz AC interference and 100kHz for rejection of 50Hz AC should be used. The oscillator output is divided by two to generate the internal master clock. The analog section contains the integrator, comparator, reference section, analog buffers, and several analog switches which are controlled by the digital logic. The analog section is powered from V+ and V-.

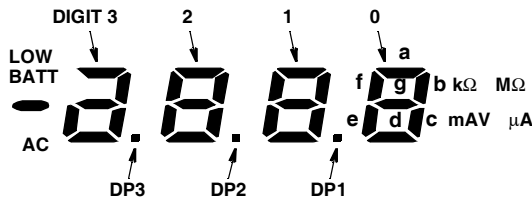

FIGURE 2. DISPLAY SEGMENT NOMENCLATURE

DC Voltage Measurement

Autozero

Only those portions of the analog section which are used during DC voltage measurements are shown in Figure 3. As shown in the timing diagram (Figure 1), each measurement starts with an autozero (AZ) phase. During this phase, the integrator and comparator are configured as unity gain buffers and their non-

inverting inputs are connected to Common. The output of the integrator, which is equal to its offset, is stored on C_{AZ} - the autozero capacitor. Similarly, the offset of the comparator is stored in C_{INT}. The autozero cycle equals 1000 clock cycles which is one 60Hz line cycle with a 120kHz oscillator, or one 50Hz line cycle with a 100kHz oscillator.

Range 1 Integrate

The ICL7149 performs a full autorange search for each reading, beginning with range 1. During the range 1 integrate period, internal switches connect the INT V/Ω terminal to the Triple Point (Pin 20). The input signal is integrated for 10 clock cycles, which are gated out over a period of 1000 clock cycles to ensure good normal mode rejection of AC line interference.

Range 1 Deintegrate

At the beginning of the deintegrate cycle, the polarity of the voltage on the integrator capacitor (C_{INT}) is checked, and either the DEINT+ or DEINT- is asserted. The integrator capacitor C_{INT} is then discharged with a current equal to V_{REF}/R_{DEINT}. The comparator monitors the voltage on C_{INT}. When the voltage on C_{INT} is reduced to zero (actually to the V_{OS} of the comparator), the comparator output switches, and the current count is latched. If the C_{INT} voltage zero-crossing does not occur before 4000 counts have elapsed, the overload flag is set. "OL" (overload) is then displayed on the LCD. If the latched result is between 360 and 3999, the count is transferred to the output latches and is displayed. When the count is less than 360, an underrange has occurred, and the ICL7149 then switches to range 2 - the 40V scale.

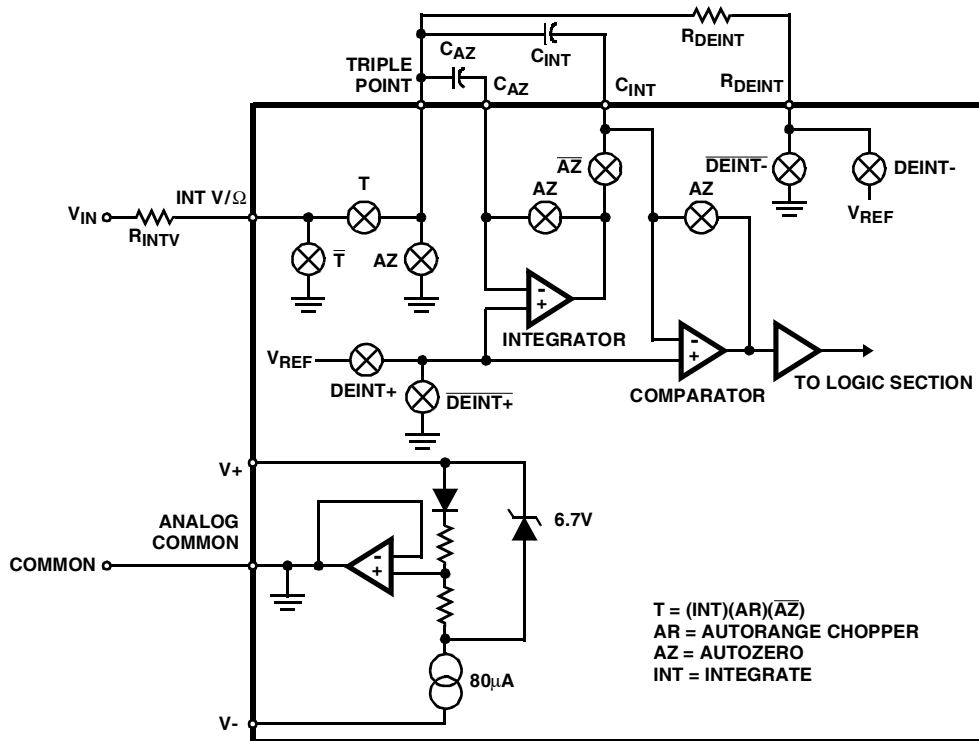

FIGURE 3. DETAILED CIRCUIT DIAGRAM FOR DC VOLTAGE MEASUREMENT

Range 2

The range 2 measurement begins with an autozero cycle similar to the one that preceded range 1 integration. Range 2 cycle length however, is one AC line cycle, minus 360 clock cycles. When performing the range 2 cycle, the signal is integrated for 100 clock cycles, distributed throughout one line cycle. This is done to maintain good normal mode rejection. Range 2 sensitivity is ten times greater than range 1 (100 vs 10 clock cycle integration) and the full scale voltage of range 2 is 40V. The range 2 deintegrate cycle is identical to the range 1 deintegrate cycle, with the result being displayed only for readings greater than 360 counts. If the reading is below 360 counts, the ICL7149 again asserts the internal underrange signal and proceeds to range 3.

Range 3

The range 3V or 4V full scale measurement is identical to the range 2 measurement, except that the input signal is integrated during the full 1000 clock cycles (one line frequency cycle). The result is displayed if the reading is greater than 360 counts. Underrange is asserted, and a range 4 measurement is performed if the result is below 360 counts.

Range 4

This measurement is similar to the range 1, 2 and 3 measurements, except that the integration period is 10,000 clock cycles (10 line cycles) long. The result of this measurement is transferred to the output latches and displayed even if the reading is less than 360.

Autozero

After finding the first range for which the reading is above 360 counts, the display is updated and an autozero cycle is entered. The length of the autozero cycle is variable which

results in a fixed measurement period of 24,000 clock cycles (24 line cycles).

DC Current

Figure 4 shows a simplified block diagram of the analog section of the ICL7149 during DC current measurement. The DC current measurements are very similar to DC voltage measurements except: 1) The input voltage is developed by passing the input current through a 0.1Ω (HI current ranges), or 9.9Ω (LOW current ranges) current sensing resistor; 2) Only those ranges with 1000 and 10,000 clock cycles of integration are used; 3) The R_{INT I} resistor is 1MΩ, rather than the 10MΩ value used for the R_{INT V} resistor.

By using the lower value integration resistor, and only the 2 most sensitive ranges, the voltage drop across the current sensing resistor is 40mV maximum on the 4mA and 400mA ranges; 400mV maximum on the 40mA and 4A scales. With some increase in noise, these “burden” voltages can be reduced by lowering the value of both the current sense resistors and the R_{INT I} resistor proportionally. The DC current measurement timing diagram is similar to the DC voltage measurement timing diagram, except in the DC current timing diagram, the first and second integrate and deintegrate phases are skipped.

AC Voltage Measurement

The ICL7149 is designed to be used with an optional AC to DC voltage converter circuit. It will autorange through two voltage ranges (400V and 40V), and the AC annunciator is enabled. A typical averaging AC to DC converter is shown in Figure 5, while an RMS to DC converter is shown in Figure 6. AC current can also be measured with some simple modifications to either of the two circuits in Figures 5 and 6.

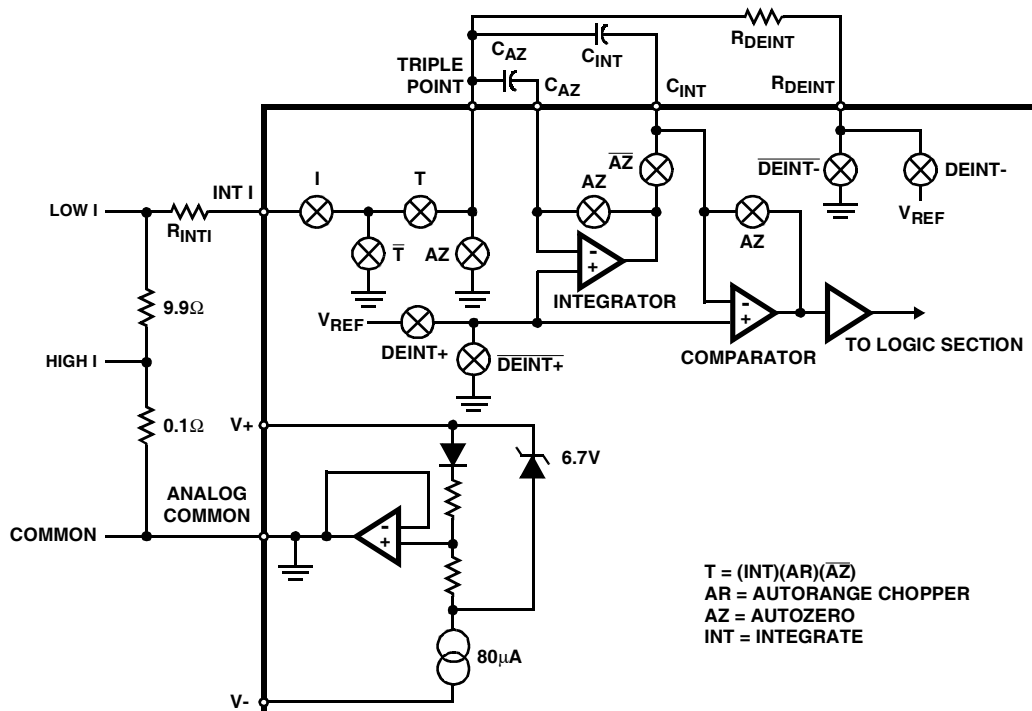

FIGURE 4. DETAILED CIRCUIT DIAGRAM FOR DC CURRENT MEASUREMENT

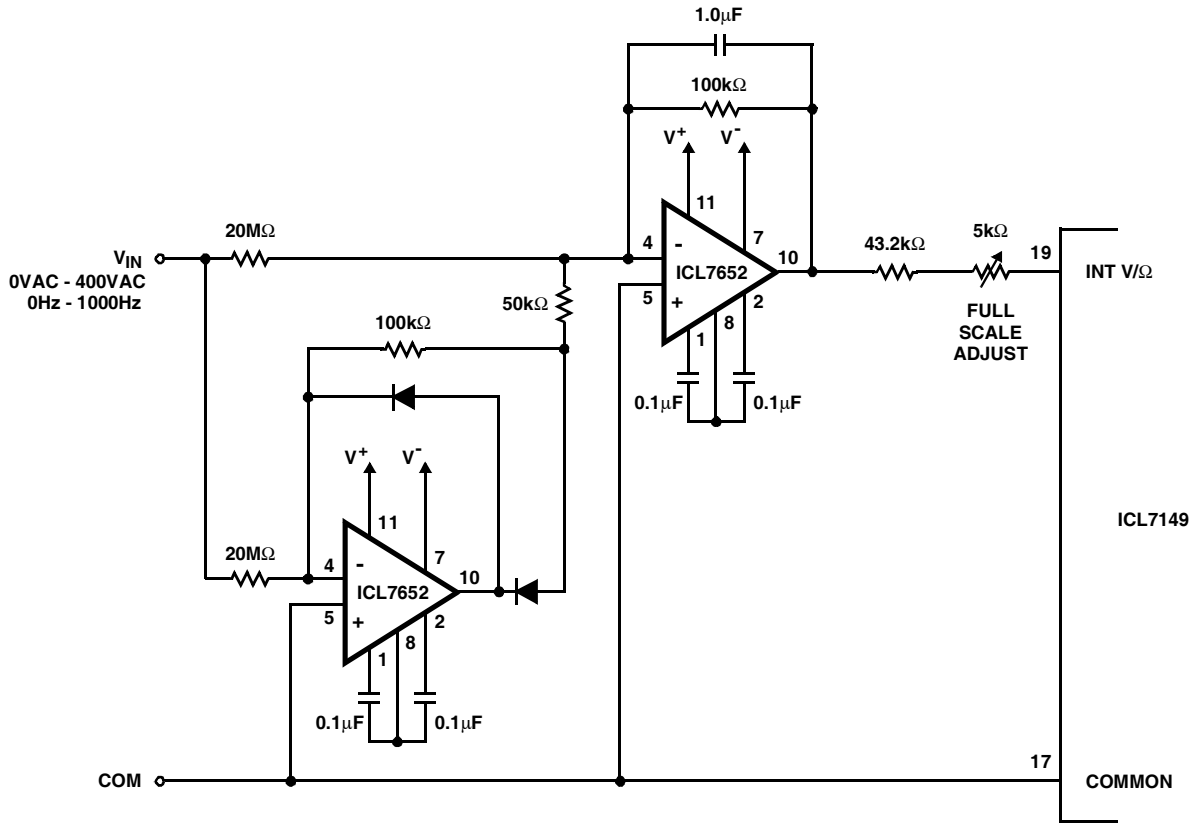

FIGURE 5. AC VOLTAGE MEASUREMENT USING OPTIONAL AVERAGING CIRCUIT

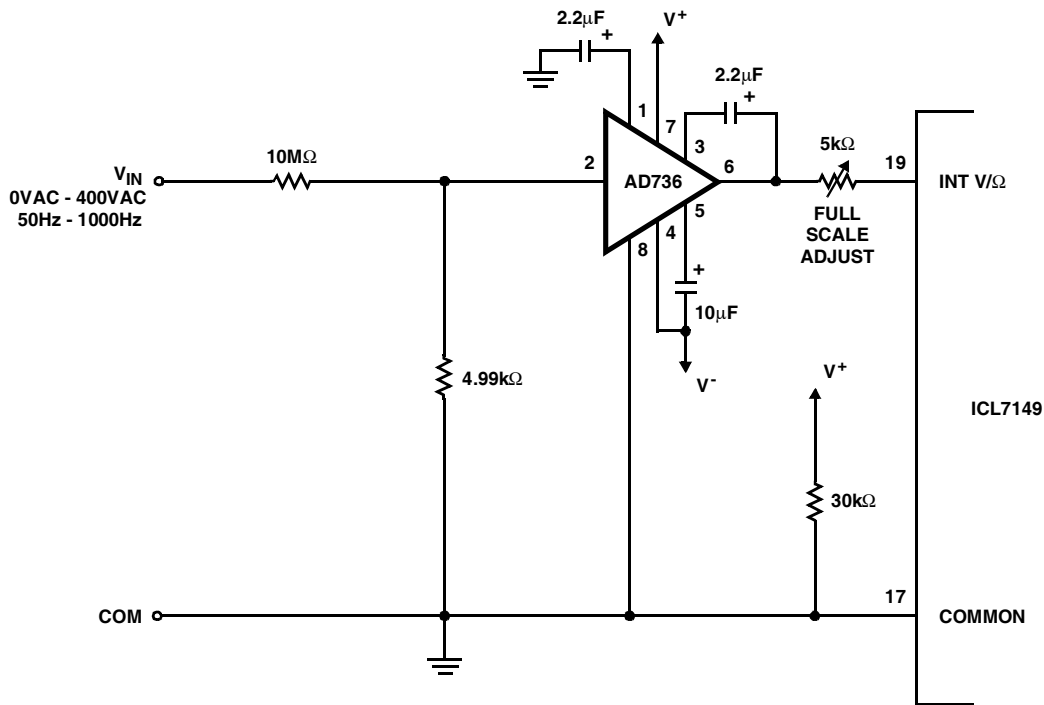

FIGURE 6. AC VOLTAGE MEASUREMENT USING OPTIONAL RMS CONVERTER CIRCUIT

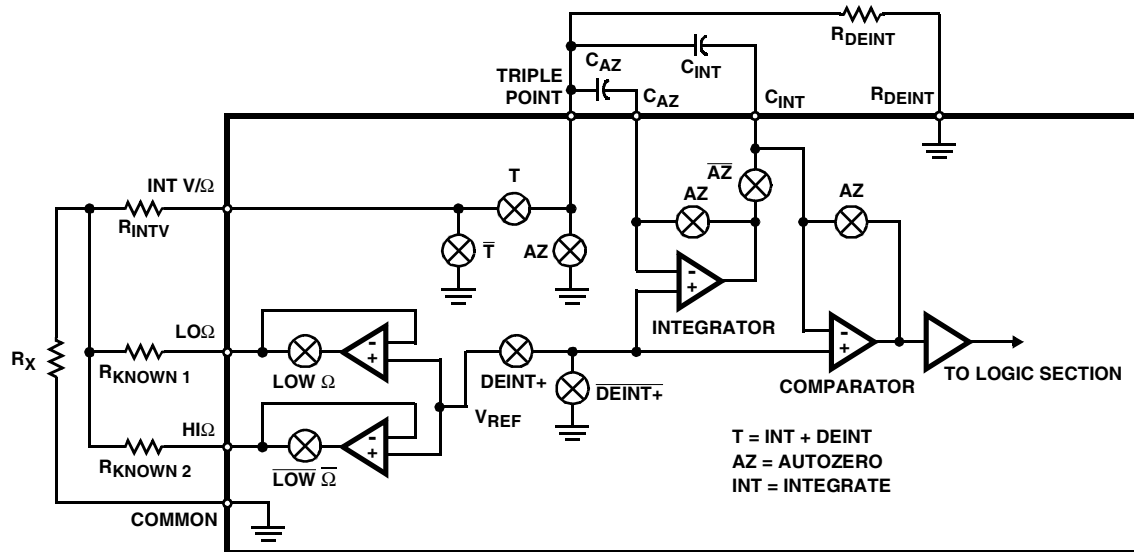

FIGURE 7. DETAILED CIRCUIT DIAGRAM FOR RATIOMETRIC Ω MEASUREMENT

Ratiometric Ω Measurement

The ratiometric Ω measurement is performed by first integrating the voltage across an unknown resistor, R_X , then effectively deintegrating the voltage across a known resistor (R_{KNOWN1} or R_{KNOWN2} of Figure 7). The shunting effect of R_{INTV} does not affect the reading because it cancels exactly between integration and deintegration. Like the current measurements, the Ω measurements are split into two sets of ranges. LO Ω measurements use a 10kΩ reference resistor, and the full scale ranges are 4kΩ and 40kΩ. HI Ω measurements use a 1MΩ reference resistor, and the full scale ranges are 0.4MΩ and 4MΩ. The measurement phases and timing are the same as the measurement phases and timing for DC current except: 1) During the integrate phases the input voltage is the voltage across the unknown resistor R_X , and; 2) During the deintegrate phases, the input voltage is the voltage across the reference resistor R_{KNOWN1} or R_{KNOWN2} .

Continuity Indication

When the ICL7149 is in the LO Ω measurement mode, the continuity circuit of Figure 8 will be active. When the voltage across R_X is less than approximately 100mV, the beeper output will be on. When R_{KNOWN} is 10kΩ, the beeper output will be on when R_X is less than 1kΩ.

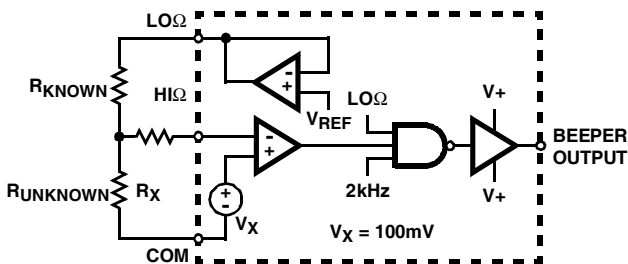

FIGURE 8. CONTINUITY BEEPER DRIVE CIRCUIT

Common Voltage

The analog and digital common voltages of the ICL7149 are generated by an on-chip resistor/zener/diode combination, shown in Figure 9. The resistor values are chosen so the coefficient of the diode voltage cancels the positive temperature coefficient of the zener voltage. This voltage is then buffered to provide the analog common and the digital common voltages. The nominal voltage between $V+$ and analog common is 3V. The analog common buffer can sink about 20mA, or source 0.01mA, with an output impedance of 10Ω. A pullup resistor to $V+$ may be used if more sourcing capability is desired. Analog common may be used to generate the reference voltage, if desired.

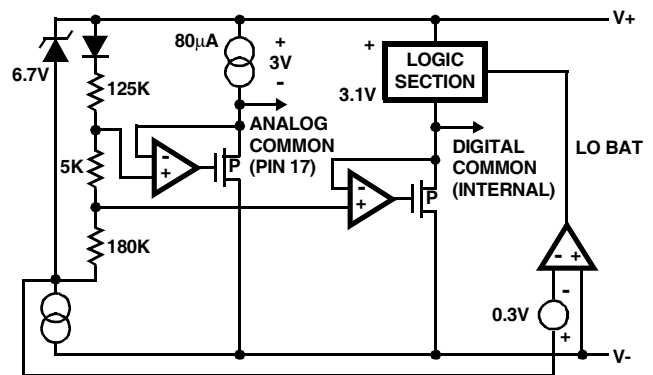

FIGURE 9. ANALOG AND DIGITAL COMMON VOLTAGE GENERATOR CIRCUIT

Oscillator

The ICL7149 uses a parallel resonant-type crystal in a Pierce oscillator configuration, as shown in Figure 10, and requires no other external components. The crystal eliminates the need to trim the oscillator frequency. An external signal may be capacitively coupled in OSC IN, with a signal level between 0.5V and 3V_{p-p}. Because the OSC

OUT pin is not designed to drive large external loads, loading on this pin should not exceed a single CMOS input. The oscillator frequency is internally divided by two to generate the ICL7149 clock. The frequency should be 120kHz to reject 60Hz AC signals, and 100kHz to reject 50Hz signals.

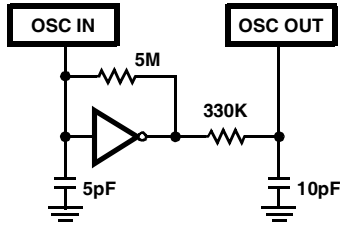

FIGURE 10. INTERNAL OSCILLATOR CIRCUIT DIAGRAM

Display Drivers

Figure 11 shows typical LCD Drive waveforms, RMS ON, and RMS OFF voltage calculations. Duplex multiplexing is used to minimize the number of connections between the ICL7149 and the LCD. The LCD has two separate back-planes. Each drive line can drive two individual segments, one referenced to each backplane. The ICL7149 drives 3³/₄ 7-segment digits, 3 decimal points, and 11 annunciators. Annunciators are used to indicate polarity, low battery condition, and the range in use. Peak drive voltage across the display is approximately 3V. An LCD with approximately 1.4V_{RMS} threshold voltage should be used. The third voltage level needed for duplex drive waveforms is generated through an on-chip resistor

string. The DC component of the drive waveforms is guaranteed to be less than 50mV.

Ternary Input

The Ω/Volts/Amps logic input is a ternary, or 3-level input. This input is internally tied to the common voltage through a high-value resistor, and will go to the middle, or “Volts” state, when not externally connected. When connected to V-, approximately 5μA of current flows out of the input. In this case, the logic level is the “Amps”, or low state. When connected to V+, about 5μA of current flows into the input. Here, the logic level is the “Ω”, or high state. For other pins, see Table 2.

TABLE 2. TERNARY INPUTS CONNECTIONS

PIN NUMBER	V+	OPEN OR COM	V-
25	mA	μA	Test
26	Ω	V	Amps
27	HiΩ/DC	LoΩ/AC	Test
28	Hold	Auto	Test

Component Selection

For optimum performance while maintaining the low-cost advantages of the ICL7149, care must be taken when selecting external components. This section reviews specifications and performance effects of various external components.

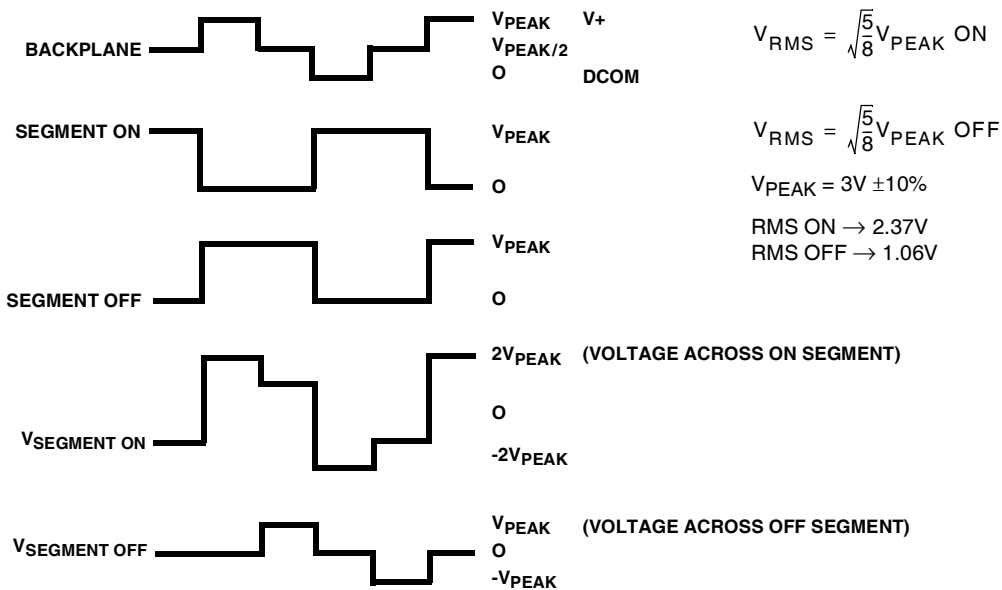

FIGURE 11. DUPLEXED LCD DRIVE WAVEFORMS

Integrator Capacitor, C_{INT}

As with all dual-slope integrating convertors, the integration capacitor must have low dielectric absorption to reduce linearity errors. Polypropylene capacitors add undetectable errors at a reasonable cost, while polystyrene and polycarbonate may be used in less critical applications. The ICL7149 is designed to use a 3.3nF (0.0033μF) C_{INT} with an oscillator frequency of 120kHz and an R_{INTV} of 10MΩ. With a 100kHz oscillator frequency (for 50Hz line frequency rejection), C_{INT} and R_{INTV} affects the voltage swing of the integrator. Voltage swing should be as high as possible without saturating the integrator. Saturation occurs when the integrator output is within 1V of either $V+$ or $V-$. Integrator voltage swing should be about ±2V when using standard component values. For different R_{INTV} and oscillator frequencies the value of C_{INT} can be calculated from:

$$C_{INT} = \frac{(\text{Integrate Time}) \times (\text{Integrate Current})}{(\text{Desired Integrator Swing})}$$

$$= \frac{(10,000 \times 2 \times \text{Oscillator Period}) \times 0.4V/R_{INTV}}{(2V)}$$

Integrator Resistors

The normal values of the R_{INTV} and R_{INTI} resistors are 10MΩ and 1MΩ respectively. Though their absolute values are not critical, unless the value of the current sensing resistors are trimmed, their ratio should be 10:1, within 0.05%. Some carbon composition resistors have a large voltage coefficient which will cause linearity errors on the 400V scale. Also, some carbon composition resistors are very noisy. The class “A” output of the integrator begins to have nonlinearities if required to sink more than 70μA (the sourcing limit is much higher). Because R_{INTV} drives a virtual ground point, the input impedance of the meter is equal to R_{INTV} .

Deintegration Resistor, R_{DEINT}

Unlike most dual-slope A/D converters, the ICL7149 uses different resistors for integration and deintegration. R_{DEINT} should normally be the same value as R_{INTV} , and have the same temperature coefficient. Slight errors in matching may be corrected by trimming the reference voltage.

Autozero Capacitor, C_{AZ}

The C_{AZ} is charged to the integrator’s offset voltage during the autozero phases, and subtracts that voltage from the input signal during the integrate phases. The integrator thus appears to have zero offset voltage. Minimum C_{AZ} value is determined by: 1) Circuit leakages; 2) C_{AZ} self-discharge; 3) Charge injection from the internal autozero switches. To avoid errors, the C_{AZ} voltage change should be less than 1/10 of a count during the 10,000 count clock cycle integration period for the 400mV range. These requirements set a lower limit of 0.047μF for C_{AZ} but 0.1μF is the preferred value. The upper limit on the value of C_{AZ} is set by the time constant of the autozero loop, and the 1 line cycle time period allotted to autozero. C_{AZ} may be several 10s of μF before approaching this limit.

The ideal C_{AZ} is a low leakage polypropylene or Teflon capacitor. Other film capacitors such as polyester, polystyrene, and polycarbonate introduce negligible errors. If a few seconds of settling time upon power-up is acceptable, the C_{AZ} may be a ceramic capacitor, provided it does not have excessive leakage.

Ohm Measurement Resistors

Because the ICL7149 uses a ratiometric ohm measurement technique, the accuracy of ohm reading is primarily determined by the absolute accuracy of the R_{KNOWN1} and R_{KNOWN2} . These should normally be 10kΩ and 1MΩ, with an absolute accuracy of at least 0.5%.

Current Sensing Resistors

The 0.1Ω and 9.9Ω current sensing resistors convert the measured current to a voltage, which is then measured using R_{INTI} . The two resistors must be closely matched, and the ratio between R_{INTI} and these two resistors must be accurate - normally 0.5%. The 0.1Ω resistor must be capable of handling the full scale current of 4A, which requires it to dissipate 1.6W.

Continuity Beeper

The Continuity Beeper output is designed to drive a piezoelectric transducer at 2kHz (using a 120kHz crystal), with a voltage output swing of $V+$ to $V-$. The beeper output off state is at the $V+$ rail. When crystals with different frequencies are used, the frequency needed to drive the transducer can be calculated by dividing the crystal frequency by 60.

Display

The ICL7149 uses a custom, duplexed drive display with range, polarity, and low battery annunciators. With a 3V peak display voltage, the RMS ON voltage will be 2.37V minimum; RMS OFF voltage will be 1.06V maximum. Because the display voltage is not adjustable, the display should have a 10% ON threshold of about 1.4V. Most display manufacturers supply a graph that shows contrast versus RMS drive voltage. This graph can be used to determine what the contrast ratio will be when driven by the ICL7149. Most display thresholds decrease with increasing temperature. The threshold at the maximum operating temperature should be checked to ensure that the “off” segments will not be turned “on” at high temperatures.

Crystal

The ICL7149 is designed to use a parallel resonant 120kHz or 100kHz crystal with no additional external components. The R_S parameter should be less than 25kΩ to ensure oscillation. Initial frequency tolerance of the crystal can be a relatively loose 0.05%.

Switches

Because the logic input draws only about 5μA, switches driving these inputs should be rated for low current, or “dry” operations. The switches on the external inputs must be able

to reliably switch low currents, and be able to handle voltages in excess of 400V_{AC}.

Reference Voltage Source

A voltage divider connected to V+ and Common is the simplest source of reference voltage. While minimizing external component count, this approach will provide the same voltage tempco as the ICL7149 Common - about 100PPM/°C. To improve the tempco, an ICL8069 bandgap reference may be used (see Figure 12). The reference voltage source output impedance must be $\leq R_{DEINT}/4000$.

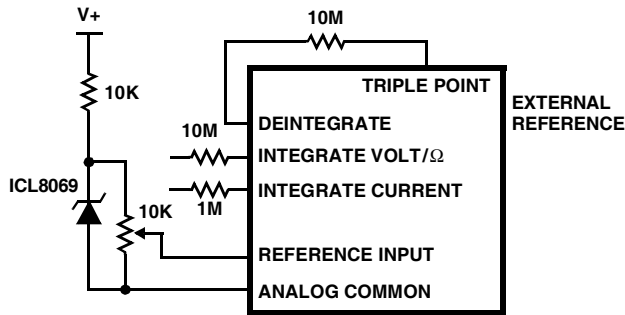

FIGURE 12. EXTERNAL VOLTAGE REFERENCE CONNECTION

Applications, Examples, and Hints

A complete autoranging 3³/₄ digit multimeter is shown in Figure 13. The following sections discuss the functions of specific components and various options.

Meter Protection

The ICL7149 and its external circuitry should be protected against accidental application of 110/220V AC line voltages on the Ω and current ranges. Without the necessary precautions, the ICL7149 and its external components could be damaged under such fault conditions. For the current ranges, fast-blow fuses should be used between S5A in Figure 13 and the 0.1Ω and 9.9Ω shunt resistors. For the Ω ranges, no additional protection circuitry is required. However, the 10kΩ resistor connected to pin 14 must be able to dissipate 1.2W or 4.8W for short periods of time during accidental application of 110V or 220V_{AC} line voltages respectively.

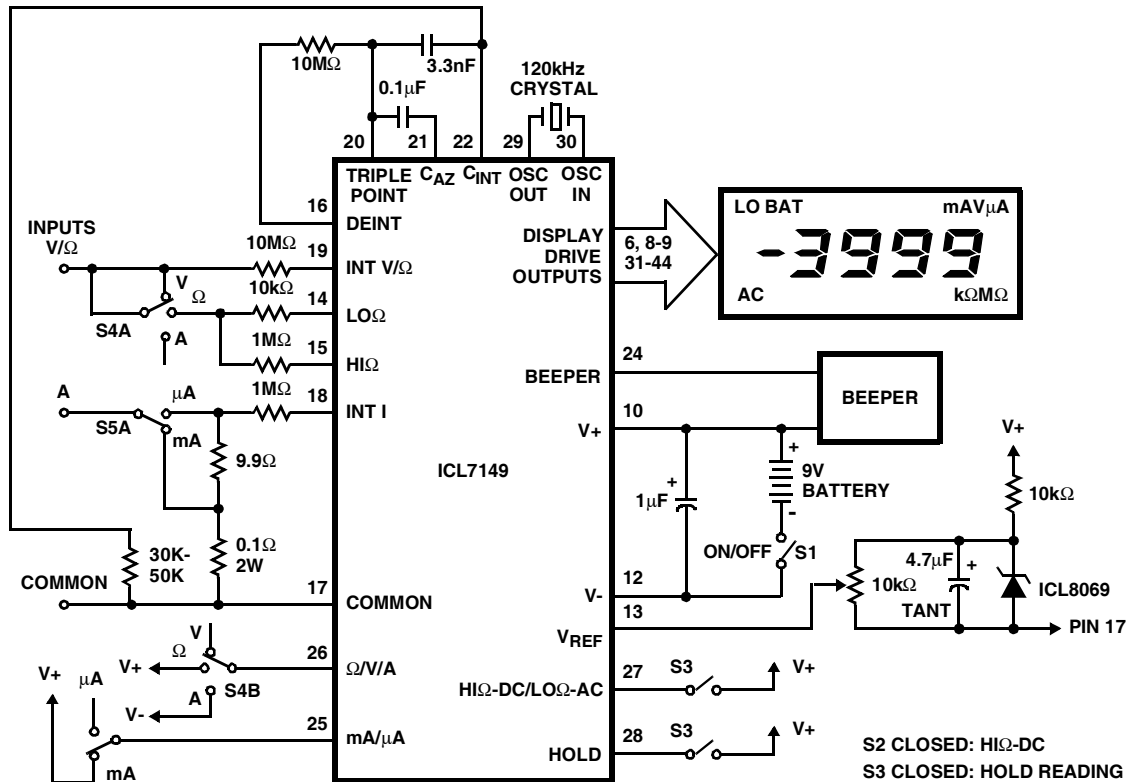

NOTES:

1. Crystal is a Statek or SaRonix CX-IV type.
2. Multimeter protection components have not been shown.
3. Display is from LXD, part number 38D8R02H (or Equivalent).
4. Beeper is from muRata, part number PKM24-4A0 (or Equivalent).

FIGURE 13. BASIC MULTIMETER APPLICATION CIRCUIT

Printed Circuit Board Layout Considerations

Particular attention must be paid to rollover performance, leakages, and guarding when designing the PCB for an ICL7149-based multimeter.

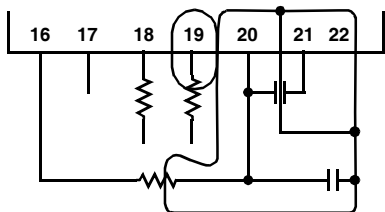

FIGURE 14. PC BOARD LAYOUT

Rollover Performance, Leakages, and Guarding

Because the ICL7149 system measures very low currents, it is essential that the PCB have low leakage. Boards should be properly cleaned after soldering. Areas of particular importance are: 1) The INT V/Ω and INT I Pins; 2) The Triple Point; 3) The R_{DEINT} and the C_{AZ} pins.

The conversion scheme used by the ICL7149 changes the common mode voltage on the integrator and the capacitors C_{AZ} and C_{INT} during a positive deintegrate cycle. Stray capacitance to ground is charged when this occurs, removing some of the charge on C_{INT} and causing rollover error. Rollover error increases about 1 count for each picofarad of capacitance between C_{AZ} or the Triple Point and ground, and is seen as a zero offset for positive voltages. Rollover error is not seen as gain error.

The rollover error causes the width of the +0 count to be larger than normal. The ICL7149 will thus read zero until several hundred microvolts are applied in the positive direction. The ICL7149 will read -1 when approximately -100μV is applied.

The rollover error can be minimized by guarding the Triple Point and C_{AZ} nodes with a trace connected to the C_{INT} pin, (see Figure 14) which is driven by the output of the integrator. Guarding these nodes with the output of the integrator reduces the stray capacitance to ground, which

minimizes the charge error on C_{INT} and C_{AZ} . If possible, the guarding should be used on both sides of the PC board.

Stray Pickup

While the ICL7149 has excellent rejection of line frequency noise and pickup in the DC ranges, any stray coupling will affect the AC reading. Generally, the analog circuitry should be as close as possible to the ICL7149. The analog circuitry should be removed or shielded from any 120V AC power inputs, and any AC sources such as LCD drive waveforms. Keeping the analog circuit section close to the ICL7149 will also help keep the area free of any loops, thus reducing magnetically coupled interference coming from power transformers, or other sources.

Metric Plastic Quad Flatpack Packages (MQFP)

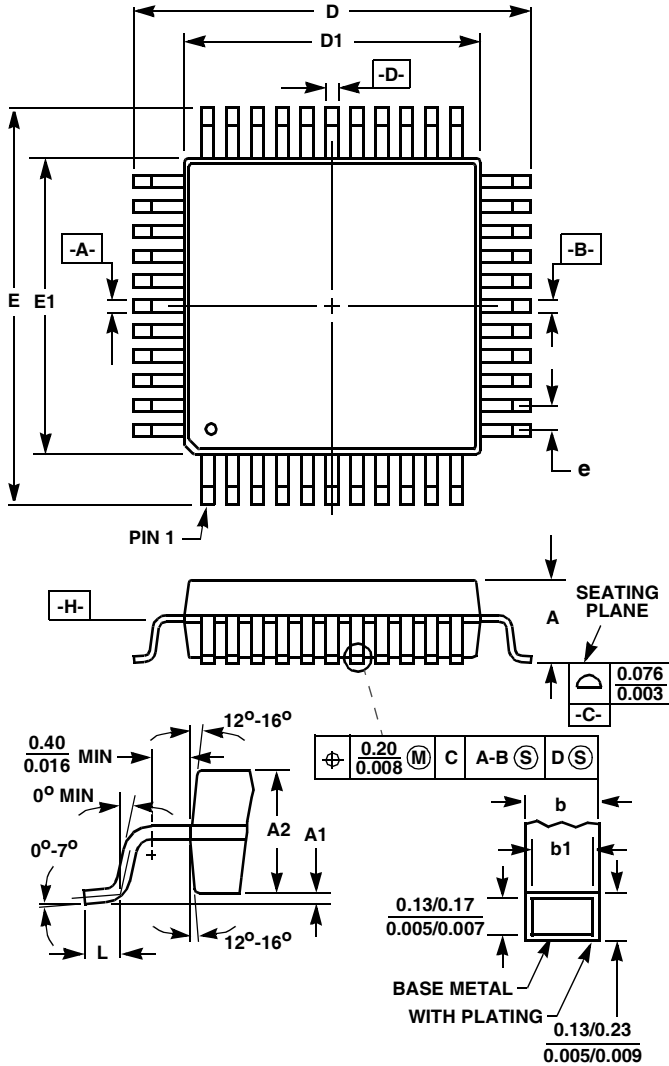

**Q44.10x10 (JEDEC MS-022AB ISSUE B)
44 LEAD METRIC PLASTIC QUAD FLATPACK PACKAGE**

SYMBOL	INCHES		MILLIMETERS		NOTES
	MIN	MAX	MIN	MAX	
A	-	0.096	-	2.45	-
A1	0.004	0.010	0.10	0.25	-
A2	0.077	0.083	1.95	2.10	-
b	0.012	0.018	0.30	0.45	6
b1	0.012	0.016	0.30	0.40	-
D	0.515	0.524	13.08	13.32	3
D1	0.389	0.399	9.88	10.12	4, 5
E	0.516	0.523	13.10	13.30	3
E1	0.390	0.398	9.90	10.10	4, 5
L	0.029	0.040	0.73	1.03	-
N	44		44		7
e	0.032 BSC		0.80 BSC		-

Rev. 2 4/99

NOTES:

- Controlling dimension: MILLIMETER. Converted inch dimensions are not necessarily exact.
- All dimensions and tolerances per ANSI Y14.5M-1982.
- Dimensions D and E to be determined at seating plane -C-.
- Dimensions D1 and E1 to be determined at datum plane -H-.
- Dimensions D1 and E1 do not include mold protrusion. Allowable protrusion is 0.25mm (0.010 inch) per side.
- Dimension b does not include dambar protrusion. Allowable dambar protrusion shall be 0.08mm (0.003 inch) total.
- "N" is the number of terminal positions.