

THIS DRAWING IS UNPUBLISHED. RELEASED FOR PUBLICATION
 © COPYRIGHT 2011 BY TYCO ELECTRONICS CORPORATION. ALL RIGHTS RESERVED.

LOC DW	DIST	REVISIONS			
P	LTR	DESCRIPTION	DATE	DWN	APVD
C		REVISED (ECR-13-012457)	14AUG13	JL	WK

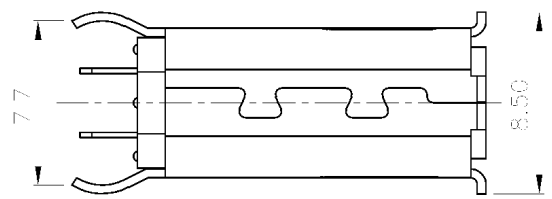
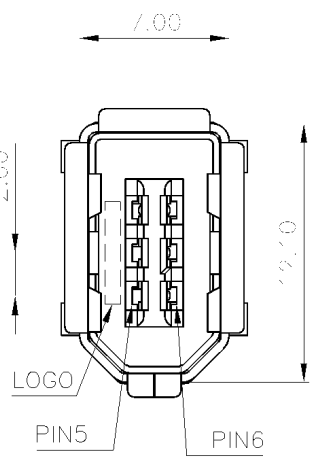
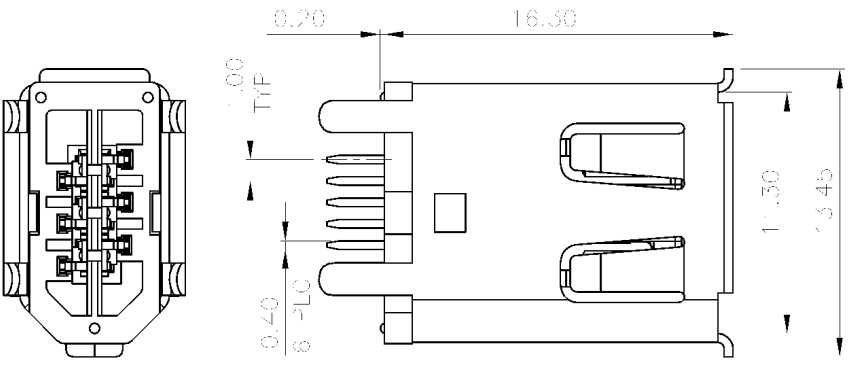
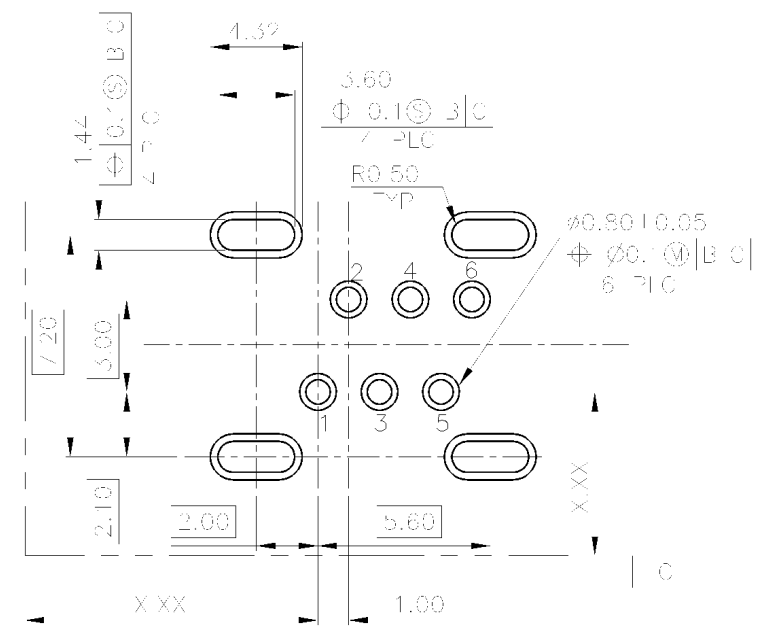
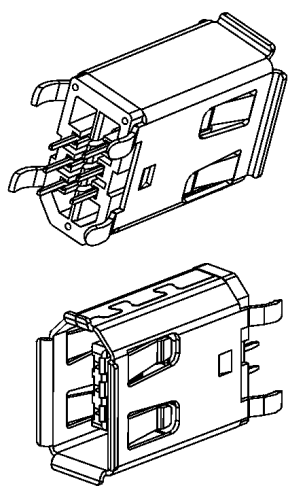
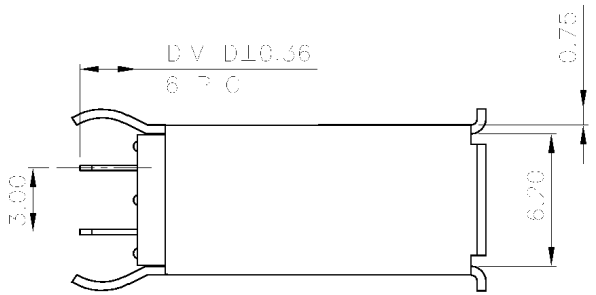

RECOMMENDED PCB LAYOUT

NOTE:
 1. MATERIAL:
 HOUSING: THERMOPLASTIC HIGH TEMP., UL 94V-0, BLACK COLOR.
 CONTACT: BRASS, THICKNESS=0.25mm.
 SHELL: PHOSPHOR BRONZE, THICKNESS=0.40mm
 2. FINISH:
 CONTACT: 0.762µm [30µ"] MIN. GOLD PLATED ON CONTACT AREA,
 2.54µm [100µ"] MIN. TIN-Cu PLATED ON SOLDER TAILS,
 1.27µm [50µ"] MIN. NICKEL UNDERPLATED ALL OVER.
 SHELL: 3.048µm [120µ"] MIN. NICKEL PLATED ALL OVER
 2.54µm [100µ"] MIN. Cu UNDERPLATED ALL OVER
 3. REFLOW SOLDER CAPABLE TO 260°C PER TEST SPEC.
 109-201, CONDITION B.

3.18	1734290-2
2.69	1734290-1
DIM D	PART NUMBER

THIS DRAWING IS A CONTROLLED DOCUMENT.		DWN O. HU	23DEC2005	TE Connectivity	
DIMENSIONS: mm		CHK S. HOU	23DEC2005		
TOLERANCES UNLESS OTHERWISE SPECIFIED:		APVD W.J. KE	23DEC2005	NAME	
0 PLC ± 0.38 1 PLC ± 0.25 2 PLC ± 0.13 3 PLC ± 0.05 4 PLC ± 0.05 ANGLES ± ± 3°		PRODUCT SPEC 108-57599		IEEE 1394, RCPT, 6P VERTICAL, T/H	
MATERIAL SEE NOTE		APPLICATION SPEC		SIZE A3	CAGE CODE 00779
FINISH SEE NOTE		WEIGHT 2.62 GRAMS		DRAWING NO C=1734290	
		CUSTOMER DRAWING		RESTRICTED TO	
		SCALE		SHEET 1 of 2	REV C

THIS DRAWING IS UNPUBLISHED. RELEASED FOR PUBLICATION
 © COPYRIGHT 2011 BY TYCO ELECTRONICS CORPORATION. ALL RIGHTS RESERVED.

LOC DW	DIST	REVISIONS			
P	LTR	DESCRIPTION	DATE	DWN	APVD
		SEE SHEET 1.			

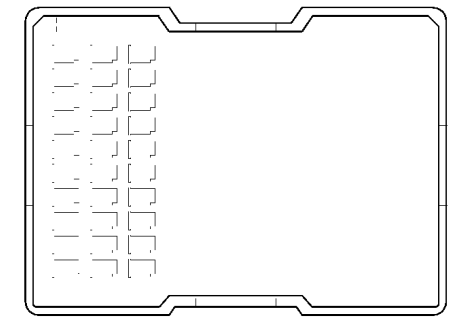
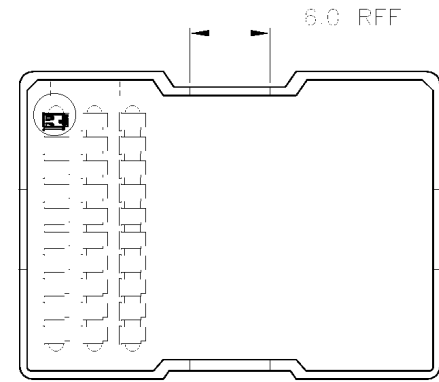
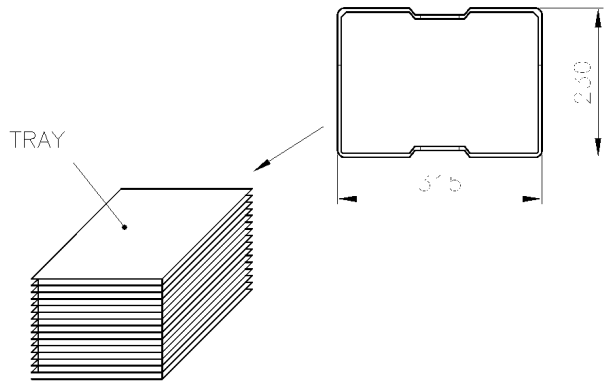

- NOTES:
- MATERIAL:
TRAY: PET
SHIPPING BOX: CORRUGATED FIBER.
 - DIMENSION:
TRAY: L=315mm, W=230mm, H=11.3mm
SHIPPING BOX: 509mm*345mm*248mm
 - QUANTITY: SEE TABLE.
 - WEIGHT: SEE TABLE.

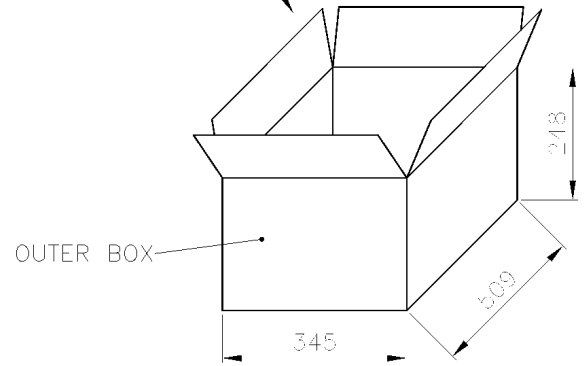
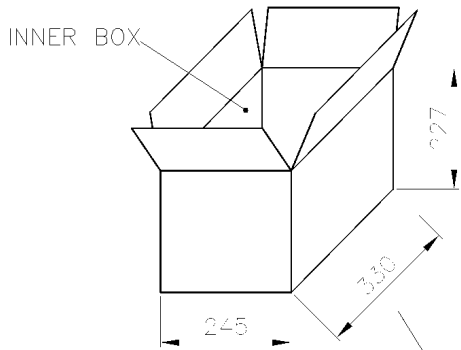

15.0	14.0	4000	2	20	100
N.W(KGS)	N.W(KGS)	PACKAGING QTY'S/ OUTER BOX	INNER BOX/ OUTER BOX	TRAYS/ INNER BOX	PCS/ TRAY

THIS DRAWING IS A CONTROLLED DOCUMENT.		DWN	 TE Connectivity					
DIMENSIONS: mm		CHK				NAME		
TOLERANCES UNLESS OTHERWISE SPECIFIED:		APVD				IEEE 1394, RCPT, 6P VERTICAL, T/H		
0 PLC ± - 1 PLC ± - 2 PLC ± - 3 PLC ± - 4 PLC ± - ANGLES ± -		PRODUCT SPEC				SIZE CAGE CODE DRAWING NO RESTRICTED TO		
MATERIAL		APPLICATION SPEC	A3 00779 C=1734290		-			
FINISH		WEIGHT	CUSTOMER DRAWING		SCALE SHEET 2 of 2 REV C			