

# AS3661

## Programmable 9-channel LED Driver

### 1 General Description

The AS3661 is a 9-channel LED driver designed to produce lighting effects for mobile devices. A high-efficiency charge pump enables LED driving over full Li-Ion battery voltage range. The device is equipped with an internal program memory, which allows operation without processor control. The AS3661 maintains excellent efficiency over a wide operating range by autonomously selecting the best charge pump gain based on LED forward voltage requirements. AS3661 is able to automatically enter power-save mode when LED outputs are not active, thus lowering idle current consumption down to 10  $\mu$ A (typ).

The AS3661 has an I2C-compatible control interface with four pin selectable addresses. Also, the device has a flexible General Purpose Output (GPO), which can be used as a digital control pin for other devices. INT pin can be used to notify processor when a lighting sequence has ended (interrupt - function). Also, the device has a trigger input interface, which allows synchronization between multiple devices. The device requires only four small and low-cost ceramic capacitors.

The AS3661 is available in a tiny WL-CSP-25 (2.285x2.285mm) 0.4mm pitch package.

### 2 Key Features

- Three independent program execution engines; 9 programmable outputs with 25.5 mA full-scale current, 8-bit current setting resolution and 12-bit PWM control resolution
- Adaptive charge pump with 1x and 1.5x gain provides up to 95% LED drive efficiency
- Charge pump with soft start and overcurrent/short circuit protection
- Built-in LED test
- Automatic power save mode; IVDD = 10  $\mu$ A (typ.)
- Two wire, I2C-compatible, control interface
- Flexible instruction set
- Large SRAM program memory
- Small application circuit
- Source (high side) drivers
- Minimum number of external components
- Architecture supports color control

### 3 Applications

The product is ideal for fun and indicator lights, LED backlighting, and programmable current source.

Figure 1. AS3661 LED Driver Block Diagram

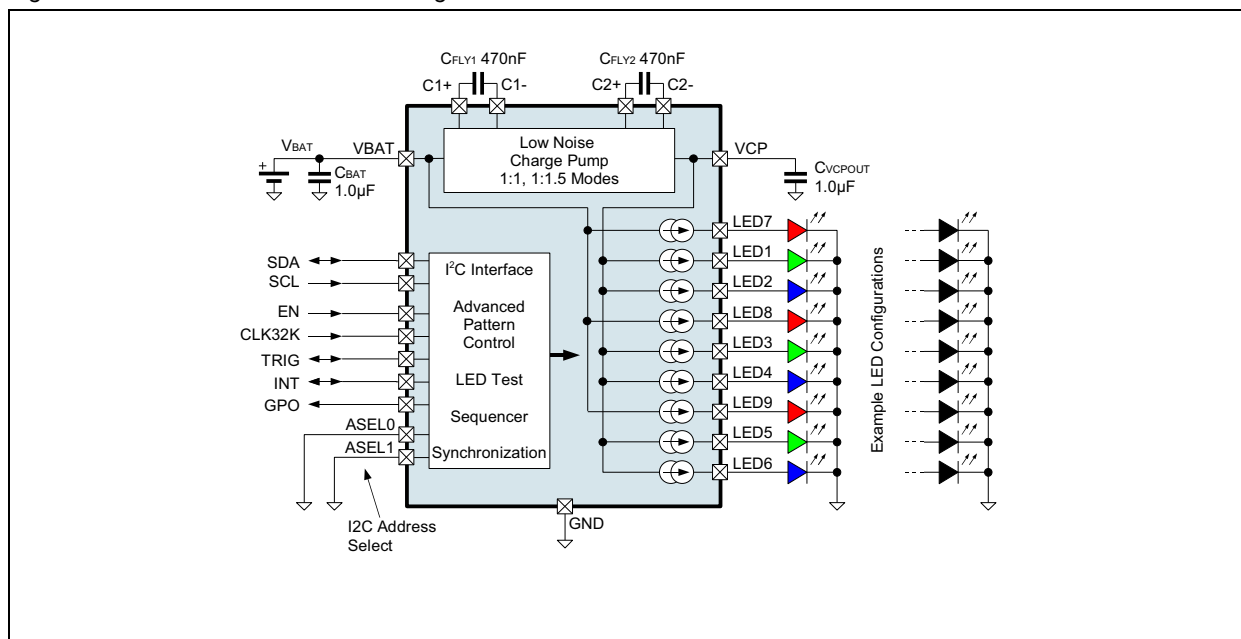

## Contents

<b>1 General Description</b>	<b>1</b>
<b>2 Key Features</b>	<b>1</b>
<b>3 Applications</b>	<b>1</b>
<b>4 Pinout</b>	<b>5</b>
4.1 Pin Assignment	5
4.2 Pin Description	5
<b>5 Absolute Maximum Ratings</b>	<b>7</b>
<b>6 Electrical Characteristics</b>	<b>8</b>
<b>7 Typical Operating Characteristics</b>	<b>12</b>
<b>8 Detailed Description</b>	<b>14</b>
8.1 Programming	14
8.2 LED Error Detection	14
8.3 Energy Efficiency	14
8.4 Temperature Compensation	14
8.5 Modes of Operation	16
8.5.1 RESET	16
8.5.2 STANDBY	16
8.5.3 STARTUP	16
8.5.4 NORMAL	16
8.5.5 POWER SAVE	16
8.6 Charge Pump Operational Description	17
8.6.1 Overview	17
8.6.2 Output Resistance	17
8.6.3 Controlling the Charge Pump	18
8.6.4 LED Forward Voltage Monitoring	18
8.6.5 Gain Change Hysteresis	18
8.6.6 Automatic Power Save Mode	19
8.6.7 PWM Power Save Mode	19
8.7 LED Driver Operational Description	20
8.7.1 Powering LEDs	21
8.7.2 Controlling the High-side LED Drivers	21
8.8 I2C Compatible Control Interface	22
8.8.1 I <sup>2</sup> C Address selection	22
8.8.2 Bus Not Busy	22
8.8.3 Start Data Transfer	22
8.8.4 Stop Data Transfer	22
8.8.5 Data Valid	22
8.8.6 Acknowledge	22
8.8.7 Program Downloading	25
8.9 Register Set	25
8.10 Control Register Details	35
8.10.1 ENABLE/ ENGINE CONTROL1	35
8.10.2 ENGINE CNTRL2	36
8.10.3 OUTPUT DIRECT/RATIOMETRIC MSB and LSB	37
8.10.4 OUTPUT ON/OFF CONTROL MSB and LSB	38

8.10.5 LEDx Control .....	39
8.10.6 LEDx PWM .....	45
8.10.7 LEDx CURRENT CONTROL .....	48
8.10.8 MISC .....	51
8.10.9 ENGINEx PC .....	52
8.10.10 STATUS/INTERRUPT .....	52
8.10.11 GPO .....	54
8.10.12 VARIABLE .....	54
8.10.13 RESET .....	54
8.10.14 TEMP ADC CONTROL .....	55
8.10.15 TEMPERATURE READ .....	55
8.10.16 TEMPERATURE WRITE .....	56
8.10.17 LED TEST CONTROL .....	56
8.10.18 LED TEST ADC .....	57
8.10.19 ENGINE1 VARIABLE A .....	58
8.10.20 ENGINE2 VARIABLE A .....	58
8.10.21 ENGINE3 VARIABLE A .....	58
8.10.22 MASTER FADER1 .....	58
8.10.23 49 MASTER FADER2 .....	59
8.10.24 4A MASTER FADER3 .....	59
8.10.25 ENG1 PROG START ADDR .....	59
8.10.26 ENG2 PROG START ADDR .....	59
8.10.27 ENG3 PROG START ADDR .....	59
8.10.28 PROG MEM PAGE SELECT .....	60
8.10.29 ENG1 MAPPING MSB .....	60
8.10.30 71H ENG1 MAPPING LSB .....	60
8.10.31 ENG2 MAPPING MSB .....	61
8.10.32 ENG2 MAPPING LSB .....	61
8.10.33 ENG3 MAPPING MSB .....	61
8.10.34 ENG3 MAPPING LSB .....	62
8.10.35 GAIN CHANGE CTRL .....	63
<b>8.11 Instruction Set .....</b>	<b>64</b>
<b>8.12 LED Driver Instructions .....</b>	<b>67</b>
8.12.1 RAMP (Numerical Operands) .....	67
8.12.2 RAMP (Variables) .....	68
8.12.3 SET PWM (Numerical Operands) .....	69
8.12.4 SET PWM (Variables) .....	70
8.12.5 WAIT .....	70
<b>8.13 LED Mapping Instructions .....</b>	<b>71</b>
8.13.1 MUX_LD_START .....	71
8.13.2 MUX_LD_END .....	71
8.13.3 MUX_MAP_START .....	72
8.13.4 MUX_SEL .....	72
8.13.5 MUX_CLR .....	72
8.13.6 MUX_MAP_NEXT .....	73
8.13.7 MUX_MAP_PREV .....	73
8.13.8 MUX_LD_NEXT .....	74
8.13.9 MUX_LD_PREV .....	74
8.13.10 MUX_MAP_ADDR .....	74

8.13.11 MUX_LD_ADDR .....	74
<b>8.14 Branch Instructions .....</b>	<b>75</b>
8.14.1 RST .....	75
8.14.2 BRANCH (Numerical) .....	75
8.14.3 BRANCH (Variables) .....	76
8.14.4 INT .....	76
8.14.5 END .....	76
8.14.6 TRIGGER .....	76
8.14.7 JNE/JL/JGE/JE .....	77
<b>8.15 Arithmetic Instructions .....</b>	<b>78</b>
8.15.1 LD .....	78
8.15.2 ADD (Numerical Operands) .....	78
8.15.3 ADD (Variables) .....	78
8.15.4 SUB (Numerical) .....	79
8.15.5 SUB (Variables) .....	79
<b>9 Typical Application .....</b>	<b>81</b>
9.1 Recommended External Components .....	82
<b>10 Package Drawings and Markings .....</b>	<b>83</b>
<b>11 Ordering Information .....</b>	<b>84</b>

## 4 Pinout

### 4.1 Pin Assignment

Figure 2. Pin Assignments (Top View)

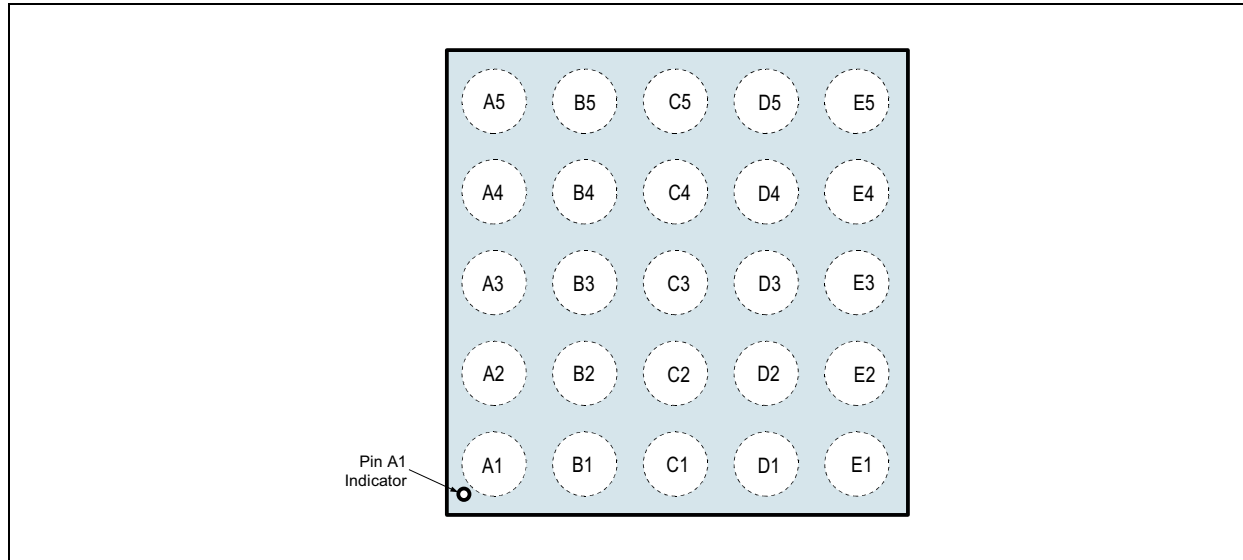

### 4.2 Pin Description

Table 1. Pin Description for AS3661

Pin Number	Pin Name	Description
A1	LED1	<b>LED1 Output.</b> Current source from VCP.
A2	LED2	<b>LED2 Output.</b> Current source from VCP.
A3	VCP	<b>Charge Pump output.</b> make a short connection to capacitor CVCPOUT.
A4	C2-	<b>Charge Pump flying capacitor 2.</b> make a short connection to capacitor CFLY2.
A5	C2+	<b>Charge Pump flying capacitor 2.</b> make a short connection to capacitor CFLY2.
B1	LED3	<b>LED3 Output.</b> Current source from VCP.
B2	LED4	<b>LED4 Output.</b> Current source from VCP.
B3	ASEL1	<b>Digital input - I<sup>2</sup>C address select</b>
B4	C1-	<b>Charge Pump flying capacitor 1.</b> make a short connection to capacitor CFLY1.
B5	C1+	<b>Charge Pump flying capacitor 1.</b> make a short connection to capacitor CFLY1.
C1	LED5	<b>LED5 Output.</b> Current source from VCP.
C2	LED6	<b>LED6 Output.</b> Current source from VCP.
C3	ASEL0	<b>Digital input - I<sup>2</sup>C address select</b>
C4	EN	<b>Enable.</b> Active high digital input.
C5	VBAT	<b>Positive Power Supply Input</b>
D1	LED7	<b>LED7 Output.</b> Current source from VBAT.
D2	LED8	<b>LED8 Output.</b> Current source from VBAT.
D3	INT	<b>Interrupt Output.</b> Open drain digital output for microcontroller unit, leave unconnected if not used.
D4	CLK32K	<b>Digital Clock Input.</b> Connect a 32kHz signal; if this signal is not available, connect this pin to GND.

Table 1. Pin Description for AS3661

Pin Number	Pin Name	Description
D5	GND	<b>Ground</b>
E1	LED9	<b>LED9 Output.</b> Current source from VBAT.
E2	GPO	<b>General Purpose Output.</b> Leave unconnected if not used.
E3	TRIG	<b>Trigger Input.</b> Open drain, connect to ground if not used.
E4	SDA	<b>Serial-Data I/O.</b> Open drain digital I/O I <sup>2</sup> C data pin.
E5	SCL	<b>Serial-Clock Input</b>

## 5 Absolute Maximum Ratings

Stresses beyond those listed in [Table 2](#) may cause permanent damage to the device. These are stress ratings only, and functional operation of the device at these or any other conditions beyond those indicated in [Table 3. Electrical Characteristics on page 8](#) is not implied. Exposure to absolute maximum rating conditions for extended periods may affect device reliability.

Table 2. Absolute Maximum Ratings

Parameter	Min	Max	Units	Comments
VBAT, VCP, C1+, C1-, C2+, C2- to GND	-0.3	+7.0	V	
VCP to VBAT	-0.3		V	Diode between VCP and VBAT
LED1, LED2...LED9 to GND	-0.3	+7.0	V	
SDA, SCL, EN, CLK32K, TRIG, INT, GPO, ASELO, ASEL1 to GND	-0.3	+7.0	V	
<b>Electrostatic Discharge</b>				
ESD HBM (LED1 to LED2)		8	kV	JEDEC JESD22-A114
ESD HBM (all other pins)		2.5	kV	
ESD MM		250	V	JEDEC JESD22-A115
ESD CDM		1	kV	JEDEC JESD22-C101
<b>Temperature Ranges and Storage Conditions</b>				
Continous Power Dissipation				Internally limited (overtemperature protection) <sup>1</sup>
Junction Temperature (T <sub>JMAX</sub> )		+125	°C	
Storage Temperature Range	-55	+125	°C	
Body Temperature during Soldering		+260	°C	IPC/JEDEC J-STD-020
Junction to Ambient Thermal Resistance (θ <sub>JA</sub> ) <sup>2</sup>		87	°C/W	
Moisture Sensitive Level		1		Represents a max. floor life time of <i>unlimited</i>
<b>Recommended Operating Conditions</b>				
Recommended charge pump load current	0	100	mA	

1. Internal thermal shutdown circuitry protects the device from permanent damage. Thermal shutdown engages at T<sub>J</sub> = 150°C (typ.) and disengages at T<sub>J</sub> = 130°C (typ.).

2. Junction to ambient thermal resistance is highly application and board-layout dependent. In applications where high maximum power dissipation exists, special care must be paid to thermal dissipation issues in board design.

## 6 Electrical Characteristics

$V_{BAT} = 3.6V$ ,  $V_{EN} = 1.65V$ ,  $C_{BAT} = C_{VCP\text{OUT}} = 1.0\mu F$ ,  $C_{FLY1-2} = 0.47\mu F$ ,  $T_{AMB} = -30^{\circ}C$  to  $+85^{\circ}C$ , typical values @  $T_{AMB} = +25^{\circ}C$  (unless otherwise specified)<sup>1</sup>.

Table 3. Electrical Characteristics

Symbol	Parameter	Condition	Min	Typ	Max	Unit
<b>General Operating Conditions</b>						
$V_{BAT}$	Supply Voltage		2.7		5.5	V
$I_{VBAT}$	Standby supply current	EN = 0V or CHIP_EN=0 (bit), external 32 kHz clock running or not running		1.4	4	$\mu A$
		External 32 kHz clock running, charge pump and current source outputs disabled		0.16	0.22	mA
	Normal Mode supply current	Charge pump in 1x mode, no load, current source outputs disabled		0.16	0.22	mA
		Charge pump in 1.5x mode, no load, current source outputs disabled		1.4		mA
	Power Save Mode supply current	External 32 kHz clock running		3.1	5	$\mu A$
		Internal oscillator running		0.16	0.23	mA
$f_{OSC}$	Internal Oscillator Frequency Accuracy	$T_{AMB} = +25^{\circ}C$	-4		+4	%
			-7		+7	
$T_{AMB}$	Operating Temperature <sup>1</sup>		-30	25	85	$^{\circ}C$
<b>Charge Pump</b>						
$R_{OUT}$	Charge Pump Output Resistance	Gain = 1.5 and $V_{BAT} = 2.9V$		6		$\Omega$
		Gain = 1 and $V_{BAT} = 2.9V$		1		
		Gain = 1.5 and $V_{BAT} = 3.6V$		1.4		
		Gain = 1 and $V_{BAT} = 3.6V$		1		
$f_{SW}$	Switching Frequency		1.2	1.25	1.3	MHz
$I_{GND}$	Ground current	Gain = 1.5		1.2		mA
		Gain = 1		1		$\mu A$
$t_{ON}$	$V_{CP}$ Turn-On Time <sup>2</sup>	$V_{BAT} = 3.6V$ , $I_{OUT} = 60\text{ mA}$		100		$\mu s$
$I_{LOAD}$	Charge Pump load current	Recommended charge pump load current	0		100	mA
<b>LED Driver</b>						
$I_{LEAK}$	Leakage Current (LED1 to LED9)	PWM = 0%		0.1	1	$\mu A$
$I_{MAX}$	Maximum Source Current	Outputs LED1 to LED9		25.5		mA
$I_{OUT}$	Output Current <sup>3</sup> Accuracy	Output Current set to 17.5 mA	$T_{AMB} = +25^{\circ}C$	-2.5%	+2.5%	%
				-5	+5	
$I_{MATCH}$	Matching	Output Current set to 17.5 mA		1	2.5	%
$f_{LED}$	LED Switching Frequency			312		Hz
$V_{SAT}$	Saturation Voltage <sup>4</sup>	Output Current set to 17.5 mA		45	100	mV
<b>LED Test</b>						



Table 3. Electrical Characteristics (Continued)

Symbol	Parameter	Condition	Min	Typ	Max	Unit
LSB	Least Significant Bit			30		mV
EABS	Total Unadjusted Error <sup>5</sup>	$V_{IN\_TEST} = 0V \text{ to } V_{BAT}$		$<\pm 3$	$\pm 4$	LSB
tCONV	Conversion Time			2.7		ms
VIN_TEST	DC Voltage Range		0		5	V
<b>Logic Interface</b>						
Logic Input EN						
VIL	Input Low Level				0.5	V
VIH	Input High Level		1.2			V
IIN	Input Current		-1.0		1.0	$\mu A$
tDELAY	Input Delay <sup>6</sup>			2		$\mu s$
Logic Input SCL, SDA, TRIG, CLK32K, ASEL0, ASEL1						
VIL	Input Low Level				$0.2 \times V_{EN}$	V
VIH	Input High Level		$0.8 \times V_{EN}$			V
IIN	Input Current		-1.0		1.0	$\mu A$
Logic Output SDA, TRIG, INT						
VOL	Output Low Level	$I_{OUT} = 3 \text{ mA (pull-up current)}$		0.3	0.5	V
IL	Output Leakage Current	$V_{CP} = 2.8V$			1.0	$\mu A$
Logic Output GPO						
VOL	Output Low Level	$I_{OUT} = 3 \text{ mA}$		0.3	0.5	V
VOH	Output High Level	$I_{OUT} = -2 \text{ mA}$	$V_{BAT} - 0.5$	$V_{BAT} - 0.3$		V
IL	Output Leakage Current	$V_{CP} = 2.8V$			1.0	$\mu A$
Logic Input CLK32K						
fCLK	Clock Frequency			32.7		kHz
fCLKH	High Time		6			$\mu s$
fCLKL	Low Time		6			$\mu s$
tR	Clock Rise Time	10 to 90%			2	$\mu s$
tF	Clock Fall Time	90 to 10%			2	$\mu s$

1. In applications where high power dissipation and/or poor package thermal resistance is present, the maximum ambient temperature may have to be derated. Maximum ambient temperature ( $T_{Amb-MAX}$ ) is dependent on the maximum operating junction temperature ( $T_{J-MAX} = 125^{\circ}C$ ), the maximum power dissipation of the device in the application ( $P_{D-MAX}$ ) and the junction to ambient thermal resistance of the part/package in the application ( $\theta_{JA}$ ) as given by the following equation:  $T_{Amb-MAX} = T_{J-MAX} - (\theta_{JA} * P_{D-MAX})$ .
2. Turn-on time is measured from the moment the charge pump is activated until the  $V_{CP}$  crosses 90% of its target value

1. Low-ESR Surface-Mount Ceramic Capacitors (8MLCCs) used in setting electrical characteristics.

3. Output current accuracy is the difference between actual value of the output current and programmed value of this current. IMATCH is determined as follows:

For the constant current D1 to D9, the following are determined: The maximum current (max) and the minimum current (min), then the IMATCH is calculated with:  $IMATCH = 100 * (((max-min)/2) + ((max+min)/2)) / ((max+min)/2) - 100$

4. Saturation voltage is defined as the voltage when the LED current has dropped 10% from the value measured at  $V_{CP} - 1V$ .

5. Total unadjusted error includes offset, full-scale and linearity errors.

6. The I2C host should allow at least 500µs before sending data the AS3661 after the rising edge of the enable line.

Figure 3. I<sup>2</sup>C mode Timing Diagram

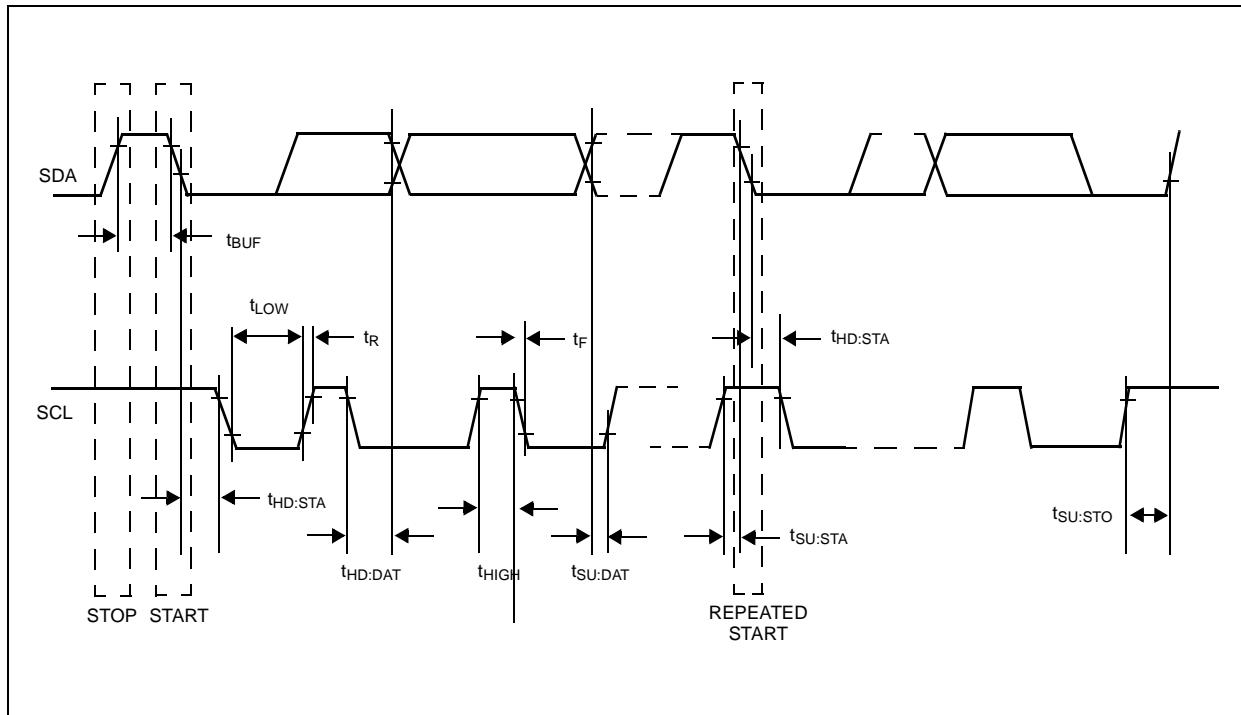

Table 4. Electrical Characteristics I<sup>2</sup>C<sup>1</sup>

Symbol	Parameter	Condition	Min	Typ	Max	Unit
<b>I<sup>2</sup>C mode timings - see Figure 3 on page 10</b>						
fSCLK	SCL Clock Frequency		0		400	kHz
t <sub>BUF</sub>	Bus Free Time Between a STOP and START Condition		1.3			µs
t <sub>HD:STA</sub>	Hold Time (Repeated) START Condition <sup>2</sup>		0.6			µs
t <sub>LOW</sub>	LOW Period of SCL Clock		1.3			µs
t <sub>HIGH</sub>	HIGH Period of SCL Clock		0.6			µs

Table 4. Electrical Characteristics (Continued)<sup>2</sup>C<sup>1</sup>

Symbol	Parameter	Condition	Min	Typ	Max	Unit
t <sub>SU:STA</sub>	Setup Time for a Repeated START Condition		0.6			μs
t <sub>HD:DAT</sub>	Data Hold Time <sup>3</sup>		50			ns
t <sub>SU:DAT</sub>	Data Setup Time <sup>4</sup>		100			ns
t <sub>R</sub>	Rise Time of Both SDA and SCL Signals		20 + 0.1C <sub>B</sub>		300	ns
t <sub>F</sub>	Fall Time of Both SDA and SCL Signals		15 + 0.1C <sub>B</sub>		300	ns
t <sub>SU:STO</sub>	Setup Time for STOP Condition		0.6			μs
C <sub>B</sub>	Capacitive Load for Each Bus Line	Load of one Picofarad corresponds to one nanosecond.	10		200	ns
C <sub>I/O</sub>	I/O Capacitance (SDA, SCL)				10	pF

1. Specification is guaranteed by design and is not tested in production. V<sub>EN</sub> = 1.65V to V<sub>BAT</sub>.
2. After this period the first clock pulse is generated.
3. A device must internally provide a hold time of at least 300ns for the SDA signal (referred to the V<sub>IHMIN</sub> of the SCL signal) to bridge the undefined region of the falling edge of SCL.
4. A fast-mode device can be used in a standard-mode system, but the requirement t<sub>SU:DAT</sub> = to 250ns must then be met. This is automatically the case if the device does not stretch the LOW period of the SCL signal. If such a device does stretch the LOW period of the SCL signal, it must output the next data bit to the SDA line t<sub>R</sub> max + t<sub>SU:DAT</sub> = 1000 + 250 = 1250ns before the SCL line is released.

## 7 Typical Operating Characteristics

VBAT = 3.6V, VEN = 1.65V, CBAT = CVCPOUT = 1.0μF, CFLY1-2 = 0.47μF, TAMB = +25°C, unless otherwise specified

Figure 4. Charge Pump 1.5 x Efficiency vs. Load

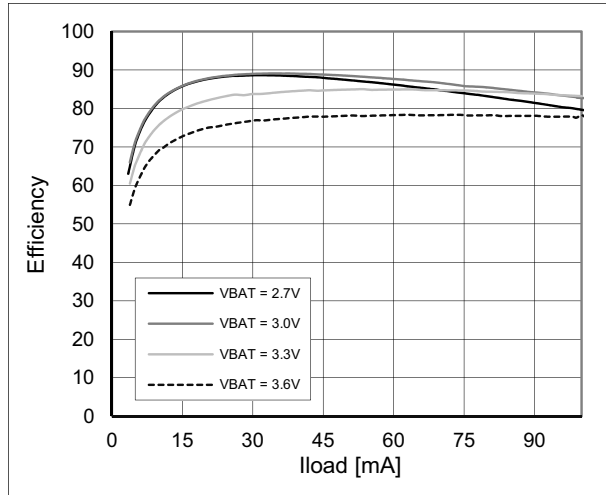

Figure 5. Output Voltage vs. Load Current (1.5 x CP)

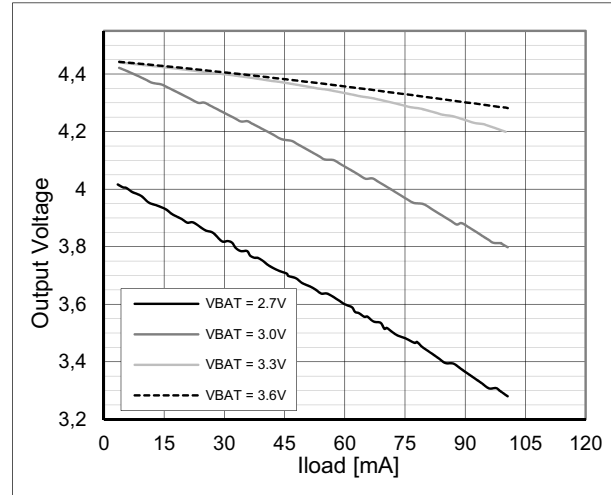

Figure 6. Gain Change Hysteresis Loop (6x1mA load)

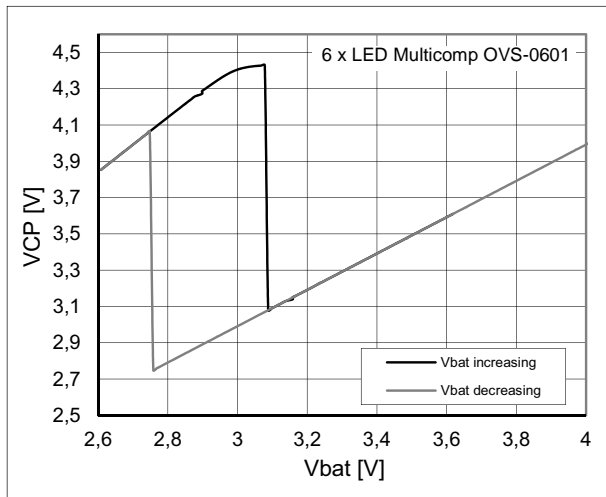

Figure 7. Effect of adap. hyst. on width of hyst. loop

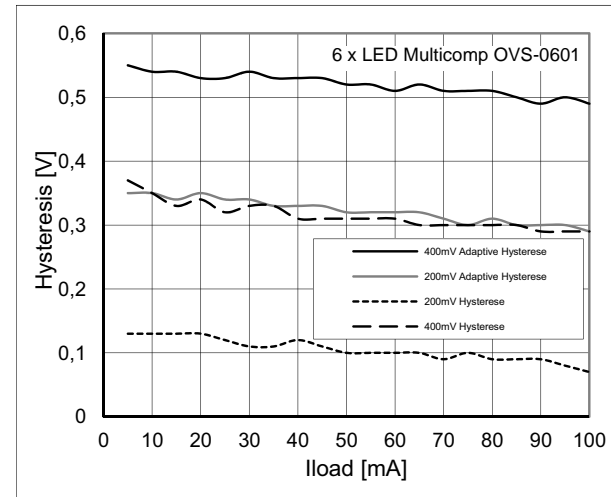

Figure 8. LED Current matching distribution @ 17.5mA

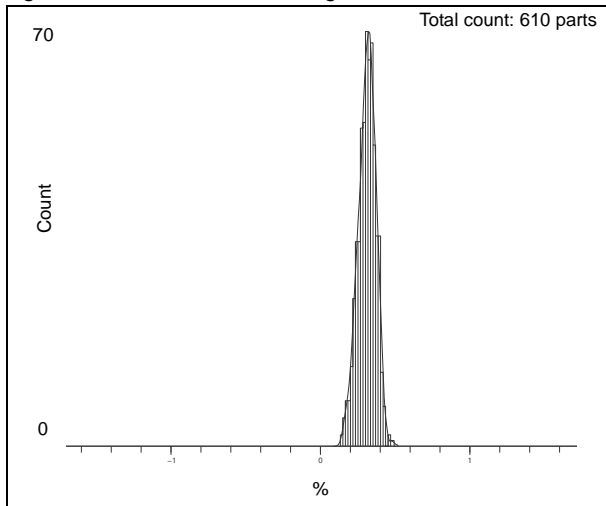

Figure 9. LED current Accuracy distribution @ 17.5mA

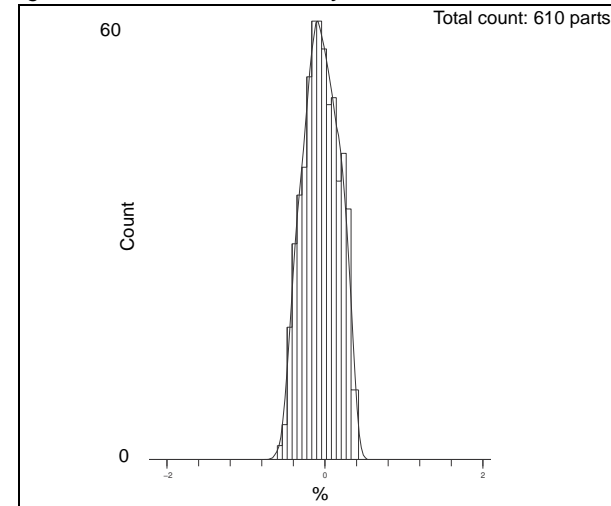

Figure 10. Power Save Mode Supply Current vs. VBAT, Charge Pump in 1x mode

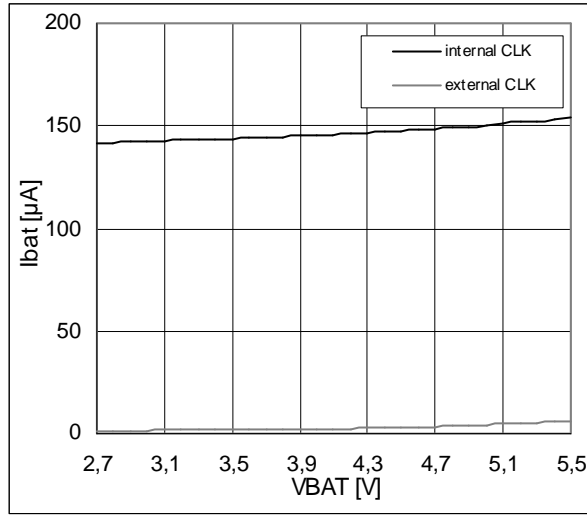

Figure 11. Serial Bus Write and Charge Pump Start-up, ILOAD = 60mA

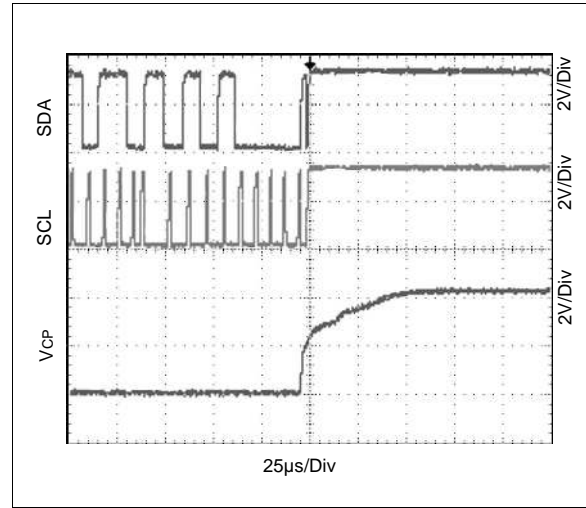

Figure 12. Line Trans. and Charge Pump autom. Gain Change 1.5 to 1, 6LEDs@1mA 100% PWM

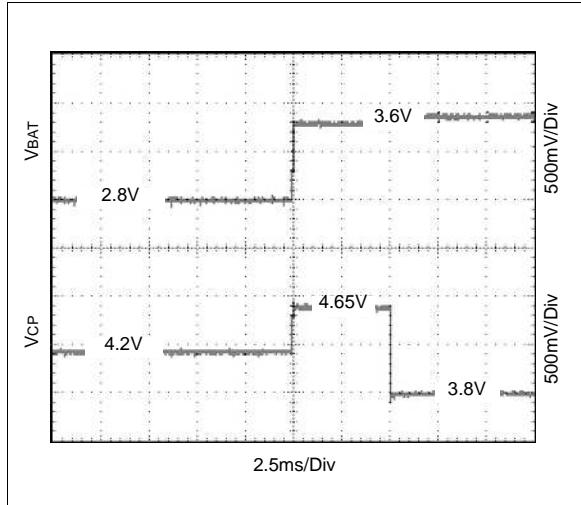

Figure 13. Line Trans. and Charge Pump autom. Gain Change 1 to 1.5, 6LEDs@1mA 100% PWM

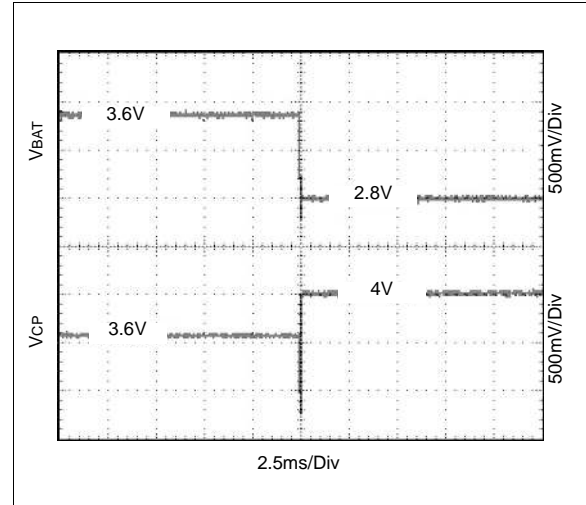

Figure 14. 100% PWM RGB LED Efficiency vs. VBAT

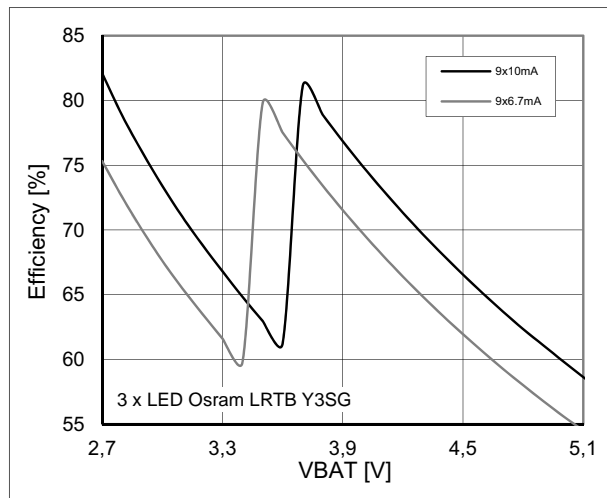
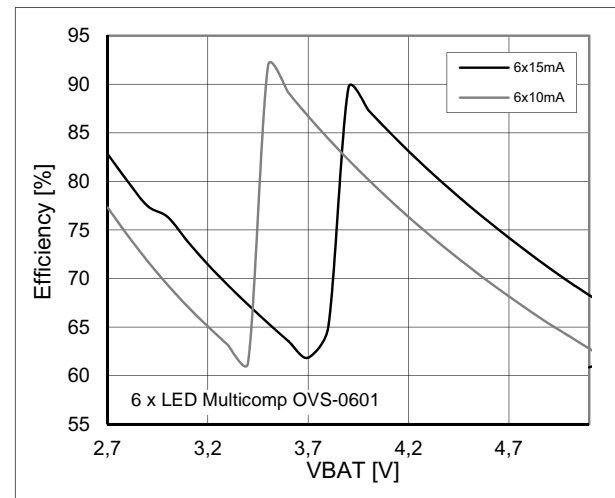

Figure 15. 100% PWM WLED Efficiency vs. VBAT



## 8 Detailed Description

The AS3661 is a fully integrated lighting management unit for producing lighting effects for mobile devices. The AS3661 includes all necessary power management, high-side current sources, temperature compensation, two wire control interface and programmable pattern generators. The overall maximum current for each driver is set by an 8-bit register. The AS3661 controls LED luminance with a pulse width modulation (PWM) scheme with a resolution of 12 bits. The temperature compensation is also done by a PWM.

### 8.1 Programming

The AS3661 provides flexibility and programmability for dimming and sequencing control. Each LED can be controlled directly and independently through the serial bus or LED drivers can be grouped together for pre-programmed flashing patterns. The AS3661 has three independent program execution engines, so it is possible to form three independently programmable LED banks. LED drivers can be grouped based on their function so that, for example, the first bank of drivers can be assigned to the keypad illumination, the second bank to the “funlights” and the third group to the indicator LED(s). Each bank can contain 1 to 9 LED driver outputs. Instructions for program execution engines are stored in the program memory. The total amount of the program memory is 96 instructions and the user can allocate the memory as required by the engines.

### 8.2 LED Error Detection

AS3661 has a built-in LED error detection. Error detection does not only detect open and short circuit, but provides an opportunity to measure the  $V_f$ 's of the LEDs. The test event is activated by a serial interface write and the result can be read through the serial interface during the next cycle. This feature can also be addressed to measure the voltage on VBAT, VCP and INT pins. Typical example usage includes monitoring battery voltage or using INT pin as a light sensor interface.

### 8.3 Energy Efficiency

When charge pump automatic mode selection is enabled, the AS3661 monitors the voltage over the drivers of LED1 to LED6 so that the device can select the best charge pump gain and maintain good efficiency over the whole operating voltage range. The red LED element of an RGB LED typically has a forward voltage of about 2V. For that reason, the outputs LED7, LED8 and LED9 are internally powered by VBAT, since battery voltage is high enough to drive red LEDs over the whole operating voltage range. This allows to drive three RGB LEDs with good efficiency because the red LEDs doesn't load the charge pump. AS3661 is able to automatically enter power-save mode, when LED outputs are not active and thus lowering idle current consumption down to 10  $\mu$ A (typ.). During the “downtime” of the PWM cycle (constant current output status is low) additional power savings can be achieved when the PWM power save feature is enabled.

### 8.4 Temperature Compensation

The luminance of an LED is typically a function of its temperature even though the current flowing through the LED remains constant. Since luminance is temperature dependent, many LED applications require some form of temperature compensation to decrease luminance and color purity variations due to temperature changes. The AS3661 has a built in temperature sensing element and PWM duty cycle of the LED drivers changes linearly in relationship to changes in temperature. User can select the slope of the graph (31 slopes) based on the LED characteristics. This compensation can be done either constantly, or only right after when the device wakes up from power save mode, to avoid error due to self-heating of the device. Linear compensation is considered to be practical and accurate enough for most LED applications. Compensation is effective over the temperature range from -40°C to +90°C.

Figure 16. Temperature Compensation Principle

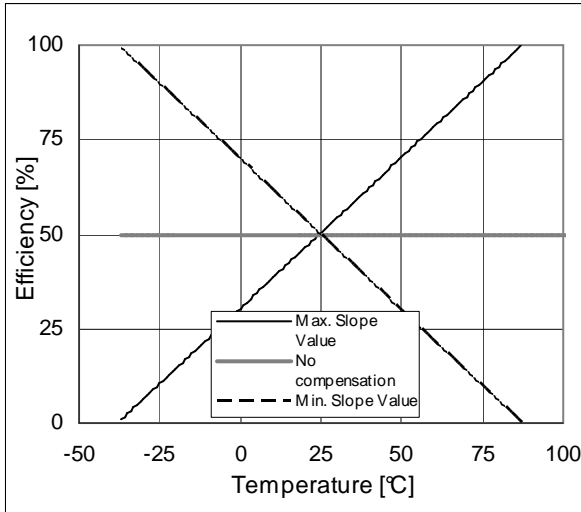
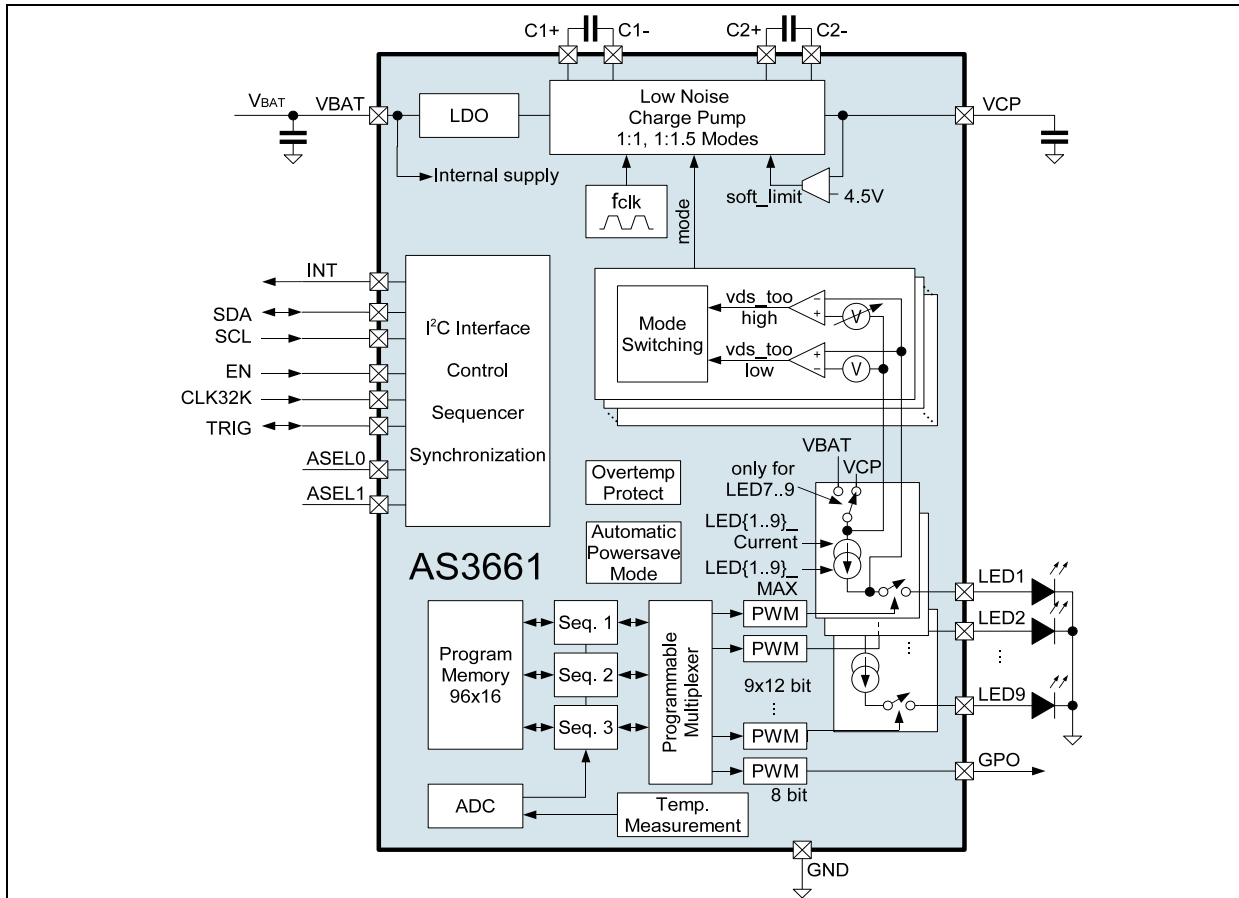

Figure 17. AS3661 - Block Diagram



## 8.5 Modes of Operation

The following are the different modes of operation of AS3661

### 8.5.1 RESET

In the RESET mode all the internal registers are reset to the default values. Reset is entered always if Reset Register (3DH) is written FFH or internal Power On Reset is active. Power On Reset (POR) will activate during the chip startup or when the supply voltage VBAT fall below 1.5V (typ.). Once VBAT rises above 1.5V (typ.) POR will be inactivate and the chip will continue to the STANDBY mode. CHIP\_EN control bit is low after POR by default.

### 8.5.2 STANDBY

The STANDBY mode is entered if the register bit CHIP\_EN or EN pin is logic low and Reset is not active. This is the low power consumption mode, when all circuit functions are disabled. Registers can be written in this mode if EN pin is logic high so that the control bits will be effective right after the start up.

### 8.5.3 STARTUP

When CHIP\_EN bit is written high and the EN pin is high, the INTERNAL STARTUP SEQUENCE powers up all the needed internal blocks (VREF, Bias, Oscillator etc.). Startup delay is 500  $\mu$ s. If the chip temperature rises too high, the Thermal Shutdown (TSD) disables the chip operation and chip waits in STARTUP mode until no thermal shutdown event is present.

### 8.5.4 NORMAL

During NORMAL mode the user controls the chip using the Control Registers.

### 8.5.5 POWER SAVE

In POWER SAVE mode analog blocks are disabled to minimize power consumption. ([see Automatic Power Save Mode on page 19](#))

Figure 18. Mode Select

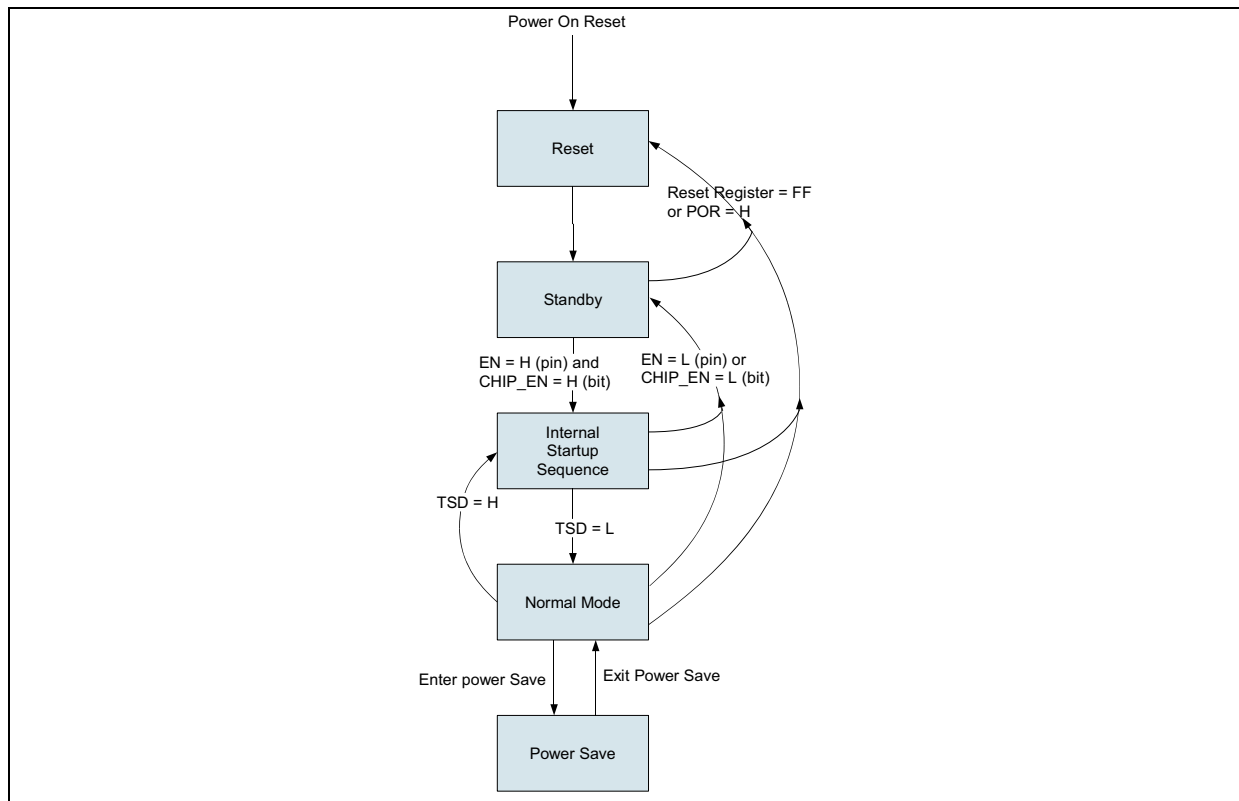



## 8.6 Charge Pump Operational Description

### 8.6.1 Overview

The AS3661 includes a pre-regulated switched-capacitor charge pump with a programmable voltage multiplication of 1 and 1.5x. In 1.5x mode by combining the principles of a switched-capacitor charge pump and a linear regulator, it generates a regulated 4.5V output from Li-Ion input voltage range. A two-phase non-overlapping clock generated internally controls the operation of the charge pump. During the charge phase, both flying capacitors (CFLY1 and CFLY2) are charged from input voltage. In the pump phase that follows, the flying capacitors are discharged to output. A traditional switched capacitor charge pump operating in this manner will use switches with very low on-resistance, ideally  $0\Omega$ , to generate an output voltage that is 1.5x the input voltage. The AS3661 regulates the output voltage by controlling the resistance of the input-connected pass-transistor switches in the charge pump.

Figure 19. Charge Pump

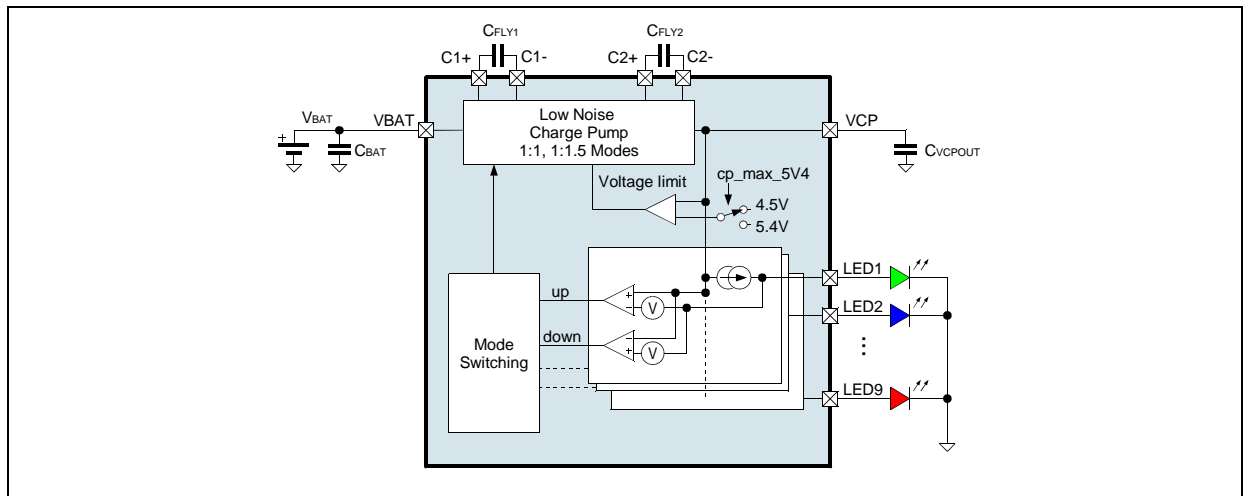

### 8.6.2 Output Resistance

At lower input voltages, the charge pump output voltage may degrade due to effective output resistance ( $R_{OUT}$ ) of the charge pump. The expected voltage drop can be calculated by using a simple model for the charge pump illustrated in Figure 20 below.

Figure 20. Charge Pump Output Resistance

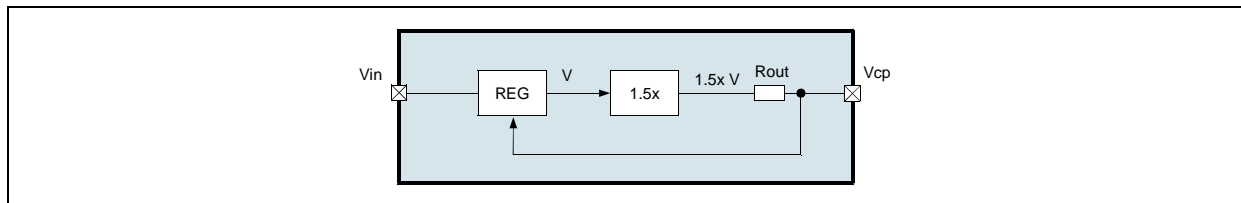

The model shows a linear pre-regulation block (REG), a voltage multiplier (1.5x), and an output resistance ( $R_{OUT}$ ). The output resistance models the output voltage drop that is inherent to switched capacitor converters. The output resistance is  $3.5\Omega$  (typ.), and it is a function of switching frequency, input voltage, flying capacitors' capacitance value, internal resistances of the switches and ESR of the flying capacitors. When the output voltage is in regulation, the regulator in the model controls the voltage  $V$  to keep the output voltage equal to 4.5V (typ.). With increased output current, the voltage drop across  $R_{OUT}$  increases. To prevent drop in output voltage, the voltage drop across the regulator is reduced,  $V$  increases, and  $V_{CP}$  remains at 4.5V. When the output current increases to the point that there is zero voltage drop across the regulator,  $V$  equals the input voltage, and the output voltage is "on the edge" of regulation. Additional output current causes the output voltage to fall out of regulation, so that the operation is similar to a basic open-loop 1.5x charge pump. In this mode, output current results in output voltage drop proportional to the output resistance of the charge pump. The out-of-regulation output voltage can be approximated by:

$$V_{CP} = 1.5 \times V_{IN} - I_{OUT} \times R_{OUT}$$

### 8.6.3 Controlling the Charge Pump

The charge pump is controlled with two CP\_MODE bits in MISC register (address 36H). When both of the bits are low, the charge pump is disabled and the output voltage is pulled down with an internal 300 k $\Omega$  (typ.) resistor. The charge pump can be forced to bypass mode, so that the battery voltage is connected directly to the current sources. In 1.5x mode the output voltage is boosted to 4.5V. In automatic mode the charge pump operation mode is determined by saturation of constant current drivers, like described in chapter LED Forward Voltage Monitoring.

### 8.6.4 LED Forward Voltage Monitoring

When the charge pump automatic mode selection is enabled, the voltages over the LED drivers LED1 to LED6 are monitored.

**Note:** Power input for current source outputs LED7, LED8 and LED9 are internally connected to the VBAT pin.

If the LED1 to LED6 drivers do not have enough headroom, the charge pump gain is set to 1.5x. Driver saturation monitor does not have a fixed voltage limit, since saturation voltage is a function of temperature and current. The charge pump gain is set to 1x, when the battery voltage is high enough to supply all LEDs. In automatic gain change mode, the charge pump is switched to bypass mode (1x), when LEDs are inactive for over 50 ms.

### 8.6.5 Gain Change Hysteresis

The charge pump gain control utilizes digital filtering to prevent supply voltage disturbances (for example, the transient voltage on the power supply during the GSM burst) from triggering unnecessary gain changes. Hysteresis is provided to prevent periodic gain changes, which would occur due to LED driver and charge pump voltage drop in 1x mode. The hysteresis of the gain change is user configurable, default setting is factory programmable. Flexible configuration ensures, that the hysteresis can be minimized or set to desired level in each application. LED forward voltage monitoring and gain control block diagram is shown in [Figure 21](#).

Figure 21. Forward Voltage Monitoring and Gain Control Block

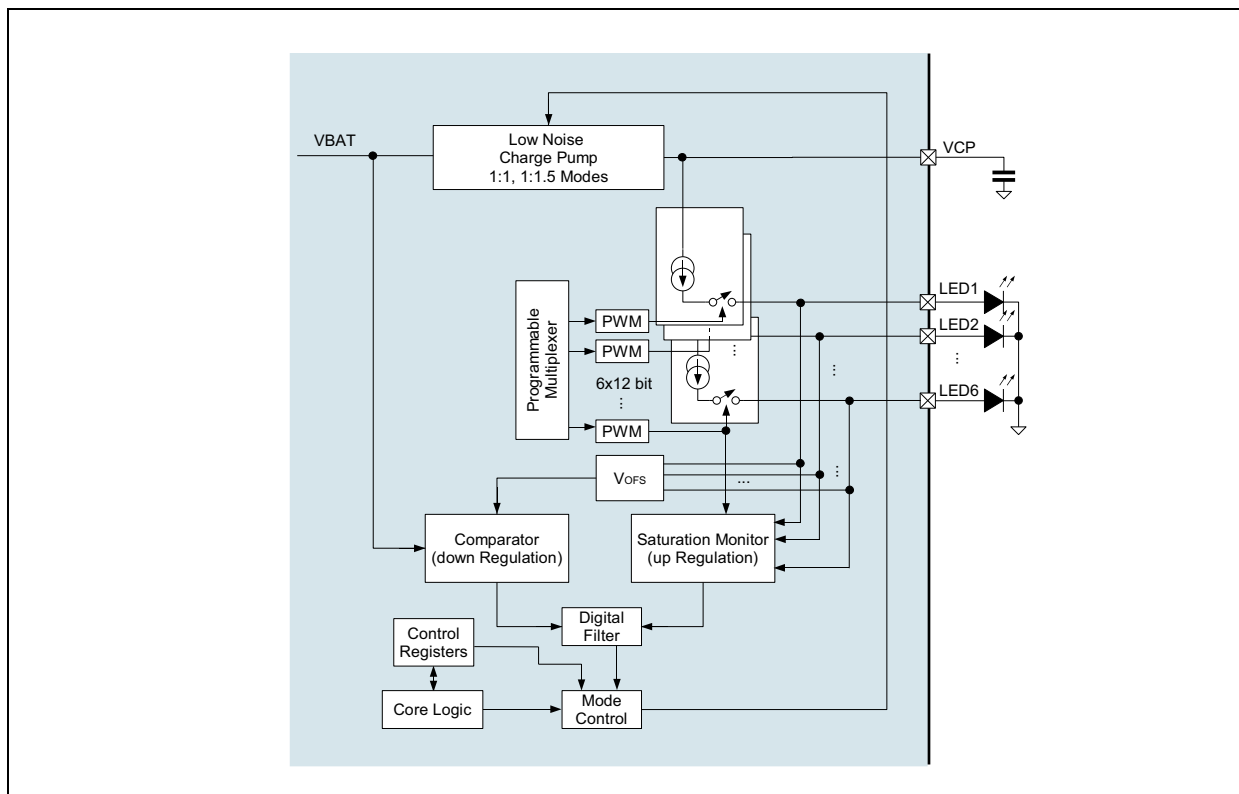

### 8.6.6 Automatic Power Save Mode

Automatic power save mode is enabled when POWERSAVE\_EN bit in register address 36H is '1'. Almost all analog blocks are powered down in power save, if an external clock signal is used. Only the charge pump protection circuits remain active. However, if the internal clock has been selected, only charge pump and LED drivers are disabled during the power save; the digital part of the LED controller needs stay active. In both cases the charge pump enters to the weak 1x mode. In this mode the charge pump utilizes a passive current limited keep-alive switch, which keeps the output voltage at the battery level. During the program execution AS3661 can enter power save if there is no PWM activity in any of the LED driver outputs. To prevent short power save sequences during program execution, AS3661 has an instruction look-ahead filter. During program execution engine 1, engine 2 and engine 3 instructions are constantly analyzed, and if there is time intervals of more than 50ms in length with no PWM activity on LED driver outputs, the device will enter power save. In power save mode program execution continues uninterruptedly. When an instruction that requires PWM activity is executed, a fast internal startup sequence will be started automatically.

### 8.6.7 PWM Power Save Mode

PWM cycle power save mode is enabled when register 36 bit [2] PWM\_PS\_EN is set to '1'. In PWM power save mode analog blocks are powered down during the "down time" of the PWM cycle. Blocks that are powered down depends whether external or internal clock is used. While the Automatic Power Save Mode (see above) saves energy when there is no PWM activity at all, the PWM Power Save mode saves energy during PWM cycles. Like the Automatic Power Save Mode, PWM Power Save Mode works also during program execution.

Figure 22. PWM Powersave Principle with external clock ( $V_{DD} = 3.6V$ , 50% PWM,  $I_{LEDg} = 5mA$ )

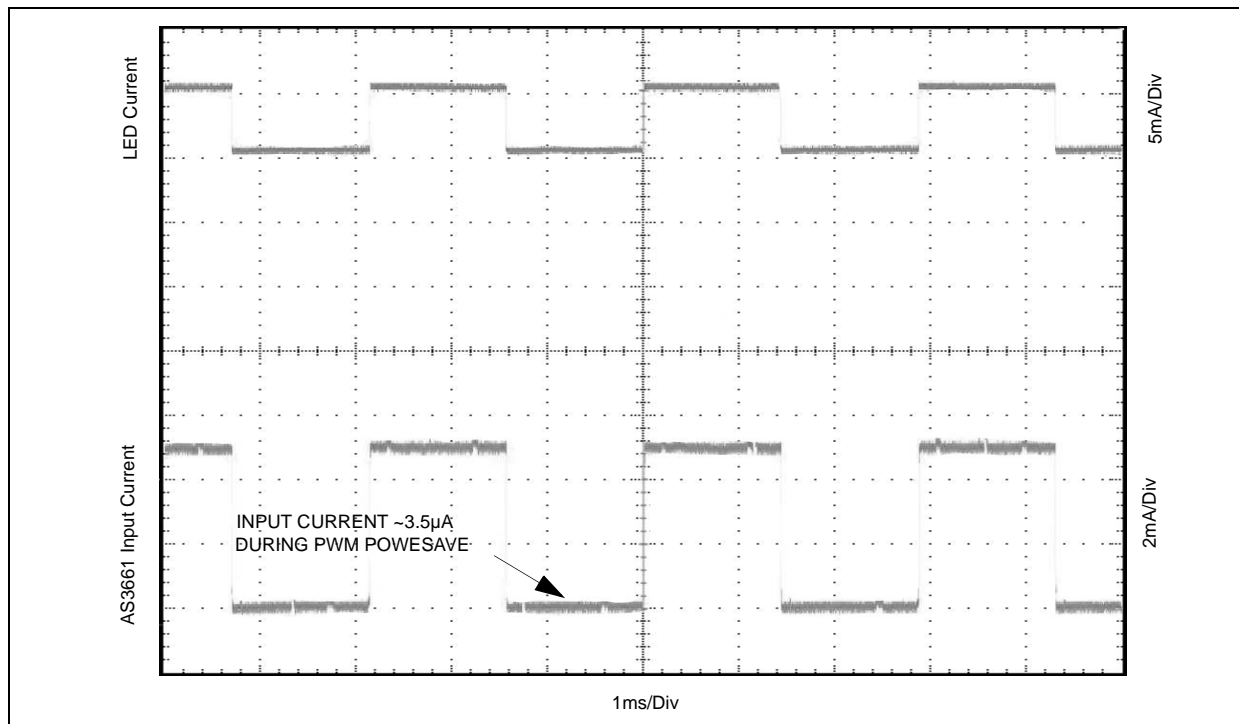

## 8.7 LED Driver Operational Description

AS3661 LED drivers are constant current sources. The output current can be programmed by control registers up to 25.5 mA. The overall maximum current is set by 8-bit output current control registers with 100  $\mu$ A step size. Each of the 9 LED drivers has a separate output current control register. The LED luminance pattern (dimming) is controlled with PWM (pulse width modulation) technique, which has internal resolution of 12 bits (8-bit control can be seen by user). PWM frequency is 312 Hz (see Figure 23 on page 20).

Figure 23. LED Pattern and Current Control Principle

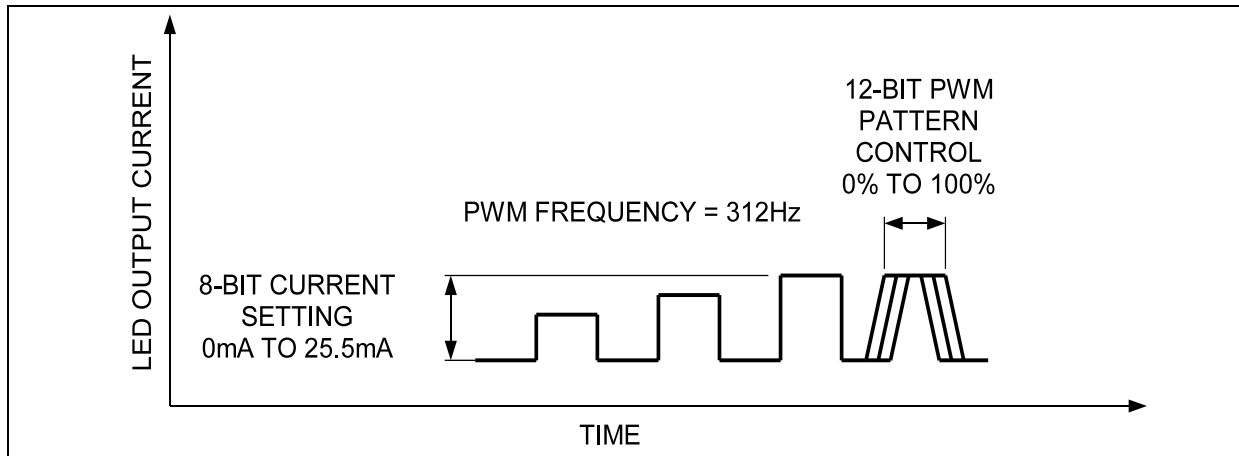

LED dimming is controlled according to a logarithmic or linear scale (see Figure 24). Logarithmic or linear scheme can be set for both the program execution engine control and direct PWM control.

Figure 24. Logarithmic vs. Linear Dimming

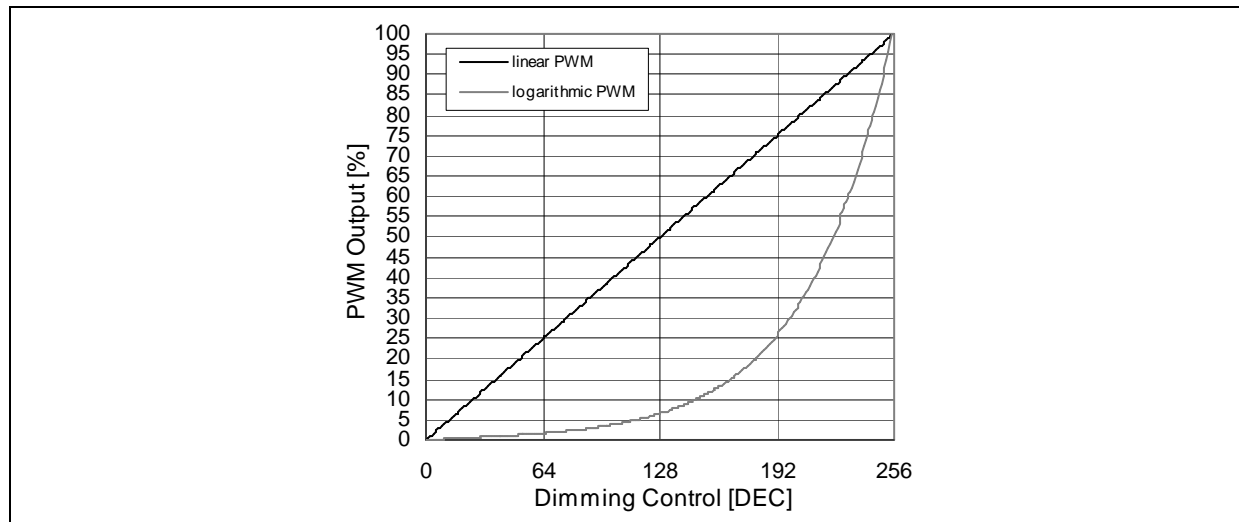

**Note:** If the temperature compensation is active, the maximum PWM duty cycle is limited to 50% at +25°C. This is required to allow enough headroom for temperature compensation over the whole temperature range -40 °C to 90°C.

### 8.7.1 Powering LEDs

Although the AS3661 is very suitable for white LED and general purpose applications, it is particularly well suited to use with RGB LEDs. The AS3661 architecture is optimized for use with three RGB LEDs. Typically, the red LEDs have forward voltages below 2V and thus red LEDs can be powered directly from V<sub>BAT</sub>. In AS3661 the LED7, LED8 and LED9 drivers are directly powered from the battery voltage (V<sub>BAT</sub>), not from the charge pump output. The LED1 to LED6 drivers are internally connected to the charge pump output and these outputs can be used for driving green and blue (V<sub>F</sub> = 2.7V to 3.7V) or white LEDs. Of course, LED7, LED8 and LED9 outputs can be used for green, blue or white LEDs if the V<sub>BAT</sub> voltage is high enough. An RGB LED configuration example is given in the Typical Applications section.

### 8.7.2 Controlling the High-side LED Drivers

- Direct PWM Control

All AS3661 LED drivers, LED1 to LED9, can be controlled independently through the two-wire serial I<sup>2</sup>C compatible interface. For each high-side driver there is a PWM control register. Direct PWM control is active by default.

- Controlling by Program Execution Engines

Engine control is used when the user wants to create programmed sequences. The program execution engine has higher priority than direct control registers. Therefore if the user has set to PWM register a certain value it will be automatically overridden when the program execution engine controls the driver. LED control and program execution engine operation is described in the chapter Control Register Details.

- Master Fader Control

In addition to LED-by-LED PWM register control, the AS3661 is equipped with so called master fader control, which allows the user to fade in or fade out multiple LEDs by writing to only one register. This is an useful function to minimize serial bus traffic between the MCU and the AS3661. The AS3661 has three master fader registers, so it is possible to form three master fader groups. Master fader control can be used with the engines as well.

## 8.8 I<sup>2</sup>C Compatible Control Interface

The AS3661 supports the I<sup>2</sup>C bus protocol. A device that sends data onto the bus is defined as a transmitter and a device receiving data as a receiver. The device that controls the message is called a master. The devices that are controlled by the master are referred to as slaves. A master device that generates the serial clock (SCL), controls the bus access, and generates the START and STOP conditions must control the bus. The AS3661 operates as a slave on the I<sup>2</sup>C bus. Within the bus specifications a standard mode (100kHz maximum clock rate) and a fast mode (400kHz maximum clock rate) are defined. The AS3661 works in both modes. Connections to the bus are made through the open-drain I/O lines SDA and SCL [Table 5](#)

### 8.8.1 I<sup>2</sup>C Address selection

The slave address can be selected depending on the connection of the two address selection pins ASEL0 and ASEL1. The selected address for reading and writing depending on the state of ASEL0 and ASEL1 can be found in [Table 5](#) below.

Table 5. Chip Address Configuration

ASEL1	ASEL0	Address	8 bit Hex Address
		(Hex)	R/W
GND	GND	32	64/65
GND	VEN	33	66/67
VEN	GND	34	68/69
VEN	VEN	35	6A/6B

The following bus protocol has been defined ([Figure 25](#)):

- Data transfer may be initiated only when the bus is not busy.
- During data transfer, the data line must remain stable whenever the clock line is HIGH. Changes in the data line while the clock line is HIGH are interpreted as control signals.

Accordingly, the following bus conditions have been defined:

### 8.8.2 Bus Not Busy

Both data and clock lines remain HIGH.

### 8.8.3 Start Data Transfer

A change in the state of the data line, from HIGH to LOW, while the clock is HIGH, defines a START condition.

### 8.8.4 Stop Data Transfer

A change in the state of the data line, from LOW to HIGH, while the clock line is HIGH, defines the STOP condition.

### 8.8.5 Data Valid

The state of the data line represents valid data when, after a START condition, the data line is stable for the duration of the HIGH period of the clock signal. The data on the line must be changed during the LOW period of the clock signal. There is one clock pulse per bit of data.

Each data transfer is initiated with a START condition and terminated with a STOP condition. The number of data bytes transferred between START and STOP conditions are not limited, and are determined by the master device. The information is transferred byte-wise and each receiver acknowledges with a ninth bit.

### 8.8.6 Acknowledge

Each receiving device, when addressed, is obliged to generate an acknowledge after the reception of each byte. The master device must generate an extra clock pulse that is associated with this acknowledge bit.

A device that acknowledges must pull down the SDA line during the acknowledge clock pulse in such a way that the SDA line is stable LOW during the HIGH period of the acknowledge-related clock pulse. Of course, setup and hold times must be taken into account. A master must signal an end of data to the slave by not generating an acknowledge bit on the last byte that has been clocked out of the slave. In this case, the slave must leave the data line HIGH to enable the master to generate the STOP condition.

Figure 25. Data Transfer on I<sup>2</sup>C Serial Bus

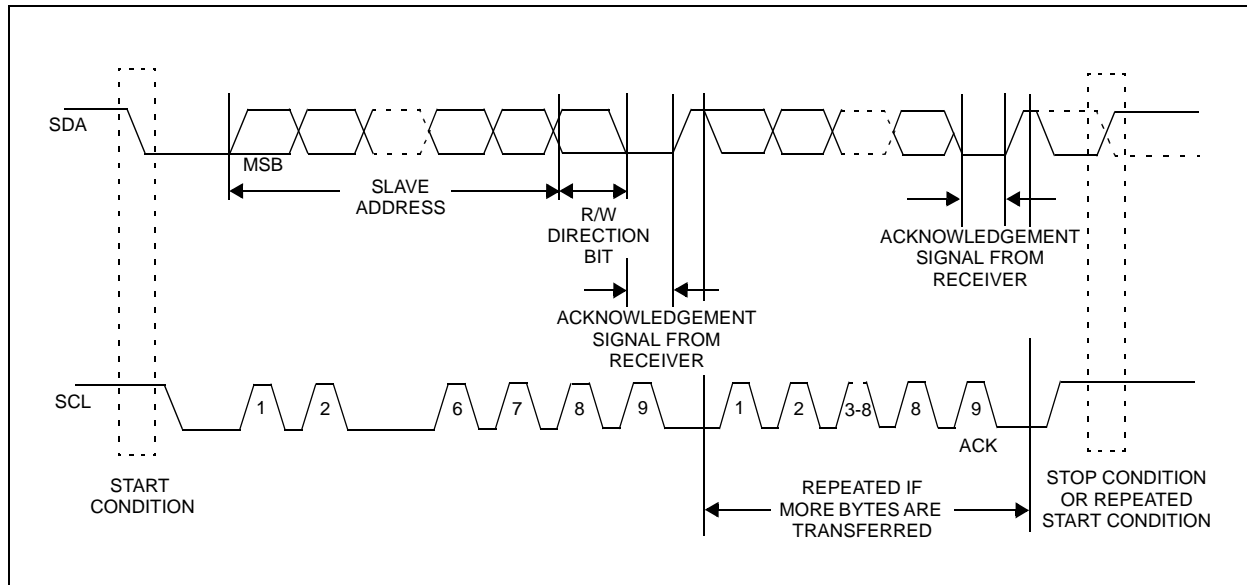

Depending upon the state of the R/W bit, two types of data transfer are possible:

1. **Data transfer from a master transmitter to a slave receiver.** The first byte transmitted by the master is the slave address. Next follows a number of data bytes. The slave returns an acknowledge bit after each received byte. Data is transferred with the most significant bit (MSB) first.
2. **Data transfer from a slave transmitter to a master receiver.** The master transmits the first byte (the slave address). The slave then returns an acknowledge bit, followed by the slave transmitting a number of data bytes. The master returns an acknowledge bit after all received bytes other than the last byte. At the end of the last received byte, a "not acknowledge" is returned. The master device generates all of the serial clock pulses and the START and STOP conditions. A transfer is ended with a STOP condition or with a repeated START condition. Since a repeated START condition is also the beginning of the next serial transfer, the bus is not released. Data is transferred with the most significant bit (MSB) first.

The AS3661 can operate in the following two modes:

1. **Slave Receiver Mode (Write Mode):** Serial data and clock are received through SDA and SCL. After each byte is received an acknowledge bit is transmitted. START and STOP conditions are recognized as the beginning and end of a serial transfer. Address recognition is performed by hardware after reception of the slave address and direction bit (see Figure 26). The slave address byte is the first byte received after the master generates the START condition. The slave address byte contains the 7-bit AS3661 address, which is 0110010<sup>2</sup>, followed by the direction bit (R/W), which, for a write, is 0.<sup>3</sup> After receiving and decoding the slave address byte the device outputs an acknowledge on the SDA line. After the AS3661 acknowledges the slave address + write bit, the master transmits a register address to the AS3661. This sets the register pointer on the AS3661. The master may then transmit zero or more bytes of data (if more than one data byte is written see also Blockwrite/read boundaries on page 24), with the AS3661 acknowledging each byte received. The

2. 'XXX' depends on the external connection of ASEL0 and ASEL1; see [Chip Address Configuration on page 22](#)

3. The address for writing to the AS3661 is 8Xh = 01100100b - see [Table 5](#)

address pointer will increment after each data byte is transferred. The master generates a STOP condition to terminate the data write.

- Slave Transmitter Mode (Read Mode):** The first byte is received and handled as in the slave receiver mode. However, in this mode, the direction bit indicates that the transfer direction is reversed. Serial data is transmitted on SDA by the AS3661 while the serial clock is input on SCL. START and STOP conditions are recognized as the beginning and end of a serial transfer (Figure 26 and Figure 27). The slave address byte is the first byte received after the master generates a START condition. The slave address byte contains the 7-bit AS3661 address, which is 0110010, followed by the direction bit (R/W), which, for a read, is 1.<sup>4</sup> After receiving and decoding the slave address byte the device outputs an acknowledge on the SDA line. The AS3661 then begins to transmit data starting with the register address pointed to by the register pointer (if more than one data byte is read see also Blockwrite/read boundaries on page 24). If the register pointer is not written to before the initiation of a read mode the first address that is read is the last one stored in the register pointer. The AS3661 must receive a “not acknowledge” to end a read.

Figure 26. Data Write - Slave Receiver Mode

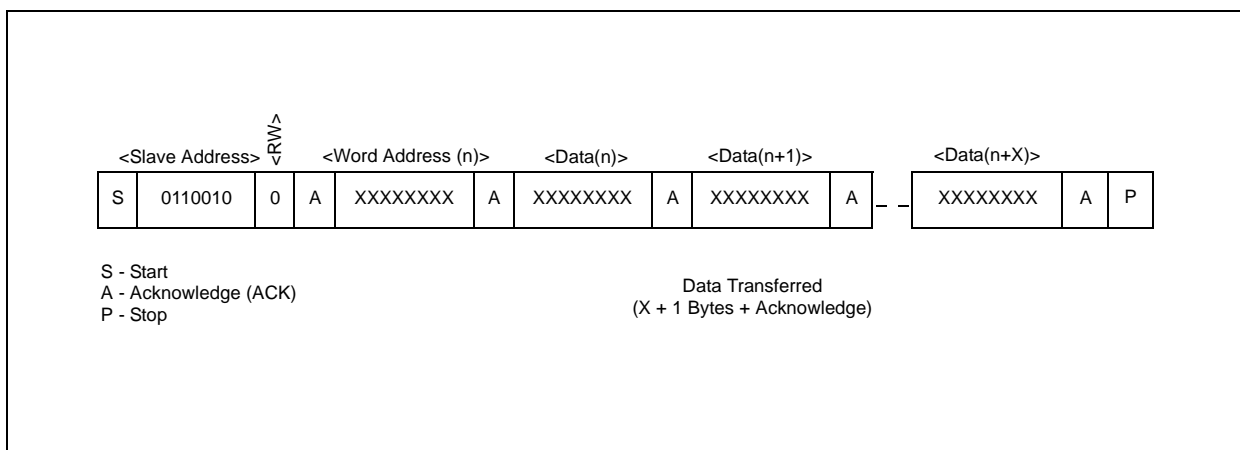
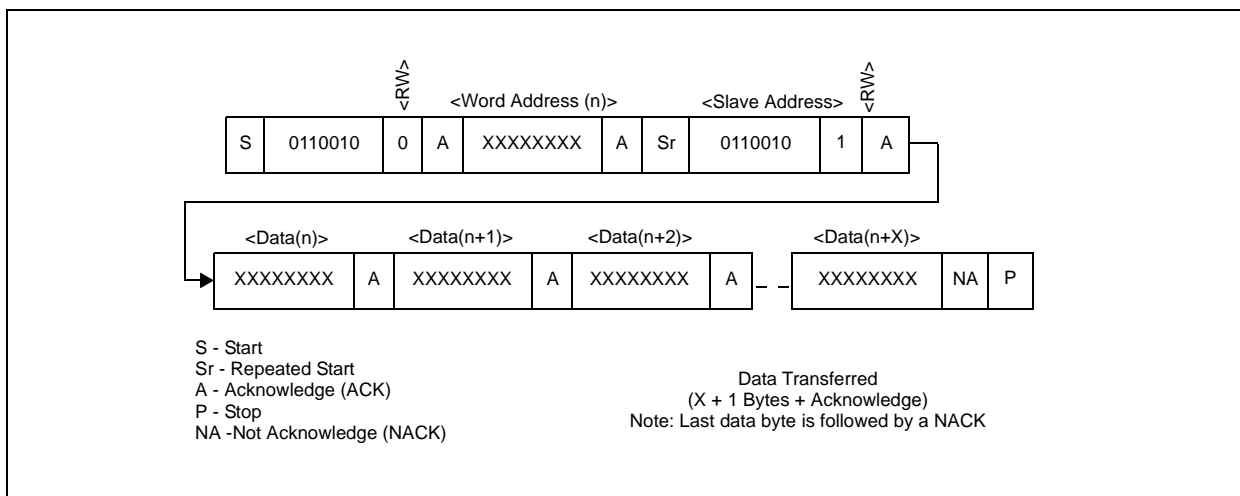

Figure 27. Data Read (Write Pointer, Then Read) - Slave Receive and Transmit



4. The address for read mode from the AS3661 is 8Xh+1 = 01100101b - see Table 5



### 8.8.7 Program Downloading

First the register `page_select` is set to the program page, which should be accessed. Then the program page (part of or full page) can be downloaded to the registers `Cmd_0_MSB`, `Cmd_0_LSB`, `Cmd_1_MSB`, `Cmd_1_LSB`...`Cmd_F_MSB`, `Cmd_F_LSB` (I<sup>2</sup>C registers area 50h to 6Fh).

Table 6. *Page\_Select Register*

Addr: 4Fh		Page_Select Register			
Bit	Bit Name	Default	Access	Description	
2:0	page_select	000b	R/W	Selects program page for download	
				000	page 0 - Addr 00h-0Fh
				001	page 1 - Addr 10h-1Fh
				010	page 2 - Addr 20h-2Fh
				011	page 3 - Addr 30h-3Fh
				100	page 4 - Addr 40h-4Fh
				101	page 5 - Addr 50h-5Fh
				110	don't use
				111	don't use

### 8.9 Register Set

The AS3661 is controlled by a set of registers through the two wire serial interface port. Some register bits are reserved for future use. Table below lists device registers, their addresses and their abbreviations. A more detailed description is given in chapter Control Register Details.

Table 7. *Description of Registers*

Hex Address	Register Name	Bit(s)	Type	Default Value After Reset	Description	
00	ENABLE / ENGINE CNTRL1	[6]	R/W	x0xxxxxx	CHIP_EN	
					0	AS3661 not enabled
					1	AS3661 enabled
		[5:4]		xx00xxxx	ENGINE1_EXEC Engine 1 program execution control	
[3:2]	xxxx00xx	ENGINE2_EXEC Engine 2 program execution control				
[1:0]	xxxxxx00	ENGINE3_EXEC Engine 3 program execution control				
01	ENGINE CNTRL2	[5:4]	R/W	xx00xxxx	ENGINE1_MODE ENGINE 1 mode control	
		[3:2]		xxxx00xx	ENGINE2_MODE ENGINE 2 mode control	
		[1:0]		xxxxxx00	ENGINE3_MODE ENGINE 3 mode control	
02	OUTPUT DIRECT/ RATIOMETRIC MSB	[0]	R/W	xxxxxxx0	LED9_RATIO_EN Enables ratiometric dimming for LED9 output	

Table 7. Description of Registers

Hex Address	Register Name	Bit(s)	Type	Default Value After Reset	Description
03	OUTPUT DIRECT/ RATIOMETRIC LSB	[7]	R/W	0xxxxxxx	LED8_RATIO_EN Enables ratiometric dimming for LED8 output
		[6]		x0xxxxxx	LED7_RATIO_EN Enables ratiometric dimming for LED7 output
		[5]		xx0xxxxx	LED6_RATIO_EN Enables ratiometric dimming for LED6 output
		[4]		xxx0xxxx	LED5_RATIO_EN Enables ratiometric dimming for LED5 output
		[3]		xxxx0xxx	LED4_RATIO_EN Enables ratiometric dimming for LED4 output
		[2]		xxxxx0xx	LED3_RATIO_EN Enables ratiometric dimming for LED3 output
		[1]		xxxxxx0x	LED2_RATIO_EN Enables ratiometric dimming for LED2 output
		[0]		xxxxxxx0	LED1_RATIO_EN Enables ratiometric dimming for LED1 output
04	OUTPUT ON/OFF CONTROL MSB	[0]	R/W	xxxxxxx1	LED9_ON ON/OFF Control for LED9 output
05	OUTPUT ON / OFF CONTROL LSB	[7]	R/W	1xxxxxxx	LED8_ON ON/OFF Control for LED8 output
		[6]		x1xxxxxx	LED7_ON ON/OFF Control for LED7 output
		[5]		xx1xxxxx	LED6_ON ON/OFF Control for LED6 output
		[4]		xxx1xxxx	LED5_ON ON/OFF Control for LED5 output
		[3]		xxxx1xxx	LED4_ON ON/OFF Control for LED4 output
		[2]		xxxxx1xx	LED3_ON ON/OFF Control for LED3 output
		[1]		xxxxxx1x	LED2_ON ON/OFF Control for LED2 output
		[0]		xxxxxxx1	LED1_ON ON/OFF Control for LED1 output
06	LED1 CONTROL	[7:6]	R/W	00xxxxxx	MAPPING Mapping for LED1 output
		[5]		xx0xxxxx	LOG_EN Logarithmic dimming control for LED1
		[4:0]		xxx00000	TEMP COMP Temperature compensation control for LED1 output
07	LED2 CONTROL	[7:6]	R/W	00xxxxxx	MAPPING Mapping for LED2 output
		[5]		xx0xxxxx	LOG_EN Logarithmic dimming control for LED2 output
		[4:0]		xxx00000	TEMP COMP Temperature compensation control for LED2 output

Table 7. Description of Registers

Hex Address	Register Name	Bit(s)	Type	Default Value After Reset	Description
08	LED3 CONTROL	[7:6]	R/W	00xxxxxx	MAPPING Mapping for LED3 output
		[5]		xx0xxxxx	LOG_EN Logarithmic dimming control for LED3 output
		[4:0]		xxx00000	TEMP COMP Temperature compensation control for LED3 output
09	LED4 CONTROL	[7:6]	R/W	00xxxxxx	MAPPING Mapping for LED4 output
		[5]		xx0xxxxx	LOG_EN Logarithmic dimming control for LED4 output
		[4:0]		xxx00000	TEMP COMP Temperature compensation control for LED4 output
0A	LED5 CONTROL	[7:6]	R/W	00xxxxxx	MAPPING Mapping for LED5 output
		[5]		xx0xxxxx	LOG_EN Logarithmic dimming control for LED5 output
		[4:0]		xxx00000	TEMP COMP Temperature compensation control for LED5 output
0B	LED6 CONTROL	[7:6]	R/W	00xxxxxx	MAPPING Mapping for LED6 output
		[5]		xx0xxxxx	LOG_EN Logarithmic dimming control for LED6 output
		[4:0]		xxx00000	TEMP COMP Temperature compensation control for LED6 output
0C	LED7 CONTROL	[7:6]	R/W	00xxxxxx	MAPPING Mapping for LED7 output
		[5]		xx0xxxxx	LOG_EN Logarithmic dimming control for LED7 output
		[4:0]		xxx00000	TEMP COMP Temperature compensation control for LED7 output
0D	LED8 CONTROL	[7:6]	R/W	00xxxxxx	MAPPING Mapping for LED8 output
		[5]		xx0xxxxx	LOG_EN Logarithmic dimming control for LED8 output
		[4:0]		xxx00000	TEMP COMP Temperature compensation control for LED8 output
0E	LED9 CONTROL	[7:6]	R/W	00xxxxxx	MAPPING Mapping for LED9 output
		[5]		xx0xxxxx	LOG_EN Logarithmic dimming control for LED9 output
		[4:0]		xxx00000	TEMP COMP Temperature compensation control for LED9 output
0F to 15		[7:0]			reserved
16	LED1 PWM	[7:0]	R/W	00000000	PWM duty cycle control for LED1
17	LED2 PWM	[7:0]	R/W	00000000	PWM duty cycle control for LED2
18	LED3 PWM	[7:0]	R/W	00000000	PWM duty cycle control for LED3

Table 7. Description of Registers

Hex Address	Register Name	Bit(s)	Type	Default Value After Reset	Description
19	LED4 PWM	[7:0]	R/W	00000000	PWM duty cycle control for LED4
1A	LED5 PWM	[7:0]	R/W	00000000	PWM duty cycle control for LED5
1B	LED6 PWM	[7:0]	R/W	00000000	PWM duty cycle control for LED6
1C	LED7 PWM	[7:0]	R/W	00000000	PWM duty cycle control for LED7
1D	LED8 PWM	[7:0]	R/W	00000000	PWM duty cycle control for LED8
1E	LED9 PWM	[7:0]	R/W	00000000	PWM duty cycle control for LED9
1F to 25		[7:0]			reserved
26	LED1 CURRENT CONTROL	[7:0]	R/W	10101111	CURRENT LED1 output current control register. Default 17.5 mA (typ.)
27	LED2 CURRENT CONTROL	[7:0]	R/W	10101111	CURRENT LED2 output current control register. Default 17.5 mA (typ.)
28	LED3 CURRENT CONTROL	[7:0]	R/W	10101111	CURRENT LED3 output current control register. Default 17.5 mA (typ.)
29	LED4 CURRENT CONTROL	[7:0]	R/W	10101111	CURRENT LED4 output current control register. Default 17.5 mA (typ.)
2A	LED5 CURRENT CONTROL	[7:0]	R/W	10101111	CURRENT LED5 output current control register. Default 17.5 mA (typ.)
2B	LED6 CURRENT CONTROL	[7:0]	R/W	10101111	CURRENT LED6 output current control register. Default 17.5 mA (typ.)
2C	LED7 CURRENT CONTROL	[7:0]	R/W	10101111	CURRENT LED7 output current control register. Default 17.5 mA (typ.)
0x2D	LED8 CURRENT CONTROL	[7:0]	R/W	10101111	CURRENT LED8 output current control register. Default 17.5 mA (typ.)
0x2E	LED9 CURRENT CONTROL	[7:0]	R/W	10101111	CURRENT LED9 output current control register. Default 17.5 mA (typ.)
2F to 35		[7:0]			reserved

Table 7. Description of Registers

Hex Address	Register Name	Bit(s)	Type	Default Value After Reset	Description
36	MISC	[7]	R/W	0xxxxxxx	VARIABLE_D_SEL Variable LED source selection
		[6]		x1xxxxxx	EN_AUTO_INCR Serial bus address auto increment enable
		[5]		xx0xxxxx	POWERSAVE_EN Powersave mode enable
		[4:3]		xxx00xxx	CP_MODE Charge pump gain selection
		[2]		xxxxx0xx	PWM_PS_EN PWM cycle powersave enable
		[1]		xxxxxx0x	CLK_DET_EN External clock detection
		[0]		xxxxxxx0	INT_CLK_EN Clock source selection
37	ENGINE1 PC	[6:0]	R/W	x0000000	PC Program counter for engine 1
38	ENGINE2 PC	[6:0]	R/W	x0000000	PC Program counter for engine 2
39	ENGINE3 PC	[6:0]	R/W	x0000000	PC Program counter for engine 3
3A	STATUS / INTERRUPT	[7]	R	0xxxxxxx	LEDTEST_MEAS_DONE Indicates when the LED test measurement is done.
		[6]		x1xxxxxx	MASK_BUSY Mask bit for interrupts generated by STARTUP_BUSY or ENGINE_BUSY
		[5]		xx0xxxxx	STARTUP_BUSY This bit indicates that the start-up sequence is running
		[4]		xxx0xxxx	ENGINE_BUSY This bit indicates that a program execution engine is clearing internal registers
		[3]		xxxx0xxx	EXT_CLK_USED Indicates when external clock signal is in use
		[2]		xxxxx0xx	ENG1_INT Interrupt bit for program execution engine 1
		[1]		xxxxxx0x	ENG2_INT Interrupt bit for program execution engine 2
		[0]		xxxxxxx0	ENG3_INT Interrupt bit for program execution engine 3
3B	GPO	[2]	R/W	xxxxx0xx	INT_CONF INT pin can be configured to function as a GPO with this bit
		[1]		xxxxxx0x	GPO pin control
		[0]		xxxxxxx0	INT_GPO GPO pin control for INT pin (when INT_CONF is set "1")
3C	VARIABLE	[7:0]	R/W	00000000	VARIABLE Global 8-bit variable

Table 7. Description of Registers

Hex Address	Register Name	Bit(s)	Type	Default Value After Reset	Description
3D	RESET	[7:0]	R/W	00000011	RESET Writing 11111111 into this register resets the AS3661
3E	TEMP ADC CONTROL	[7]	R	0xxxxxxx	TEMP_MEAS_BUSY Indicates when temperature measurement is active
		[2]	R/W	xxxxx0xx	EN_TEMP_SENSOR Reads the internal temperature sensor once
		[1]		xxxxxx0x	CONTINUOUS_CONV Continuous temperature measurement selection
		[0]		xxxxxxx0	SEL_EXT_TEMP Internal/external temperature sensor selection
3F	TEMPERATURE READ	[7:0]	R	00011001	TEMPERATURE Bits for temperature information
40	TEMPERATURE WRITE	[7:0]	R/W	00000000	TEMPERATURE Bits for temperature information
41	LED TEST CONTROL	[7]	R/W	0xxxxxxx	EN_LED_TEST_ADC
		[6]		x0xxxxxx	EN_LED_TEST_INT
		[5]		xx0xxxxx	CONTINUOUS_CONV Continuous LED test measurement selection
		[4:0]		xxx00000	LED_TEST_CTRL Control bits for LED test
42	LED TEST ADC	[7:0]	R	N/A	LED_TEST_ADC LED test result
43		[7:0]			reserved
44		[7:0]			reserved
45	ENGINE1 VARIABLE A	[7:0]	R	00000000	VARIABLE FOR ENGINE1
46	ENGINE2 VARIABLE A	[7:0]	R	00000000	VARIABLE FOR ENGINE2
47	ENGINE3 VARIABLE A	[7:0]	R	00000000	VARIABLE FOR ENGINE3
48	MASTER FADER1	[7:0]	R/W	00000000	MASTER FADER 1
49	MASTER FADER2	[7:0]	R/W	00000000	MASTER FADER 2
4A	MASTER FADER3	[7:0]	R/W	00000000	MASTER FADER 3
4B		[7:0]			reserved
4C	ENG1 PROG START ADDR	[6:0]	R/W	x0000000	Engine 1 program start address
4D	ENG2 PROG START ADDR	[6:0]	R/W	x0001000	Engine 2 program start address
4E	ENG3 PROG START ADDR	[6:0]	R/W	x0010000	Engine 3 program start address
4F	PROG MEM PAGE SEL	[2:0]	R/W	xxxxx000	PAGE_SEL

Table 7. Description of Registers

Hex Address	Register Name	Bit(s)	Type	Default Value After Reset	Description
50	PROGRAM MEMORY 00H/10H/20H/30H/ 40H/50H	[15:8]	R/W	00000000	<p style="text-align: center;"><b>CMD</b></p> <p>Every Instruction is 16-bit width. The AS3661 can store 96 instructions. Each instruction consists of 16 bits. Because one register has only 8 bits, one instruction requires two register addresses. In order to reduce program load time the AS3661 supports address auto-incrementation. Register address is incremented after each 8 data bits. Thus the whole program memory page can be written in one serial bus write sequence.</p>
51		[7:0]		00000000	
52	PROGRAM MEMORY 01H/11H/21H/31H/ 41H/51H	[15:8]	R/W	00000000	
53		[7:0]		00000000	
54	PROGRAM MEMORY 02H/12H/22H/32H/ 42H/52H	[15:8]	R/W	00000000	
55		[7:0]		00000000	
56	PROGRAM MEMORY 03H/13H/23H/33H/ 43H/53H	[15:8]	R/W	00000000	
57		[7:0]		00000000	

Table 7. Description of Registers

Hex Address	Register Name	Bit(s)	Type	Default Value After Reset	Description
58	PROGRAM MEMORY	[15:8]	R/W	00000000	<p><b>CMD</b></p> <p>Every Instruction is 16-bit width. The AS3661 can store 96 instructions. Each instruction consists of 16 bits. Because one register has only 8 bits, one instruction requires two register addresses. In order to reduce program load time the AS3661 supports address auto-incrementation. Register address is incremented after each 8 data bits. Thus the whole program memory page can be written in one serial bus write sequence.</p>
59	04H/14H/24H/34H/44H/54H	[7:0]		00000000	
5A	PROGRAM MEMORY	[15:8]	R/W	00000000	
5B	05H/15H/25H/35H/45H/55H	[7:0]		00000000	
5C	PROGRAM MEMORY	[15:8]	R/W	00000000	
5D	06H/16H/26H/36H/46H/56H	[7:0]		00000000	
5E	PROGRAM MEMORY	[15:8]	R/W	00000000	
5F	07H/17H/27H/37H/47H/57H	[7:0]		00000000	
60	PROGRAM MEMORY	[15:8]	R/W	00000000	
61	08H/18H/28H/38H/48H/58H	[7:0]		00000000	
62	PROGRAM MEMORY	[15:8]	R/W	00000000	
63	09H/19H/29H/39H/49H/59H	[7:0]		00000000	
64	PROGRAM MEMORY	[15:8]	R/W	00000000	
65	0AH/1AH/2AH/3AH/4AH/5AH	[7:0]		00000000	
66	PROGRAM MEMORY	[15:8]	R/W	00000000	
67	0BH/1BH/2BH/3BH/4BH/5BH	[7:0]		00000000	
68	PROGRAM MEMORY	[15:8]	R/W	00000000	
69	0CH/1CH/2CH/3CH/4CH/5CH	[7:0]		00000000	
6A	PROGRAM MEMORY	[15:8]	R/W	00000000	
6B	0DH/1DH/2DH/36D/46D/5DH	[7:0]		00000000	
6C	PROGRAM MEMORY	[15:8]	R/W	00000000	
6D	0EH/1EH/2EH/3EH/4EH/5EH	[7:0]		00000000	
6E	PROGRAM MEMORY	[15:8]	R/W	00000000	
6F	0FH/1FH/2FH/3FH/4FH/5FH	[7:0]		00000000	
70	ENG1 MAPPING MSB	[7]	R	0xxxxxxx	<b>GPO</b> Engine 1 mapping information, GPO pin
		[0]		xxxxxxx0	<b>D9</b> Engine 1 mapping information, D9 output



Table 7. Description of Registers

Hex Address	Register Name	Bit(s)	Type	Default Value After Reset	Description
71	ENG1 MAPPING LSB	[7]	R	0xxxxxxx	LED8 Engine 1 mapping information, LED8 output
		[6]		x0xxxxxx	LED7 Engine 1 mapping information, LED7 output
		[5]		xx0xxxxx	LED6 Engine 1 mapping information, LED6 output
		[4]		xxx0xxxx	LED5 Engine 1 mapping information, LED5 output
		[3]		xxxx0xxx	LED4 Engine 1 mapping information, LED4 output
		[2]		xxxxx0xx	LED3 Engine 1 mapping information, LED3 output
		[1]		xxxxxx0x	LED2 Engine 1 mapping information, LED2 output
		[0]		xxxxxxx0	LED1 Engine 1 mapping information, LED1 output
72	ENG2 MAPPING MSB	[7]	R	0xxxxxxx	GPO Engine 2 mapping information, GPO pin
		[0]		xxxxxxx0	LED9 Engine 2 mapping information, D9 output
73	ENG2 MAPPING LSB	[7]	R	0xxxxxxx	LED8 Engine 2 mapping information, LED8 output
		[6]		x0xxxxxx	LED7 Engine 2 mapping information, LED7 output
		[5]		xx0xxxxx	LED6 Engine 2 mapping information, LED6 output
		[4]		xxx0xxxx	LED5 Engine 2 mapping information, LED5 output
		[3]		xxxx0xxx	LED4 Engine 2 mapping information, LED4 output
		[2]		xxxxx0xx	LED3 Engine 2 mapping information, LED3 output
		[1]		xxxxxx0x	LED2 Engine 2 mapping information, LED2 output
		[0]		xxxxxxx0	LED1 Engine 2 mapping information, LED1 output
74	ENG3 MAPPING MSB	[7]	R	0xxxxxxx	GPO Engine 3 mapping information, GPO pin
		[0]		xxxxxxx0	LED9 Engine 3 mapping information, LED9 output

Table 7. Description of Registers

Hex Address	Register Name	Bit(s)	Type	Default Value After Reset	Description	
75	ENG3 MAPPING LSB	[7]	R	0xxxxxxx	LED8 Engine 3 mapping information, LED8 output	
		[6]		x0xxxxxx	LED7 Engine 3 mapping information, LED7 output	
		[5]		xx0xxxxx	LED6 Engine 3 mapping information, LED6 output	
		[4]		xxx0xxxx	LED5 Engine 3 mapping information, LED5 output	
		[3]		xxxx0xxx	LED4 Engine 3 mapping information, LED4 output	
		[2]		xxxxx0xx	LED3 Engine 3 mapping information, LED3 output	
		[1]		xxxxxx0x	LED2 Engine 3 mapping information, LED2 output	
		[0]		xxxxxxx0	LED1 Engine 3 mapping information, LED1 output	
76	GAIN CHANGE CTRL	[7:6]	R/W	00xxxxxx	TRESHOLD Threshold voltage (typ.)	
					00	400mV
					01	300mV
					10	200mV
					11	100mV
		[5]	R/W	xx0xxxxx	ADAPTIVE_TRESH_EN Activates adaptive threshold.	
		[4:3]	R/W	xxx00xxx	TIMER	
					00	5ms
					01	10ms
					10	50ms
				11	Infinite	
		[2]	R/W	xxxxx0xx	FORCE_1x Activates 1.5x to 1x timer	

## 8.10 Control Register Details

### 8.10.1 ENABLE/ ENGINE CONTROL1

This register controls the startup of the chip and the program execution modes for each program execution engine.

Table 8. ENABLE / ENGINE CNTR 1 Register

Register: 0x00		ENABLE / ENGINE CNTR1		
Bit	Bit Name	Default	Access	Bit Description
6	CHIP_EN	0	R/W	<p><b>0: Standby mode is entered. Still, control registers can be written or read, excluding bits [5:0] in reg 00 (this register), registers 16h to 1E (LED PWM registers) and 37h to 39h (program counters).</b></p> <p>1: internal startup sequence powers up all the needed internal blocks and the device enters normal mode.</p>
5:4	ENGINE1_EXEC	00	R/W	<p>The engine 1 program execution control register bits define how the program is executed. Program start address can be programmed to program counter (PC) register 0x37.</p> <p><b>00: Hold causes the execution engine to finish the current instruction and then stop. Program counter (PC) can be read or written only in this mode.</b></p> <p>01: Execute the instruction at the location pointed by the PC, increment the PC by one and then reset ENG1_EXEC bits to 00 (i.e. enter hold).</p> <p>10: Start program execution from the location pointed by the PC. This mode is also called "Free Run" mode.</p> <p>11: Execute the instruction pointed by the current PC value and reset ENG1_EXEC to 00 (i.e. enter hold). The difference between step and execute once is that execute once does not increment the PC.</p>

Table 8. ENABLE / ENGINE CNTR 1 Register

Register: 0x00		ENABLE / ENGINE CNTR1		
Bit	Bit Name	Default	Access	Bit Description
3:2	ENGINE2_EXEC	00	R/W	<p>The engine 2 program execution control register bits define how the program is executed. Program start address can be programmed to program counter (PC) register 0x38.</p> <p><b>00: Hold causes the execution engine to finish the current instruction and then stop. Program counter (PC) can be read or written only in this mode.</b></p> <p>01: Execute the instruction at the location pointed by the PC, increment the PC by one and then reset ENG2_EXEC bits to 00 (i.e. enter hold).</p> <p>10: Start program execution from the location pointed by the PC. This mode is also called "Free Run" mode.</p> <p>11: Execute the instruction pointed by the current PC value and reset ENG2_EXEC to 00 (i.e. enter hold). The difference between step and execute once is that execute once does not increment the PC.</p>
1:0	ENGINE3_EXEC	00	R/W	<p>The engine 3 program execution control register bits define how the program is executed. Program start address can be programmed to program counter (PC) register 0x39.</p> <p><b>00: Hold causes the execution engine to finish the current instruction and then stop. Program counter (PC) can be read or written only in this mode.</b></p> <p>01: Executes the instruction at the location pointed by the PC, increment the PC by one and then reset ENG3_EXEC bits to 00 (i.e. enter hold).</p> <p>10: Start program execution from the location pointed by the PC. This mode is also called "Free Run" mode.</p> <p>11: Execute the instruction pointed by the current PC value and reset ENG3_EXEC to 00 (i.e. enter hold). The difference between step and execute once is that execute once does not increment the PC.</p>

### 8.10.2 ENGINE CNTRL2

The AS3661 supports up to four different operation modes which are defined in these registers.

**Disabled:** Engines can be configured to disabled mode each one separately.

**Load program:** Writing to program memory is allowed only when the engine is in load program operation mode and engine busy bit (reg 3A) is not set. Serial bus master should check the busy bit before writing to program memory. All the three engines are in hold while one or more engines are in load program mode. PWM values are frozen, also. Program execution continues when all the engines are out of load program mode. Load program mode resets the program counter of the respective engine. Load program mode can be entered from the disabled mode only. Entering load program mode from the run program mode is not allowed.

**Run Program:** Run program mode executes the instructions stored in the program memory. Execution register (ENG1\_EXEC etc.) bits define how the program is executed (hold, step, free run or execute once). Program start address can be programmed to the Program Counter (PC) register. The Program Counter is reset to zero when the PC's upper limit value is reached.

**Halt:** Instruction execution aborts immediately and engine operation halts.

Table 9. ENGINE\_CNTRL2 Register

Register: 0x01		ENGINE_CNTRL2		
Bit	Bit Name	Default	Access	Bit Description
5:4	ENGINE1_MODE	00	R/W	<b>00: Disabled</b> 01: Load program to SRAM, reset engine 1 PC 10: Run program as defined by ENGINE1_EXEC bits 11: Halts the engine
3:2	ENGINE2_MODE	00	R/W	<b>00: Disabled</b> 01: Load program to SRAM, reset engine 2 PC 10: Run program as defined by ENGINE2_EXEC bits 11: Halts the engine
1:0	ENGINE3_MODE	00	R/W	<b>00: Disabled</b> 01: Load program to SRAM, reset engine 3 PC 10: Run program as defined by ENGINE3_EXEC bits 11: Halts the engine

### 8.10.3 OUTPUT\_DIRECT/RATIOMETRIC\_MSB and LSB

A particular feature of the AS3661 is the ratiometric up/down dimming of the RGB-LEDs. In other words, the LED driver PWM output will vary in a ratiometric manner. By a ratiometric approach the emitted color of an RGB-LED remains the same regardless of the initial magnitudes of the R/G/B PWM outputs. For example, if the PWM output of the red LED output is doubled, the output of green LED is doubled also.

Table 10. OUTPUT\_DIRECT / RATIOMETRIC\_MSB Register

Register: 0x02		OUTPUT_DIRECT/RATIOMETRIC_MSB		
Bit	Bit Name	Default	Access	Bit Description
0	LED9_RATIO_EN	0	R/W	<b>0: Disables ratiometric dimming for LED9 output.</b> 1: enables ratiometric dimming for LED9 output.

Table 11. OUTPUT\_DIRECT / RATIOMETRIC\_LSB Register

Register: 0x03		OUTPUT_DIRECT/RATIOMETRIC_LSB		
Bit	Bit Name	Default	Access	Bit Description
7	LED8_RATIO_EN	0	R/W	<b>0: Disables ratiometric dimming for LED8 output.</b> 1: enables ratiometric dimming for LED9 output.
6	LED7_RATIO_EN	0	R/W	<b>0: Disables ratiometric dimming for LED7 output.</b> 1: enables ratiometric dimming for LED9 output.
5	LED6_RATIO_EN	0	R/W	<b>0: Disables ratiometric dimming for LED6 output.</b> 1: enables ratiometric dimming for LED9 output.
4	LED5_RATIO_EN	0	R/W	<b>0: Disables ratiometric dimming for LED5 output.</b> 1: enables ratiometric dimming for LED9 output.
3	LED4_RATIO_EN	0	R/W	<b>0: Disables ratiometric dimming for LED4 output.</b> 1: enables ratiometric dimming for LED9 output.
2	LED3_RATIO_EN	0	R/W	<b>0: Disables ratiometric dimming for LED3 output.</b> 1: enables ratiometric dimming for LED9 output.

Table 11. OUTPUT DIRECT / RATIOMETRIC LSB Register

Register: 0x03		OUTPUT DIRECT/RATIOMETRIC LSB		
Bit	Bit Name	Default	Access	Bit Description
1	LED2_RATIO_EN	0	R/W	<b>0: Disables ratiometric dimming for LED2 output.</b> 1: enables ratiometric dimming for LED9 output.
0	LED1_RATIO_EN	0	R/W	<b>0: Disables ratiometric dimming for LED1 output.</b> 1: enables ratiometric dimming for LED9 output.

#### 8.10.4 OUTPUT ON/OFF CONTROL MSB and LSB

The following two registers allow the user to switch all nine current sources independently from each other on and off. Please mind that this selection will be overridden if a current source is selected by one of the program execution engines.

Table 12. OUTPUT ON/OFF CONTROL MSB Register

Register: 0x04		OUTPUT ON/OFF CONTROL MSB		
Bit	Bit Name	Default	Access	Bit Description
0	LED9_ON	0	R/W	<b>0: LED9 output off.</b> 1: LED9 output on.

Table 13. OUTPUT ON/OFF CONTROL LSB Register

Register: 0x05		OUTPUT ON/OFF CONTROL LSB		
Bit	Bit Name	Default	Access	Bit Description
7	LED8_ON	0	R/W	<b>0: LED8 output off.</b> 1: LED8 output on.
6	LED7_ON	0	R/W	<b>0: LED7 output off.</b> 1: LED7 output on.
5	LED6_ON	0	R/W	<b>0: LED6 output off.</b> 1: LED6 output on.
4	LED5_ON	0	R/W	<b>0: LED5 output off.</b> 1: LED5 output on.
3	LED4_ON	0	R/W	<b>0: LED4 output off.</b> 1: LED4 output on.
2	LED3_ON	0	R/W	<b>0: LED3 output off.</b> 1: LED3 output on.
1	LED2_ON	0	R/W	<b>0: LED2 output off.</b> 1: LED2 output on.
0	LED1_ON	0	R/W	<b>0: LED1 output off.</b> 1: LED1 output on.

### 8.10.5 LEDx Control

These registers are used to assign the any current source output to the MASTER FADER group 1, 2, or 3, or none of them. Also, the registers set the slope of the current sources output temperature compensation line and selects between linear and logarithmic PWM brightness adjustment. By using logarithmic PWM-scale the visual effect looks like linear. When the logarithmic adjustment is enabled, the chip handles internally PWM values with 12-bit resolution. This allows very fine-grained PWM control at low PWM duty cycles. If a MASTER FADER is selected for an output, the duty cycle on the output will be LED1 PWM register value (address 0x16) multiplied with the value in the MASTER FADER register.

Besides the LED mapping and linear or logarithmic selection it is also possible to do a temperature compensation for each output separately. The PWM duty cycle at temperature T (in centigrade) can be obtained as follows:  $PWM_F = [PWM_s - (25 - T) * slope * PWM_s] / 2$ , where  $PWM_F$  is the final duty cycle at temperature T,  $PWM_s$  is the set PWM duty cycle (PWM duty cycle is set in registers 16H to 1EH) and the value of the correction factor is obtained from [Table 8](#).

For example, if the set PWM duty cycle in register 16H is 90%, temperature T is -10°C and the chosen slope is +1.5 1/°C, the final duty cycle  $PWM_F$  for LED1 output will be  $[90\% - (25\% - (-10\%)) * 1.5 \text{ 1/}^\circ\text{C} * 90\%] / 2 = [90\% - 35\% * 1.5 * 90\%] / 2 = 21.4\%$ . Default setting 00000 means that the temperature compensation is non-active and the PWM output (0 to 100%) is set solely by PWM registers LED1 PWM to LED9 PWM.

Table 14. LED1 CONTROL Register

Register: 0x06		LED1 CONTROL		
Bit	Bit Name	Default	Access	Bit Description
7:6	LED1_MAPPING	00	R/W	This register defines the mapping of LED1 output to the master faders. The faders can either be used for dimming several LEDs in parallel or for ratiometric control of the output. <b>00: no master fader selected</b> 01: MASTER FADER 1 controls LED1 output 10: MASTER FADER 2 controls LED1 output 11: MASTER FADER 3 controls LED1 output
5	LED1_LOG_EN	0	R/W	This bit is effective for both, program execution engine and direct PWM control. <b>0: linear adjustment.</b> 1: logarithmic adjustment.
4:0	LED1_TEMP_COMP	0 0000	R/W	The reference temperature is +25°C (i.e. the temperature at which all slope settings have no effect) and the temperature coefficient (slope) can be set in 0.1 1/°C steps to any value between -1.5 1/°C and +1.5 1/°C, with a default to 0.0 1/°C 11111: -1.5 1/°C 11110: -1.4 1/°C ... <b>00000: temperature compensation not activated</b> ... 01110: +1.4 1/°C 01111: +1.5 1/°C

Table 15. LED2 CONTROL Register

Register: 0x07		LED2 CONTROL		
Bit	Bit Name	Default	Access	Bit Description
7:6	LED2_MAPPING	00	R/W	<p>This register defines the mapping of LED2 output to the master faders. The faders can either be used for dimming several LEDs in parallel or for ratiometric control of the output.</p> <p><b>00: no master fader selected</b>            01: MASTER FADER 1 controls LED2 output            10: MASTER FADER 2 controls LED2 output            11: MASTER FADER 3 controls LED2 output</p>
5	LED2_LOG_EN	0	R/W	<p>This bit is effective for both, program execution engine and direct PWM control.</p> <p><b>0: linear adjustment.</b>            1: logarithmic adjustment.</p>
4:0	LED2_TEMP_COMP	0 0000	R/W	<p>The reference temperature is +25°C (i.e. the temperature at which all slope settings have no effect) and the temperature coefficient (slope) can be set in 0.1 1/°C steps to any value between -1.5 1/°C and +1.5 1/°C, with a default to 0.0 1/°C</p> <p>11111: -1.5 1/°C            11110: -1.4 1/°C            ...  <b>00000: temperature compensation not activated</b>            ...            01110: +1.4 1/°C            01111: +1.5 1/°C</p>

Table 16. LED3 CONTROL Register

Register: 0x08		LED3 CONTROL		
Bit	Bit Name	Default	Access	Bit Description
7:6	LED3_MAPPING	00	R/W	<p>This register defines the mapping of LED3 output to the master faders. The faders can either be used for dimming several LEDs in parallel or for ratiometric control of the output.</p> <p><b>00: no master fader selected</b>            01: MASTER FADER 1 controls LED3 output            10: MASTER FADER 2 controls LED3 output            11: MASTER FADER 3 controls LED3 output</p>



Table 16. LED3 CONTROL Register

Register: 0x08		LED3 CONTROL		
Bit	Bit Name	Default	Access	Bit Description
5	LED3_LOG_EN	0	R/W	This bit is effective for both, program execution engine and direct PWM control. <b>0: linear adjustment.</b> 1: logarithmic adjustment.
4:0	LED3_TEMP_COMP	0 0000	R/W	The reference temperature is +25°C (i.e. the temperature at which all slope settings have no effect) and the temperature coefficient (slope) can be set in 0.1 1/°C steps to any value between -1.5 1/°C and +1.5 1/°C, with a default to 0.0 1/°C 11111: -1.5 1/°C 11110: -1.4 1/°C ... <b>00000: temperature compensation not activated</b> ... 01110: +1.4 1/°C 01111: +1.5 1/°C

Table 17. LED4 CONTROL Register

Register: 0x09		LED1 CONTROL		
Bit	Bit Name	Default	Access	Bit Description
7:6	LED4_MAPPING	00	R/W	This register defines the mapping of LED4 output to the master faders. The faders can either be used for dimming several LEDs in parallel or for ratiometric control of the output. <b>00: no master fader selected</b> 01: MASTER FADER 1 controls LED4 output 10: MASTER FADER 2 controls LED4 output 11: MASTER FADER 3 controls LED4 output
5	LED4_LOG_EN	0	R/W	This bit is effective for both, program execution engine and direct PWM control. <b>0: linear adjustment.</b> 1: logarithmic adjustment.
4:0	LED4_TEMP_COMP	0 0000	R/W	The reference temperature is +25°C (i.e. the temperature at which all slope settings have no effect) and the temperature coefficient (slope) can be set in 0.1 1/°C steps to any value between -1.5 1/°C and +1.5 1/°C, with a default to 0.0 1/°C 11111: -1.5 1/°C 11110: -1.4 1/°C ... <b>00000: temperature compensation not activated</b> ... 01110: +1.4 1/°C 01111: +1.5 1/°C

Table 18. LED5 CONTROL Register

Register: 0x0A		LED1 CONTROL		
Bit	Bit Name	Default	Access	Bit Description
7:6	LED5_MAPPING	00	R/W	<p>This register defines the mapping of LED5 output to the master faders. The faders can either be used for dimming several LEDs in parallel or for ratiometric control of the output.</p> <p><b>00: no master fader selected</b>            01: MASTER FADER 1 controls LED5 output            10: MASTER FADER 2 controls LED5 output            11: MASTER FADER 3 controls LED5 output</p>
5	LED5_LOG_EN	0	R/W	<p>This bit is effective for both, program execution engine and direct PWM control.</p> <p><b>0: linear adjustment.</b>            1: logarithmic adjustment.</p>
4:0	LED5_TEMP_COMP	0 0000	R/W	<p>The reference temperature is +25°C (i.e. the temperature at which all slope settings have no effect) and the temperature coefficient (slope) can be set in 0.1 1/°C steps to any value between -1.5 1/°C and +1.5 1/°C, with a default to 0.0 1/°C</p> <p>11111: -1.5 1/°C            11110: -1.4 1/°C            ...  <b>00000: temperature compensation not activated</b>            ...            01110: +1.4 1/°C            01111: +1.5 1/°C</p>

Table 19. LED6 CONTROL Register

Register: 0x0B		LED6 CONTROL		
Bit	Bit Name	Default	Access	Bit Description
7:6	LED6_MAPPING	00	R/W	<p>This register defines the mapping of LED6 output to the master faders. The faders can either be used for dimming several LEDs in parallel or for ratiometric control of the output.</p> <p><b>00: no master fader selected</b>            01: MASTER FADER 1 controls LED6 output            10: MASTER FADER 2 controls LED6 output            11: MASTER FADER 3 controls LED6 output</p>

Table 19. LED6 CONTROL Register

Register: 0x0B		LED6 CONTROL		
Bit	Bit Name	Default	Access	Bit Description
5	LED6_LOG_EN	0	R/W	This bit is effective for both, program execution engine and direct PWM control. <b>0: linear adjustment.</b> 1: logarithmic adjustment.
4:0	LED6_TEMP_COMP	0 0000	R/W	The reference temperature is +25°C (i.e. the temperature at which all slope settings have no effect) and the temperature coefficient (slope) can be set in 0.1 1/°C steps to any value between -1.5 1/°C and +1.5 1/°C, with a default to 0.0 1/°C 11111: -1.5 1/°C 11110: -1.4 1/°C ... <b>00000: temperature compensation not activated</b> ... 01110: +1.4 1/°C 01111: +1.5 1/°C

Table 20. LED7 CONTROL Register

Register: 0x0C		LED7 CONTROL		
Bit	Bit Name	Default	Access	Bit Description
7:6	LED7_MAPPING	00	R/W	This register defines the mapping of LED7 output to the master faders. The faders can either be used for dimming several LEDs in parallel or for ratiometric control of the output. <b>00: no master fader selected</b> 01: MASTER FADER 1 controls LED7 output 10: MASTER FADER 2 controls LED7 output 11: MASTER FADER 3 controls LED7 output
5	LED7_LOG_EN	0	R/W	This bit is effective for both, program execution engine and direct PWM control. <b>0: linear adjustment.</b> 1: logarithmic adjustment.
4:0	LED7_TEMP_COMP	0 0000	R/W	The reference temperature is +25°C (i.e. the temperature at which all slope settings have no effect) and the temperature coefficient (slope) can be set in 0.1 1/°C steps to any value between -1.5 1/°C and +1.5 1/°C, with a default to 0.0 1/°C 11111: -1.5 1/°C 11110: -1.4 1/°C ... <b>00000: temperature compensation not activated</b> ... 01110: +1.4 1/°C 01111: +1.5 1/°C

Table 21. LED8 CONTROL Register

Register: 0x0D		LED8 CONTROL		
Bit	Bit Name	Default	Access	Bit Description
7:6	LED8_MAPPING	00	R/W	<p>This register defines the mapping of LED8 output to the master faders. The faders can either be used for dimming several LEDs in parallel or for ratiometric control of the output.</p> <p><b>00: no master fader selected</b>            01: MASTER FADER 1 controls LED8 output            10: MASTER FADER 2 controls LED8 output            11: MASTER FADER 3 controls LED8 output</p>
5	LED8_LOG_EN	0	R/W	<p>This bit is effective for both, program execution engine and direct PWM control.</p> <p><b>0: linear adjustment.</b>            1: logarithmic adjustment.</p>
4:0	LED8_TEMP_COMP	0 0000	R/W	<p>The reference temperature is +25°C (i.e. the temperature at which all slope settings have no effect) and the temperature coefficient (slope) can be set in 0.1 1/°C steps to any value between -1.5 1/°C and +1.5 1/°C, with a default to 0.0 1/°C</p> <p>11111: -1.5 1/°C            11110: -1.4 1/°C            ...  <b>00000: temperature compensation not activated</b>            ...            01110: +1.4 1/°C            01111: +1.5 1/°C</p>

Table 22. LED9 CONTROL Register

Register: 0x0E		LED9 CONTROL		
Bit	Bit Name	Default	Access	Bit Description
7:6	LED9_MAPPING	00	R/W	<p>This register defines the mapping of LED9 output to the master faders. The faders can either be used for dimming several LEDs in parallel or for ratiometric control of the output.</p> <p><b>00: no master fader selected</b>            01: MASTER FADER 1 controls LED9 output            10: MASTER FADER 2 controls LED9 output            11: MASTER FADER 3 controls LED9 output</p>

Table 22. LED9 CONTROL Register

Register: 0x0E		LED9 CONTROL		
Bit	Bit Name	Default	Access	Bit Description
5	LED9_LOG_EN	0	R/W	This bit is effective for both, program execution engine and direct PWM control. <b>0: linear adjustment.</b> 1: logarithmic adjustment.
4:0	LED8_TEMP_COMP	0 0000	R/W	The reference temperature is +25°C (i.e. the temperature at which all slope settings have no effect) and the temperature coefficient (slope) can be set in 0.1 1/°C steps to any value between -1.5 1/°C and +1.5 1/°C, with a default to 0.0 1/°C 11111: -1.5 1/°C 11110: -1.4 1/°C ... <b>00000: temperature compensation not activated</b> ... 01110: +1.4 1/°C 01111: +1.5 1/°C

### 8.10.6 LEDx PWM

This is the PWM duty cycle control for LED1 to LED9 output. The PWM registers are effective during direct control operation. Direct PWM control is active after power up by default.

**Note:** Serial bus address auto increment is not supported for register addresses from 16 to 1E.

**Note:** If the temperature compensation is active, the maximum PWM duty cycle is 50% at +25°C. This is required to allow enough headroom for temperature compensation over the temperature range -40 °C to 90°C.

Table 23. LED1 PWM Register

Register: 0x16		LED1 PWM		
Bit	Bit Name	Default	Access	Bit Description
7:0	LED1_PWM	0000 0000	R/W	This register controls the duty cycle of LED1 PWM output. <b>0000 0000: 0% Duty Cycle</b> 0000 0001: 0.3921% Duty Cycle 0000 0010: 0.7843% Duty Cycle 0000 0011: 1.1765% Duty Cycle .... 1111 1111: 100% Duty Cycle

Table 24. LED2 PWM Register

Register: 0x17		LED2 PWM		
Bit	Bit Name	Default	Access	Bit Description
7:0	LED2_PWM	0000 0000	R/W	This register controls the duty cycle of LED2 PWM output. <b>0000 0000: 0% Duty Cycle</b> 0000 0001: 0.3921% Duty Cycle 0000 0010: 0.7843% Duty Cycle 0000 0011: 1.1765% Duty Cycle .... 1111 1111: 100% Duty Cycle

Table 25. LED3 PWM Register

Register: 0x18		LED3 PWM		
Bit	Bit Name	Default	Access	Bit Description
7:0	LED3_PWM	0000 0000	R/W	This register controls the duty cycle of LED3 PWM output. <b>0000 0000: 0% Duty Cycle</b> 0000 0001: 0.3921% Duty Cycle 0000 0010: 0.7843% Duty Cycle 0000 0011: 1.1765% Duty Cycle .... 1111 1111: 100% Duty Cycle

Table 26. LED4 PWM Register

Register: 0x19		LED4 PWM		
Bit	Bit Name	Default	Access	Bit Description
7:0	LED4_PWM	0000 0000	R/W	This register controls the duty cycle of LED4 PWM output. <b>0000 0000: 0% Duty Cycle</b> 0000 0001: 0.3921% Duty Cycle 0000 0010: 0.7843% Duty Cycle 0000 0011: 1.1765% Duty Cycle .... 1111 1111: 100% Duty Cycle

Table 27. LED5 PWM Register

Register: 0x1A		LED5 PWM		
Bit	Bit Name	Default	Access	Bit Description
7:0	LED5_PWM	0000 0000	R/W	This register controls the duty cycle of LED5 PWM output. <b>0000 0000: 0% Duty Cycle</b> 0000 0001: 0.3921% Duty Cycle 0000 0010: 0.7843% Duty Cycle 0000 0011: 1.1765% Duty Cycle .... 1111 1111: 100% Duty Cycle

Table 28. LED6 PWM Register

Register: 0x1B		LED6 PWM		
Bit	Bit Name	Default	Access	Bit Description
7:0	LED6_PWM	0000 0000	R/W	This register controls the duty cycle of LED6 PWM output. <b>0000 0000: 0% Duty Cycle</b> 0000 0001: 0.3921% Duty Cycle 0000 0010: 0.7843% Duty Cycle 0000 0011: 1.1765% Duty Cycle .... 1111 1111: 100% Duty Cycle

Table 29. LED7 PWM Register

Register: 0x1C		LED7 PWM		
Bit	Bit Name	Default	Access	Bit Description
7:0	LED7_PWM	0000 0000	R/W	This register controls the duty cycle of LED7 PWM output. <b>0000 0000: 0% Duty Cycle</b> 0000 0001: 0.3921% Duty Cycle 0000 0010: 0.7843% Duty Cycle 0000 0011: 1.1765% Duty Cycle .... 1111 1111: 100% Duty Cycle

Table 30. LED8 PWM Register

Register: 0x1D		LED8 PWM		
Bit	Bit Name	Default	Access	Bit Description
7:0	LED8_PWM	0000 0000	R/W	This register controls the duty cycle of LED8 PWM output. <b>0000 0000: 0% Duty Cycle</b> 0000 0001: 0.3921% Duty Cycle 0000 0010: 0.7843% Duty Cycle 0000 0011: 1.1765% Duty Cycle .... 1111 1111: 100% Duty Cycle

Table 31. LED9 PWM Register

Register: 0x1E		LED9 PWM		
Bit	Bit Name	Default	Access	Bit Description
7:0	LED9_PWM	0000 0000	R/W	This register controls the duty cycle of LED9 PWM output. <b>0000 0000: 0% Duty Cycle</b> 0000 0001: 0.3921% Duty Cycle 0000 0010: 0.7843% Duty Cycle 0000 0011: 1.1765% Duty Cycle .... 1111 1111: 100% Duty Cycle

### 8.10.7 LEDx CURRENT CONTROL

With the following register it is possible to control the output current of each current source separately. The resolution of the current sources is 8-bit which gives a step size is 100  $\mu$ A with a maximum output current of 25.5mA per current source.

Table 32. LED1 CURRENT CONTROL Register

Register: 0x26		LED1 CURRENT CONTROL		
Bit	Bit Name	Default	Access	Bit Description
7:0	LED1_CURRENT	1010 1111	R/W	This register controls the output current of current source LED1 in 100 $\mu$ A steps from 0 $\mu$ A up to 25.5mA. 0000 0000: 0mA 0000 0001: 0.1mA ... <b>1010 1111: 17.5mA</b> ... 1111 1110: 25.4mA 1111 1111: 25.5mA

Table 33. LED2 CURRENT CONTROL Register

Register: 0x27		LED2 CURRENT CONTROL		
Bit	Bit Name	Default	Access	Bit Description
7:0	LED2_CURRENT	1010 1111	R/W	This register controls the output current of current source LED2 in 100 $\mu$ A steps from 0 $\mu$ A up to 25.5mA. 0000 0000: 0mA 0000 0001: 0.1mA ... <b>1010 1111: 17.5mA</b> ... 1111 1110: 25.4mA 1111 1111: 25.5mA

Table 34. LED3 CURRENT CONTROL Register

Register: 0x28		LED3 CURRENT CONTROL		
Bit	Bit Name	Default	Access	Bit Description
7:0	LED3_CURRENT	1010 1111	R/W	This register controls the output current of current source LED3 in 100 $\mu$ A steps from 0 $\mu$ A up to 25.5mA. 0000 0000: 0mA 0000 0001: 0.1mA ... <b>1010 1111: 17.5mA</b> ... 1111 1110: 25.4mA 1111 1111: 25.5mA



Table 35. LED4 CURRENT CONTROL Register

Register: 0x29		LED4 CURRENT CONTROL		
Bit	Bit Name	Default	Access	Bit Description
7:0	LED4_CURRENT	1010 1111	R/W	This register controls the output current of current source LED4 in 100µA steps from 0µA up to 25.5mA. 0000 0000: 0mA 0000 0001: 0.1mA ... <b>1010 1111: 17.5mA</b> ... 1111 1110: 25.4mA 1111 1111: 25.5mA

Table 36. LED5 CURRENT CONTROL Register

Register: 0x2A		LED5 CURRENT CONTROL		
Bit	Bit Name	Default	Access	Bit Description
7:0	LED5_CURRENT	1010 1111	R/W	This register controls the output current of current source LED5 in 100µA steps from 0µA up to 25.5mA. 0000 0000: 0mA 0000 0001: 0.1mA ... <b>1010 1111: 17.5mA</b> ... 1111 1110: 25.4mA 1111 1111: 25.5mA

Table 37. LED6 CURRENT CONTROL Register

Register: 0x2B		LED6 CURRENT CONTROL		
Bit	Bit Name	Default	Access	Bit Description
7:0	LED6_CURRENT	1010 1111	R/W	This register controls the output current of current source LED6 in 100µA steps from 0µA up to 25.5mA. 0000 0000: 0mA 0000 0001: 0.1mA ... <b>1010 1111: 17.5mA</b> ... 1111 1110: 25.4mA 1111 1111: 25.5mA

Table 38. LED7 CURRENT CONTROL Register

Register: 0x2C		LED7 CURRENT CONTROL		
Bit	Bit Name	Default	Access	Bit Description
7:0	LED7_CURRENT	1010 1111	R/W	This register controls the output current of current source LED7 in 100µA steps from 0µA up to 25.5mA. 0000 0000: 0mA 0000 0001: 0.1mA ... <b>1010 1111: 17.5mA</b> ... 1111 1110: 25.4mA 1111 1111: 25.5mA

Table 39. LED8 CURRENT CONTROL Register

Register: 0x2D		LED8 CURRENT CONTROL		
Bit	Bit Name	Default	Access	Bit Description
7:0	LED8_CURRENT	1010 1111	R/W	This register controls the output current of current source LED8 in 100µA steps from 0µA up to 25.5mA. 0000 0000: 0mA 0000 0001: 0.1mA ... <b>1010 1111: 17.5mA</b> ... 1111 1110: 25.4mA 1111 1111: 25.5mA

Table 40. LED9 CURRENT CONTROL Register

Register: 0x2E		LED9 CURRENT CONTROL		
Bit	Bit Name	Default	Access	Bit Description
7:0	LED9_CURRENT	1010 1111	R/W	This register controls the output current of current source LED9 in 100µA steps from 0µA up to 25.5mA. 0000 0000: 0mA 0000 0001: 0.1mA ... <b>1010 1111: 17.5mA</b> ... 1111 1110: 25.4mA 1111 1111: 25.5mA

### 8.10.8 MISC

This register contains miscellaneous control bits like the clock detection. Program execution is clocked with internal 32.7 kHz clock or with external clock. External clock can be used if a clock signal is present on CLK-pin. The external clock frequency must be 32.7 kHz in order to meet the timing specifications of the datasheet and for correct operation. If a higher or a lower frequency is used, it will affect on the program execution engine operation speed. The detector block does not limit the maximum frequency. External clock status can be checked with read only bit EXT\_CLK\_USED in register address 3A, when the external clock detection is enabled (Bit [1] CLK\_DET\_EN = high).

If external clock is not used in the application, CLK pin should be connected to GND to avoid oscillation on this pin and extra current consumption.

Table 41. OUTPUT ON/OFF CONTROL LSB Register

Register: 0x05		OUTPUT ON/OFF CONTROL LSB		
Bit	Bit Name	Default	Access	Bit Description
7	VARIABLE_D_SEL	0	R/W	The variable D can be linked to two different sources. The default source for variable D is register 0x3C but it can be assigned to the LED test ADC output. This allows, for example, program execution control with an analog signal. <b>0: variable D source is register 0x3C</b> 1: variable D source is LED test ADC.
6	EN_AUTO_INCR	1	R/W	The automatic increment feature of the serial bus address enables a quick memory write of successive registers within one transmission. 0: serial bus address automatic increment is disabled. <b>1: serial bus address automatic increment is enabled.</b>
5	POWERSAVE_EN	0	R/W	Please refer to section 8.14.9 for a detailed description of the powersave mode of AS3661. <b>0: power save mode is disabled.</b> 1: power save mode is enabled.
4:3	CP_MODE	00	R/W	This register bits control the operation mode of the integrated charge pump. The charge pump can be switched off, forced to bypass mode, forced to 1.5x mode and automatic operation. <b>00: CP is switched off.</b> 01: CP is forced to bypass mode (1x). 10: CP is forced to 1.5x mode (output voltage is 4.5V) 11: CP is in automatic mode depending on load conditions
2	PWM_PS_EN	0	R/W	For a detailed description of this power save mode please refer to section 8.14.10. This mode can only be used if the CP is in off mode or 1x mode. <b>0: PWM power save mode disabled.</b> 1: PWM power save mode enabled.
1	CLK_DET_EN	00	R/W	The following bits define the clock selection of AS3661. <b>00: forced external clock (CLK pin).</b> 01: forced internal clock. 10: automatic clock selection. 11: internal clock.
0	INT_CLK_EN			

### 8.10.9 ENGINEx PC

The program counter defines the starting value for each program execution engine. It can be any value between 000 0000 to 101 1111. The maximum value depends on program memory allocation between the three program execution engines.

Table 42. ENGINE1 PC Register

Register: 0x37		ENGINE1 PC		
Bit	Bit Name	Default	Access	Bit Description
6:0	ENGINE1_PC	000 0000	R/W	Program counter value for execution engine1 from 000 0000 to 101 1111 depending on the memory allocation of the application.

Table 43. ENGINE2 PC Register

Register: 0x38		ENGINE2 PC		
Bit	Bit Name	Default	Access	Bit Description
6:0	ENGINE2_PC	000 0000	R/W	Program counter value for execution engine2 from 000 0000 to 101 1111 depending on the memory allocation of the application.

Table 44. ENGINE3 PC Register

Register: 0x39		ENGINE3 PC		
Bit	Bit Name	Default	Access	Bit Description
6:0	ENGINE3_PC	000 0000	R/W	Program counter value for execution engine 3 from 000 0000 to 101 1111 depending on the memory allocation of the application.

### 8.10.10 STATUS/INTERRUPT

This register contains several status and interrupt registers.

Table 45. STATUS / INTERRUPT Register

Register: 0x3A		STATUS / INTERRUPT		
Bit	Bit Name	Default	Access	Bit Description
7	LEDTEST_MEAS_DONE	0	R/W	This bit indicates when the LED test is done, and the result is written to the LED_TEST_ADC register (0x42). Typically the conversion takes 2.7 milliseconds to complete. The bit will not be cleared after conversion. Each write command to this register starts another conversion. <b>0: LED test not done.</b> 1: LED test done.
6	MASK_BUSY	1	R/W	Mask bit for interrupts generated by STARTUP_BUSY or ENGINE_BUSY. 0: External interrupt will be generated when STARTUP_BUSY or ENGINE_BUSY condition is no longer true. Reading the register 3A clears the status bits [5:4] and releases INT pin to high state. <b>1: Interrupt events will be masked i.e. no external interrupt will be generated from STARTUP_BUSY or ENGINE_BUSY event (default).</b>

Table 45. STATUS / INTERRUPT Register

Register: 0x3A		STATUS / INTERRUPT			
Bit	Bit Name	Default	Access	Bit Description	
5	STARTUP_BUSY	0	R	<p>A status bit which indicates that the device is running the internal start-up sequence. Please note that STARTUP_BUSY bit is always "1" when CHIP_EN bit is "0". Please refer to section 8.5 for detailed startup mode description.</p> <p><b>0: internal start-up sequence completed.</b> 1: internal start-up sequence running.</p>	
4	ENGINE_BUSY	0	R	<p>A status bit which indicates that a program execution engine is clearing internal registers. Serial bus master should not write or read program memory, or registers 0x00, 0x37 to 0x39 or 0x4C to 0x4E, when this bit is set to "1".</p> <p><b>0: engine ready.</b> 1: at least one of the engines is clearing internal registers.</p>	
3	EXT_CLK_USED	0	R	<p>This bit is high when external clock signal on CLK pin is detected. CLK_DET_EN bit high in address 36 enables the clock detection.</p> <p><b>0: external clock not detected.</b> 1: external clock detected.</p>	
2	ENG1_INT	0	R	<p>This is the interrupt status bit for program execution engine 1. The bit is set by END or INT instruction. Reading the interrupt bit clears the interrupt.</p> <p><b>0: interrupt unset/cleared.</b> 1: interrupt set.</p>	
1	ENG2_INT	0	R	<p>This is the interrupt status bit for program execution engine 2. The bit is set by END or INT instruction. Reading the interrupt bit clears the interrupt.</p> <p><b>0: interrupt unset/cleared.</b> 1: interrupt set.</p>	
0	ENG3_INT	0	R	<p>This is the interrupt status bit for program execution engine 3. The bit is set by END or INT instruction. Reading the interrupt bit clears the interrupt.</p> <p><b>0: interrupt unset/cleared.</b> 1: interrupt set.</p>	

### 8.10.11 GPO

AS3661 has one General Purpose Output pin (GPO). Status of the pin can be controlled with this register. Also, INT pin can be configured to function as a GPO by setting the bit EN\_GPO\_INT. When INT is configured to function as a GPO, output level is defined by the VBAT voltage.

When INT pin's GPO function is disabled, it operates as an open drain pin. INT signal is active low, i.e. when interrupt signal is send, the pin is pulled to GND. External pull-up resistor is needed for proper functionality.

Table 46. GPO Register

Register: 0x3B		GPO		
Bit	Bit Name	Default	Access	Bit Description
2	INT_CONF	0	R/W	This bit defines the function of GPO pin. It can either be configured as interrupt pin or as general purpose output pin. <b>0: INT pin is set to function as an interrupt pin.</b> 1: INT pin is configured to function as a GPO.
1	GPO	0	R/W	This register controls the state of pin GPO. <b>0: GPO pin state is low.</b> 1: GPO pin state is high. GPO pin is a digital CMOS output, and no pulldown resistor is needed.
0	INT_GPO	0	R/W	If INT pin is defined as general purpose output (INT_CONF bit must be set to "1"), it is possible to control the INT pin with this bit. <b>0: INT pin state is low (if INT_CONF = 1).</b> 1: INT pin state is high (if INT_CONF = 1).

### 8.10.12 VARIABLE

The variable can be used to store data in order to control for example the data flow.

Table 47. GPO Register

Register: 0x3C		GPO		
Bit	Bit Name	Default	Access	Bit Description
7:0	VARIABLE_D	0000 0000	R/W	These bits are used for storing a global 8-bit variable. Variable can be used to control program flow.

### 8.10.13 RESET

Table 48. RESET Register

Register: 0x3D		RESET		
Bit	Bit Name	Default	Access	Bit Description
7:0	RESET	0000 0011	R/W	Writing 11111111 into this register resets the AS3661. Internal registers are reset to the default values. Reading RESET register returns 00000011.

### 8.10.14 TEMP ADC CONTROL

Table 49. TEMP ADC CONTROL Register

Register: 0x3E		TEMP ADC CONTROL		
Bit	Bit Name	Default	Access	Bit Description
7	TEMP_MEAS_BUSY	0	R	Indicates the status of the temperature measurement ADC of AS3661. <b>0: temperature measurements done or not activated.</b> 1: temperature measurement active.
2	EN_TEMP_SENSOR	0	R/W	Every time when EN_TEMP_SENSOR is written high a new measurement period is started. The length of the measurement period depends on temperature. At 25°C a measurement takes 20 milliseconds. Temperature can be read from register 0x3F. <b>0: temperature sensor disabled.</b> 1: enable internal temperature sensor and start measurement.
1	CONTINUOUS_CONV	0	R/W	When EN_TEMP_SENSOR bit is set to "1" it is possible to enable a continuous temperature conversation setting the CONTINUOUS_CONV bit in this register. <b>0: new temperature measurement period initiated during start-up or after exit from power save mode.</b> 1: continuous temperature measurement. Not active when the device is in powersave.
0	SEL_EXT_TEMP	0	R/W	It is possible to link the temperature compensation register either to the internal temperature measurement result register 0x3F or to the TEMPERATURE WRITE register 0x40. This register can be used to store the temperature of an external temperature measurement device to AS3661 in order to use it for LED temperature compensation. <b>0: temperature compensation source register addr 3FH.</b> 1: temperature compensation source register addr 40H.

### 8.10.15 TEMPERATURE READ

Table 50. TEMPERATURE READ Register

Register: 0x3F		TEMPERATURE READ		
Bit	Bit Name	Default	Access	Bit Description
7:0	TEMPERATURE_READ	0001 1001	R	These bits are used for storing an 8-bit temperature reading acquired from the internal temperature sensor. This register is a read-only register. Temperature reading is stored in 8-bit two's complement format, see the table below. 1101 1010: -38°C ... <b>0001 1001: 25°C</b> ... 0101 1000: 88°C 0101 1001: 89°C

**Note:** When writing temperature data outside the range of the temperature compensation: Values greater than 89°C will be set to 89°C; values less than -38°C will be set to -38°C.

### 8.10.16 TEMPERATURE WRITE

Table 51. TEMPERATURE WRITE Register

Register: 0x40		TEMPERATURE WRITE		
Bit	Bit Name	Default	Access	Bit Description
7:0	TEMPERATURE_WRITE	0000 0000	R/W	<p>These bits are used for storing an 8-bit temperature reading acquired from an external temperature sensor, if such a sensor is used. Temperature reading is stored in 8-bit two's complement format, see the table below.</p> <p>1101 1010: -38°C ... <b>0001 1001: 25°C</b> ... 0101 1000: 88°C 0101 1001: 89°C</p>

**Note:** When writing temperature data outside the range of the temperature compensation: Values greater than 89°C will be set to 89°C; values less than -38°C will be set to -38°C.

### 8.10.17 LED TEST CONTROL

Table 52. LED TEST CONTROL Register

Register: 0x41		LED TEST CONTROL		
Bit	Bit Name	Default	Access	Bit Description
7	EN_LED_TEST_ADC	0	R/W	<p>Writing this bit high (1) fires single LED test conversation. Thus each time you want to start a conversion it is necessary to write a "1" to this register. The measurement cycle is 2.7 milliseconds per conversion.</p> <p><b>0: LED test measurement disabled.</b> 1: LED test measurement enabled</p>
6	EN_LED_TEST_INT	0	R/W	<p>This register enabled the interrupt for the LED test ADC. Interrupt can be cleared by reading STATUS/INTERRUPT register 0x3A.</p> <p><b>0: no interrupt signal will be send to the INT pin when the LED test is accomplished.</b> 1: interrupt signal will be send to the INT pin when the LED test is accomplished.</p>



Table 52. LED TEST CONTROL Register

Register: 0x41		LED TEST CONTROL		
Bit	Bit Name	Default	Access	Bit Description
5	CONTINUOUS_CONV	0	R/W	When EN_LED_TEST_ADC bit is set to "1", it is possible to enable a continuous conversion setting the CONTINUOUS_CONV bit to "1" in this register. <b>0: continuous conversion is disabled.</b> 1: continuous LED test measurement. Not active in powersave mode.
4:0	LED_TEST_CTRL	0 0000	R/W	These bits are used for choosing the LED driver output to be measured with the LED test ADC. In addition to the LED outputs it is possible to measure VDD , INT-pin and charge-pump output voltage as well. <b>0 0000: LED1</b> 0 0001: LED2 0 0010: LED3 0 0011: LED4 0 0100: LED5 0 0101: LED6 0 0110: LED7 0 0111: LED8 0 1000: LED9 0 1001 to 0 1110: reserved, do not use 0 1111: VCP 1 0000: VBAT 1 0001: INT-pin 10010 to 11111: reserved, do not use

### 8.10.18 LED TEST ADC

Table 53. LED TEST ADC Register

Register: 0x42		LED TEST ADC		
Bit	Bit Name	Default	Access	Bit Description
7:0	LED_TEST_ADC	N/A	R	This is used to store the LED test result. Read-only register. LED test ADC least significant bit corresponds to 30mV. The measured voltage V (typ.) is calculated as follows: $V = (\text{RESULT}(\text{DEC}) \times 0.03 - 1.478 \text{ V})$ . For example, if the result is 10100110 = 166(DEC), the measured voltage is 3.50V (typ.)(see Figure 28 on page 58).

Figure 28. LED Test Results vs. Measured Voltage

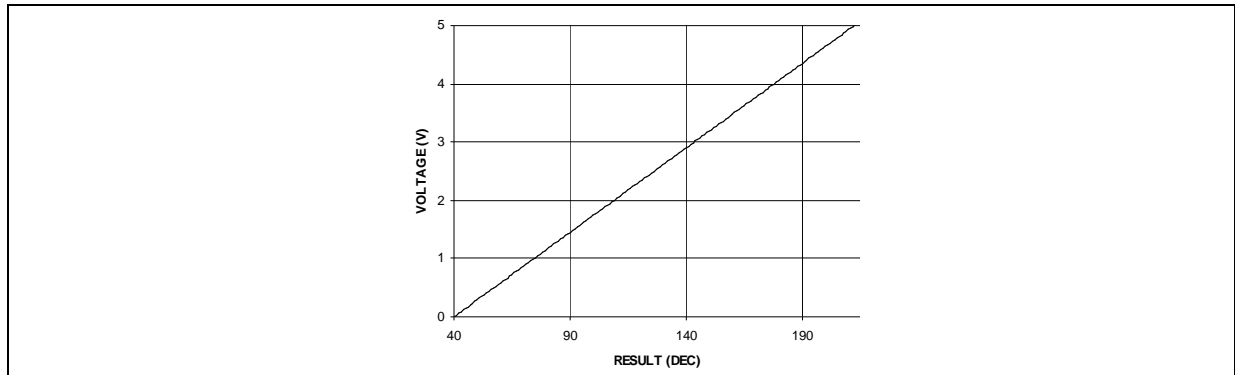

### 8.10.19 ENGINE1 VARIABLE A

Table 54. ENGINE1 VARIABLE A Register

Register: 0x45		ENGINE1 VARIABLE A		
Bit	Bit Name	Default	Access	Bit Description
7:0	ENGINE1_VARIABLE_A	0000 0000	R	These bits are used for engine 1 as a local variable. The register is a read only register and can be used for example for arithmetic operations with the program execution engine.

### 8.10.20 ENGINE2 VARIABLE A

Table 55. ENGINE2 VARIABLE A Register

Register: 0x46		ENGINE2 VARIABLE A		
Bit	Bit Name	Default	Access	Bit Description
7:0	ENGINE2_VARIABLE_A	0000 0000	R	These bits are used for engine 2 as a local variable. The register is a read only register and can be used for example for arithmetic operations with the program execution engine.

### 8.10.21 ENGINE3 VARIABLE A

Table 56. ENGINE3 VARIABLE A Register

Register: 0x47		ENGINE3 VARIABLE A		
Bit	Bit Name	Default	Access	Bit Description
7:0	ENGINE3_VARIABLE_A	0000 0000	R	These bits are used for engine 3 as a local variable. The register is a read only register and can be used for example for arithmetic operations with the program execution engine.

### 8.10.22 MASTER FADER1

Table 57. MASTER FADER1 Register

Register: 0x48		MASTER FADER1		
Bit	Bit Name	Default	Access	Bit Description
7:0	MASTER_FADER1	0000 0000	R/W	An 8-bit register to control all the LED-drivers mapped to MASTER FADER1. Master fader allows the user to control dimming of multiple LEDs with a single serial bus write. This is a faster method to control the dimming of multiple LEDs compared to the dimming done with the PWM registers (address 0x16 to 0x1E), which would need multiple writes.

### 8.10.23 49 MASTER FADER2

Table 58. MASTER FADER2 Register

Register: 0x49		MASTER FADER2		
Bit	Bit Name	Default	Access	Bit Description
7:0	MASTER_FADER2	0000 0000	R/W	An 8-bit register to control all the LED-drivers mapped to MASTER FADER2. Master fader allows the user to control dimming of multiple LEDs with a single serial bus write. This is a faster method to control the dimming of multiple LEDs compared to the dimming done with the PWM registers (address 0x16 to 0x1E), which would need multiple writes.

### 8.10.24 4A MASTER FADER3

Table 59. MASTER FADER3 Register

Register: 0x4A		MASTER FADER3		
Bit	Bit Name	Default	Access	Bit Description
7:0	MASTER_FADER3	0000 0000	R/W	An 8-bit register to control all the LED-drivers mapped to MASTER FADER3. Master fader allows the user to control dimming of multiple LEDs with a single serial bus write. This is a faster method to control the dimming of multiple LEDs compared to the dimming done with the PWM registers (address 0x16 to 0x1E), which would need multiple writes.

### 8.10.25 ENG1 PROG START ADDR

Table 60. ENG1 PROG START ADDR Register

Register: 0x4C		ENG1 PROG START ADDR		
Bit	Bit Name	Default	Access	Bit Description
6:0	ENG1_PROG_START_ADDR	000 0000	R/W	The program memory start address for program execution engine 1 is defined in this register.

### 8.10.26 ENG2 PROG START ADDR

Table 61. ENG2 PROG START ADDR Register

Register: 0x4D		ENG2 PROG START ADDR		
Bit	Bit Name	Default	Access	Bit Description
6:0	ENG2_PROG_START_ADDR	000 0000	R/W	The program memory start address for program execution engine 2 is defined in this register.

### 8.10.27 ENG3 PROG START ADDR

Table 62. ENG2 PROG START ADDR Register

Register: 0x4E		ENG3 PROG START ADDR		
Bit	Bit Name	Default	Access	Bit Description
6:0	ENG3_PROG_START_ADDR	000 0000	R/W	The program memory start address for program execution engine 3 is defined in this register.

### 8.10.28 PROG MEM PAGE SELECT

Table 63. PROG MEM PAGE SEL Register

Register: 0x4F		PROG MEM PAGE SEL		
Bit	Bit Name	Default	Access	Bit Description
2:0	PAGE_SEL	000	R/W	<p>These bits select the program memory page. The program memory is divided into six pages of 16 instructions; thus the total amount of the program memory is 96 instructions.</p> <p><b>000: Program Memory 0x00 - 0x0F selected.</b>            001: Program Memory 0x10 - 0x1F selected.            010: Program Memory 0x20 - 0x2F selected.            011: Program Memory 0x30 - 0x3F selected.            100: Program Memory 0x40 - 0x4F selected.            101: Program Memory 0x50 - 0x5F selected.</p>

### 8.10.29 ENG1 MAPPING MSB

Table 64. ENG1 MAPPING MSB Register

Register: 0x70		ENG1 MAPPING MSB		
Bit	Bit Name	Default	Access	Bit Description
7	ENG1_GPO	0	R	<p><b>0: GPO pin non-mapped to the program exec. engine 1.</b>            1: GPO pin is mapped to the program execution engine 1.</p>
0	ENG1_LED9	0	R	<p><b>0: LED9 pin non-mapped to the program exec. engine1.</b>            1: LED9 pin is mapped to the program execution engine 1.</p>

### 8.10.30 71H ENG1 MAPPING LSB

Table 65. ENG1 MAPPING LSB Register

Register: 0x71		ENG1 MAPPING LSB		
Bit	Bit Name	Default	Access	Bit Description
7	ENG1_LED8	0	R	<p><b>0: LED8 pin non-mapped to the program exec. engine 1.</b>            1: LED8 pin is mapped to the program execution engine 1.</p>
6	ENG1_LED7	0	R	<p><b>0: LED7 pin non-mapped to the program exec. engine 1.</b>            1: LED7 pin is mapped to the program execution engine 1.</p>
5	ENG1_LED6	0	R	<p><b>0: LED6 pin non-mapped to the program exec. engine 1.</b>            1: LED6 pin is mapped to the program execution engine1.</p>
4	ENG1_LED5	0	R	<p><b>0: LED5 pin non-mapped to the program exec. engine 1.</b>            1: LED5 pin is mapped to the program execution engine 1.</p>
3	ENG1_LED4	0	R	<p><b>0: LED4 pin non-mapped to the program exec. engine 1.</b>            1: LED4 pin is mapped to the program execution engine 1.</p>
2	ENG1_LED3	0	R	<p><b>0: LED3 pin non-mapped to the program exec. engine 1.</b>            1: LED3 pin is mapped to the program execution engine 1.</p>
1	ENG1_LED2	0	R	<p><b>0: LED2 pin non-mapped to the program exec. engine 1.</b>            1: LED2 pin is mapped to the program execution engine 1.</p>
0	ENG1_LED1	0	R	<p><b>0: LED1 pin non-mapped to the program exec. engine 1.</b>            1: LED1 pin is mapped to the program execution engine 1.</p>

### 8.10.31 ENG2 MAPPING MSB

Table 66. ENG2 MAPPING MSB Register

Register: 0x72		ENG2 MAPPING MSB		
Bit	Bit Name	Default	Access	Bit Description
7	ENG2_GPO	0	R	<b>0: GPO pin non-mapped to the program exec. engine 2.</b> 1: GPO pin is mapped to the program execution engine 2.
0	ENG2_LED9	0	R	<b>0: LED9 pin non-mapped to the program exec. engine2.</b> 1: LED9 pin is mapped to the program execution engine 2.

### 8.10.32 ENG2 MAPPING LSB

Table 67. ENG2 MAPPING LSB Register

Register: 0x73		ENG2 MAPPING LSB		
Bit	Bit Name	Default	Access	Bit Description
7	ENG2_LED8	0	R	<b>0: LED8 pin non-mapped to the program exec. engine 2.</b> 1: LED8 pin is mapped to the program execution engine 2.
6	ENG2_LED7	0	R	<b>0: LED7 pin non-mapped to the program exec. engine 2.</b> 1: LED7 pin is mapped to the program execution engine 2.
5	ENG2_LED6	0	R	<b>0: LED6 pin non-mapped to the program exec. engine 2.</b> 1: LED6 pin is mapped to the program execution engine 2.
4	ENG2_LED5	0	R	<b>0: LED5 pin non-mapped to the program exec. engine 2.</b> 1: LED5 pin is mapped to the program execution engine 2.
3	ENG2_LED4	0	R	<b>0: LED4 pin non-mapped to the program exec. engine 2.</b> 1: LED4 pin is mapped to the program execution engine 2.
2	ENG2_LED3	0	R	<b>0: LED3 pin non-mapped to the program exec. engine 2.</b> 1: LED3 pin is mapped to the program execution engine 2.
1	ENG2_LED2	0	R	<b>0: LED2 pin non-mapped to the program exec. engine 2.</b> 1: LED2 pin is mapped to the program execution engine 2.
0	ENG2_LED1	0	R	<b>0: LED1 pin non-mapped to the program exec. engine 2.</b> 1: LED1 pin is mapped to the program execution engine 2.

### 8.10.33 ENG3 MAPPING MSB

Table 68. ENG3 MAPPING MSB Register

Register: 0x74		ENG3 MAPPING MSB		
Bit	Bit Name	Default	Access	Bit Description
7	ENG3_GPO	0	R	<b>0: GPO pin non-mapped to the program exec. engine 3.</b> 1: GPO pin is mapped to the program execution engine 3.
0	ENG3_LED9	0	R	<b>0: LED9 pin non-mapped to the program exec. engine 3.</b> 1: LED9 pin is mapped to the program execution engine 3.

### 8.10.34 ENG3 MAPPING LSB

Table 69. ENG3 MAPPING LSB Register

Register: 0x75		ENG3 MAPPING LSB		
Bit	Bit Name	Default	Access	Bit Description
7	ENG3_LED8	0	R	<b>0: LED8 pin non-mapped to the program exec. engine 3.</b> 1: LED8 pin is mapped to the program execution engine 3.
6	ENG3_LED7	0	R	<b>0: LED7 pin non-mapped to the program exec. engine 3.</b> 1: LED7 pin is mapped to the program execution engine 3.
5	ENG3_LED6	0	R	<b>0: LED6 pin non-mapped to the program exec. engine 3.</b> 1: LED6 pin is mapped to the program execution engine 3.
4	ENG3_LED5	0	R	<b>0: LED5 pin non-mapped to the program exec. engine 3.</b> 1: LED5 pin is mapped to the program execution engine 3.
3	ENG3_LED4	0	R	<b>0: LED4 pin non-mapped to the program exec. engine 3.</b> 1: LED4 pin is mapped to the program execution engine 3.
2	ENG3_LED3	0	R	<b>0: LED3 pin non-mapped to the program exec. engine 3.</b> 1: LED3 pin is mapped to the program execution engine 3.
1	ENG3_LED2	0	R	<b>0: LED2 pin non-mapped to the program exec. engine 3.</b> 1: LED2 pin is mapped to the program execution engine 3.
0	ENG3_LED1	0	R	<b>0: LED1 pin non-mapped to the program exec. engine 3.</b> 1: LED1 pin is mapped to the program execution engine 3.

### 8.10.35 GAIN CHANGE CTRL

With hysteresis and timer bits the user can optimize the charge pump performance to better meet the requirements of the application at hand. Some applications need to be optimized for efficiency and others need to be optimized for minimum EMI, for example.

Table 70. GAIN CHANGE CTRL Register

Register: 0x76		GAIN CHANGE CTRL		
Bit	Bit Name	Default	Access	Bit Description
7:6	TRESHOLD	00	R/W	<p>Bits set the threshold voltage at which the charge pump gain changes from 1.5x to 1x. The threshold voltage is defined as the voltage difference between highest voltage output (LED1 to LED6) and input voltage <math>V_{BAT}</math>: <math>V_{TRESHOLD} = V_{BAT} - MAX</math> (voltage on LED1 to LED6). If <math>V_{TRESHOLD}</math> is larger than the set value (100mV to 400mV), the charge pump is in 1x mode.</p> <p><b>00: 400mV</b>            01: 300mV            10: 200mV            11: 100mV</p>
5	ADAPTIVE_TRESH_EN	0	R/W	<p>Gain change hysteresis prevents the mode from toggling back and forth (1x -&gt; 1.5x -&gt; 1x...), which would cause ripple on <math>V_{IN}</math> and LED flicker. When the adaptive threshold is enabled, the width of the hysteresis region depends on the choice of TRESHOLD bits (see above), saturation of the current sources, charge pump load current, PWM overlap and temperature.</p> <p><b>0: Adaptive threshold disabled.</b>            1: Adaptive threshold enabled.</p>
4:3	TIMER	00	R/W	<p>A forced mode change from 1.5x to 1.0x is attempted at the interval specified with these bits. Mode change is allowed if there is enough voltage over the LED drivers to ensure proper operation. Set FORCE_1x to "1" (see below) to activate this feature.</p> <p><b>00: 5ms</b>            01: 10ms            10: 50ms            11: infinite</p>
2	FORCE_1x	0	R	<p>Activates forced mode change. In forced mode charge pump mode change from 1.5x to 1x is attempted at the interval specified with the TIMER bits.</p> <p><b>0: forced mode changes disabled.</b>            1: forced mode changes disabled.</p>

**Note:** Values above are typical and should not be used as product specification. Writing to TRESHOLD [7:6] bits by the user overrides factory settings. Factory settings aren't user accessible.

## 8.11 Instruction Set

AS3661 has three independent programmable execution engines. All the program execution engines have their own program memory block allocated by the user. Note that in order to access program memory the operation mode needs to be load program, at least for one of the three program execution engines. Program execution is clocked with 32 768Hz clock. This clock can be generated internally or external 32 kHz clock can be connected to CLK32K pin. Using external clock enables synchronization of LED timing to the external clock signal.

Supported instruction set is listed in the tables below:

Table 71. LED Driver Instructions

LED Driver Instructions	Compiler Command	Bit [15]	Bit [14]	Bit [13]	Bit [12]	Bit [11]	Bit [10]	Bit [9]	Bit [8]	Bit [7]	Bit [6]	Bit [5]	Bit [4]	Bit [3]	Bit [2]	Bit [1]	Bit [0]	
ramp <sup>1</sup>	RMP	0	pre-scale	step time						sign	# of increments							
ramp <sup>2</sup>	RWV	1	0	0	0	0	1	0	0	0	0	pre-scale	sign	step time	# of increments			
set_pwm <sup>1</sup>	SPW	0	1	0	0	0	0	0	0	PWM value								
set_pwm <sup>2</sup>	SPV	1	0	0	0	0	1	0	0	0	1	1	0	0	0	PWM value		
wait	WAIT	0	pre-scale	time						0	0	0	0	0	0	0	0	0

1. This opcode is used with numerical operands.
2. This opcode is used with variables.

Table 72. LED Mapping Instructions

LED Mapping Instructions	Compiler Command	Bit [15]	Bit [14]	Bit [13]	Bit [12]	Bit [11]	Bit [10]	Bit [9]	Bit [8]	Bit [7]	Bit [6]	Bit [5]	Bit [4]	Bit [3]	Bit [2]	Bit [1]	Bit [0]	
mux_ld_start	MLS	1	0	0	1	1	1	1	0	0	SRAM address 0-95							
mux_map_start	MMS	1	0	0	1	1	1	0	0	0								
mux_ld_end	MLE	1	0	0	1	1	1	0	0	1								
mux_sel	MSL	1	0	0	1	1	1	0	1	0	LED select							
mux_clr	MCL	1	0	0	1	1	1	0	1	0	0	0	0	0	0	0	0	0
mux_map_next	MMN	1	0	0	1	1	1	0	1	1	0	0	0	0	0	0	0	0
mux_map_prev	MMP	1	0	0	1	1	1	0	1	1	1	0	0	0	0	0	0	0
mux_ld_next	MLN	1	0	0	1	1	1	0	1	1	0	0	0	0	0	0	0	1



Table 72. LED Mapping Instructions

LED Mapping Instructions	Compiler Command	Bit [15]	Bit [14]	Bit [13]	Bit [12]	Bit [11]	Bit [10]	Bit [9]	Bit [8]	Bit [7]	Bit [6]	Bit [5]	Bit [4]	Bit [3]	Bit [2]	Bit [1]	Bit [0]
mux_ld_prev	MLP	1	0	0	1	1	1	0	1	1	1	0	0	0	0	0	1
mux_ld_addr	MLA	1	0	0	1	1	1	1	1	0	SRAM address 0-95						
mux_map_addr	MMA	1	0	0	1	1	1	1	1	1							

Table 73. Branch Instructions

Branch Instructions	Compiler Command	Bit [15]	Bit [14]	Bit [13]	Bit [12]	Bit [11]	Bit [10]	Bit [9]	Bit [8]	Bit [7]	Bit [6]	Bit [5]	Bit [4]	Bit [3]	Bit [2]	Bit [1]	Bit [0]
rst	RST	0	0	0	0	0	0	0	0	0	0	0	0	0	0	0	0
branch <sup>1</sup>	BRN	1	0	1	loop count						step number						
branch <sup>2</sup>	BRV	1	0	0	0	0	1	1	step number						loop count		
Int	INT	1	1	0	0	0	1	0	0	0	0	0	0	0	0	0	0
end	END	1	1	0	int	reset	0	0	0	0	0	0	0	0	0	0	0
trigger	TRG	1	1	1	wait for trigger					send a trigger					0		
					ext.trig	x	x	E3	E2	E1	ext.trig	X	X	E3		E2	E1
jne	JNE	1	0	0	0	1	0	0	Number of instructions to be skipped if the operation returns true				variable1		variable2		
jl	JL	1	0	0	0	1	0	1									
jge	JGE	1	0	0	0	1	1	0									
je	JE	1	0	0	0	1	1	1									

1. This opcode is used with numerical operands.
2. This opcode is used with variables.

**Note:** x stands for 'don't care'

Table 74. Data Transfer and Arithmetic Instructions

Arithmetic Instructions	Compiler Command	Bit [15]	Bit [14]	Bit [13]	Bit [12]	Bit [11]	Bit [10]	Bit [9]	Bit [8]	Bit [7]	Bit [6]	Bit [5]	Bit [4]	Bit [3]	Bit [2]	Bit [1]	Bit [0]	
ld	LD	1	0	0	1	target variable		0	0	8-bit value								
add <sup>1</sup>	ADN	1	0	0	1			0	1	8-bit value								
add <sup>2</sup>	ADV	1	0	0	1			1	1	0	0	0	0	variable1	variable2			
sub <sup>1</sup>	SBN	1	0	0	1			1	0	8-bit value								
sub <sup>2</sup>	SBV	1	0	0	1			1	1	0	0	0	1	variable1	variable2			

1. This opcode is used with numerical operands.
2. This opcode is used with variables.

## 8.12 LED Driver Instructions

### 8.12.1 RAMP (Numerical Operands)

This is the instruction useful for smoothly changing from one PWM value into another PWM value on the LED1 to LED9 outputs, in other words generating ramps (with a negative or positive slope). AS3661 allows programming very fast and very slow ramps. Ramp instruction generates a PWM ramp, using the effective PWM value as a starting value. At each ramp step the output is incremented /decremented by one unit, unless the step time span is 0 or # of increments is 0. Time span for one ramp step is defined with prescale -bit [14] and step time -bits [13:9]. Prescale = 0 sets 0.49 ms cycle time and prescale = 1 sets 15.6 ms cycle time; so the minimum time span for one step is 0.49 ms (prescale \* step time span = 0.49ms x 1) and the maximum time span is 15.6 ms x 31 = 484ms/step. If all the step time bits [13:9] are set to zero, output value is incremented / decremented during one prescale on the whole. Number of increment's value defines how many steps will be taken during one ramp instruction: Increment maximum value is 255d, which corresponds increment from zero value to the maximum value. If PWM reaches minimum/maximum value (0/255) during the ramp instruction, ramp instruction will be executed to the end regardless of saturation. This enables ramp instruction to be used as a combined ramp & wait instruction. Ramp instruction is the wait instruction when the increment bits [7:0] are set to zero.

**COMPILER COMMAND SYNTAX:** *RMP, prescale[1], step time[4], sign[1], number of increments[8];*

Table 75. RMP Parameter Description

Name	Value	Description
prescale	0	Divides master clock (32 768 Hz) by 16 = 2048 Hz -> 0.488 ms cycle time
	1	Divides master clock (32 768 Hz) by 512 = 64 Hz -> 15.625 ms cycle time
step time	0-31	One ramp increment done in (step time) x (prescale).
sign	0	Increase PWM output
	1	Decrease PWM output
# of increments	0-255	The number of increment/decrement cycles. Note: Value 0 takes the same time as increment by 1, but it is the wait instruction.

#### 8.12.1.1 RMP Application Example

Let's say that the LED dimming is controlled according to the linear scale and effective PWM value at the moment t=0 is 140d (~55%), as shown in the figure below, and we want to reach a PWM value of 148d (~58%) at the moment t = 1.5s. The parameters for the RAMP instruction will be:

- Prescale = 1 (15.625 ms cycle time)
- Step time = 12 (step time span will be 12\*15.625 ms = 187.5 ms)
- Sign = 0 (increase PWM output)
- Number of increments = 8 (take 8 steps)

**COMPILER COMMAND SYNTAX EXAMPLE:** *RMP, 1, 12, 0, 8;*

Figure 29. RAMP Instruction Example

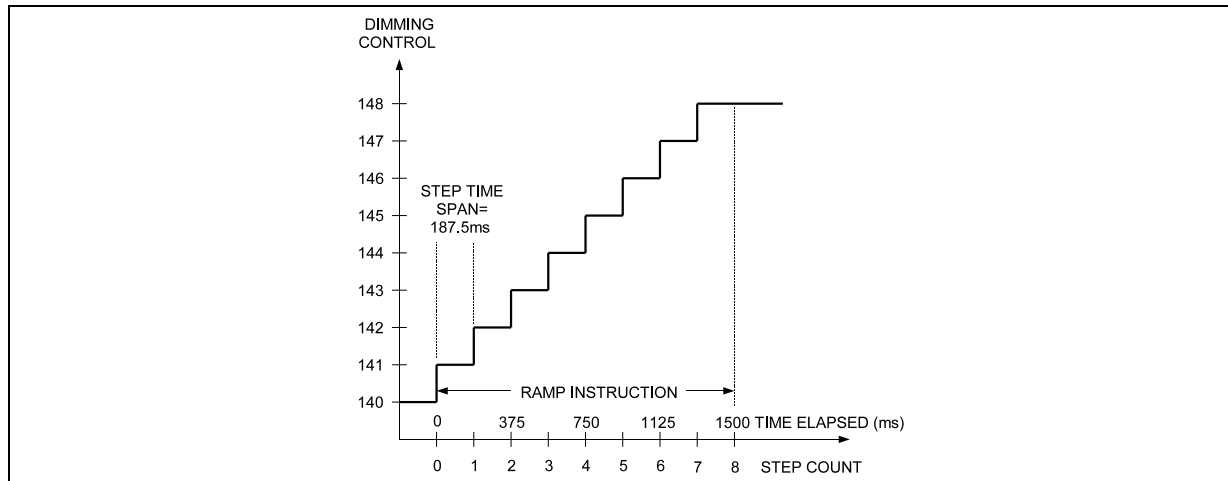

### 8.12.2 RAMP (Variables)

Programming ramps with variables is very similar to programming ramps with numerical operands. The only difference is that step time and number of increments are captured from variable registers, when the instruction execution is started. If the variables are updated after starting the instruction execution, it will have no effect on instruction execution. Again, at each ramp step the output is incremented/decremented by one unless step time is 0 or increment is 0. Time span for one step is defined with prescale and step time bits. Step time is defined with variable A, B, C or D. Variables A, B and C are set with Id-instruction. Variable D is a global variable and can be set by writing the VARIABLE register (address 0x3C). LED TEST ADC register (address 0x42) can be used as a source for the variable D, as well. Note: Variable A is the only local variable which can be read throughout the serial bus. Of course, the variable stored in 3CH can be read (and written), too. Setting register 0x06, 0x07, or 0x08 bit LOG\_EN high/low sets logarithmic (1) or linear ramp (0). By using the logarithmic ramp setting the visual effect appears like a linear ramp, because the human eye behaves in a logarithmic way.

**COMPILER COMMAND SYNTAX:** *RWV, prescale[1], sign[1], step time[2], number of increments[2];*

Table 76. RWV Parameter Description

Name	Value	Description	
prescale	0	Divides master clock (32 768 Hz) by 16 = 2048 Hz -> 0.488 ms cycle time	
	1	Divides master clock (32 768 Hz) by 512 = 64 Hz -> 15.625 ms cycle time	
sign	0	Increase PWM output	
	1	Decrease PWM output	
step time	0-3	One ramp increment done in (step time) x (prescale). Step time is loaded with the value (5 LSB bits) of the variable defined below.	
		1	local variable A
		2	local variable B
		3	local variable C
		4	register address 3CH variable D value, or register address 42H value.
		The value of the variable should be from 00001b to 11111b (1d to 31d) for correct operation.	

Table 76. RWV Parameter Description

Name	Value	Description	
# of increments	0-3	The number of increment/decrement cycles. Value is taken from variable defined below:	
		0	local variable A
		1	local variable B
		2	local variable C
		3	register address 0x3C variable D value, or register address 0x42 value.

### 8.12.2.1 RWV Application Example

Let's say that the LED dimming is controlled according to the linear scale and effective PWM value at the moment  $t=0$  is 0d (0%), and we want to reach a PWM value of 255d (100%) at the moment  $t = 3s$ . The parameters for the RAMP instruction will be:

- Prescale = 0 (0.488 ms cycle time)
- Step time = 4 (use variable D in register 0x3C with a value of 24d)
- Sign = 0 (increase PWM output)
- Number of increments = 0 (use local variable A which must be loaded with the value 255d)

**COMPILER COMMAND SYNTAX EXAMPLE:** `RMP, 0, 0, 4, 0;`

The example above gives us a ramp time of 2.987s ( $t_r = 0.488ms * 24 * 255$ ).

Figure 30. Ramp Instruction Example with Variables

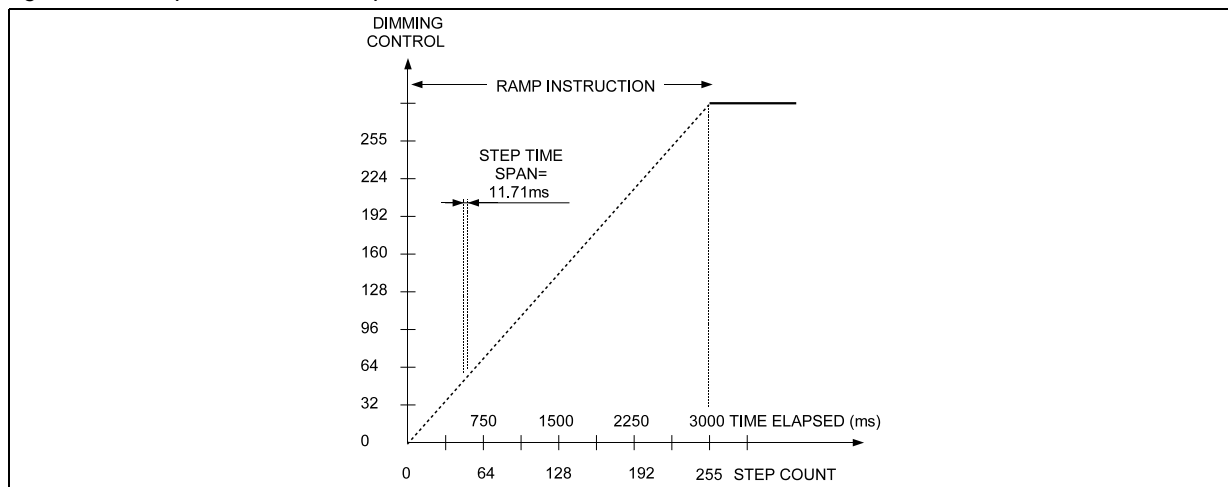

### 8.12.3 SET PWM (Numerical Operands)

This instruction is used for setting the PWM value on the outputs LED1 to LED9 without any ramps. Set PWM output value from 0 to 255 with PWM value bits [7:0]. Instruction execution takes sixteen 32 kHz clock cycles ( $=488\mu s$ ).

**COMPILER COMMAND SYNTAX:** `SPW, PWM Value[8];`

Table 77. SPW Parameter Description

Name	Value	Description
PWM Value	0-255	PWM output duty cycle 0 - 100%

### 8.12.3.1 SPW Application Example

The SPW command can be used to set the PWM duty cycle of the program execution engine. In the following example we want to set the duty cycle of the PWM output to 55% like in the ramp example in the previous section. The right PWM value can be calculated with the following formula:

$$\text{PWM value} = (\text{Duty Cycle} * 255 / 100) = 55\% * 255 / 100 = 140.$$

The predefined PWM value can be used as a starting point for dimming LEDs for example.

**COMPILER COMMAND SYNTAX:** *SPW, 140;*

### 8.12.4 SET PWM (Variables)

This instruction is used for setting the PWM value on the outputs LED1 to LED9 without any ramps. In comparison to the SPW command, this command is in combination with variables similar to the RWM example in one of the previous sections.

**COMPILER COMMAND SYNTAX:** *SPV, Variable[2];*

Table 78. SPW Parameter Description

Name	Value	Description	
Variable	0-3	0	local variable A
		1	local variable B
		2	global variable C
		3	register address 3CH variable D value, or register address 42H value.

#### 8.12.4.1 SPV Application Example

The purpose of the SPV command is basically the same one like with the SPW command in the previous section. The only difference is that this command allows the user to control the PWM duty cycle with the variables of the chip.

**COMPILER COMMAND SYNTAX EXAMPLE:** *SPV, 0;*

The example above shows the control of the duty cycle with the local variable A. If the local variable is for example loaded with a value of 100, the duty cycle of the PWM output is set to 39.2%.

### 8.12.5 WAIT

When a wait instruction is executed, the engine is set in a wait status and the PWM values on the outputs are frozen. This can be used for example to keep the LEDs enabled for a certain period of time before another up/down dimming process is being initiated.

**COMPILER COMMAND SYNTAX:** *WAIT, prescale[1], time[5];*

Table 79. WAIT Parameter Description

Name	Value	Description
Pre-scale	0	Divide master clock (32 768 Hz) by 16 which means 0.488 ms cycle time.
	1	Divide master clock (32 768 Hz) by 512 which means 15.625 ms cycle time.
time	1-31	Total wait time will be = (time) x (prescale). Maximum 484 ms, minimum 0.488 ms.

#### 8.12.5.1 WAIT Application Example

In the example shown below we want to have a target wait time of 125ms after dimming up the LEDs. In order to get the 100ms delay we select a prescaler value "1", which gives a cycle time of 15.625ms. If we divide the 100ms by the cycle time we get the right value for the time parameter which is 8.

**COMPILER COMMAND SYNTAX EXAMPLE:** *WAIT, 1, 8;*

## 8.13 LED Mapping Instructions

These instructions define the engine-to-LED mapping. The mapping information is stored in a table, which is stored in the SRAM (program memory of the AS3661). AS3661 has three program execution engines which can be mapped to 9 LED drivers or to one GPO pin. One engine can control one or multiple LED drivers. The first part of the program memory of AS3661 is usually used for LED driver programs of each sequencer. The LED mapping is usually put at the end of the program memory where the programmable multiplexer, shown in the block diagram below, gets the information which LED must be connected to what sequencer output.

Figure 31. LED Mapping Memory allocation

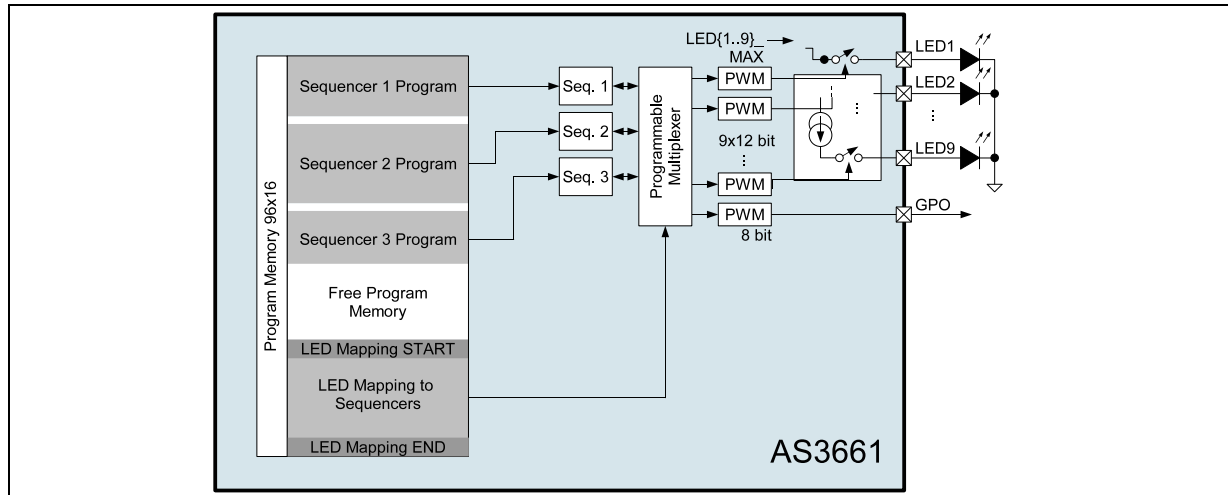

In order to control and define the mapping of the LEDs there are totally eleven instructions for the engine-to-LED-driver control: `mux_ld_start`, `mux_map_start`, `mux_ld_end`, `mux_sel`, `mux_clr`, `mux_map_next`, `mux_map_prev`, `mux_ld_next`, `mux_ld_prev`, `mux_ld_addr` and `mux_map_addr`. With these instructions it is also possible to change the LED mapping from one mapping to another mapping, which has been defined in the LED mapping table, forth and back to create again more complex light patterns.

### 8.13.1 MUX\_LD\_START

`Mux_ld_start` defines the start of the mapping table location in the memory.

**COMPILER COMMAND SYNTAX:** `MLS, SRAM address[7];`

Table 80. MLS Parameter Description

Name	Value	Description
SRAM address	0-95	Mapping table start address

#### 8.13.1.1 MLS Application Example

In this example we want to set the start address for the LED mapping table to 80d.

**COMPILER COMMAND SYNTAX EXAMPLE:** `MLS, 80;`

### 8.13.2 MUX\_LD\_END

`Mux_ld_end` defines the end of the mapping table location in the memory. It is very important to define the end address of the mapping table, otherwise it could happen if you use relative mapping commands, that the address pointer points to a position outside the mapping table due to the missing end address.

**COMPILER COMMAND SYNTAX:** `MLE, SRAM address[7];`

Table 81. MLE Parameter Description

Name	Value	Description
SRAM address	0-95	Mapping table end address

### 8.13.2.1 MLE Application Example

In this example we want to set the end address for the LED mapping table to 85d.

**COMPILER COMMAND SYNTAX EXAMPLE:** *MLE, 85;*

### 8.13.3 MUX\_MAP\_START

Mux\_map\_start defines the mapping table start address in the memory and the first row of the table will be activated (mapped) at the same time.

**COMPILER COMMAND SYNTAX:** *MMP, SRAM address[7];*

Table 82. MMP Parameter Description

Name	Value	Description
SRAM address	0-95	Mapping table start address

### 8.13.3.1 MMP Application Example

In the example we would like to set the start address to 80d. In addition to the definition of the start address of the mapping table the first LED mapping defined at address 80d gets activated. The difference to the MUSX\_LD\_START command, described in one of the previous sections, is that it only defines the start address without activating the LED mapping.

**COMPILER COMMAND SYNTAX EXAMPLE:** *MMP, 80;*

### 8.13.4 MUX\_SEL

With mux\_sel instruction one, and only one, LED driver (or the GPO-pin) can be connected to a program execution engine. Connecting multiple LEDs to one engine is done with the mapping table. After the mapping has been released from an LED, PWM register value will still control the LED brightness. If the mapping is released from the GPO pin, serial bus control takes over the GPO state.

**COMPILER COMMAND SYNTAX:** *MSL, LED Select[6]*

Table 83. MSL Parameter Description

Name	Value	Description	
LED Select	0-16	0	no drivers selected
		1	LED1 selected
		2	LED2 selected
		....	....
		16	GPO

### 8.13.4.1 MSL Application Example

In this example we would like to use the MSL command to map a single LED to a execution engine. Usually we do this with the mapping table but in case we want to use only a single LED on one sequencer it is possible to use the MSL command. The example command below shows the mapping of LED2 to the program execution engine.

**COMPILER COMMAND SYNTAX EXAMPLE:** *MSL, 2;*

### 8.13.5 MUX\_CLR

Mux\_clr clears engine-to-driver mapping. After the mapping has been released from an LED, PWM register value will still control the LED brightness. If the mapping is released from the GPO pin, serial bus control takes over the GPO state.

**COMPILER COMMAND SYNTAX:** *MCL;*

This command doesn't support any parameters.



### 8.13.6 MUX\_MAP\_NEXT

This instruction sets the next row active in the mapping table each time it is called. For example, if the 1st row is active at this moment, after mux\_map\_next instruction call the 2nd row will be active like in the block diagram shown in Figure 32 below.

Figure 32. MUX\_MAP\_NEXT Command

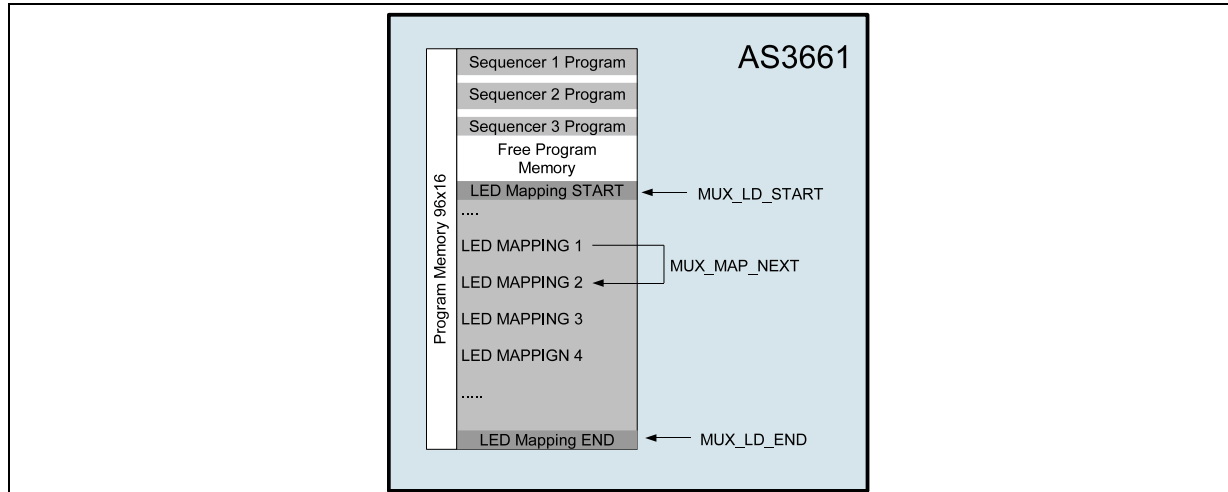

If the mapping table end address is reached, activation will roll to the mapping table start address next time when the mux\_map\_next instruction is called. Engine will not push a new PWM value to the LED driver output before set\_pwm or ramp instruction is executed. If the mapping has been released from an LED, the value in the PWM register will still control the LED brightness. If the mapping is released from the GPO pin, serial bus control takes over the GPO state.

**COMPILER COMMAND SYNTAX:** *MMN*;

This command doesn't support any parameters.

### 8.13.7 MUX\_MAP\_PREV

This instruction sets the previous row active in the mapping table each time it is called. For example, if the 3rd row is active at this moment, after mux\_map\_prev instruction call the 2nd row will be active like in block diagram shown in Figure 33 below.

Figure 33. MUX\_MAP\_PREV Command

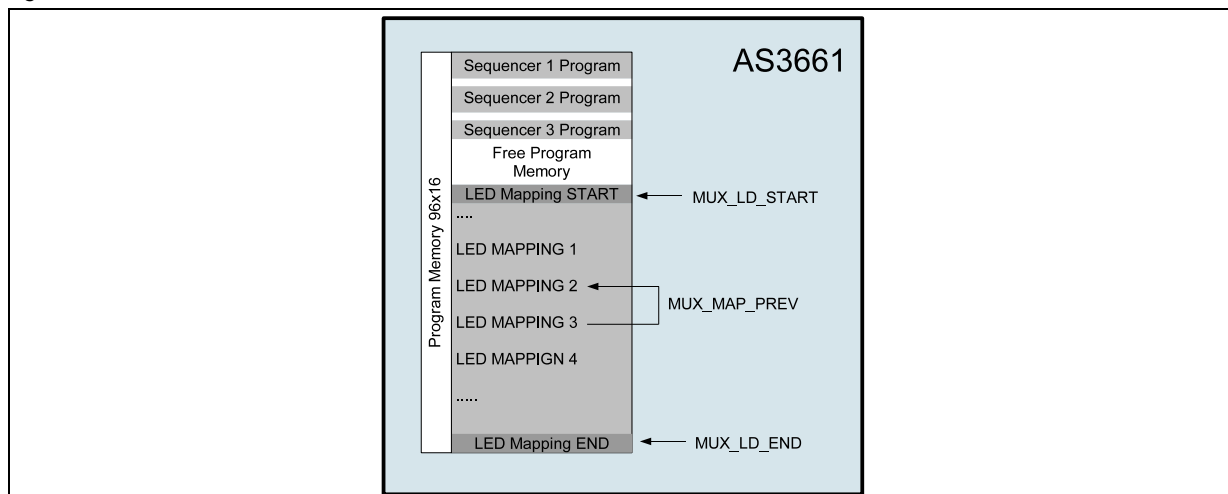

Figure 34.

If the mapping table start address is reached, activation will roll to the mapping table end address next time the `mux_map_prev` instruction is called. Engine will not push a new PWM value to the LED driver output before `set_pwm` or `ramp` instruction is executed. If the mapping has been released from an LED, the value in the PWM register will still control the LED brightness. If the mapping is released from the GPO pin, serial bus control takes over the GPO state.

**COMPILER COMMAND SYNTAX:** *MMP;*

This command doesn't support any parameters.

### 8.13.8 MUX\_LD\_NEXT

Similar than the `mux_map_next` instruction, but only the index pointer will be set to point to the next row i.e. no mapping will be set and the engine-to-LED-driver connection will not be updated.

**COMPILER COMMAND SYNTAX:** *MLN;*

This command doesn't support any parameters.

### 8.13.9 MUX\_LD\_PREV

Similar than the `mux_map_prev` instruction, but only the index pointer will be set to point to the previous row i.e. no mapping will be set and the engine-to-LED-driver connection will not be updated.

**COMPILER COMMAND SYNTAX:** *MLP;*

This command doesn't support any parameters.

### 8.13.10 MUX\_MAP\_ADDR

`Mux_map_addr` sets the index pointer to point the mapping table row defined by bits [6:0] and sets the row active. Engine will not push a new PWM value to the LED driver output before `set_pwm` or `ramp` instruction is executed. If the mapping has been released from an LED, the value in the PWM register will still control the LED brightness. If the mapping is released from the GPO pin, serial bus control takes over the GPO state

**COMPILER COMMAND SYNTAX:** *MMA, SRAM address[7];*

Table 84. MMA Parameter Description

Name	Value	Description
SRAM address	0-95	Any SRAM address containing mapping data.

#### 8.13.10.1 MMA Application Example

In this example we assume the we have already defined the start and end address of the LED mapping table. Now we want to set address 83d within the address range of the map table active.

**COMPILER COMMAND SYNTAX EXAMPLE:** *MMA, 83;*

### 8.13.11 MUX\_LD\_ADDR

`Mux_ld_addr` sets the index pointer to point the mapping table row defined by bits [6:0], but the row will not be set active.

**COMPILER COMMAND SYNTAX:** *MLA, SRAM address;*

Table 85. MLA Parameter Description

Name	Value	Description
SRAM address	0-95	Any SRAM address containing mapping data.

## 8.14 Branch Instructions

### 8.14.1 RST

RST instruction resets Program Counter register (address 37H, 38H, or 39H) and continues executing the program from the program start address defined in 4C-4E. Instruction takes sixteen 32 kHz clock cycles.

**COMPILER COMMAND SYNTAX:** *RST;*

This command doesn't support any parameters.

**Note:** The default value for all program memory registers is 0000H, which is the RST instruction.

### 8.14.2 BRANCH (Numerical)

Branch instruction is mainly indented for repeating a portion of the program code several times. Branch instruction loads step number value to program counter. Loop count parameter defines how many times the instructions inside the loop are repeated. AS3661 supports nested looping i.e. loop inside loop. The number of nested loops is not limited. Instruction takes sixteen 32 kHz clock cycles.

**COMPILER COMMAND SYNTAX:** *BRN, loop count[6], step number[7];*

Table 86. BRN Parameter Description

Name	Accepted Value	Description
loop count	0-63	The number of loops to be done. 0 means an infinite loop
step number	0-95	The step number to be loaded to program counter

#### 8.14.2.1 BRN Application Example

In this application example we would like to create an infinite loop, which means the loop will never stop. The code we want to repeat has a start address of 10d. At the end of the code we want to repeat we put the BRN command with the program counter address 10d. Once the program execution engine executes the BRN command the program counter jumps back to address 10d and starts executing the code from this address until it reaches again the BRN command.

**COMPILER COMMAND SYNTAX: EXAMPLE:** *BRN, 0, 10;*

Figure 35. BRN Example for execution engine 1

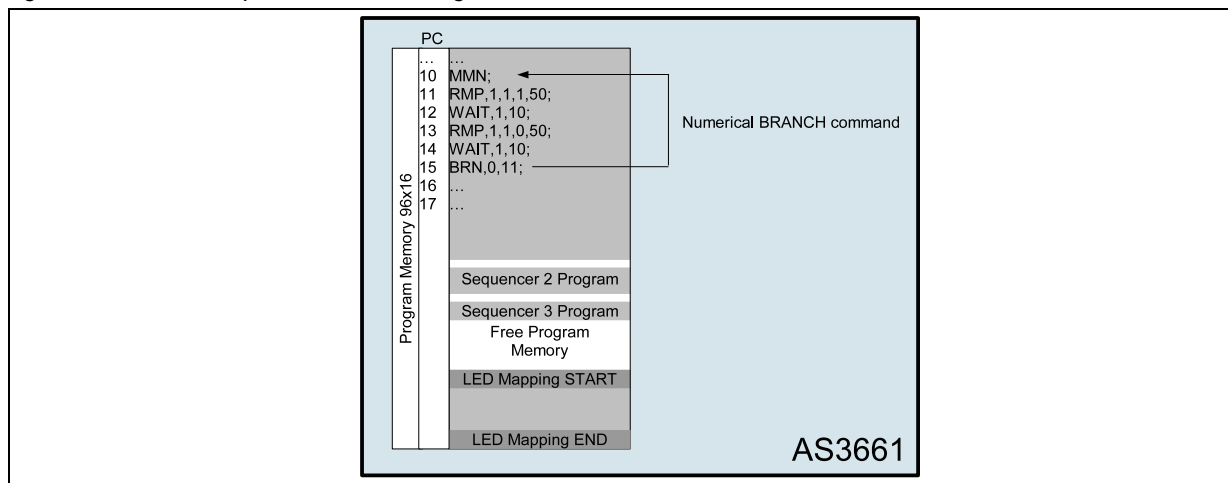

### 8.14.3 BRANCH (Variables)

The BRANCH command for variables has basically the same functionality like the numerical command. The only difference is that the loop count is controlled with variables instead of having a fixed number.

**COMPILER COMMAND SYNTAX:** *BRV, step number[7], loop count[2];*

Table 87. BRN Parameter Description

Name	Accepted Value	Description	
step number	0-95	The step number to be loaded to program counter	
loop count	0-3	Selects the variable for step number value. Step number is loaded with the value of the variable defined below	
		0	local variable A
		1	local variable B
		2	local variable C
	3	register address 3CH variable D value, or register address 42H value	

### 8.14.4 INT

Send interrupt to processor by pulling the INT pin down and setting corresponding status bit high. Interrupt can be cleared by reading interrupt bits in STATUS/INTERRUPT register at address 3A.

**COMPILER COMMAND SYNTAX:** *INT;*

This command doesn't support any parameters.

### 8.14.5 END

End program execution. Instruction takes sixteen 32 kHz clock cycles.

**COMPILER COMMAND SYNTAX:** *END, int[1], Reset[1];*

Table 88. END Parameter Description

Name	Value	Description
int	0	No interrupt will be sent. PWM register values will remain intact.
	1	Reset program counter value to 0 and send interrupt to processor by pulling the INT pin down and setting corresponding status bit high to notify that program has ended. PWM register values will remain intact. Interrupt can be cleared by reading interrupt bits in STATUS/INTERRUPT register at address 3A.
Reset	0	Reset program counter value to 0 and hold. PWM register values will remain intact.
	1	Reset program counter value to 0 and hold. PWM register values of the non-mapped drivers will remain. PWM register values of the mapped drivers will be set to "0000 0000". On completion of int instruction with this bit set to "1" the master fader registers are set to zero as follows: Program execution engine 1 sets MASTER FADER 1 (48H) to zero, engine 2 sets MASTER FADER 2 (49H) to zero and engine 3 sets MASTER FADER 3 (4AH) to zero.

#### 8.14.5.1 END Application Example

The example code below sends an interrupt to the processor and resets the program counts to 0. The program execution engine is set on hold.

**COMPILER COMMAND SYNTAX EXAMPLE:** *END, 1, 0;*

### 8.14.6 TRIGGER

Wait or send triggers can be used to e.g. synchronize operation between the program execution engines. Send trigger instruction takes sixteen 32 kHz clock cycles and wait for trigger takes at least sixteen 32 kHz clock cycles. The receiving engine stores the triggers which have been sent. Received triggers are cleared by wait for trigger instruction. Wait for trigger instruction is executed until all the defined triggers have been received (note: several triggers can be defined in the same instruction).

External trigger input signal must stay low for at least two 32 kHz clock cycles to be executed. Trigger output signal is three 32 kHz clock cycles long. External trigger signal is active low, i.e. when trigger is send/received the pin is pulled to GND. Sent external trigger is masked, i.e. the device which has sent the trigger will not recognize it. If send and wait external trigger are used on the same instruction, the send external trigger is executed first, then the wait external trigger.

**COMPILER COMMAND SYNTAX:** *TRG, wait for trigger[6], send a trigger[6]*

Table 89. TRG Parameter Description

Name	Value	Description
wait for trigger	0-31	Wait for trigger from the engine(s). Several triggers can be defined in the same instruction. Bit [7] engages engine 1, bit [8] engine 2, bit [9] engine 3 and bit [12] is for external trigger I/O. Bits [10] and [11] are not in use.
send a trigger	0-31	Send a trigger to the engine(s). Several triggers can be defined in the same instruction. Bit [1] engages engine 1, bit [2] engine 2, bit [3] engine 3 and bit [6] is for external trigger I/O. Bits [4] and [5] are not in use.

#### 8.14.6.1 TRG Application Example

In this example we want to wait/receive a trigger from program execution engine 1.

**COMPILER COMMAND SYNTAX EXAMPLE:** *TRG, 2, 0;*

#### 8.14.7 JNE/JL/JGE/JE

AS3661 instruction set includes the following conditional jump instructions: jne (jump if not equal); jge (jump if greater or equal); jl (jump if less); je (jump if equal). If the condition is true a certain number of instructions will be skipped (i.e. the program jumps forward to a location relative to the present location). If condition is false then the next instruction will be executed.

**COMPILER COMMAND SYNTAX:** *JNE, number of instructions...[5], Variable1[2], Variable2[2];*

**COMPILER COMMAND SYNTAX:** *JL, number of instructions...[5], Variable1[2], Variable2[2];*

**COMPILER COMMAND SYNTAX:** *JGE, number of instructions...[5], Variable1[2], Variable2[2];*

**COMPILER COMMAND SYNTAX:** *JE, number of instructions...[5], Variable1[2], Variable2[2];*

Table 90. JNE/JL/JGE/JE Parameter Description

Name	Value	Description	
number of instructions to be skipped if the operation returns true.	0-31	The number of instructions to be skipped when the statement is true. Note: value 0 means redundant code.	
Variable1	0-3	Defines the variable to be used in the test:	
		0	local variable A
		1	local variable B
		2	global variable
	C3	register address 3CH variable, or register address 42H value	
Variable2	0-3	Defines the variable to be used in the test:	
		0	local variable A
		1	local variable B
		2	global variable
	C3	register address 3CH variable, or register address 42H value	

#### 8.14.7.1 JNE Application Example

In the following example we compare local variable A with local variable B. If the value of the two registers is not equal the command will skip three instructions.

**COMPILER COMMAND SYNTAX EXAMPLE:** *JNE, 3, 0, 1;*

## 8.15 Arithmetic Instructions

### 8.15.1 LD

This instruction is used to assign a value into a variable; the previous value in that variable is overwritten. Each of the engines have two local variables, called A and B. The variable C is a global variable which is shared with all three program execution engines.

**COMPILER COMMAND SYNTAX:** *LD, Target Variable[2];*

Table 91. LD Parameter Description

Name	Value	Description	
Target Variable	0-2	0	variable A
		1	variable B
		2	variable C
8-bit value	0-255	variable value	

#### 8.15.1.1 LD Application Example

In this example we want to load variable B with a value of 100;

**COMPILER COMMAND SYNTAX EXAMPLE:** *LD, 1, 100;*

### 8.15.2 ADD (Numerical Operands)

Operator either adds the 8-bit value to the current value of the target variable.

**COMPILER COMMAND SYNTAX:** *ADN, Target Variable,[2], 8-Bit value[8];*

Table 92. ADN Parameter Description

Name	Value	Description	
8-bit value	0-255	Variable value	
Target Variable	0-2	0	variable A
		1	variable B
		2	variable C
Variable1	0-3	0	local variable A
		1	local variable B
		2	global variable
		C3	register address 3CH variable, or register address 42H value
Variable2	0-3	0	local variable A
		1	local variable B
		2	global variable
		C3	register address 3CH variable, or register address 42H value

#### 8.15.2.1 ADN Application Example

In this example we would like to add a value of 100d to variable 'A', which is loaded with a value of 10d. The result of the operation is 110d stored in variable 'A'.

**COMPILER COMMAND SYNTAX EXAMPLE:** *ADN, 0, 100;*

### 8.15.3 ADD (Variables)

This command adds the value of the variable 1 (A, B, C or D) to the value of the variable 2 (A, B, C or D) and stores the result in the register of variable A, B or C which is defined as target variable. Variables overflow from 255 to 0.

**COMPILER COMMAND SYNTAX:** *ADV, Target Variable[2], Variable1[2], Variable2[2];*

Table 93. ADV Parameter Description

Name	Value	Description	
Target Variable	0-2	0	variable A
		1	variable B
		2	variable C
Variable1	0-3	0	local variable A
		1	local variable B
		2	global variable
		C3	register address 3CH variable, or register address 42H value
Variable2	0-3	0	local variable A
		1	local variable B
		2	global variable
		C3	register address 3CH variable, or register address 42H value

### 8.15.3.1 ADV Application Example

In this example we want to add variable 'A' to variable 'B'. The result should be stored in variable 'C'.

**COMPILER COMMAND SYNTAX EXAMPLE:** *ADV, 2, 0, 1;*

### 8.15.4 SUB (Numerical)

SUB Operator either subtracts the 8-bit value from the current value of the target variable.

**COMPILER COMMAND SYNTAX:** *SBN, Target Variable[2], 8-bit value[8];*

Table 94. SBN Parameter Description

Name	Value	Description	
8-bit value	0-255	variable value	
Target Variable	0-2	0	variable A
		1	variable B
		2	variable C

### 8.15.4.1 SBN Application Example

In this example we would like to subtract 50d from local variable 'A'. The result is stored in variable 'A'.

**COMPILER COMMAND SYNTAX EXAMPLE:** *SBN, 0, 50;*

### 8.15.5 SUB (Variables)

The SBV command subtracts the value of the variable 2 (A, B, C or D) from the value of the variable 1 (A, B, C or D) and stores the result in the register of target variable (A, B or C). Variables overflow from 0 to 255.

**COMPILER COMMAND SYNTAX:** *SBV, Target Variable[2], Variable1[2], Variable2[2];*

Table 95. SBV Parameter Description

Name	Value	Description	
Target Variable	0-2	0	variable A
		1	variable B
		2	variable C

Table 95. SBV Parameter Description

Name	Value	Description	
Variable1	0-3	0	local variable A
		1	local variable B
		2	global variable
		C3	register address 3CH variable, or register address 42H value
Variable2	0-3	0	local variable A
		1	local variable B
		2	global variable
		C3	register address 3CH variable, or register address 42H value

#### 8.15.5.1 SBV Application Example

In this example we would like to subtract variable 'A' from variable 'B'. The result should be stored in variable 'C'.

**COMPILER COMMAND SYNTAX EXAMPLE:** `SBV, 2, 0, 1;`



# 9 Typical Application

Figure 36. Typical Application 3 RGB LEDs

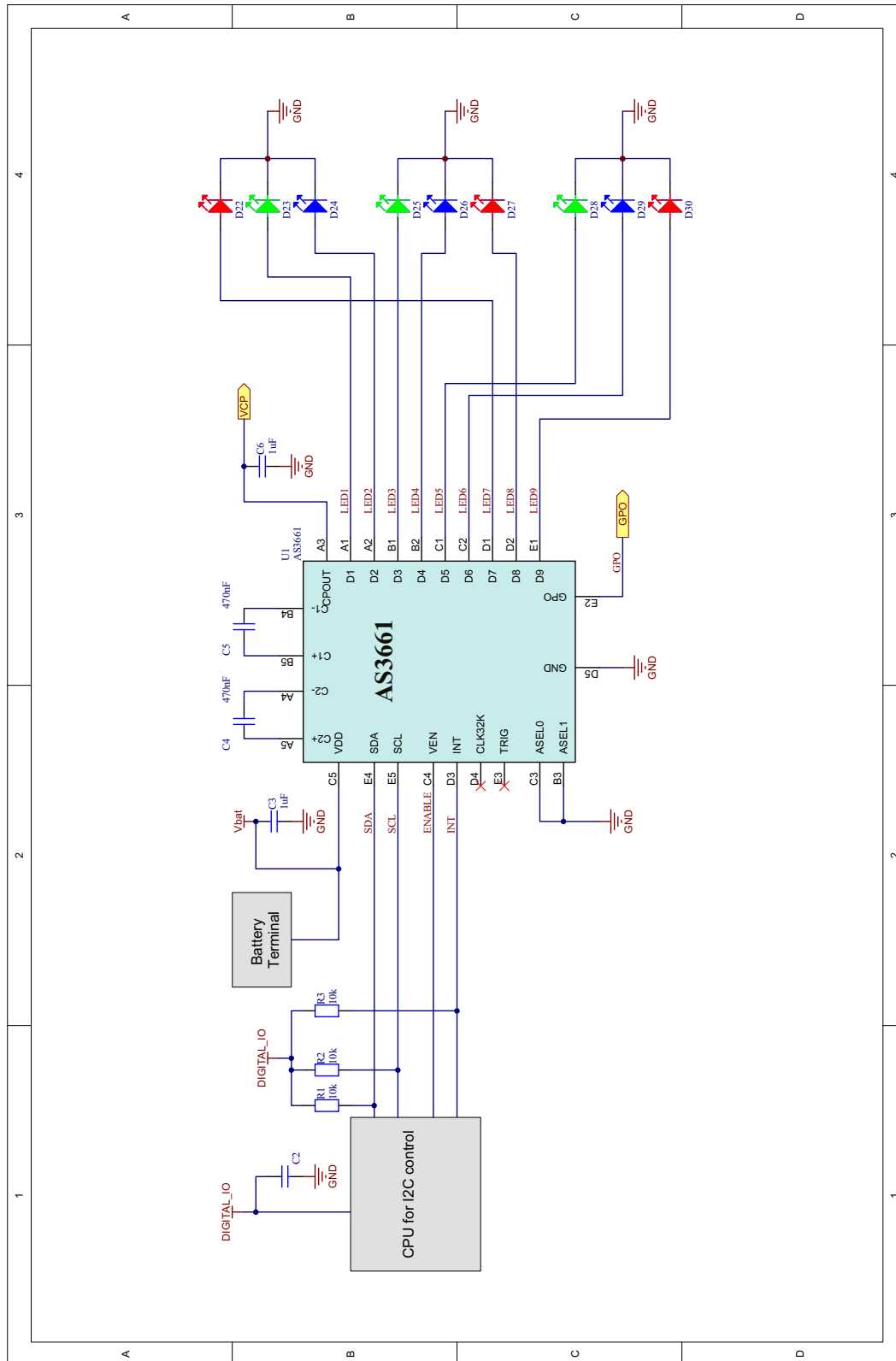

## 9.1 Recommended External Components

The AS3661 requires 4 external capacitors for proper operation. Surface-mount multi-layer ceramic capacitors are recommended. Tantalum and aluminium capacitors are not recommended because of their high ESR. For the flying capacitors (C1 and C2) multi-layer ceramic capacitors should always be used. These capacitors are small, inexpensive and have very low equivalent series resistance (ESR <20mΩ typ.). Ceramic capacitors with X7R or X5R temperature characteristic are preferred for use with the AS3661. These capacitors have tight capacitance tolerance (as good as ±10%) and hold their value over temperature (X7R: ±15% over -55°C to 125°C; X5R: ±15% over -55°C to 85°C). Capacitors with Y5V or Z5U temperature characteristic are generally not recommended for use with the AS3661. Capacitors with these temperature characteristics typically have wide capacitance tolerance (+80%, -20%) and vary significantly over temperature (Y5V: +22%, -82% over -30°C to +85°C range; Z5U: +22%, -56% over +10°C to +85°C range). Under some conditions, a nominal 1µF Y5V or Z5U capacitor could have a capacitance of only 0.1µF. Such detrimental deviation is likely to cause Y5V and Z5U capacitors to fail to meet the minimum capacitance requirements of the AS3661. For proper operation it is necessary to have at least 0.24 µF of effective capacitance for each of the flying capacitors under all operating conditions. The output capacitor CVCPOUT directly affects the magnitude of the output ripple voltage. In general, the higher the value of CVCPOUT, the lower the output ripples magnitude. For proper operation it is recommended to have at least 0.50µF of effective capacitance for CVBAT and CVCPOUT under all operating conditions. The voltage rating of all four capacitors should be 6.3V; 10V is recommended. Recommended External Components below lists recommended external components from some leading ceramic capacitor manufacturers. It is strongly recommended that the AS3661 circuit be thoroughly evaluated early in the design-in process with the mass-production capacitors of choice. This will help ensure that any variability in capacitance does not negatively impact circuit performance.

Figure 37. Recommended External Components

Model	Type	Vendor	Voltage Rating	Package Size
1µF for CVBAT and CVCPOUT				
C1005X5R1A105K	Ceramic X5R	TDK	10V	0402
LMK105BJ105KV-F	Ceramic X5R	Taiyo Yuden	10V	0402
ECJ0EB1A105M	Ceramic X5R	Panasonic	10V	0402
ECJUVBPA105	Ceramic X5R, array of two	Panasonic	10V	0504
470F for CFLY1 and CFLY2				
C1005X5R1A474K	Ceramic X5R	TDK	10V	0402
LMK105BJ474KV-F	Ceramic X5R	Taiyo Yuden	10V	0402
ECJ0EB0J474K	Ceramic X5R	Panasonic	6.3V	0402
LEDs		User defined. Note that D7, D8 and D9 outputs are powered from VBAT when specifying the LEDs.		

# 10 Package Drawings and Markings

Figure 38. WL-CSP-25 (2.285x2.285mm) 0.4mm pitch Marking

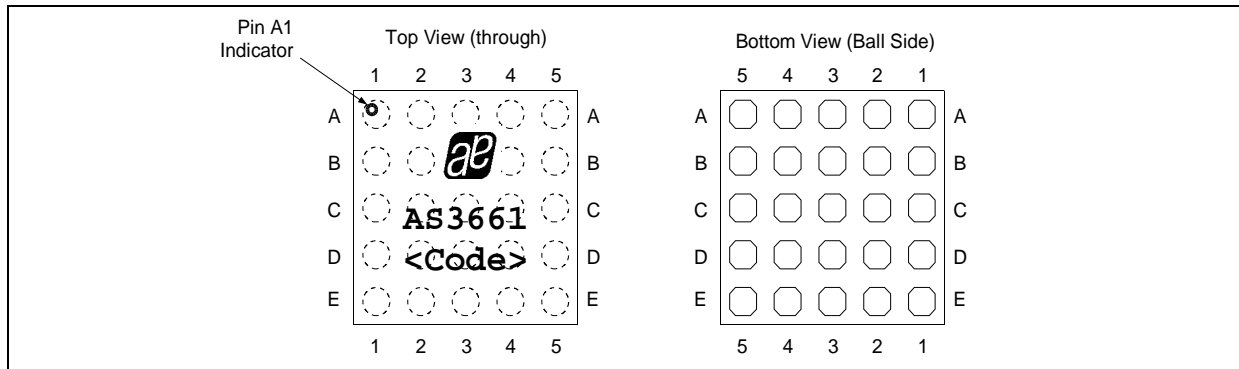

**Note:**

- Line 1: austriamicrosystems logo
- Line 2: AS3661
- Line 3: <Code>  
Encoded Datecode (4 characters)

Figure 39. WL-CSP-25 (2.285x2.285mm) 0.4mm pitch Package Dimensions

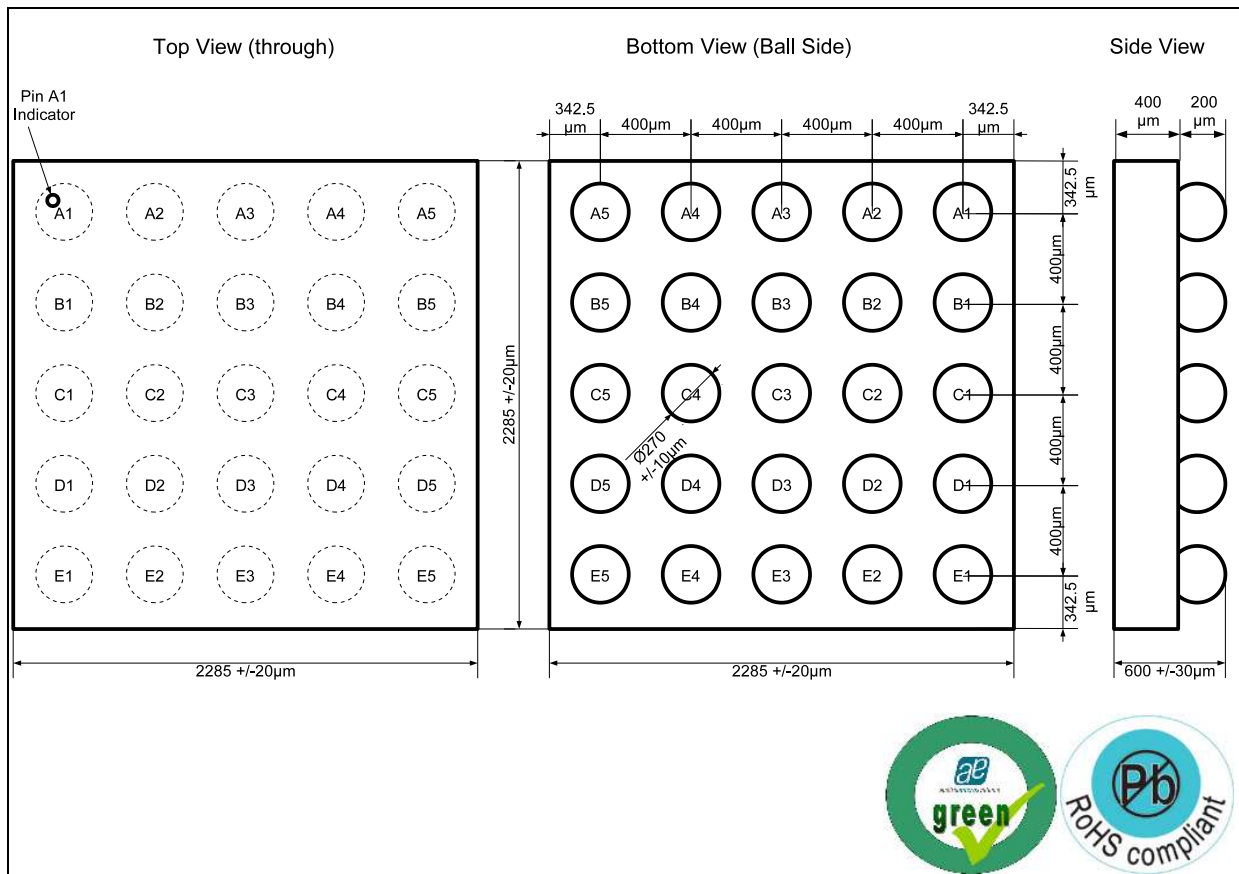

## 11 Ordering Information

The devices are available as the standard products shown in [Table 96](#).

*Table 96. Ordering Information*

Ordering Code	Marking	Description	Delivery Form	Package
AS3661-BWLT	AS3661	Programmable 9-channel LED Driver	Tape and Reel	WL-CSP-25 (2.285x2.285mm) 0.4mm pitch

**Note:** All products are RoHS compliant and austriamicrosystems green.  
Buy our products or get free samples online at ICdirect: <http://www.austriamicrosystems.com/ICdirect>

Technical Support is found at <http://www.austriamicrosystems.com/Technical-Support>

For further information and requests, please contact us <mailto:sales@austriamicrosystems.com>  
or find your local distributor at <http://www.austriamicrosystems.com/distributor>

## Copyrights

Copyright © 1997-2012, austriamicrosystems AG, Tobelbaderstrasse 30, 8141 Unterpremstaetten, Austria-Europe. Trademarks Registered ®. All rights reserved. The material herein may not be reproduced, adapted, merged, translated, stored, or used without the prior written consent of the copyright owner.

All products and companies mentioned are trademarks or registered trademarks of their respective companies.

## Disclaimer

Devices sold by austriamicrosystems AG are covered by the warranty and patent indemnification provisions appearing in its Term of Sale. austriamicrosystems AG makes no warranty, express, statutory, implied, or by description regarding the information set forth herein or regarding the freedom of the described devices from patent infringement. austriamicrosystems AG reserves the right to change specifications and prices at any time and without notice. Therefore, prior to designing this product into a system, it is necessary to check with austriamicrosystems AG for current information. This product is intended for use in normal commercial applications. Applications requiring extended temperature range, unusual environmental requirements, or high reliability applications, such as military, medical life-support or life-sustaining equipment are specifically not recommended without additional processing by austriamicrosystems AG for each application. For shipments of less than 100 parts the manufacturing flow might show deviations from the standard production flow, such as test flow or test location.

The information furnished here by austriamicrosystems AG is believed to be correct and accurate. However, austriamicrosystems AG shall not be liable to recipient or any third party for any damages, including but not limited to personal injury, property damage, loss of profits, loss of use, interruption of business or indirect, special, incidental or consequential damages, of any kind, in connection with or arising out of the furnishing, performance or use of the technical data herein. No obligation or liability to recipient or any third party shall arise or flow out of austriamicrosystems AG rendering of technical or other services.



## Contact Information

Headquarters

austriamicrosystems AG  
Tobelbaderstrasse 30  
A-8141 Unterpremstaetten, Austria

Tel: +43 (0) 3136 500 0

Fax: +43 (0) 3136 525 01

For Sales Offices, Distributors and Representatives, please visit:

<http://www.austriamicrosystems.com/contact>