

REVISIONS					
P	LTR	DESCRIPTION	DATE	DWN	APVD
E2		REVISED PER ECO-11-005030	11MAR2011	RK	HMR
E3		REVISED PER PCN-22-148530	27JUL2022	SN	FC

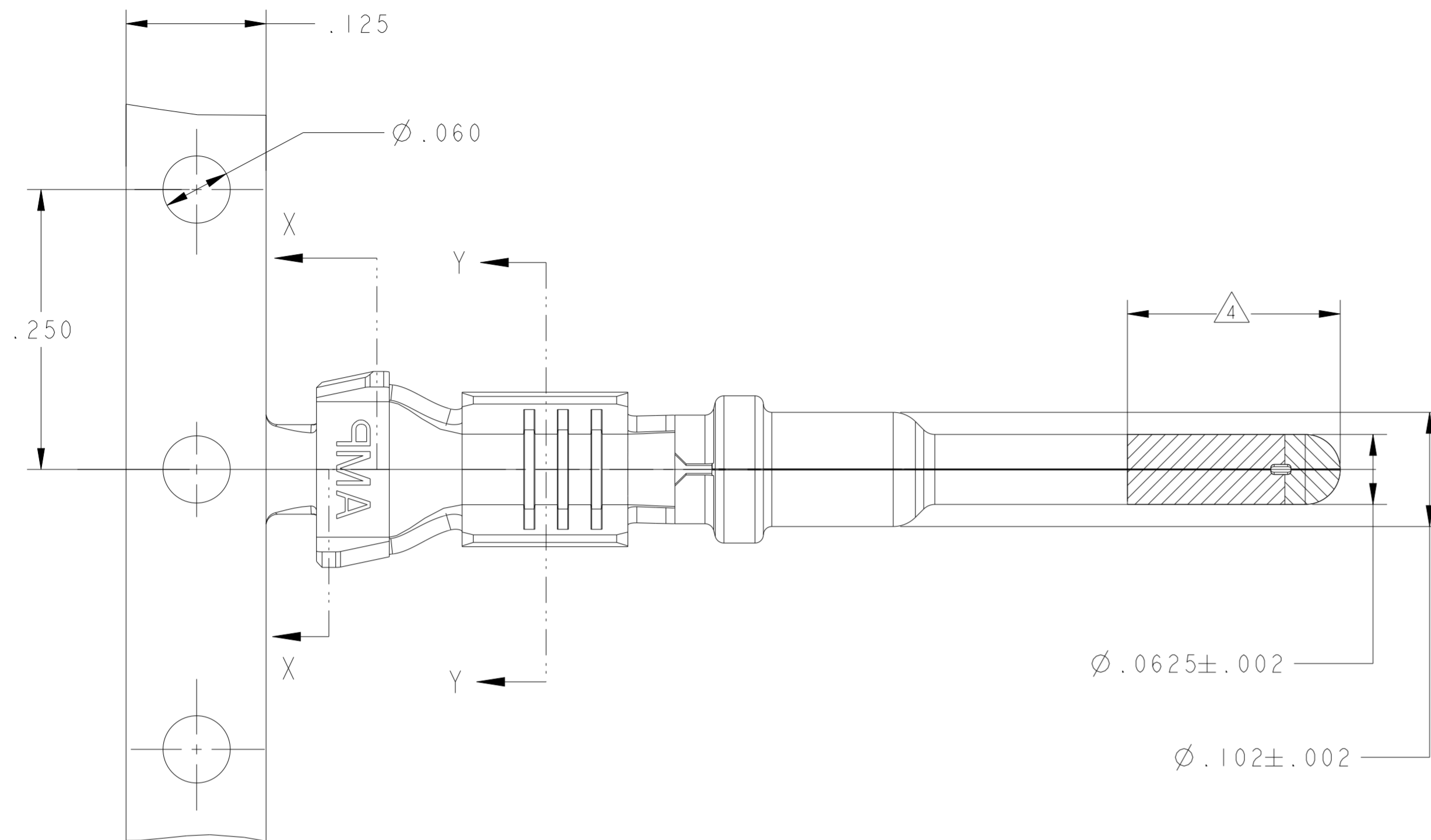

- 1. FINISH : PLATE 0.000100-0.000200 THK TIN IN LOCALIZED TIN PLATE AREA ALL OVER
0.000040-0.000080 THK NICKEL.
 - 2. CONTACT WILL BE LUBED WITH LUBRICANT PER P/N 22014-4.
 - 3. WIRE RANGE: 18-14 AWG GLX AND 18-16 AWG SXL WIRE WITH INSL DIAMETERS OF 0.089-0.131 INCHES.
4. PLATE 0.000030 MIN THK SELECT GOLD IN LOCALIZED PLATE AREA.

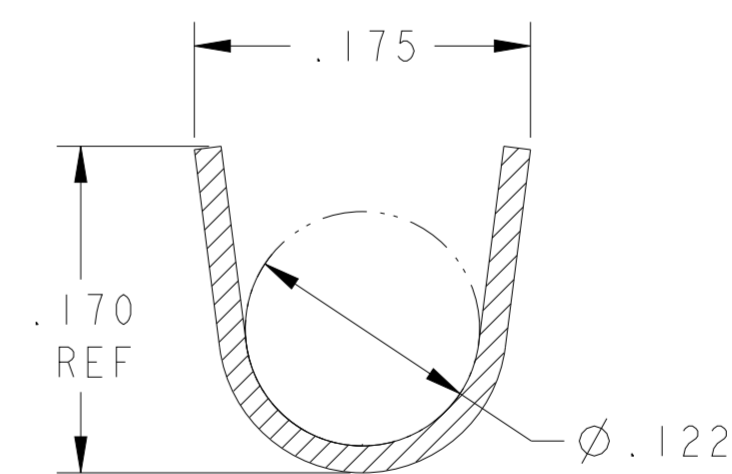
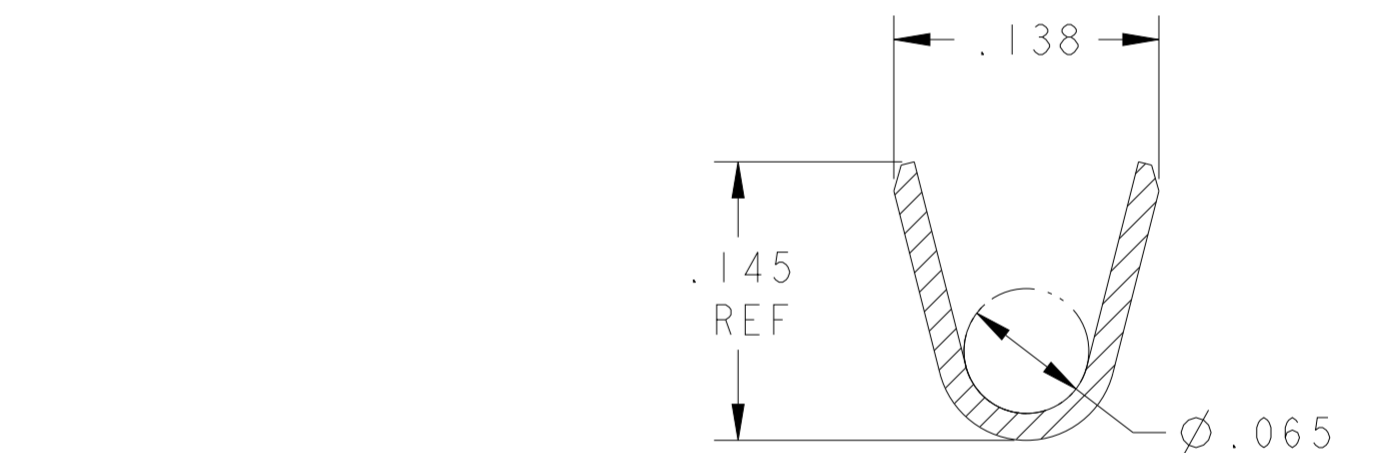
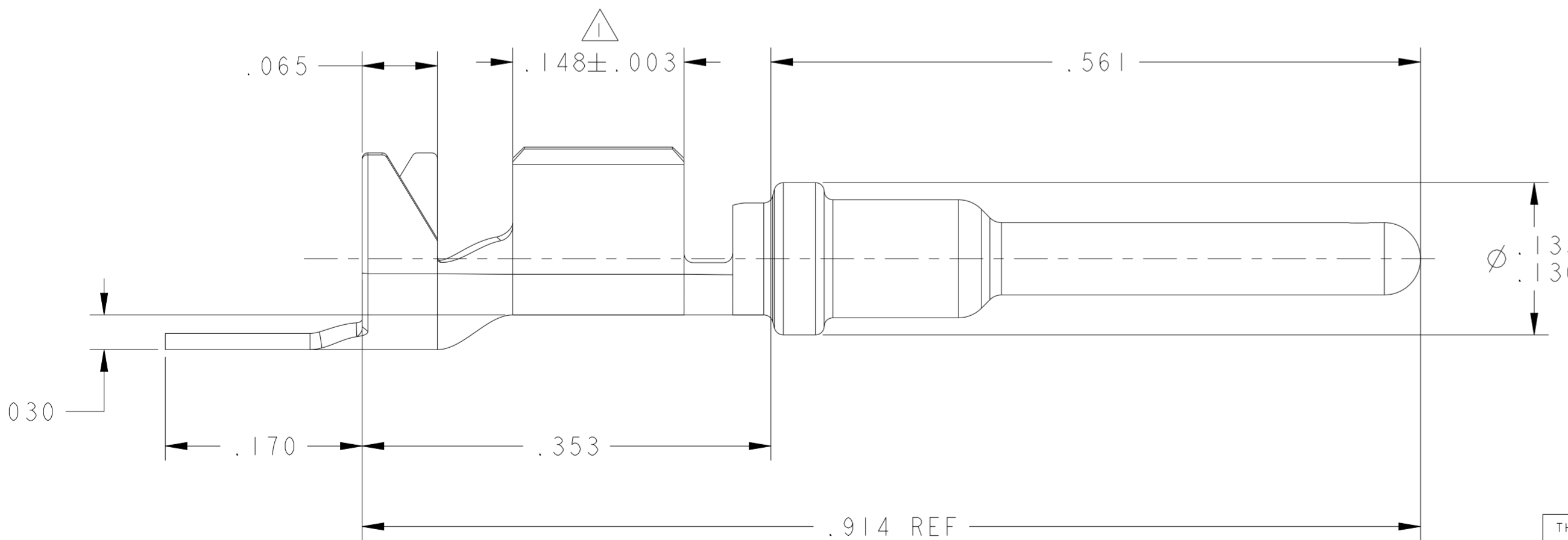

	638078-3
	638078-1
FINISH	PART NUMBER

THIS DRAWING IS A CONTROLLED DOCUMENT.		DWN P. YEAGER	13JUN1997	TE Connectivity	
DIMENSIONS: INCHES		CHK W. LONG	13JUN1997		
TOLERANCES UNLESS OTHERWISE SPECIFIED:		APVD W. LONG	13JUN1997	NAME PIN CONTACT	
0 PLC ±		PRODUCT SPEC		-	
1 PLC ±		APPLICATION SPEC		-	
2 PLC ±.02		WEIGHT		-	
3 PLC ±.005		CUSTOMER DRAWING		SCALE 10:1 SHEET 1 OF 1 REV E3	
4 PLC ±		SIZE		A200779	
ANGLES ±		CAGE CODE		G-638078	
FINISH		DRAWING NO		-	
MATERIAL 0.014 TK CU ALLOY		RESTRICTED TO		-	