

LOC	DIST	REVISIONS					
		P	LTR	DESCRIPTION	DATE	DWN	APVD
A1	-		A13	REVISED PER ECR-22-171640	31AUG2022	TDB	KR

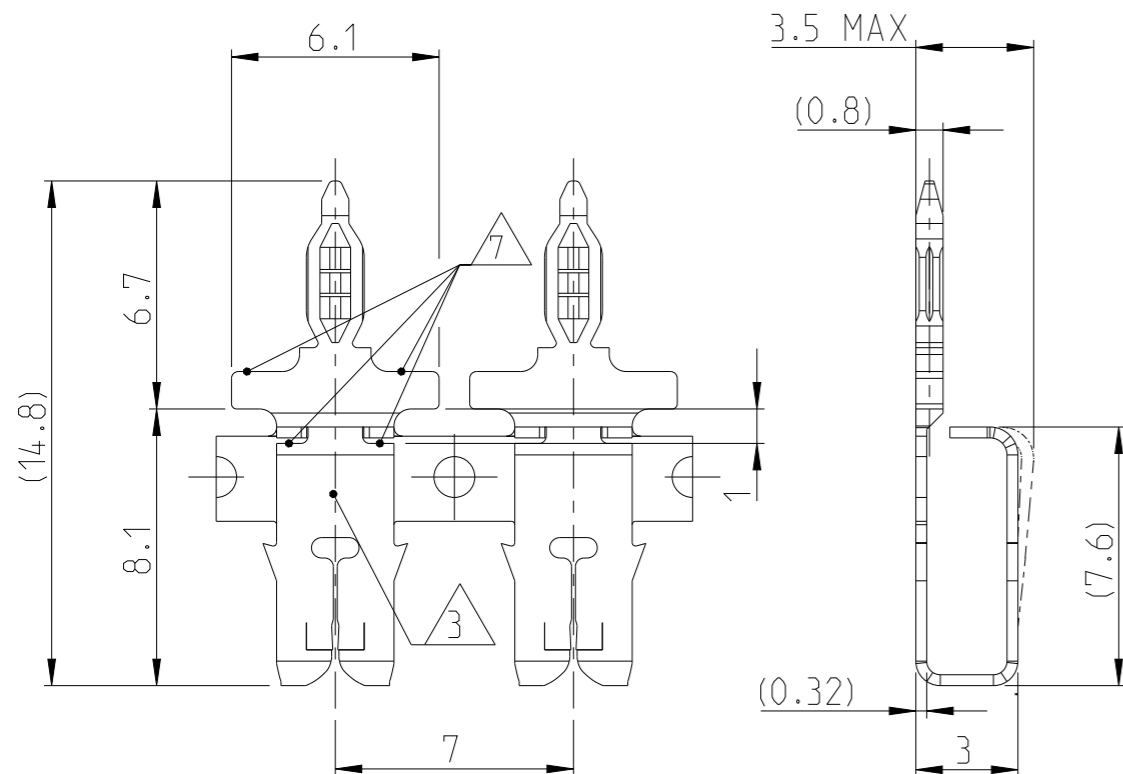

- 1 SLOT ACCEPTS SINGLE OR DOUBLE COPPER MAGNET WIRE (SEE TABLE) NOT FOR USE WITH ALUMINUM MAGNET WIRE.
- 2 SLOT ACCEPTS SINGLE OR DOUBLE ALUMINUM MAGNET WIRE (SEE TABLE)
- 3 IDENTIFICATION NUMBER FOR MAGNET WIRE RANGE
- 4 CONTACT CAVITY AND APPLICATION ACC. SPECIFICATION 114-74109. (SEE TABLE)
- 5 PCB LAYOUT (HOLES ACC. SPECIFICATION. 108-90801)
- 6 CUTTING LINE: AREA WILL BE CUTTED OFF BY TERMINATION
- 7 AREA FOR INSERTION TOOL
- 8 DELIVERY STATE: STRIP ON CORRUGATED REEL WITH PAPER INTERLAYER
- 9 To Be APPROVED, ON DEMAND BY TE ENGINEERING
- 10 MAX.2 SPLICES PER REEL; SPLICES BE NOT BONDED TOGETHER
- 11 SPECIAL CAVITY ANVIL LOCATION .190in [4.83mm] REQUIRED. REF APPLICATION SPEC 114-2046, PAGE 4, NOTE 7.

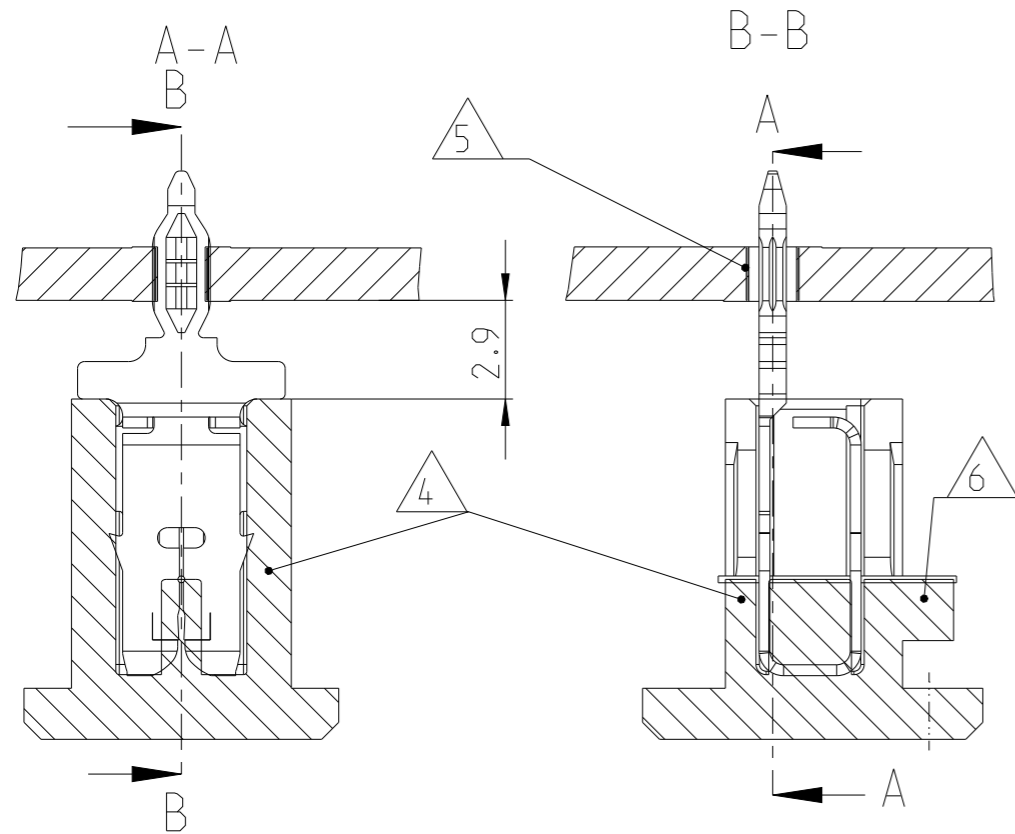
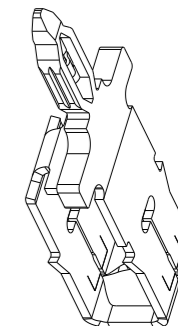

DIRECTION OFF TOP OF REEL	FIG	AWG BARE WIRE RANGE	PLC	PLC	BARE WIRE RANGE	REV	PART NO
DIRECTION OFF TOP OF REEL FIG 273	33	-	15 - 16	-	Ø1.30mm to Ø1.45mm	A	2238145-2
		-	16.5 - 16	-	Ø1.20mm to Ø1.30mm	A	2238145-1
DIRECTION OFF TOP OF REEL FIG 272	24	-	19.5 - 17	-	Ø 0.85mm to Ø 1.15mm	A	1247004-2
		-	19.5 - 17.5	17	Ø 0.85mm to Ø 1.12mm	A	1247004-1
	16	23-20	23-20	Ø 0.56mm to Ø 0.81mm	1	2238306-1	
	12	-	22 - 18.75	-	Ø 0.63mm to Ø 0.95mm	A	1247003-2
		-	22.5 - 20	19.5	Ø 0.63mm to Ø 0.85mm	A	1247003-1
	10	24 - 22	24 - 22	Ø 0.51mm to Ø 0.64mm	Ø 0.51mm to Ø 0.64mm	A	1247002-2
		26 - 23	26 - 22.5	Ø 0.40mm to Ø 0.56mm	Ø 0.40mm to Ø 0.63mm	A	1247002-1
	6	28 - 25	28 - 25	Ø 0.32mm to Ø 0.45mm	Ø 0.32mm to Ø 0.45mm	A	1247001-2
		29.5 - 26.5	29.5 - 26.5	Ø 0.265mm to Ø 0.4mm	Ø 0.265mm to Ø 0.4mm	A	1247001-1
	4	33 - 30	33 - 30	Ø 0.18mm to Ø 0.265mm	Ø 0.18mm to Ø 0.265mm	A	1247000-2
		DOUBLE WIRE	SINGLE WIRE	DOUBLE WIRE	SINGLE WIRE		
		AWG BARE WIRE RANGE		BARE WIRE RANGE		REV	PART NO

THIS DRAWING IS A CONTROLLED DOCUMENT.		DWN H.Ballmert 04 JUN2012	TE Connectivity	
DIMENSIONS: mm		CHK B.Schnaubelt 04 JUN2012		
TOLERANCES UNLESS OTHERWISE SPECIFIED:		APVD T.Klenner 04 JUN2012	NAME	
0 PLC ± 1 PLC ± 2 PLC ± 3 PLC ± 4 PLC ± ANGLES ±1°		PRODUCT SPEC 108-74116	MAG-MATE 300 SERIES WITH MULTISPRING	
MATERIAL COPPER ALLOY		FINISH POSTTINNED	APPLICATION SPEC 114-74109	RESTRICTED TO
		WEIGHT 0.25g/prt	SIZE A3	CAGE CODE 00779
		CUSTOMER DRAWING	DRAWING NO C-1247000	SCALE 5:1
			SHEET 1 OF 1	REV A13