



18 Output, 3.3V SDRAM Buffer for Desktop PCs with 4 DIMMs

Features

- One input to 18 output buffer/driver
- Supports up to four SDRAM DIMMs
- Two additional outputs for feedback
- SMBus interface for individual output control
- Low skew outputs (< 200 ps)
- Up to 100 MHz operation for Industrial temperatures
- Up to 133 MHz operation for Commercial temperatures
- Dedicated OE pin for testing
- Space-saving 48-pin SSOP package
- 3.3V operation

Functional Description

The CY2318BNZ is a 3.3V buffer designed to distribute high-speed clocks in PC applications. The part has 18 outputs, 16 of which can be used to drive up to four SDRAM DIMMs, and the remaining can be used for external feedback to a PLL. The device operates at 3.3V and outputs can run up to 100 MHz, thus making it compatible with Pentium II® processors. The CY2318BNZ can be used in conjunction with the CY2280, CY2281, CY2282 or similar clock synthesizer for a complete Pentium II motherboard solution.

The CY2318BNZ also includes an SMBus interface which can enable or disable each output clock. On power-up, all output clocks are enabled (internal pull up). A separate Output Enable pin facilitates testing on ATE.

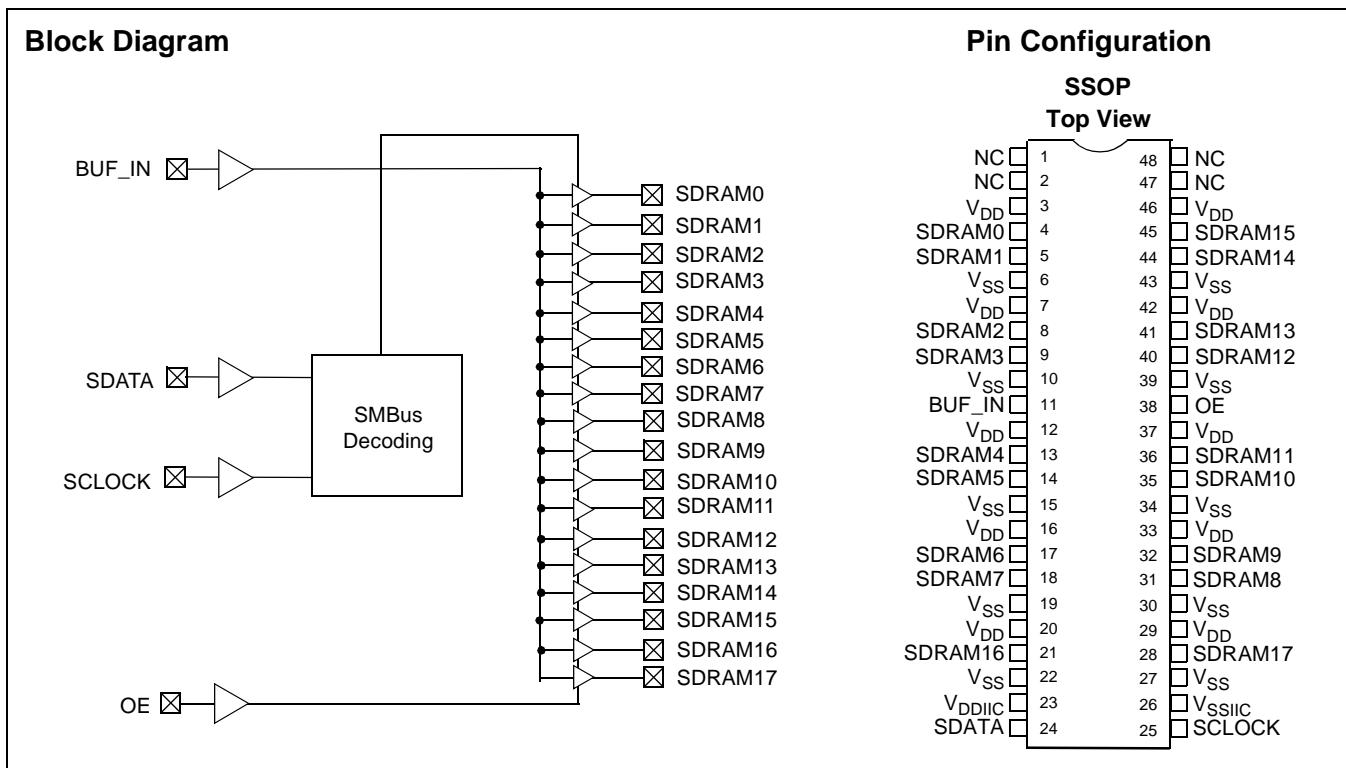

Pentium II is a registered trademark of Intel Corporation.

Pin Summary

Name	Pins	Description
V _{DD}	3, 7, 12, 16, 20, 29, 33, 37, 42, 46	3.3V Digital voltage supply
V _{SS}	6, 10, 15, 19, 22, 27, 30, 34, 39, 43	Ground
V _{DDIIC}	23	SMBus Voltage supply
V _{SSIIC}	26	Ground for SMBus
BUF_IN	11	Input clock (5V tolerant)
OE	38	Output Enable (active HIGH), Three-state outputs when LOW ^[1]
SDATA	24	SMBus data input ^[1]
SCLK	25	SMBus clock input ^[1]
SDRAM [0–3]	4, 5, 8, 9	SDRAM byte 0 clock outputs
SDRAM [4–7]	13, 14, 17, 18	SDRAM byte 1 clock outputs
SDRAM [8–11]	31, 32, 35, 36	SDRAM byte 2 clock outputs
SDRAM [12–15]	40, 41, 44, 45	SDRAM byte 3 clock outputs
SDRAM [16–17]	21, 28	SDRAM clock outputs usable for feedback
N/C	1, 2, 47, 48	Reserved for future modifications, do not connect in system

Note:

1. Internal pull-up resistor to V_{DD} (value > 100 kohms).

Device Functionality

OE	SDRAM [0–17]
0	Hi-Z
1	1 x BUF_IN

Serial Configuration Map

- The Serial bits will be read by the clock driver in the following order:
 - Byte 0 - Bits 7, 6, 5, 4, 3, 2, 1, 0
 - Byte 1 - Bits 7, 6, 5, 4, 3, 2, 1, 0
 - ...
 - Byte N - Bits 7, 6, 5, 4, 3, 2, 1, 0
- Reserved and unused bits should be programmed to "0".
- SMBus Address for the CY2318BNZ is:

A6	A5	A4	A3	A2	A1	A0	R/W
1	1	0	1	0	0	1	----

Byte 0:SDRAM Active/Inactive Register (1 = Active, 0 = Inactive), Default = Active

Bit	Pin #	Description
Bit 7	18	SDRAM7 (Active/Inactive)
Bit 6	17	SDRAM6 (Active/Inactive)
Bit 5	14	SDRAM5 (Active/Inactive)
Bit 4	13	SDRAM4 (Active/Inactive)
Bit 3	9	SDRAM3 (Active/Inactive)
Bit 2	8	SDRAM2 (Active/Inactive)
Bit 1	5	SDRAM1 (Active/Inactive)
Bit 0	4	SDRAM0 (Active/Inactive)

Maximum Ratings

Supply Voltage to Ground Potential-0.5 to +7.0V
 DC Input Voltage (except BUF_IN)..... -0.5V to $V_{DD} + 0.5$
 DC Input Voltage (BUF_IN)..... -0.5V to 7.0V
 Storage Temperature-65°C to +150°C
 Static Discharge Voltage
 (per MIL-STD-883, Method 3015).....>2000V
 Ambient Temperature under BIAS-55°C to +125°C

Parameter	Description	Rating	Unit
V_{DD}, V_{IN}	Voltage on Any Pin with Respect to GND	-0.5 to +7.0	V
T_{STG}	Storage Temperature	-65 to +150	°C
T_A	Operating Temperature	0 to +70	°C
T_B	Ambient Temperature under Bias	-55 to +125	°C

Operating Conditions

Parameter	Description	Min.	Max.	Unit
V_{DD}, V_{DDIIC}	Supply Voltage	3.135	3.465	V
T_A	Operating Temperature (Ambient Temperature)	-40	85	°C
C_L	Load Capacitance	20	30	pF
C_{IN}	Input Capacitance		7	pF

Byte 1: SDRAM Active/Inactive Register (1 = Active, 0 = Inactive), Default = Active

Bit	Pin #	Description
Bit 7	45	SDRAM15 (Active/Inactive)
Bit 6	44	SDRAM14 (Active/Inactive)
Bit 5	41	SDRAM13 (Active/Inactive)
Bit 4	40	SDRAM12 (Active/Inactive)
Bit 3	36	SDRAM11 (Active/Inactive)
Bit 2	35	SDRAM10 (Active/Inactive)
Bit 1	32	SDRAM9 (Active/Inactive)
Bit 0	31	SDRAM8 (Active/Inactive)

Byte 2: SDRAM Active/Inactive Register (1 = Active, 0 = Inactive), Default = Active

Bit	Pin #	Description
Bit 7	28	SDRAM17 (Active/Inactive)
Bit 6	21	SDRAM16 (Active/Inactive)
Bit 5	--	Reserved, drive to 0
Bit 4	--	Reserved, drive to 0
Bit 3	--	Reserved, drive to 0
Bit 2	--	Reserved, drive to 0
Bit 1	--	Reserved, drive to 0
Bit 0	--	Reserved, drive to 0

Absolute Maximum Ratings

Stresses greater than those listed in this table may cause permanent damage to the device. These represent a stress rating only. Operation of the device at these or any other conditions above those specified in the operating sections of this specification is not implied. Maximum conditions for extended periods may affect reliability.

DC Electrical Characteristics: $T_A = -40^{\circ}\text{C}$ to $+85^{\circ}\text{C}$, $V_{DDQ3} = 3.3\text{V} \pm 5\%$

Parameter	Description	Test Condition/ Comments	Min	Typ	Max	Unit
I_{DD}	3.3V Supply Current	BUF_IN = 64 MHz	140	165	200	mA
$I_{DD \text{ Tristate}}$	3.3V Supply Current in Three-state	BUF_IN = 100 MHz		5		mA
Logic Inputs (BUF_IN, OE, SCLOCK, SDATA)						
V_{IL}	Input Low Voltage		GND-0.3		0.8	V
V_{IH}	Input High Voltage		2.0		$V_{DDQ3} + 0.5$	V
I_{ILEAK}	Input Leakage Current, BUF_IN		-5		+5	μA
I_{ILEAK}	Input Leakage Current ^[2]		-20		+5	μA
Logic Outputs (SDRAM0:17)^[3]						
V_{OL}	Output Low Voltage	$I_{OL} = 1 \text{ mA}$			50	mV
V_{OH}	Output High Voltage	$I_{OH} = -1 \text{ mA}$	3.1			V
I_{OL}	Output Low Current	$V_{OL} = 1.5\text{V}$	70	110	185	mA
I_{OH}	Output High Current	$V_{OH} = 1.5\text{V}$	65	100	160	mA
Pin Capacitance/Inductance						
C_{IN}	Input Pin Capacitance (Except BUF_IN)				5	pF
C_{OUT}	Output Pin Capacitance				6	pF
L_{IN}	Input Pin Inductance				7	nH

AC Electrical Characteristics: $T_A = -40^{\circ}\text{C}$ to $+85^{\circ}\text{C}$, $V_{DDQ3} = 3.3\text{V} \pm 5\%$ (Lump Capacitance Test Load = 30 pF)

Parameter	Description	Test Condition	Min	Typ	Max	Unit
f_{IN}	Input Frequency	Commercial Temperature Range	0		133	MHz
t_R	Output Rise Edge Rate	Measured from 0.4V to 2.4V	1.5		4.0	V/ns
t_F	Output Fall Edge Rate	Measured from 2.4V to 0.4V	1.5		4.0	V/ns
t_{SR}	Output Skew, Rising Edges				200	ps
t_{SF}	Output Skew, Falling Edges				200	ps
t_{EN}	Output Enable Time		1.0		8.0	ns
t_{DIS}	Output Disable Time		1.0		8.0	ns
t_{PR}	Rising Edge Propagation Delay		3.0	3.85	5.0	ns
t_{PF}	Falling Edge Propagation Delay		3.0	3.85	5.0	ns
t_D	Duty Cycle	Measured at 1.5V	50		60	%
Z_o	AC Output Impedance			15		Ω

Notes:

2. OE, SCLOCK, and SDATA logic pins have a 250-k Ω internal pull-up resistor (not CMOS level).
3. Outputs loaded by 6" 60 Ω transmission lines with 20-pF capacitors.

Test Circuit

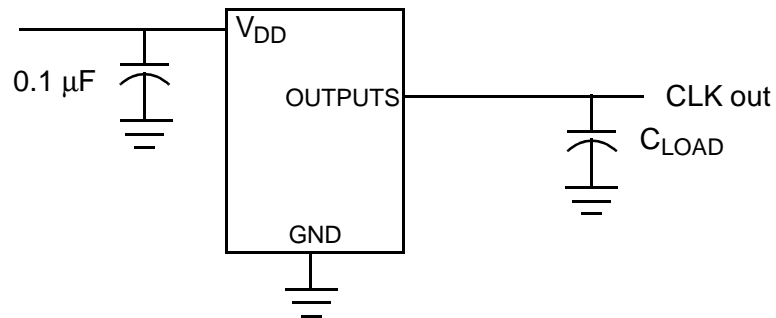

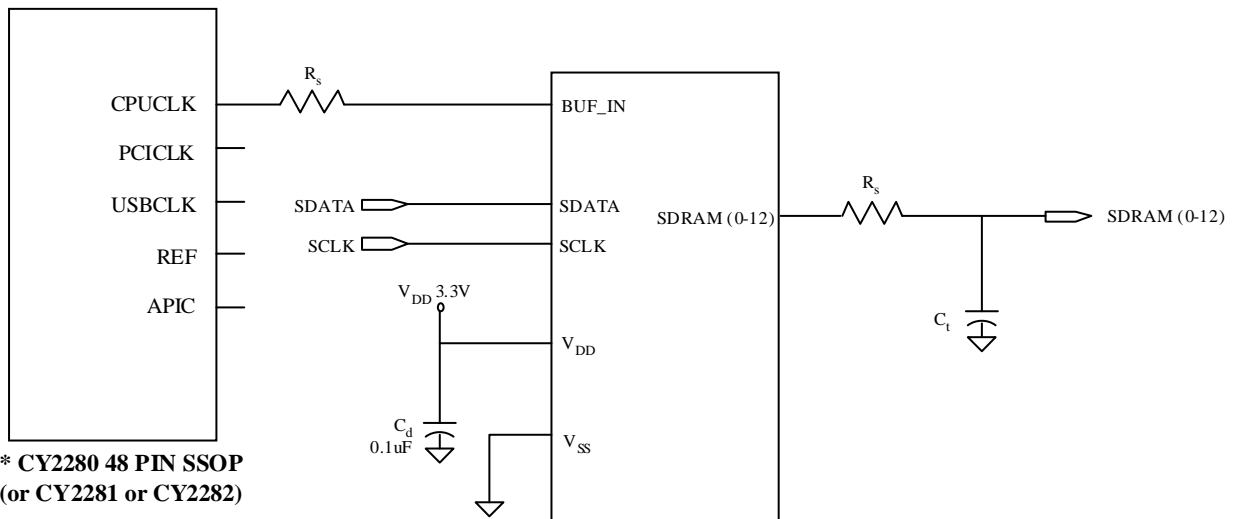
Application Circuit

* CY2280 48 PIN SSOP
(or CY2281 or CY2282)

CY2313A: 28-PIN SOIC

* THIS FREQUENCY SYNTHESIZER IS USED TO GENERATE CPU, PCI, USB, REF, AND APIC CLOCKS.

C_d = DECOUPLING CAPACITORS
 C_t = OPTIONAL EMI-REDUCING CAPACITORS
 R_s = SERIES TERMINATING RESISTORS

Ordering Information

Ordering Code	Package Name	Package Type	Operating Range
CY2318BNZPVI-11	O48	48-Pin SSOP	Industrial (-40°C to 85°C)
CY2318BNZPVC-11	O48	48-Pin SSOP	Commercial (0°C to 70°C)

Package Diagram

48-Lead Shrink Small Outline Package O48

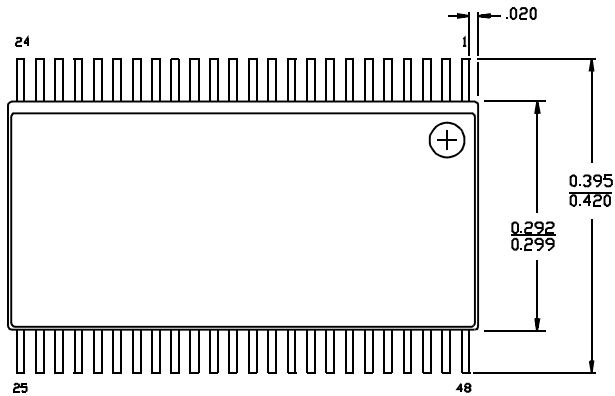

DIMENSIONS IN INCHES MIN.
MAX.

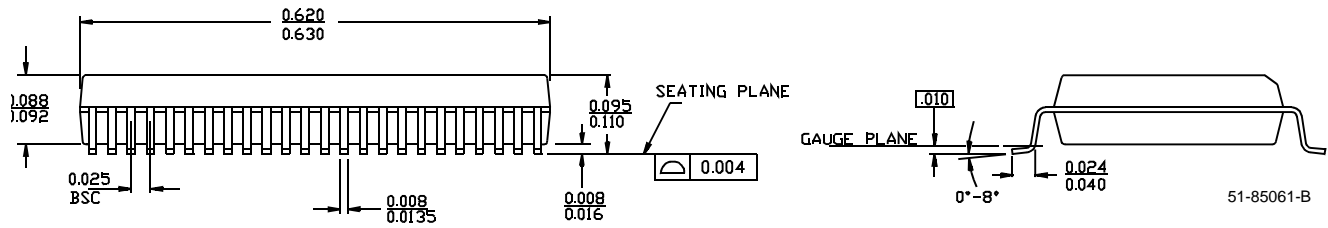

Revision History

Document Title: CY2318BNZ 18 Output, 3.3V SDRAM Buffer for Desktop PCs with 4 DIMMs Document Number: 38-07217				
REV.	ECN NO.	Issue Date	Orig. of Change	Description of Change
**	111855	12/09/01	DSG	Change from Spec number: 38-01091 to 38-07217