

B283000N2

SERIES
 B28= FORM A
 POLES
 2= 2 POLE & 3= 3 POLE
 CURVED BASE DIAMETER
 000= FLAT
 MATERIAL AND HOUSING COLOUR
 N= PA6 BLACK, W= PA6 BLACK V0, G= PA6 GRAY

SCREW AND GASKET
 1= NBR PROFILE GASKET & SCREWS
 2= NBR FLAT GASKET & SCREWS
 4= SILICON FLAT GASKET & SCREWS
 6= NBR FLAT GASKET & NO FIXING SCREWS
 G= SCREWS & NO GASKET

NOTES

- PLEASE SEE TABLE FOR CURRENTLY CONFIGURED PART NUMBERS. FOR SPECIFIC PART NUMBERS PLEASE CONTACT SALES OR CONSULT THE INTELLIGENT PART NUMBERS IN THE TABLE ATTACHED.
- FOR PACKAGING SEE PACKAGING SPEC PK-121012-B28
- PRODUCT SPEC: SEE PS-121201-001
- TERMINALS BENT AFTER INSERTION. SEE TABLE FOR TERMINAL BEND ANGLE

LAST INSPECTION NUMBER 4

PART NO	MPM NO	DESCRIPTION	TERMINAL BEND ANGLE
1210120091	B282000G2	TYPE A 2P GRAY, NBR FLAT GASKET & SCREWS	45
1210120093	B282000N1	TYPE A 2P BLACK, NBR PROFILE GASKET & SCREWS	45
1210120095	B282000N2	TYPE A 2P BLACK, NBR FLAT GASKET & SCREWS	45
1210120096	B282000N4	TYPE A 2P BLACK, SILICON FLAT GASKET & SCREWS	45
1210120097	B282000W2	TYPE A 2P BLACK V0, NBR FLAT GASKET & SCREWS	45
1210120099	B283000N2	TYPE A 3P BLACK, NBR FLAT GASKET & SCREWS	45
1210120100	B283000N4	TYPE A 3P BLACK, SILICON FLAT GASKET & SCREWS	45
1210120101	B283000N6	TYPE A 3P BLACK, NBR FLAT GASKET & NO FIXING SCREWS	45
1210120146	B283000NG	TYPE A 3P BLACK, SCREWS, NO GASKET	45
1210130199	B282000W2SA	TYPE A 2P BLACK, NBR FLAT GASKET & SCREWS, UL LISTED	45
1210130233	B283000W2SA	TYPE A 3P BLACK, NBR FLAT GASKET & SCREWS, UL LISTED	45

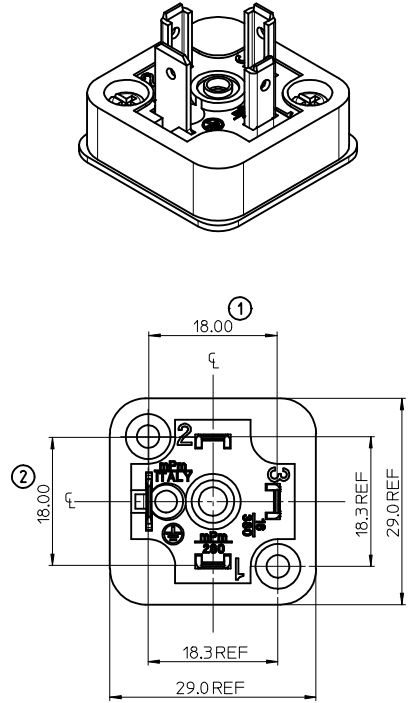
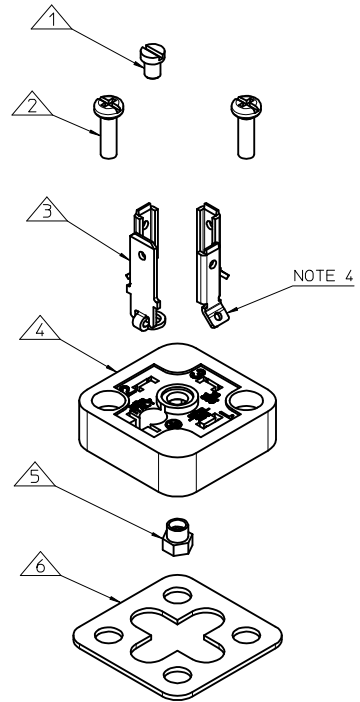

ITEM	DESCRIPTION
1	EARTH SCREW
2	FIXING SCREWS
3	TERMINALS
4	HOUSING
5	INSERT
6	GASKET

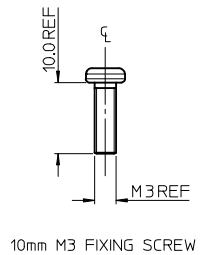
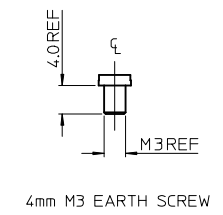
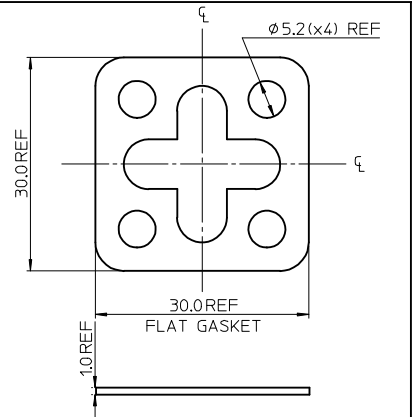
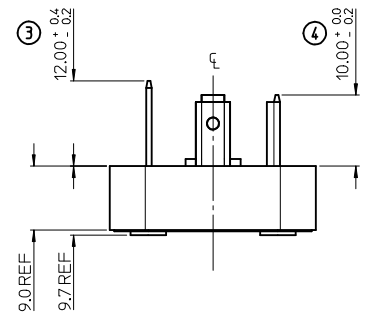

TOLERANCE UPDATE EC NO: IFC2014-0532 DRW:KORNOYLE 2013/09/30 CHKD:DSHEA 2013-10-23 APPR:STGERFFIN 2013/11/11	QUALITY SYMBOLS ▽=0 ▽=0	GENERAL TOLERANCES (UNLESS SPECIFIED)		DIMENSION STYLE MM ONLY		SCALE 2:1	DESIGN UNITS METRIC	THIRD ANGLE PROJECTION	
		4 PLACES ± --- ± --- 3 PLACES ± --- ± --- 2 PLACES ± 0.10 ± --- 1 PLACE ± 0.2 ± --- ANGULAR ± ---°	mm INCH	DRAWN BY DSHEA 2011/06/10	DATE 2011/06/10	TITLE B28 SERIES BASES			
DRAFT WHERE APPLICABLE MUST REMAIN WITHIN DIMENSIONS		APPROVED BY EFOLAN 2011/06/30		MATERIAL NO. SEE TABLE		DOCUMENT NO. SD-121012-003		SHEET NO. 1 OF 1	
THIS DRAWING CONTAINS INFORMATION THAT IS PROPRIETARY TO MOLEX INCORPORATED AND SHOULD NOT BE USED WITHOUT WRITTEN PERMISSION									