

ISL6446

Dual (180° Out-of-Phase) PWM and Linear Controller

FN7944  
Rev 2.00  
October 12, 2015

The **ISL6446** is a high-performance, triple output controller that provides a single high-frequency power solution primarily for broadband, DSL and networking applications. This device integrates complete control, monitoring and protection functions for two synchronous buck PWM controllers and one linear controller. Input voltage ripple and total RMS input current is substantially reduced by synchronized 180° out-of-phase operation of the two PWMs.

The two PWM buck converters provide simple voltage mode control. The output voltage of the converters can be precisely regulated to as low as 0.6V, with a maximum tolerance of ±1.5% over-temperature and line variations. Programmable switching frequency down to 100kHz provides optimized low cost solution for ATX power supplies. It's also able to operate up to 2.5MHz to deliver compact solutions. The linear controller provides a low-current output.

Each PWM controller has soft-start and independent enable functions combined on a single pin. A capacitor from SS/EN to ground sets the soft-start time; pulling SS/EN pin below 1V disables the controller. Both outputs can soft-start into a prebiased load.

The ISL6446 incorporates robust protection features. An adjustable overcurrent protection circuit monitors the output current by sensing the voltage drop across the upper MOSFET  $r_{DS(ON)}$ . Latch-off mode overcurrent operation protects the DC/DC converters from damage under overload and short-circuit conditions. A PGOOD signal is issued when soft-start is complete and PWM outputs are within 10% of their regulated values and the linear regulator output is higher than 75% of its nominal value. Thermal shutdown circuitry turns the device off if the IC temperature exceeds +150° C.

**Features**

- 4.5V to 5.5V or 5.5V to 24V input voltage range
- Three programmable power output voltages
  - Two PWM controllers with out-of-phase operation
  - Voltage-mode PWM control
  - One linear controller
- Programmable switching frequency from 100kHz to 2.5MHz
- Fast transient response
  - High-bandwidth error amplifier
- Extensive circuit protection functions
  - Undervoltage and over-temperature
  - Overvoltage with latch-off mode
  - Programmable overcurrent limit with latch-off mode
  - Lossless current sensing (no sense resistor needed)
- Externally adjustable soft-start time
  - Independent enable control
  - Voltage tracking capability
  - Able to soft-start into a prebiased load
- PGOOD output with delay

**Applications**

- ATX power supplies
- DSP, ASIC and FPGA point of load regulation
- Industrial and security networking applications

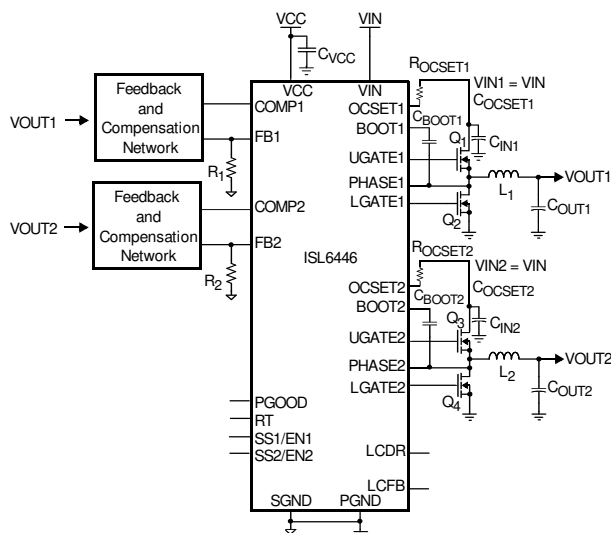

FIGURE 1. TYPICAL APPLICATION

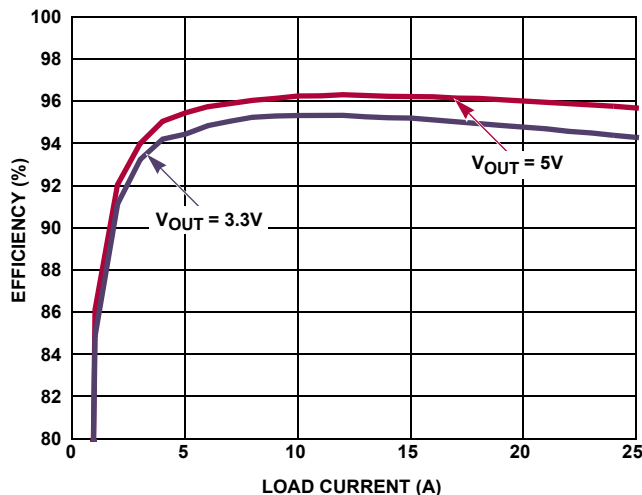
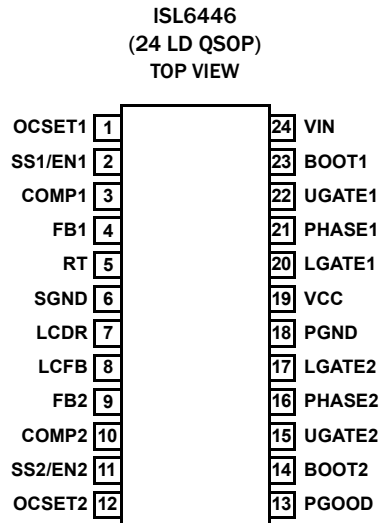

FIGURE 2. EFFICIENCY vs LOAD CURRENT (OBTAINED FROM ISL6446EVAL1Z)

## Pin Configuration



## Pin Descriptions

SYMBOL	PIN #	DESCRIPTION						
BOOT2, 1	14, 23	These pins power are the upper MOSFET drivers of each PWM converter. The anode of each internal bootstrap diode is connected to the VCC pin. The cathode of the bootstrap diode is connected to this pin, which should also connect to the bootstrap capacitor.						
UGATE2, 1	15, 22	These pins provide the gate drive for upper MOSFETs, bootstrapped from the VCC pin.						
PHASE2, 1	16, 21	These are the junction points of the upper MOSFET sources, the output filter inductor and lower MOSFET drains. Connect these pins accordingly to the respective converter.						
LGATE2, 1	17, 20	These are the outputs of the lower N-Channel MOSFET drivers, sourced from the VCC pin.						
PGND	18	This pin provides the power ground connection for the lower gate drivers. This pin should be connected to the source of the lower MOSFET for PWM1 and PWM2 and the negative terminals of the external input capacitors.						
FB1, 2	4, 9	These pins are connected to the feedback resistor divider and provide the voltage feedback signals for the respective controller. They set the output voltage of the converter. In addition, the PGOOD circuit and OVP circuit use these inputs to monitor the output voltage status.						
COMP1, 2	3, 10	These pins are the error amplifier outputs for the respective PWM. They are used, along with the FB pins, as the compensation point for the PWM error amplifier.						
PGOOD	13	This is an open drain logic output used to indicate the status of the output voltages. This pin is pulled low when either of the two PWM outputs is not within 10% of the respective nominal voltage or when the linear output drops below 75% of its nominal voltage. To maintain the PGOOD function if the linear output is not used, connect LCFB to VCC.						
SGND	6	This is the signal ground, common to both controllers, and must be routed separately from the high current grounds (PGND). All voltage levels are measured with respect to this pin.						
VIN	24	<p>This pin powers the controllers with an internal linear regulator (if VIN &gt; 5.5V) and must be closely decoupled to ground using a ceramic capacitor as close to the VIN pin as possible. The VIN is the input voltage applied to the upper FET of both converters.</p> <p style="text-align: center;"><b>TABLE 1. INPUT SUPPLY CONFIGURATION</b></p> <table border="1" style="margin-left: auto; margin-right: auto;"> <thead> <tr> <th>INPUT</th> <th>PIN CONFIGURATION</th> </tr> </thead> <tbody> <tr> <td>5.5V to 24V</td> <td>Connect the input supply to the VIN pin. The VCC pin will provide a 5V output from the internal voltage regulator.</td> </tr> <tr> <td>5V ±10%</td> <td>Connect the input supply to the VCC pin.</td> </tr> </tbody> </table>	INPUT	PIN CONFIGURATION	5.5V to 24V	Connect the input supply to the VIN pin. The VCC pin will provide a 5V output from the internal voltage regulator.	5V ±10%	Connect the input supply to the VCC pin.
INPUT	PIN CONFIGURATION							
5.5V to 24V	Connect the input supply to the VIN pin. The VCC pin will provide a 5V output from the internal voltage regulator.							
5V ±10%	Connect the input supply to the VCC pin.							
VCC	19	This pin supplies the bias for the regulators, powers the low-side gate drivers and external boot circuitry for high-side gate drivers. The IC may be powered directly from a single 5V (±10%) supply at this pin; when used as a 5V supply input, this pin must be externally connected to VIN. When VIN > 5.5, VCC is the output of the internal 5V linear regulator output. The VCC pin must always be decoupled to power ground with a minimum of 1µF ceramic capacitor, placed very close to the pin.						

## Pin Descriptions (Continued)

SYMBOL	PIN #	DESCRIPTION
RT	5	This is the operating frequency adjustment pin. By placing a resistor from this pin to the SGND, the oscillator frequency can be programmed from 100kHz to 2.5MHz.
SS1/EN1 SS2/EN2	2, 11	These pins provide enable/disable and soft-start function for their respective controllers. The output is held off when the pin is pulled to ground. When the chip is enabled, the regulated 30µA pull-up current source charges the capacitor connected from the pin to ground. The output voltage of the converter follows the ramping voltage on the SS/EN pin. See <a href="#">“Soft-Start and Voltage Tracking” on page 11</a> for more details.
LCFB	8	This pin is the feedback pin for the linear controller. An external voltage divider network connected to this pin sets the output voltage of the linear controller. If the linear controller is not used, tie this pin to VCC.
LCDR	7	Open drain output PNP Transistor or P-channel MOSFET Driver. The LCDR connects to the base of an external PNP pass transistor or the gate of the MOSFET to form a positive linear regulator. A small resistor can be inserted between the LCDR and the base of the PNP pass transistor or the gate of the MOSFET to alleviate thermal stress at output short condition.
OCSET1, 2	1, 12	<p>These pins are the overcurrent set points for the respective PWM controllers. Connect a resistor (<math>R_{OCSET}</math>) from this pin to the drain of the upper MOSFET. <math>R_{OCSET}</math>, an internal 110µA current source, and the upper MOSFET ON-resistance <math>r_{DS(ON)}</math> set the converter overcurrent (OC) trip point according to <a href="#">Equation 1</a>:</p> $I_{OC} = \frac{I_{OCSET} \cdot R_{OCSET}}{r_{DS(ON)}} \quad (\text{EQ. 1})$ <p><math>I_{OC}</math> includes the DC load current, as well as the ripple current. An overcurrent trip initiates hiccup mode. The voltage on the OCSET pin should not exceed 0.7V above the VIN pin voltage for proper current sensing when the UGATE is turned on.</p>

## Ordering Information

PART NUMBER (Notes 1, 2, 3)	PART MARKING	TEMP RANGE (°C)	PACKAGE (RoHS Compliant)	PKG. DWG. #
ISL6446IAZ	ISL 6446IAZ	-40 to +85	24 Ld QSOP	M24.15

### NOTES:

1. Add “-T\*” suffix for tape and reel. Please refer to [TB347](#) for details on reel specifications.
2. These Intersil Pb-free plastic packaged products employ special Pb-free material sets, molding compounds/die attach materials, and 100% matte tin plate plus anneal (e3 termination finish, which is RoHS compliant and compatible with both SnPb and Pb-free soldering operations). Intersil Pb-free products are MSL classified at Pb-free peak reflow temperatures that meet or exceed the Pb-free requirements of IPC/JEDEC J STD-020.
3. For Moisture Sensitivity Level (MSL), please see device information page for [ISL6446](#). For more information on MSL please see tech brief [TB363](#).

# Block Diagram

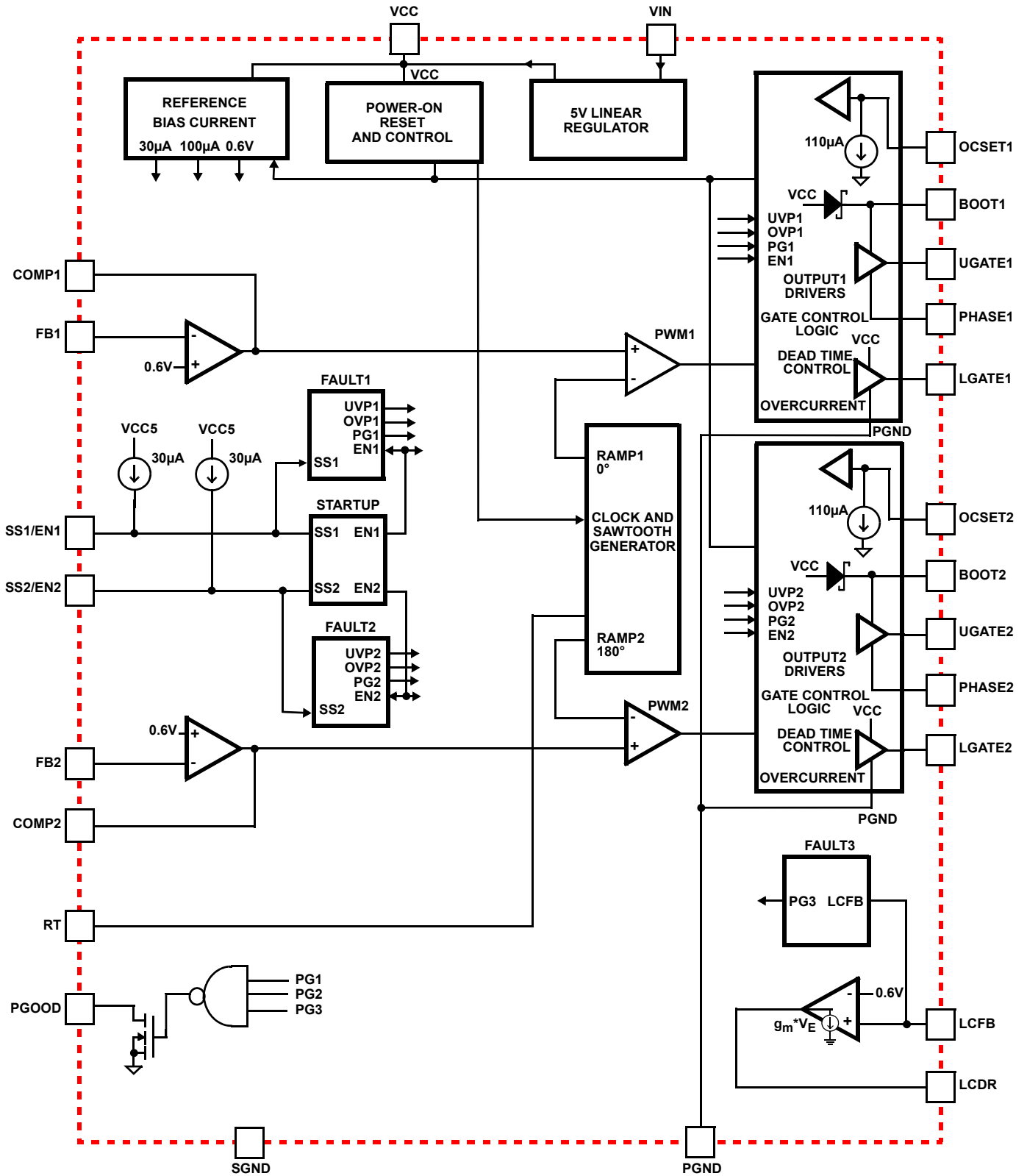
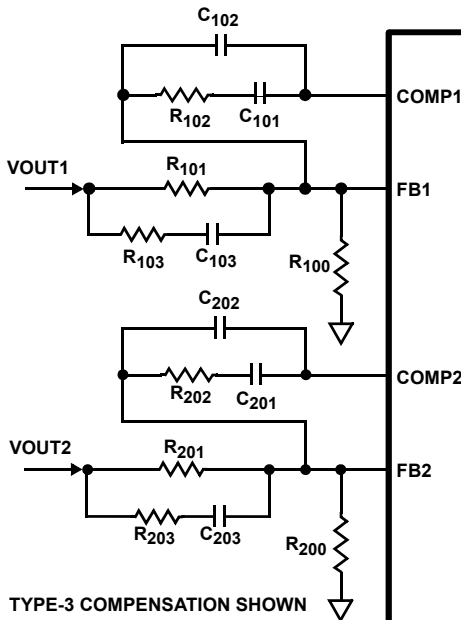

FIGURE 3. BLOCK DIAGRAM

# Typical Application Schematic

VOLTAGE INPUTS REQUIRED  
 VIN (4.5V TO 24V) = VIN1 = VIN2  
 VCC (5V; INTERNAL IF VIN > 5.6V)  
 VIN3 ( $\leq$ VCC) FOR LINEAR

TYPE-3 COMPENSATION SHOWN



TYPE-3 COMPENSATION SHOWN

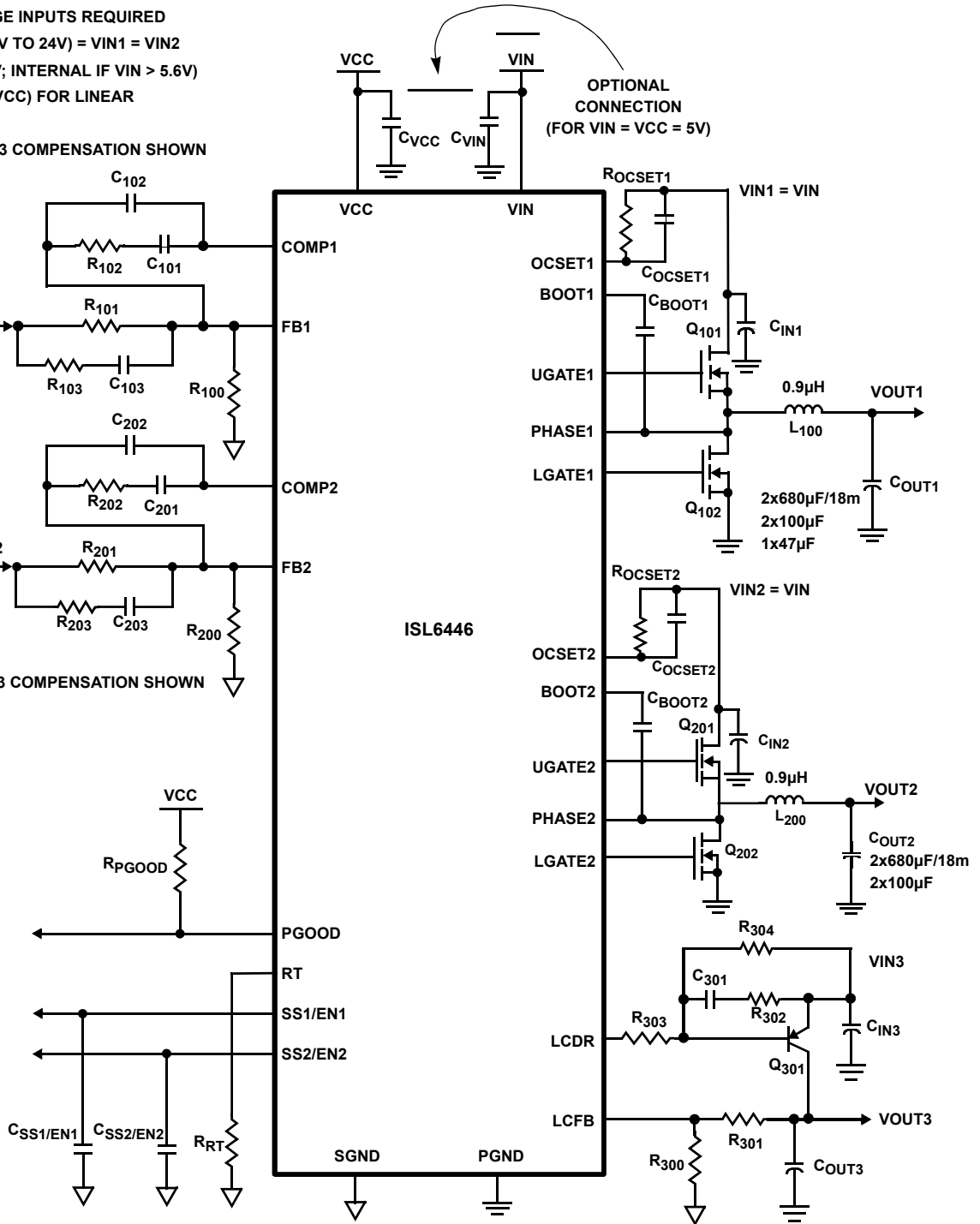

FIGURE 4. ISL6446 TYPICAL APPLICATION

**Absolute Maximum Ratings** (Note 4)

SS1/EN1, SS2/EN2, COMP1, COMP2 to SGND	-0.3V to +6.0V
VCC, FB1, FB2, RT, PGOOD to SGND	-0.3V to +6.0V
LCDR, LCFB to SGND	-0.3V to +6.0V
VIN, OCSET1 and OCSET2 to PGND	-0.3V to +28V
BOOT1 and BOOT2 to PGND	-0.3V to +33V
BOOT1 to PHASE1 and BOOT2 to PHASE2	-0.3V to +6.0V
UGATE1 to PHASE1	-0.3V to (BOOT1 + 0.3V)
UGATE2 to PHASE2	-0.3V to (BOOT2 + 0.3V)
LGATE1, LGATE2 to PGND	-0.3V to (VCC + 0.3V)
PHASE1, PHASE2 to PGND	-1V to 28V
SGND to PGND	-0.3V to 0.3V

## ESD Rating

Human Body Model (Tested per JESD22-A114E)	2.5kV
Machine Model (Tested per JESD22-115-A)	150V
Latch-up (Tested per JEDEC-78B Level II Class A)	±100mA at +85°C

**Thermal Information**

Thermal Resistance (Typical)	$\theta_{JA}$ (°C/W)	$\theta_{JC}$ (°C/W)
QSOP Package (Notes 5, 6)	75	36
Maximum Junction Temperature (Plastic Package)	-55°C to +150°C	
Maximum Storage Temperature Range	-65°C to +150°C	
Temperature Range	-40°C to +85°C	
Pb-free Reflow Profile	see <a href="#">TB493</a>	

**Recommended Operating Conditions**

V <sub>CC</sub> Supply Voltage	5V ±10%
V <sub>IN</sub> Supply Voltage	5.5V to 24V

CAUTION: Do not operate at or near the maximum ratings listed for extended periods of time. Exposure to such conditions may adversely impact product reliability and result in failures not covered by warranty.

## NOTES:

- All voltages are measured with respect to GND.
- $\theta_{JA}$  is measured with the component mounted on a high effective thermal conductivity test board in free air. See Tech Brief [TB379](#) for details.
- For  $\theta_{JC}$ , the "case temp" location is taken at the package top center.

**Electrical Specifications** Operating conditions unless otherwise noted: V<sub>IN</sub> = 12V, or V<sub>CC</sub> = 5V ±10%, T<sub>A</sub> = -40°C to +85°C. Typical values are at +25°C. **Boldface limits apply across the operating temperature range, -40°C to +85°C**

PARAMETER	SYMBOL	TEST CONDITIONS	MIN (Note 9)	TYP	MAX (Note 9)	UNIT
<b>VIN SUPPLY</b>						
Input Operating Supply Current	I <sub>CC_op</sub>	V <sub>IN</sub> = 5.5V or 12V; LGATE <sub>x</sub> , UGATE <sub>x</sub> Open, FB forced above regulation point (no switching)		4.5	<b>7.5</b>	mA
Input Standby Supply Current	I <sub>CC_sb</sub>	V <sub>IN</sub> = 5.5V, 12V, 24V; SS1/EN1 = SS2/EN2 = 0V		1.25	<b>3</b>	mA
<b>VCC INTERNAL REGULATOR</b>						
Output Voltage	V <sub>VCC</sub>	V <sub>IN</sub> = 5.6V, SS1/EN1 = SS2/EN2 = 0V No additional load	<b>4.5</b>	5.35		V
Output Voltage	V <sub>VCC</sub>	V <sub>IN</sub> = 24V, SS1/EN1 = SS2/EN2 = 0V No additional load		5.36	<b>5.6</b>	V
Output Voltage	V <sub>VCC</sub>	V <sub>IN</sub> = 12V, SS1/EN1 = SS2/EN2 = 0V IVCC = 80mA	<b>4.5</b>	5.2		V
VCC Current Limit (Note 7)	I <sub>CC_CL</sub>	VCC is pulled to PGND (Note 8)		300		mA
<b>REFERENCE AND SOFT-START</b>						
Reference Voltage at FB1, FB2	V <sub>REF1</sub> , V <sub>REF2</sub>	V <sub>IN</sub> = 5V or 12V; T <sub>A</sub> = +25°C		0.6000		V
		V <sub>IN</sub> = 5V or 12V; T <sub>A</sub> = 0°C to +85°C	0.5925		0.6085	V
		V <sub>IN</sub> = 5V or 12V; T <sub>A</sub> = -40°C to +85°C	<b>0.5900</b>		<b>0.6085</b>	V
Reference Voltage at FB1, FB2	V <sub>REF1</sub> , V <sub>REF2</sub>	V <sub>IN</sub> = 24V; T <sub>A</sub> = +25°C		0.6015		V
		V <sub>IN</sub> = 24V; T <sub>A</sub> = 0°C to +85°C	0.5930		0.6100	V
		V <sub>IN</sub> = 24V; T <sub>A</sub> = -40°C to +85°C	<b>0.5915</b>		<b>0.6100</b>	V
EN <sub>x</sub> /SS <sub>x</sub> Soft-start Current	I <sub>SSx</sub>		<b>20</b>	30	<b>40</b>	μA
EN <sub>x</sub> /SS <sub>x</sub> Enable Threshold	V <sub>ENx</sub>		<b>850</b>	940	<b>1050</b>	mV
EN <sub>x</sub> /SS <sub>x</sub> Enable Threshold Hysteresis	V <sub>ENx_hys</sub>	(Note 7)		15		mV
EN <sub>x</sub> /SS <sub>x</sub> Soft-Start Top of Ramp Voltage	V <sub>SSx_top</sub>	(Note 7)		3.12		V

**Electrical Specifications** Operating conditions unless otherwise noted:  $V_{IN} = 12V$ , or  $V_{CC} = 5V \pm 10\%$ ,  $T_A = -40^\circ C$  to  $+85^\circ C$ . Typical values are at  $+25^\circ C$ . **Boldface limits apply across the operating temperature range,  $-40^\circ C$  to  $+85^\circ C$  (Continued)**

PARAMETER	SYMBOL	TEST CONDITIONS	MIN (Note 9)	TYP	MAX (Note 9)	UNIT
<b>POWER-ON RESET ON VCC</b>						
Rising Threshold	$V_{POR\_r}$		<b>4.2</b>	4.4	<b>4.48</b>	V
Falling Threshold	$V_{POR\_f}$		<b>3.85</b>	4.0	<b>4.1</b>	V
<b>PWM CONVERTERS</b>						
Minimum UGATE On-time	$t_{UGATE\_min}$	(Note 7)		<b>100</b>		ns
Maximum Duty Cycle	$DC_{max}$	$V_{IN} = 5V$ or $12V$ ; $f_{SW} = 300kHz$	<b>95</b>			%
Maximum Duty Cycle	$DC_{max}$	$V_{IN} = 5V$ ; $f_{SW} = 2.58MHz$	<b>80</b>			%
$FB_x$ Pin Bias Current	$I_{FBx}$	$V_{FB1} = V_{FB2} = 600mV$	<b>-250</b>	30	<b>250</b>	nA
<b>OSCILLATOR</b>						
Low-end Frequency	$f_{SW}$	$V_{IN} = 12V$ ; $R_T = 163k\Omega$		103		kHz
Oscillation Frequency	$f_{SW}$	$V_{IN} = 5V$ or $12V$ ; $R_T = 52.3k\Omega$	<b>270</b>	300	<b>330</b>	kHz
		$V_{IN} = 24V$ ; $R_T = 52.3k\Omega$	<b>270</b>	305	<b>340</b>	kHz
High-end Frequency	$f_{SW}$	$V_{IN} = 5V$ ; $R_T = 4.75k\Omega$	<b>2.25</b>	2.5	<b>2.75</b>	MHz
		$V_{IN} = 12V$ ; $R_T = 4.75k\Omega$	<b>2.25</b>	2.59	<b>2.85</b>	MHz
Frequency Adjustment Range	$f_{SW}$	$R_T = 163k\Omega$ ; (Note 7)		0.1		MHz
		$R_T = 4.75k\Omega$ ; (Note 7)		2.6		MHz
PWM Sawtooth Ramp Amplitude (Peak-to-peak)	$V_{P-P}$	(Note 8)		1.25		V
PWM Sawtooth Ramp Offset	$V_{PWM\_OFF}$	(Note 8)		1.25		V
<b>PWM CONTROLLER GATE DRIVERS (Note 7)</b>						
Upper Gate Pull-up Resistance				2.6		$\Omega$
Upper Gate Pull-down Resistance				2		$\Omega$
Lower Gate Pull-up Resistance				2.6		$\Omega$
Upper Gate Pull-down Resistance				2		$\Omega$
Rise Time		$C_L = 3300pF$		25		ns
Fall Time		$C_L = 3300pF$		25		ns
Dead Time Between Drivers				20		ns
<b>ERROR AMPLIFIERS</b>						
DC Gain	Gain	(Note 8)		88		dB
Gain-bandwidth Product	GBWP	(Note 8)		15		MHz
Slew Rate	SR	COMP = 10pF (Note 8)		5		V/ $\mu s$
Maximum Output Voltage	$V_{EA\_H}$	$I_{COMP\_SRC} = 40\mu A$	<b>3.9</b>	4.2		V
Minimum Output Voltage	$V_{EA\_L}$	$I_{COMP\_SINK} = 40\mu A$		0.8	<b>1.1</b>	V
<b>PROTECTION AND OUTPUT MONITOR</b>						
Overvoltage Threshold	OV		<b>111</b>	116	<b>121</b>	%
Undervoltage Threshold	UV		<b>77</b>	82	<b>88</b>	%
OCSET Current Source	$I_{OCSET}$	$V_{OCSET} = 4.5V$ , $T_A = -40^\circ C$	<b>80</b>			$\mu A$
OCSET Current Source	$I_{OCSET}$	$V_{OCSET} = 4.5V$ , $T_A = +25^\circ C$		110		$\mu A$
OCSET Current Source	$I_{OCSET}$	$V_{OCSET} = 4.5V$ , $T_A = +85^\circ C$			<b>140</b>	$\mu A$
<b>LINEAR CONTROLLER</b>						
Drive Sink Current	$I_{LCDR}$	LCDR	<b>50</b>			mA
LCFB Feedback Threshold	$V_{LCFB}$	$T_A = +25^\circ C$		0.595		V
		$T_A = -40^\circ C$ to $+85^\circ C$	<b>0.570</b>		<b>0.620</b>	V
		$T_A = 0^\circ C$ to $+70^\circ C$	0.580		0.610	V

**Electrical Specifications** Operating conditions unless otherwise noted:  $V_{IN} = 12V$ , or  $V_{CC} = 5V \pm 10\%$ ,  $T_A = -40^\circ C$  to  $+85^\circ C$ . Typical values are at  $+25^\circ C$ . **Boldface limits apply across the operating temperature range,  $-40^\circ C$  to  $+85^\circ C$  (Continued)**

PARAMETER	SYMBOL	TEST CONDITIONS	MIN (Note 9)	TYP	MAX (Note 9)	UNIT
LCFB Input Leakage Current	$I_{LCFB}$	(Note 7)		80		nA
Error Amplifier Transconductance	gm	$V_{LCFB} = 0.6V$ , $I_{LCDR} = 21mA$ (Note 7)		2		A/V
<b>PGOOD</b>						
Power-good Lower Threshold	PG_low <sub>x</sub>	LCFB = VCC, L <sub>DO</sub> disabled PGOOD for Ch1 and Ch2 only	<b>88</b>	93	<b>97</b>	%
Power-good Higher Threshold	PG_hi <sub>x</sub>	LCFB = VCC, L <sub>DO</sub> disabled PGOOD for Ch1 and Ch2 only	<b>105</b>	110	<b>115</b>	%
Power-good Lower Threshold	PG_low <sub>3</sub>	L <sub>DO</sub> enabled, PGOOD for L <sub>DO</sub> ; Ch1 and Ch2 disabled; (Note 7)		72		%
PGOOD Delay	t <sub>PGOOD</sub>	f <sub>SW</sub> = 1.4MHz (Note 7)		46		ms
PGOOD Leakage Current	I <sub>PGOOD</sub>	V <sub>PULLUP</sub> = 5.5V			<b>5</b>	μA
PGOOD Voltage Low	V <sub>PG_low</sub>	I <sub>PGOOD</sub> = -4mA			<b>0.5</b>	V
<b>THERMAL</b>						
Shutdown Temperature		(Note 8)		150		°C
Shutdown Hysteresis		(Note 8)		20		°C

**NOTES:**

7. Limits established by characterization.
8. Design guideline only; not production tested.
9. Parameters with MIN and/or MAX limits are 100% tested at  $+25^\circ C$ , unless otherwise specified. Temperature limits established by characterization and are not production tested.





# Typical Performance Curves

Oscilloscope plots are taken using the ISL6446EVAL1Z evaluation board,  $V_{IN} = 12V$ ,  $V_{OUT1} = 5V$ ,  $V_{OUT2} = 3.3V$ ,  $f_{SW} = 300kHz$ , unless otherwise noted. (Continued)

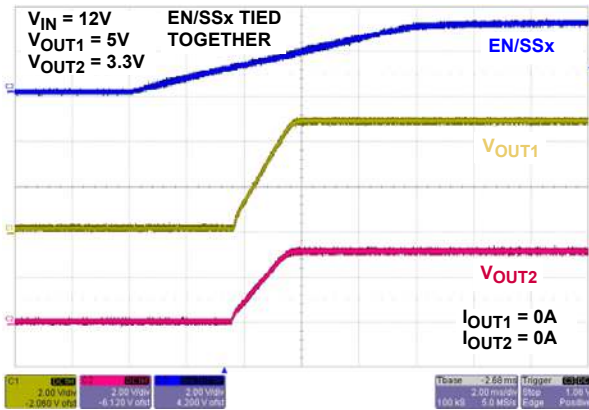

FIGURE 10. EN/SS START-UP

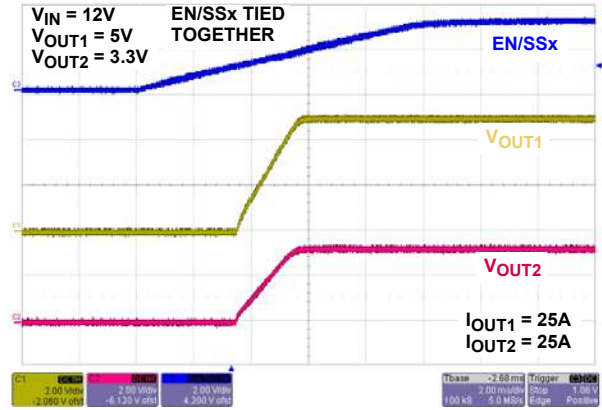

FIGURE 11. EN/SS START-UP

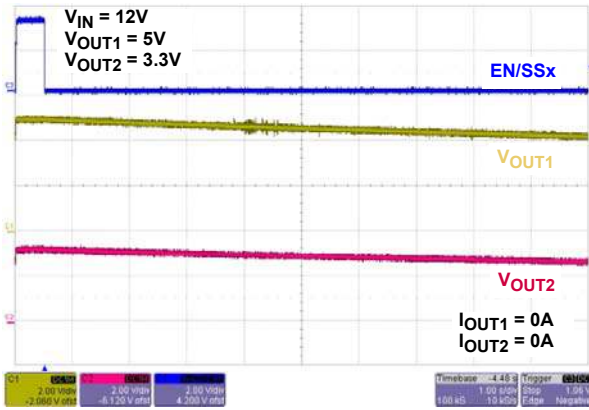

FIGURE 12. EN/SS SHUTDOWN

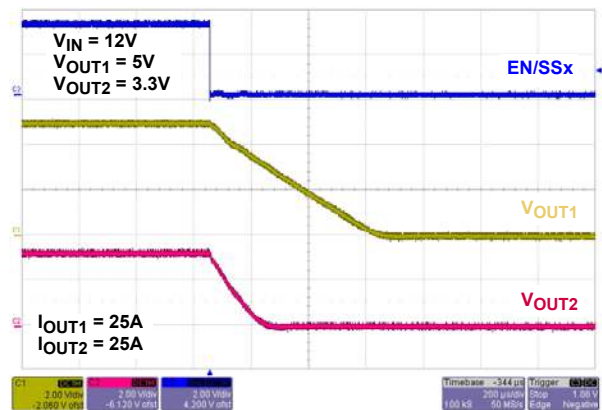

FIGURE 13. EN/SS SHUTDOWN

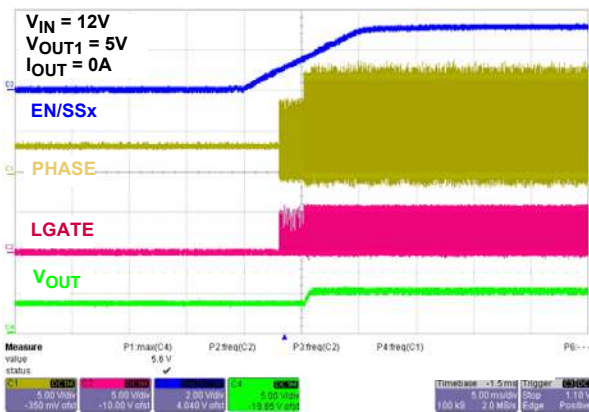

FIGURE 14. PREBIASED START-UP ( $V_{OUT}$  PRE-BIASED AT 3.5V)

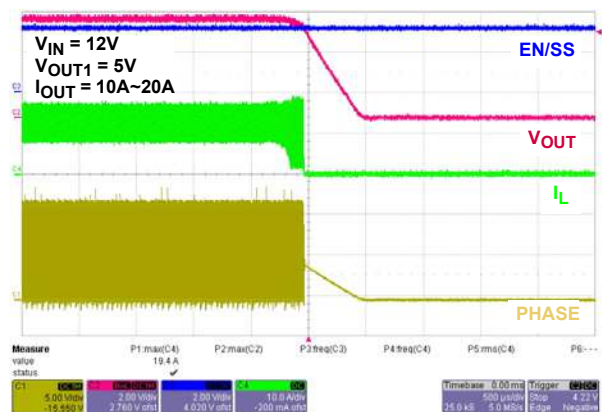

FIGURE 15. OVERCURRENT PROTECTION

**Typical Performance Curves** Oscilloscope plots are taken using the ISL6446EVAL1Z evaluation board,  $V_{IN} = 12V$ ,  $V_{OUT1} = 5V$ ,  $V_{OUT2} = 3.3V$ ,  $f_{SW} = 300kHz$ , unless otherwise noted. (Continued)

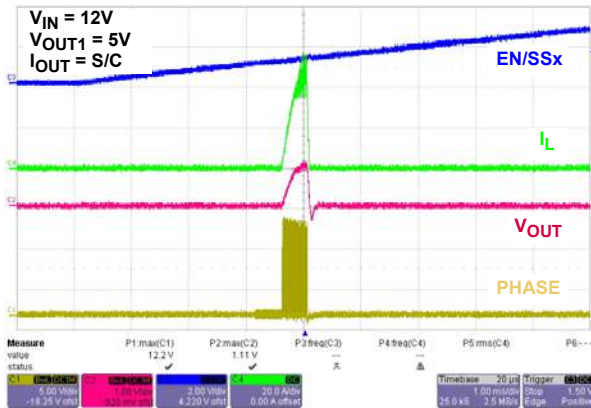

FIGURE 16. START-UP WITH OC

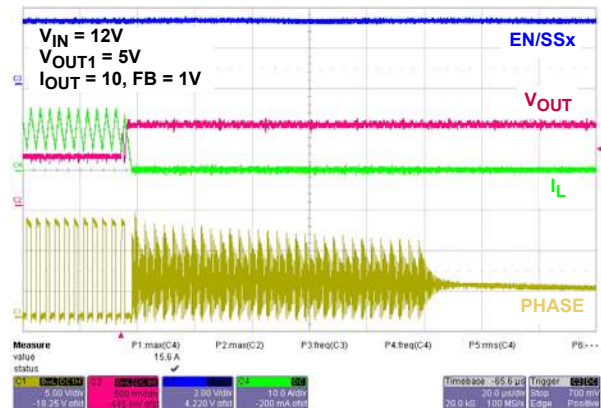

FIGURE 17. OVERVOLTAGE PROTECTION

**Functional Description**

**Soft-Start and Voltage Tracking**

After the VCC pin exceeds its rising POR trip point (nominal 4.4V), the chip operation begins. Both 30µA current sources will start charging up the soft-starting capacitors respectively. The charging continues until the voltage across the soft-start capacitor reaches about 3.2V. From 1.0V to 1.6V, the outputs will ramp individually from zero to full-scale. Now, if  $V = 0.6V$ ,  $C = 0.1\mu F$ , and  $I = 30\mu A$ , then  $t = 2ms$ . Figure 18 shows the typical waveforms for SS2/EN2 and  $V_{OUT2}$ ; SS1/EN1 and  $V_{OUT1}$  are similar (see Figure 19).

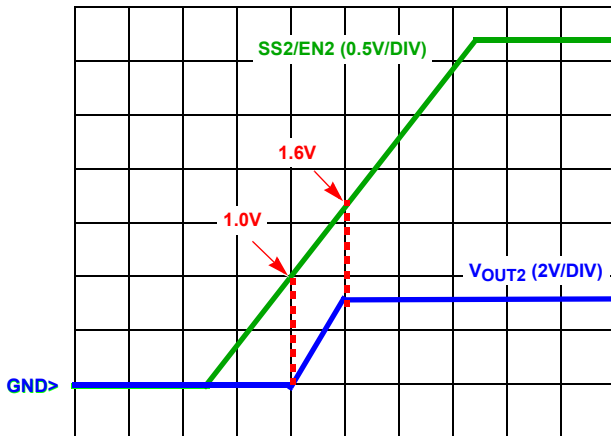

FIGURE 18. SOFT-START

The soft-start ramps for each output can be selected independently. The basic timing is shown in Equation 2:

$$t = C \cdot \frac{dV}{I} \tag{EQ. 2}$$

Where:

- t is the charge time
- C is the external capacitance
- dV is the voltage charged
- I is the charging current (nominal 30µA)

Finally, there is a delay after 1.6V, until the ramp gets to ~3.2V, which signals that the ramp is done; when both ramps are done, the PGOOD delay begins. To guarantee the soft-start is completed, please make sure the EN/SSx pin voltage is able to reach above 3.2V at normal operation.

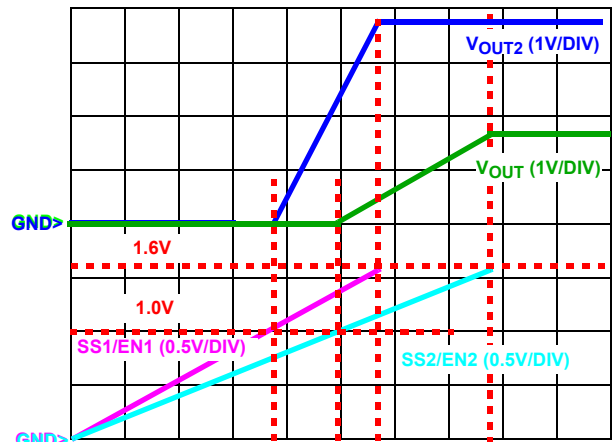

FIGURE 19. VOLTAGE TRACKING

Figure 20 shows prebiased outputs before soft-start. The solid blue curve shows no prebias; the output starts ramping from GND. The magenta dotted line shows the output prebiased to a voltage less than the final output. The FETs don't turn on until the soft-start ramp voltage exceeds the output voltage; then the output starts ramping seamlessly from there. The cyan dotted line shows the output prebiased above the final output (but below the OVP (Overvoltage Protection)). The FETs will not turn on until the end of the soft-start ramp; then the output will be quickly pulled down to the final value.

If the output is prebiased above the OVP level, the ISL6446 will go into OVP at the end of soft-start, which will keep the FETs off. See "Protection Mechanisms" on page 13 for more details.

$V_{OUT1}$  has the same functionality as previously described for  $V_{OUT2}$ . Each output should react independently of the other, unless they are related by the circuit configuration.

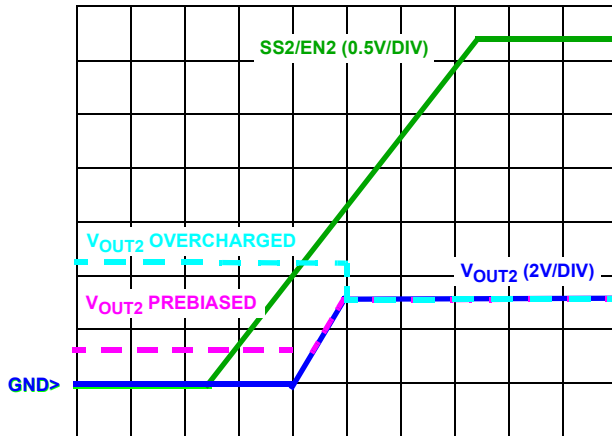

FIGURE 20. SOFT-START WITH PREBIAS

The linear output does not have a soft-start ramp; however, it may follow the ramp of its input supply, if timed to coincide with its rise, after the VCC rising POR trip. If the input to the linear is from one of the two switcher outputs, then it will share the same ramp rate as the switcher.

## PGOOD

A group of comparators (separate from the protection comparators) monitor the output voltages (via the FB pins) for PGOOD. Each switcher has a lower and upper boundary (nominally around 90% and 110% of the target value) and the linear has a lower boundary (around 75% of the target). Once both switcher output ramps are done, and all 3 outputs are within their expected ranges, the PGOOD will start an internal timer, with Equation 3:

$$t_{PGOOD} = \frac{0.065}{f_{SW}} \quad (\text{EQ. 3})$$

Where:

$t_{PGOOD}$  is the delay time (in sec)

$f_{SW}$  is the switching frequency (in MHz)

Once the time-out is complete, the internal pull-down device will shut off, allowing the open-drain PGOOD output to rise through an external pull-up resistor, to a 5V (or lower) supply, which signals that the “Power is GOOD”. Figure 21 shows the three outputs turning on, and the delay for PGOOD. If any of the conditions is subsequently violated, then PGOOD goes low. Once the voltage returns to the normal region, a new delay will start after which the PGOOD will go high again.

The PGOOD delay is inversely proportional to the clock frequency. If the clock is running as slow as 524kHz, the delay will be 125ms long. There is no way to adjust the PGOOD delay independently of the clock.

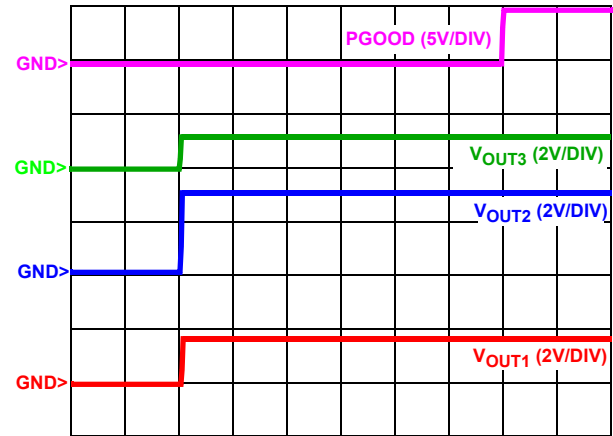

FIGURE 21. PGOOD DELAY

## Switching Frequency

The switching frequency of the ISL6446 is determined by the external resistor placed from the  $R_T$  pin to SGND. See Figure 22 for a graph of Frequency vs  $R_T$  Resistance. Use Equation 4 to calculate the approximate  $R_T$  resistor value for the desired switching frequency. The typical resistance for 100kHz operation is 163k $\Omega$ . Running at both high frequency and high  $V_{IN}$  voltages is not recommended, due to the increased power dissipation on-chip (mostly from the internal VCC regulator, which supplies gate drivers). The user should check the maximum acceptable IC temperature, based on their particular conditions.

$$R_T = \left( \frac{f_{SW}}{11290} \right)^{-1.093} \quad (\text{EQ. 4})$$

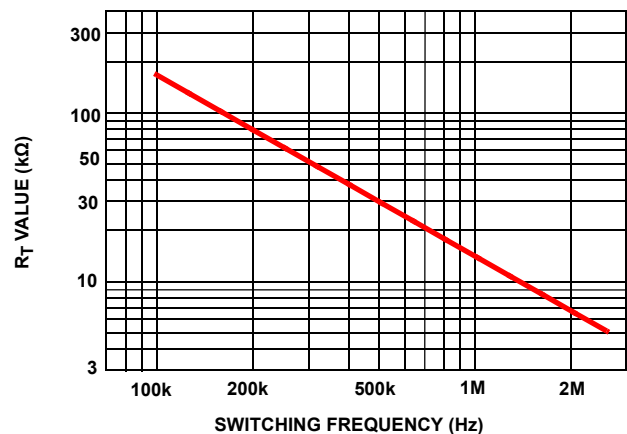

FIGURE 22. FREQUENCY vs  $R_T$  RESISTOR

## Output Regulation

Figure 23 shows the generic feedback resistor circuit for any of the two PWM  $V_{OUT}$ 's; the  $V_{OUT}$  is divided down to equal the reference. All three use a 0.6V internal reference (check the "Electrical Specifications" Table on page 6 for the exact reference value at 24V). The  $R_{UP}$  is connected to the  $V_{OUT}$ ; the  $R_{LOW}$  to GND; the common point goes to the FB pin.

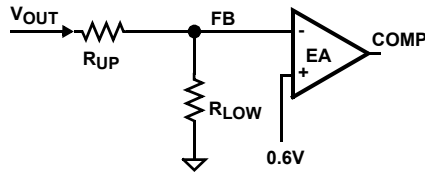

FIGURE 23. OUTPUT REGULATION

$V_{OUT}$  must be greater than 0.6V and 2 resistors are needed, and their accuracy directly affect the regulator tolerance.

$$FB = V_{OUT} \cdot \frac{R_{LOW}}{R_{UP} + R_{LOW}} \quad (\text{EQ. 5})$$

Use Equation 6 to choose the resistor values.  $R_{UP}$  is part of the compensation network for the switchers and should be selected to be compatible; 1k $\Omega$  to 5k $\Omega$  is a good starting value. Find FB from the "Electrical Specifications" table on page 7 (for the right condition), plug in the desired value for  $V_{OUT}$ , and solve for  $R_{LOW}$ .

$$R_{LOW} = \frac{FB \cdot R_{UP}}{V_{OUT} - FB} \quad (\text{EQ. 6})$$

The maximum duty cycle of the ISL6446 approaches 100% at low frequency, but falls off at higher frequency; see the "Electrical Specifications" table on page 7. In addition, there is a minimum UGATE pulse width, in order to properly sense overcurrent. The two switchers are 180° out of phase.

## Linear Regulator

The linear regulator controller is a transconductance amplifier with a nominal gain of 2A/V. The N-Channel MOSFET output buffer can sink a minimum of 50mA.

The reference voltage is 0.6V. With 0V differential at its input, the controller sinks 21mA of current. For better load regulation, it is recommended that the resistor from the LDO input to the base of the PNP (or gate of the PFET) is set so that the sink current at G4 pin is within 9mA to 31mA over the entire load and temperature range.

An external PNP transistor or P-Channel MOSFET pass device can be used. The dominant pole for the loop can be placed at the base of the PNP (or gate of the PFET), as a capacitor from emitter-to-base (source to gate of a PFET). Better load transient response is achieved however, if the dominant pole is placed at the output with a capacitor to ground at the output of the regulator.

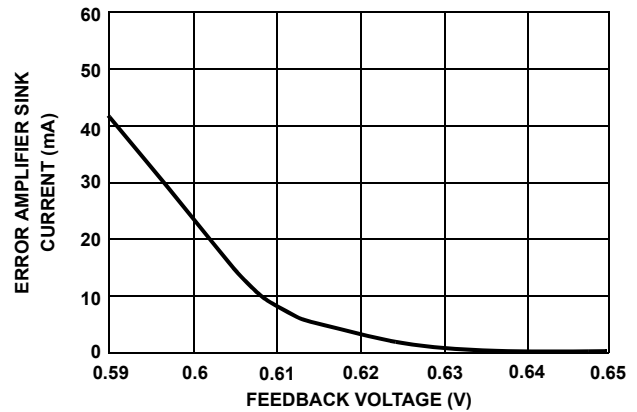

FIGURE 24. LINEAR CONTROLLER GAIN

## Protection Mechanisms

**OCP** - (Function independent for both PWM). The overcurrent function protects the PWM converter from a shorted output by using the upper MOSFET's ON-resistance,  $r_{DS(ON)}$  to monitor the current. This method enhances the converter's efficiency and reduces cost by eliminating a current sensing resistor. The overcurrent function latches off the outputs to provide fault protection. A resistor connected to the drain of the upper MOSFET and OCSET pin programs the overcurrent trip level. The PHASE node voltage will be compared against the voltage on the OCSET pin, while the upper MOSFET is on. A current (typically 110 $\mu$ A) is pulled from the OCSET pin to establish the OCSET voltage. If PHASE is lower than OCSET while the upper MOSFET is on then an overcurrent condition is detected for that clock cycle. The upper gate pulse is immediately terminated and a counter is incremented. If an overcurrent condition is detected for 32 consecutive clock cycles, the ISL6446 output is latched off with gate drivers three-stated. The switcher will restart when the SS/EN pin is externally driven below 1V, or if power is recycled to the chip. During soft-start, both pulse termination current limiting and the 32-cycle counter are enabled.

**UVP** - (Function independent for both PWM). If the voltage on the FB pin falls to 82% (typical) of the reference voltage for 8 consecutive PWM cycles, then the circuit enters into soft-start hiccup mode. During hiccup, the external capacitor on the SS/EN pin is discharged, then released and a soft-start cycle is initiated. The UVP comparator is separate from the one sensing for PGOOD, which should have already detected a problem, before the UVP trips.

**OVP** - (Function independent for both PWM). OVP function is enabled after the soft-start has finished. If voltage on the FB pin rises to 116% (typical) of the reference voltage, the lower gate driver is turned on continuously. If the overvoltage condition continues for 32 consecutive PWM cycles, then that output is latched off with the gate drivers three-stated. The capacitor on the SS/EN pin will not be discharged. The switcher will restart when the SS/EN pin is externally driven below 1V, or if power is recycled to the chip. The OVP comparator is separate from the one sensing for PGOOD, which should have already detected a problem, before the OVP trips.

# Application Guidelines

## PWM Controller

### DISCUSSION

The PWM must be compensated such that it achieves the desired transient performance goals, stability and DC regulation requirements.

The first parameter that needs to be chosen is the switching frequency,  $f_{SW}$ . This decision is based on the overall size constraints and the frequency plan of the end equipment. Smaller space requires higher frequency. This allows the output inductor, input capacitor bank and output capacitor bank to be reduced in size and/or value. The power supply must be designed such that the frequency and its distribution over component tolerance, time and temperature causes minimal interference in RF stages, IF stages, PLL loops, mixers, etc.

### INDUCTOR SELECTION

The output inductor is selected to meet the output voltage ripple requirements and minimize the converter's response time to the load transient. The inductor value determines the converter's ripple current, and the ripple voltage is a function of the ripple current. The ripple current and voltage are approximated by the following [Equations 7](#) and [8](#), where ESR is the output capacitance ESR value.

$$I = \frac{V_{IN} - V_{OUT}}{f_{SW} \cdot L} \cdot \frac{V_{OUT}}{V_{IN}} \quad (\text{EQ. 7})$$

$$\Delta V_{OUT} = \Delta I \times \text{ESR} \quad (\text{EQ. 8})$$

Increasing the value of inductance reduces the ripple current and voltage. However, the large inductance value reduces the converter's response time to a load transient (and usually increases the DCR of the inductor, which decreases the efficiency). Increasing the switching frequency ( $f_{SW}$ ) for a given inductor also reduces the ripple current and voltage.

One of the parameters limiting the converter's response to a load transient is the time required to change the inductor current. Given a sufficiently fast control loop design, the ISL6446 will provide either 0% or 100% duty cycle in response to a load transient. The response time is the time required to slew the inductor current from an initial current value to the transient current level. During this interval, the difference between the inductor current and the transient current level must be supplied by the output capacitor. Minimizing the response time can minimize the output capacitance required.

The response time to a transient is different for the application of load and the removal of load. [Equations 9](#) and [10](#) give the approximate response time interval for application and removal of a transient load:

$$t_{RISE} = \frac{L_{OUT} \times I_{TRAN}}{V_{IN} - V_{OUT}} \quad (\text{EQ. 9})$$

$$t_{FALL} = \frac{L_{OUT} \times I_{TRAN}}{V_{OUT}} \quad (\text{EQ. 10})$$

Where:  $I_{TRAN}$  is the transient load current step,  $t_{RISE}$  is the response time to the application of load, and  $t_{FALL}$  is the response time to the removal of load. With a +5V input source, the worst case response time can be either at the application or removal of load and dependent upon the output voltage setting. Be sure to check both of these equations at the minimum and maximum output levels for the worst case response time.

Finally, check that the inductor  $I_{SAT}$  rating is sufficiently above the maximum output current (DC load plus ripple current).

### OUTPUT CAPACITOR SELECTION

An output capacitor is required to filter the output and supply the load transient current. The filtering requirements are a function of the switching frequency and the ripple current. The load transient requirements are a function of the slew rate ( $di/dt$ ) and the magnitude of the transient load current. These requirements are generally met with a mix of capacitors and careful layout.

Modern microprocessors produce transient load rates above 1A/ns. High frequency capacitors initially supply the transient and slow the current load rate seen by the bulk capacitors. The bulk filter capacitor values are generally determined by the ESR (effective series resistance) and voltage rating requirements rather than actual capacitance requirements.

High frequency decoupling capacitors should be placed as close to the power pins of the load as physically possible. Be careful not to add inductance in the circuit board wiring that could cancel the usefulness of these low inductance components. Consult with the manufacturer of the load on specific decoupling requirements. Keep in mind that not all applications have the same requirements; some may need many ceramic capacitors in parallel; others may need only one.

Use only specialized low-ESR capacitors intended for switching-regulator applications for the bulk capacitors. The bulk capacitor's ESR will determine the output ripple voltage and the initial voltage drop after a high slew-rate transient. An aluminum electrolytic capacitor's ESR value is related to the case size with lower ESR available in larger case sizes. However, the Equivalent Series Inductance (ESL) of these capacitors increases with case size and can reduce the usefulness of the capacitor to high slew rate transient loading. Unfortunately, ESL is not a specified parameter. Work with your capacitor supplier and measure the capacitor's impedance with frequency to select a suitable component. In most cases, multiple electrolytic capacitors of small case size perform better than a single large case capacitor.

### INPUT CAPACITOR SELECTION

Use a mix of input bypass capacitors to control the voltage overshoot across the MOSFETs. Use small ceramic capacitors for high frequency decoupling and bulk capacitors to supply the current needed each time Q1 (upper FET) turns on. Place the small ceramic capacitors physically close to the MOSFETs and between the drain of Q1 and the source of Q2 (lower FET).

The important parameters for the bulk input capacitor are the voltage rating and the RMS current rating. For reliable operation, select the bulk capacitor with voltage and current ratings above

the maximum input voltage and largest RMS current required by the circuit. The capacitor voltage rating should be at least 1.25x greater than the maximum input voltage and a voltage rating of 1.5x is a conservative guideline. The RMS current rating requirement for the input capacitor of a buck regulator is approximately 1/2 the DC load current.

**SWITCHER MOSFET SELECTION**

$V_{IN}$  for the ISL6446 has a wide operating voltage range allowed, so both FETs should have a source-to-drain breakdown voltage ( $V_{DS}$ ) above the maximum supply voltage expected; 20V or 30V are typical values available.

The ISL6446 gate drivers ( $UGATE_x$  and  $LGATE_x$ ) were designed to drive single FETs (for up to ~10A of load current) or smaller dual FETs (up to 4A). Both sets of drivers are sourced by the internal VCC regulator (unless  $V_{IN} = V_{CC} = 5V$ , in which case the gate driver current comes from the external 5V supply). The maximum current of the regulator ( $I_{CC\_max}$ ) is listed in the “Electrical Specifications” table on page 6; this may limit how big the FETs can be. In addition, the power dissipation of the regulator is a major contributor to the overall IC power dissipation (especially as  $C_{in}$  of the FET or  $V_{IN}$  or  $f_{SW}$  increases).

Since  $V_{CC}$  is around 5V, that affects the FET selection in two ways. First, the FET gate-source voltage rating ( $V_{GS}$ ) can be as low as 12V (this rating is usually consistent with the 20V or 30V breakdown chosen above). Second, the FETs must have a low threshold voltage (around 1V), in order to have its  $r_{DS(ON)}$  rating at  $V_{GS} = 4.5V$  in the 10mΩ to 40mΩ range that is typically used for these applications. While some FETs are also rated with gate voltages as low as 2.7V, with typical thresholds under 1V, these can cause application problems. As  $LGATE$  shuts off the lower FET, it does not take much ringing in the  $LGATE$  signal to turn the lower FET back on, while the upper FET is starting to turn on, causing some shoot-through current. Therefore, avoid FETs with thresholds below 1V.

If the power efficiency of the system is important, then other FET parameters are also considered. Efficiency is a measure of power losses from input to output, and it contains two major components: losses in the IC (mostly in the gate drivers) and losses in the FETs. For low duty cycle applications (such as 12V in to 1.5V out), the upper FET is usually chosen for low gate charge, since switching losses are key, while the lower FET is chosen for low  $r_{DS(ON)}$ , since it is on most of the time. For high duty cycles (such as 5V in to 3.3V out), the opposite may be true.

**Feedback Compensation Equations**

This section highlights the design consideration for a voltage mode controller requiring external compensation. To address a broad range of applications, a type-3 feedback network is recommended (see Figure 25).

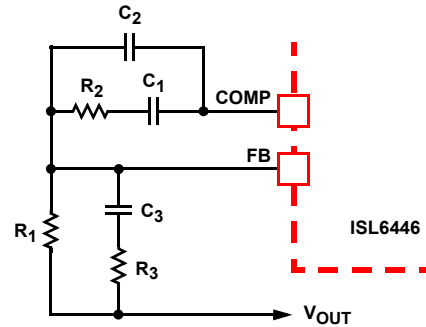

FIGURE 25. COMPENSATION CONFIGURATION FOR ISL6446 CIRCUIT

Figure 26 highlights the voltage-mode control loop for a synchronous-rectified buck converter, applicable to the ISL6446 circuit. The output voltage ( $V_{OUT}$ ) is regulated to the reference voltage,  $V_{REF}$ . The error amplifier output (COMP pin voltage) is compared with the oscillator (OSC) modified sawtooth wave to provide a pulse-width modulated wave with an amplitude of  $V_{IN}$  at the PHASE node. The PWM wave is smoothed by the output filter (L and C). The output filter capacitor bank’s equivalent series resistance is represented by the series resistor E.

The modulator transfer function is the small-signal transfer function of  $V_{OUT}/V_{COMP}$ . This function is dominated by a DC gain, given by  $d_{MAX}V_{IN}/V_{OSC}$ , and shaped by the output filter, with a double pole break frequency at  $F_{LC}$  and a zero at  $F_{CE}$ . For the purpose of this analysis, L and D represent the channel inductance and its DCR, while C and E represent the total output capacitance and its equivalent series resistance.

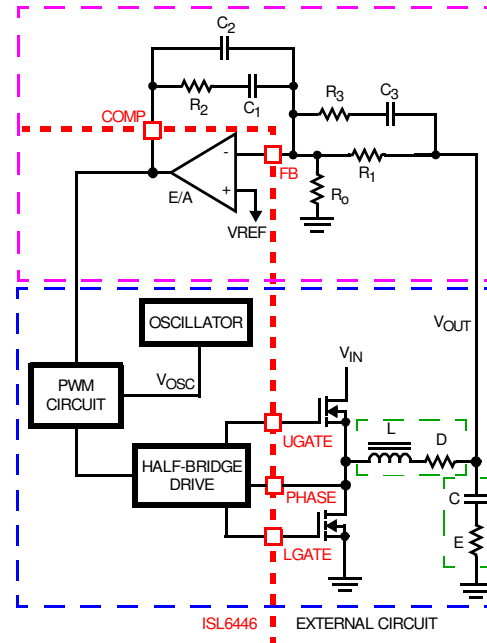

FIGURE 26. VOLTAGE-MODE BUCK CONVERTER COMPENSATION DESIGN

$$F_{LC} = \frac{1}{2\pi \cdot \sqrt{L \cdot C}} \quad (\text{EQ. 11})$$

$$F_{CE} = \frac{1}{2\pi \cdot C \cdot E} \quad (\text{EQ. 12})$$

The compensation network consists of the error amplifier (internal to the ISL6446) and the external  $R_1$  through  $R_3$ ,  $C_1$  through  $C_3$  components. The goal of the compensation network is to provide a closed loop transfer function with high OdB crossing frequency ( $F_0$ ; typically 0.1 to 0.3 of  $f_{SW}$ ) and adequate phase margin (better than  $45^\circ$ ). Phase margin is the difference between the closed loop phase at  $F_{0dB}$  and  $180^\circ$ . The equations that follow relate the compensation network's poles, zeros and gain to the components ( $R_1$ ,  $R_2$ ,  $R_3$ ,  $C_1$ ,  $C_2$ , and  $C_3$ ) in [Figure 26](#). Use the following guidelines for locating the poles and zeros of the compensation network:

1. Select a value for  $R_1$  (1kΩ to 5kΩ, typically). Calculate the value for  $R_2$  for desired converter bandwidth ( $F_0$ ). If setting the output voltage via an offset resistor connected to the FB pin,  $R_0$  in [Figure 26](#), the design procedure can be followed as presented in [Equation 13](#).

$$R_2 = \frac{V_{OSC} \cdot R_1 \cdot F_0}{d_{MAX} \cdot V_{IN} \cdot F_{LC}} \quad (\text{EQ. 13})$$

2. Calculate  $C_1$  such that  $F_{Z1}$  is placed at a fraction of the  $F_{LC}$ , at 0.1 to 0.75 of  $F_{LC}$  (to adjust, change the 0.5 factor to desired number). The higher the quality factor of the output filter and/or the higher the ratio  $F_{CE}/F_{LC}$ , the lower the  $F_{Z1}$  frequency (to maximize phase boost at  $F_{LC}$ ).

$$C_1 = \frac{1}{2\pi \cdot R_2 \cdot 0.5 \cdot F_{LC}} \quad (\text{EQ. 14})$$

3. Calculate  $C_2$  such that  $F_{P1}$  is placed at  $F_{CE}$ .

$$C_2 = \frac{C_1}{2\pi \cdot R_2 \cdot C_1 \cdot F_{CE} - 1} \quad (\text{EQ. 15})$$

4. Calculate  $R_3$  such that  $F_{Z2}$  is placed at  $F_{LC}$ . Calculate  $C_3$  such that  $F_{P2}$  is placed below  $f_{SW}$  (typically, 0.5 to 1.0 times  $f_{SW}$ ).  $f_{SW}$  represents the switching frequency. Change the numerical factor to reflect desired placement of this pole. Placement of  $F_{P2}$  lower in frequency helps reduce the gain of the compensation network at high frequency, in turn reducing the HF ripple component at the COMP pin and minimizing resultant duty cycle jitter.

$$R_3 = \frac{R_1}{f_{SW} \cdot F_{LC} - 1} \quad C_3 = \frac{1}{2\pi \cdot R_3 \cdot 0.7 \cdot f_{SW}} \quad (\text{EQ. 16})$$

It is recommended a mathematical model is used to plot the loop response. Check the loop gain against the error amplifier's open-loop gain. Verify phase margin results and adjust as necessary. The following equations describe the frequency response of the modulator ( $G_{MOD}$ ), feedback compensation ( $G_{FB}$ ) and closed-loop response ( $G_{CL}$ ):

$$G_{MOD}(f) = \frac{d_{MAX} \cdot V_{IN}}{V_{OSC}} \cdot \frac{1 + s(f) \cdot E \cdot C}{1 + s(f) \cdot (E + D) \cdot C + s^2(f) \cdot L \cdot C} \quad (\text{EQ. 17})$$

$$G_{FB}(f) = \frac{1 + s(f) \cdot R_2 \cdot C_1}{s(f) \cdot R_1 \cdot (C_1 + C_2)} \cdot \frac{1}{1 + s(f) \cdot (R_1 + R_3) \cdot C_3} \cdot \frac{1}{(1 + s(f) \cdot R_3 \cdot C_3) \cdot \left(1 + s(f) \cdot R_2 \cdot \left(\frac{C_1 \cdot C_2}{C_1 + C_2}\right)\right)} \quad (\text{EQ. 18})$$

$$G_{CL}(f) = G_{MOD}(f) \cdot G_{FB}(f) \quad (\text{EQ. 19})$$

Where:

$$s(f) = 2\pi \cdot f \cdot j$$

**COMPENSATION BREAK FREQUENCY EQUATIONS**

$$F_{Z1} = \frac{1}{2\pi \cdot R_2 \cdot C_1} \quad (\text{EQ. 20})$$

$$F_{Z2} = \frac{1}{2\pi \cdot (R_1 + R_3) \cdot C_3} \quad (\text{EQ. 21})$$

$$F_{P1} = \frac{1}{2\pi \cdot R_2 \cdot \frac{C_1 \cdot C_2}{C_1 + C_2}} \quad (\text{EQ. 22})$$

$$F_{P2} = \frac{1}{2\pi \cdot R_3 \cdot C_3} \quad (\text{EQ. 23})$$

[Figure 27](#) shows an asymptotic plot of the DC/DC converter's gain vs frequency. The actual Modulator Gain has a high gain peak dependent on the quality factor (Q) of the output filter, which is not shown. Using the previously mentioned guidelines should yield a compensation gain similar to the curve plotted. The open loop error amplifier gain bounds the compensation gain. Check the compensation gain at  $F_{P2}$  against the capabilities of the error amplifier. The closed loop gain,  $G_{CL}$ , is constructed on the log-log graph of [Figure 27](#) by adding the modulator gain,  $G_{MOD}$  (in dB), to the feedback compensation gain,  $G_{FB}$  (in dB). This is equivalent to multiplying the modulator transfer function and the compensation transfer function and then plotting the resulting gain.

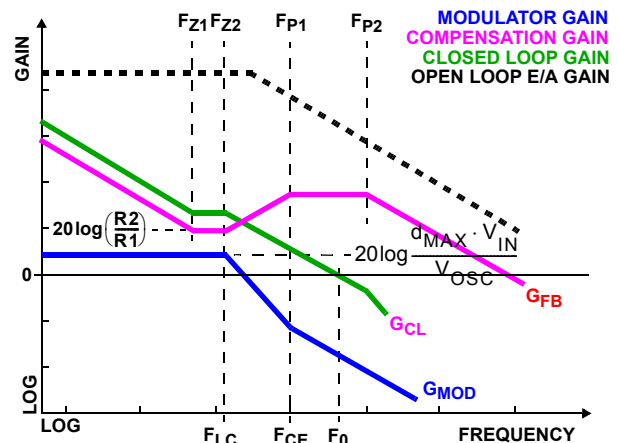

FIGURE 27. ASYMPTOTIC BODE PLOT OF CONVERTER GAIN



A stable control loop has a gain crossing with close to a -20dB/decade slope and a phase margin greater than 45°. Include worst case component variations when determining phase margin. The mathematical model presented makes a number of approximations and is generally not accurate at frequencies approaching or exceeding half the switching frequency. When designing compensation networks, select target crossover frequencies in the range of 10% to 30% of the switching frequency,  $f_{SW}$ .

## Layout Considerations

As in any high frequency switching converter, layout is very important. Switching current from one power device to another can generate voltage transients across the impedances of the interconnecting bond wires and circuit traces. These interconnecting impedances should be minimized by using wide, short printed circuit traces. The critical components should be located as close together as possible using ground plane construction or single point grounding.

Figure 28 shows the critical power components of the converter. To minimize the voltage overshoot, the interconnecting wires indicated by heavy lines should be part of ground or power plane in a printed circuit board. The components shown in Figure 28 should be located as close together as possible. Please note that the capacitors  $C_{IN}$  and  $C_{OUT}$  each represent numerous physical capacitors. Locate the ISL6446 within 1 inch of the MOSFETs,  $Q_1$  and  $Q_2$ . The circuit traces for the MOSFETs' gate and source connections from the ISL6446 must be sized to handle up to 2A peak current.

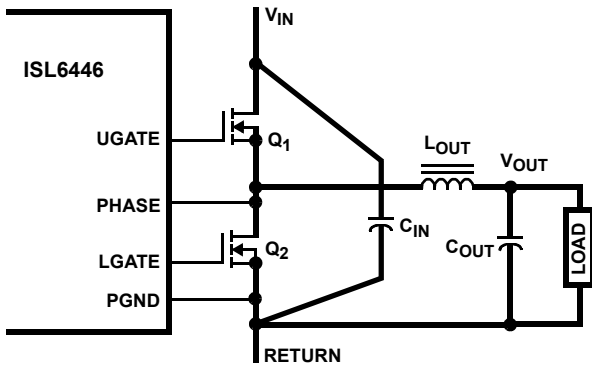

FIGURE 28. PRINTED CIRCUIT BOARD POWER AND GROUND PLANES OR ISLANDS

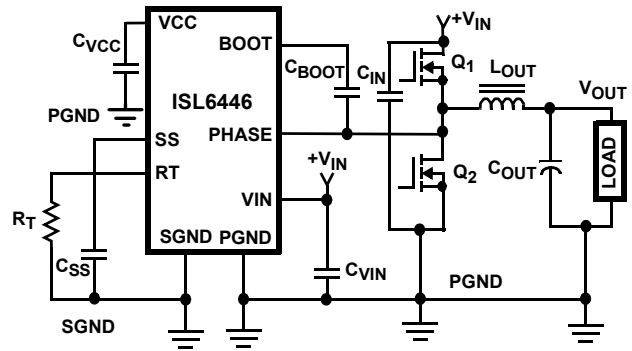

FIGURE 29. PRINTED CIRCUIT BOARD POWER AND GROUND PLANES OR ISLANDS

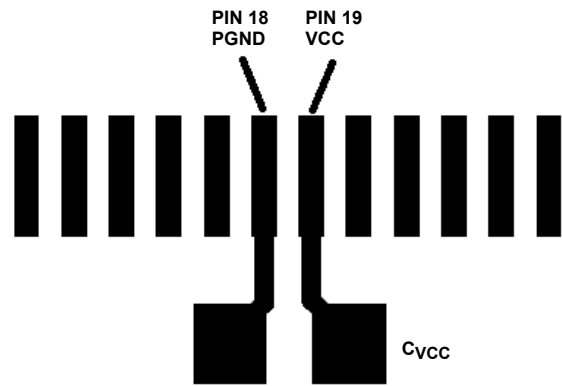

FIGURE 30. DECOUPLING CAPACITOR

Figure 29 shows the circuit traces that require additional layout consideration. Use single point and ground plane construction for the circuits shown. Locate the  $R_T$  resistor as close as possible to the RT pin and the SGND pin. Provide a decoupling capacitor,  $C_{VCC}$ , between VCC and PGND pins and place it as close to the VCC and PGND pins as possible (shown in Figure 30).

For each switcher, minimize any leakage current paths on the SS/EN pin and locate the capacitor,  $C_{SS}$  close to the SS/EN pin because the internal current source is only 30 $\mu$ A. All of the compensation network components for each switcher should be located near the associated COMP and FB pins. Locate the capacitor,  $C_{BOOT}$  as close as practical to the BOOT and PHASE pins (but keep the noisy PHASE plane away from the IC (except for the PHASE pin connection).

The OCSET circuits (see Figure 4 on page 5) should have a separate trace from the upper FET to the OCSET R and C; that will more accurately sense the  $V_{IN}$  at the FET than just tying them to the  $V_{IN}$  plane. The OCSET R and C should be placed near the IC pins.

## Revision History

The revision history provided is for informational purposes only and is believed to be accurate, but not warranted. Please go to web to make sure you have the latest revision.

DATE	REVISION	CHANGE
October 12, 2015	FN7944.2	Updated "Layout Considerations" on page 17.
October 15, 2013	FN7944.1	Figure 1 on page 1: Changed CVCC from common ground tied to PGND earth ground. Figure 4 on page 5: Changed CVIN from common ground tied to PGND earth ground. Figure 29 on page 17: Changed CVCC from common ground tied to PGND earth ground. "Absolute Maximum Ratings" on page 6 ESD rating: changed HBM from 2000V to 2500V and changed MM from 200V to 150V. Converted to new POD format. Added land pattern.
July 10, 2012	FN7944.0	Initial Release.

## About Intersil

Intersil Corporation is a leading provider of innovative power management and precision analog solutions. The company's products address some of the largest markets within the industrial and infrastructure, mobile computing and high-end consumer markets.

For the most updated datasheet, application notes, related documentation and related parts, please see the respective product information page found at [www.intersil.com](http://www.intersil.com).

You may report errors or suggestions for improving this datasheet by visiting [www.intersil.com/ask](http://www.intersil.com/ask).

Reliability reports are also available from our website at [www.intersil.com/support](http://www.intersil.com/support)

© Copyright Intersil Americas LLC 2012-2015. All Rights Reserved.  
All trademarks and registered trademarks are the property of their respective owners.

For additional products, see [www.intersil.com/en/products.html](http://www.intersil.com/en/products.html)

Intersil products are manufactured, assembled and tested utilizing ISO9001 quality systems as noted in the quality certifications found at [www.intersil.com/en/support/qualandreliability.html](http://www.intersil.com/en/support/qualandreliability.html)

*Intersil products are sold by description only. Intersil may modify the circuit design and/or specifications of products at any time without notice, provided that such modification does not, in Intersil's sole judgment, affect the form, fit or function of the product. Accordingly, the reader is cautioned to verify that datasheets are current before placing orders. Information furnished by Intersil is believed to be accurate and reliable. However, no responsibility is assumed by Intersil or its subsidiaries for its use; nor for any infringements of patents or other rights of third parties which may result from its use. No license is granted by implication or otherwise under any patent or patent rights of Intersil or its subsidiaries.*

For information regarding Intersil Corporation and its products, see [www.intersil.com](http://www.intersil.com)

# Package Outline Drawing

## M24.15

24 LEAD SHRINK SMALL OUTLINE PLASTIC PACKAGE (QSOP/SSOP) 0.150" WIDE BODY

Rev 3, 2/13

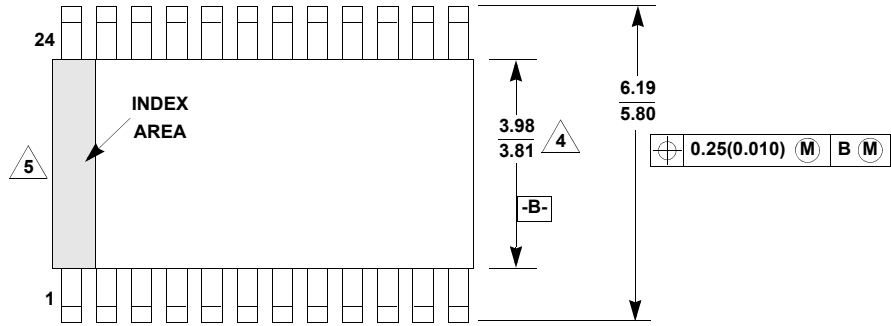

TOP VIEW

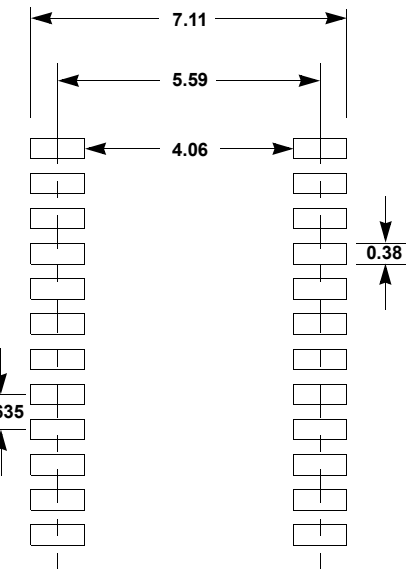
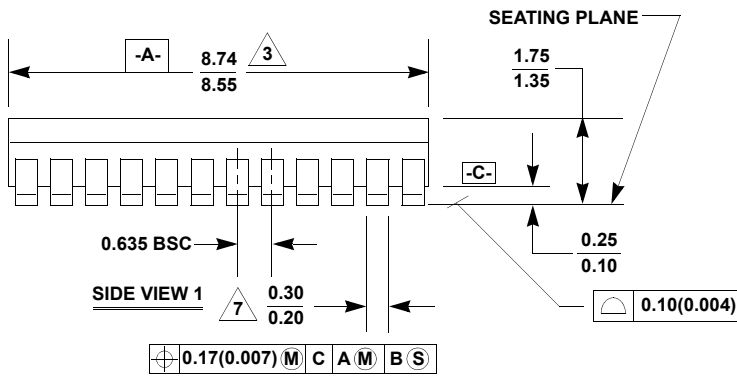

TYPICAL RECOMMENDED LAND PATTERN

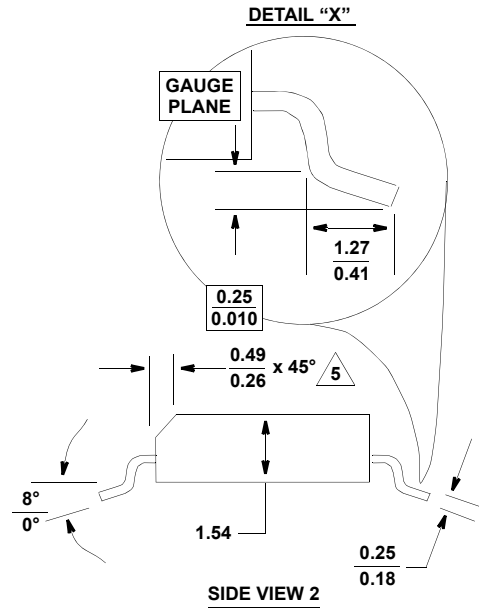

SIDE VIEW 2

**NOTES:**

1. Symbols are defined in the "MO Series Symbol List" in Section 2.2 of Publication Number 95.
2. Dimensioning and tolerancing per ANSI Y14.5M-1982.
3. Package length does not include mold flash, protrusions or gate burrs. Mold flash, protrusion and gate burrs shall not exceed 0.15mm (0.006 inch) per side.
4. Package width does not include interlead flash or protrusions. Interlead flash and protrusions shall not exceed 0.25mm (0.010 inch) per side.
5. The chamfer on the body is optional. If it is not present, a visual index feature must be located within the crosshatched area.
6. Terminal numbers are shown for reference only.
7. Lead width does not include dambar protrusion. Allowable dambar protrusion shall be 0.10mm (0.004 inch) total in excess of "B" dimension at maximum material condition.
8. Controlling dimension: MILLIMETER.