

spec ref	*	dr	Zhi-Jun He	2022/04/28	Amphenol Power Solutions A Division of Amphenol Corporation amphenol-hcc.com	MM	scale	size
tolerance std	ISO 406 ISO 1101	eng	Zhi-Jun He	2022/11/22		ecn no	1:1	A2
TOLERANCES UNLESS OTHERWISE SPECIFIED		f vwr	-	-		rel level	Released	
surface	linear	0.X	±0.5	appr Zheng, Pei-Min 2022/11/22	title PB MINI MEZZ PLUG UNIVERSAL DRAWING product family	cat. no. 10159583	rev A	
		0.XX	±0.25					
		0.XXX	±0.100					
	angular	0°	±2°	Product - Customer Drw		sheet 1 of 4		

PDS: Rev :A

STATUS:Released

Printed: Nov 22, 2022

Amphenol Power Solutions

© 2021 Amphenol Corporation

TABLE 1 (PB MINI MEZZ POWER & SIGNAL)
PLATED THROUGH-HOLE REQUIREMENTS

TOP LAYER DESCRIPTION	DRILLED HOLE DIAMETER	COPPER THICKNESS	TIN-LEAD THICKNESS	NICKEL THICKNESS	GOLD THICKNESS	TIN THICKNESS	SILVER THICKNESS	FINISHED HOLE DIAMETER
	IMMERSION TIN	0.94-1.01 (1.00 DRILL)	0.025-0.050	--	--	--	0.9 - 1.5um	--
IMMERSION SILVER	0.94-1.01 (1.00 DRILL)	0.025-0.050	--	--	--	--	0.15 - 0.65um	0.85 - 0.95
COPPER	0.94-1.01 (1.00 DRILL)	0.025-0.050	--	--	--	--	--	0.85 - 0.95
GOLD	0.94-1.01 (1.00 DRILL)	0.025-0.050	--	0.003 - 0.007	FLASH UP TO 0.0002	--	--	0.84 - 0.95

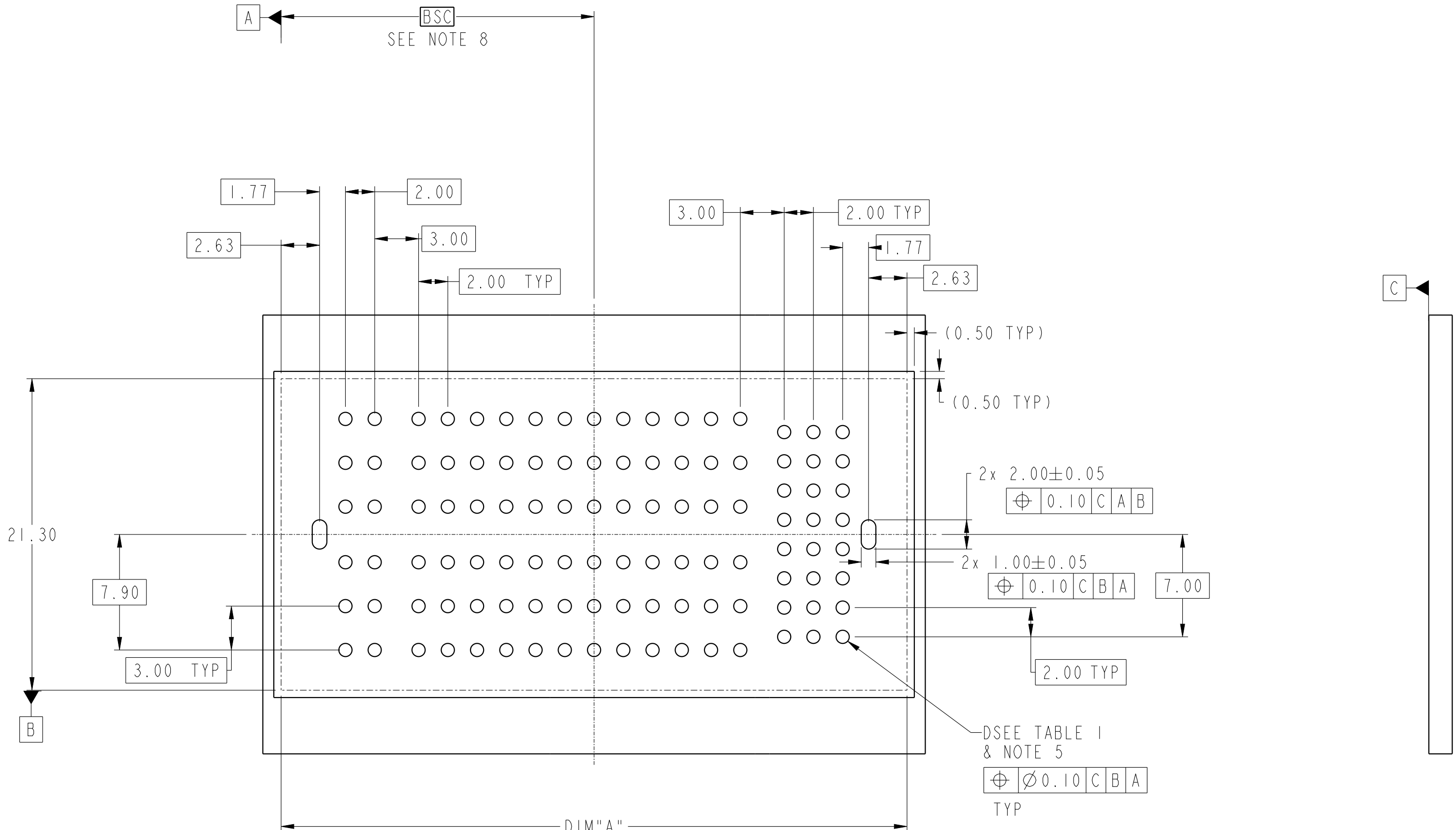

RECOMMENDED PCB LAYOUT
COMPONENT SIDE
NOTE 4

spec ref	*	dr	Zhi-Jun He	2022/04/28	Amphenol Power Solutions A Division of Amphenol Corporation amphenol-hcc.com	MM	scale	1:1	size	A2
tolerance std	ISO 406 ISO 1101	eng	Zhi-Jun He	2022/11/22		ec n no	-	rel level	Released	
surface	linear	0.X	±0.5	projection		PB MINI MEZZ PLUG UNIVERSAL DRAWING	dig no 10159583	cat. no. -	rev A	
	angular	0°	±2°	product family	Product - Customer Drw	sheet 2 of 4				

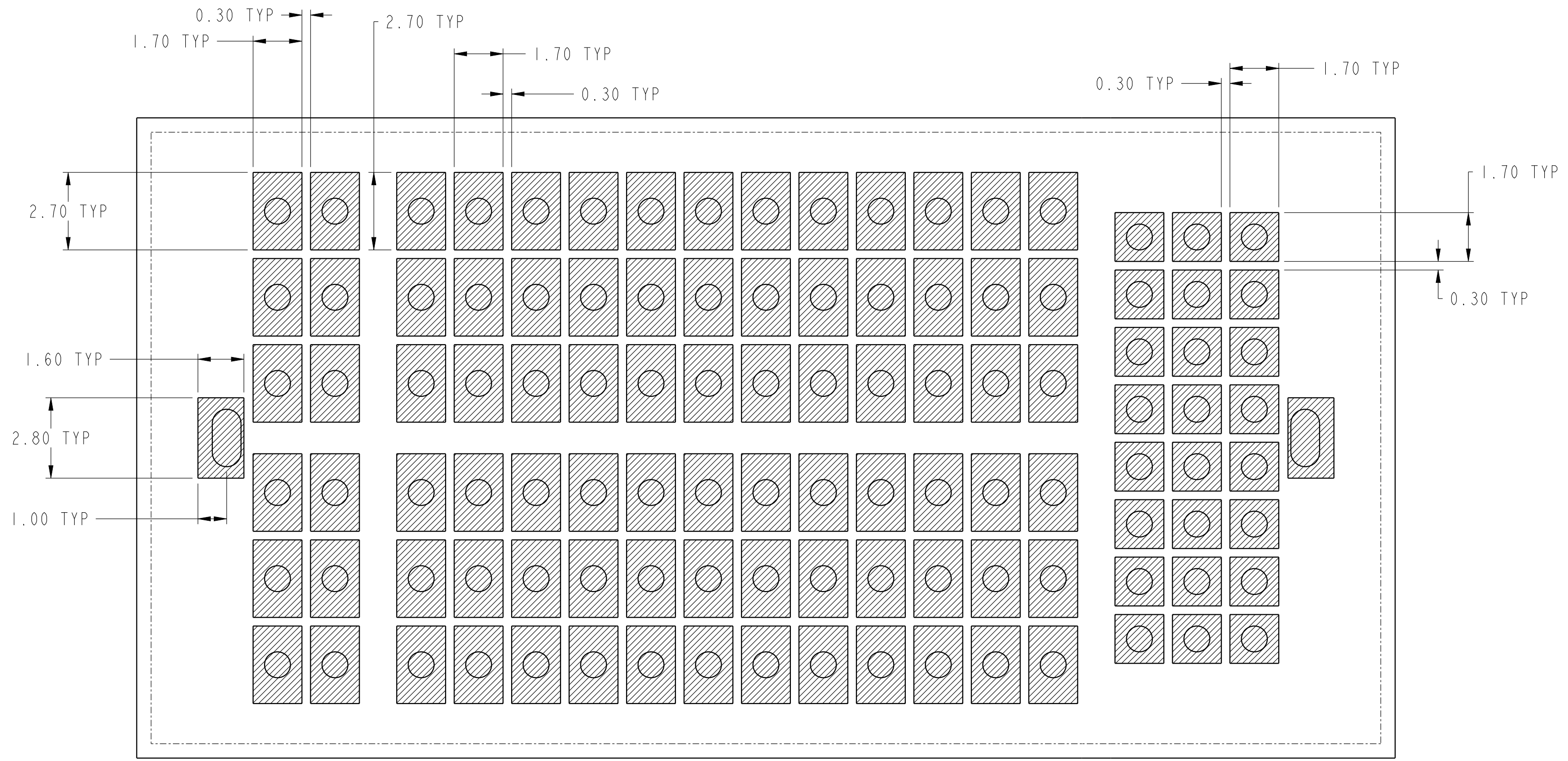

RECOMMENDED STENCIL LAYOUT FOR PIP
TOLERANCE : $\pm 0.05\text{MM}$
STENCIL THICKNESS : 0.25MM

spec ref	*	dr	Zhi-Jun He	2022/04/28	Amphenol Power Solutions A Division of Amphenol Corporation amphenol-hcc.com	MM	scale	1:1	size	A2
tolerance std	ISO 406 ISO 1101	eng	Zhi-Jun He	2022/11/22		ecn no	-	rel level	Released	
surface	ISO 1302	f v w r	-	-		app r	Zheng, Pei-Min	2022/11/22	dig no	10159583
		linear	0.X	± 0.5	projection		title	PB MINI MEZZ PLUG	cat. no.	
			0.XX	± 0.25			product family	Product - Customer Drw	rev	A
		angular	0°	$\pm 2^\circ$				sheet 3 of 4		

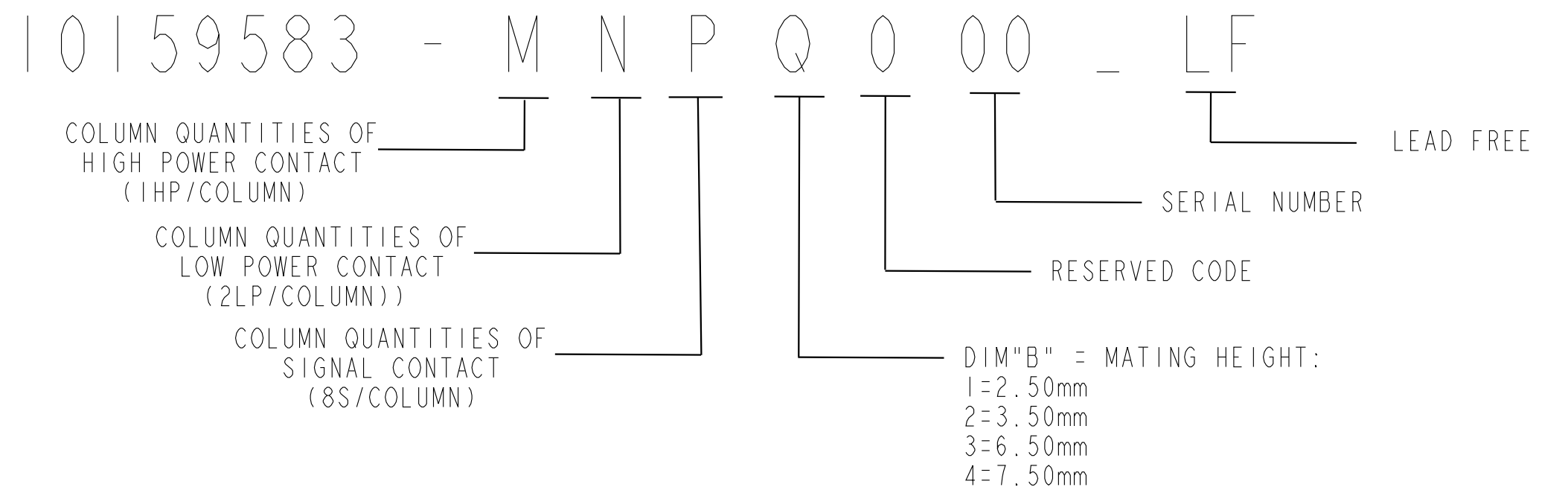
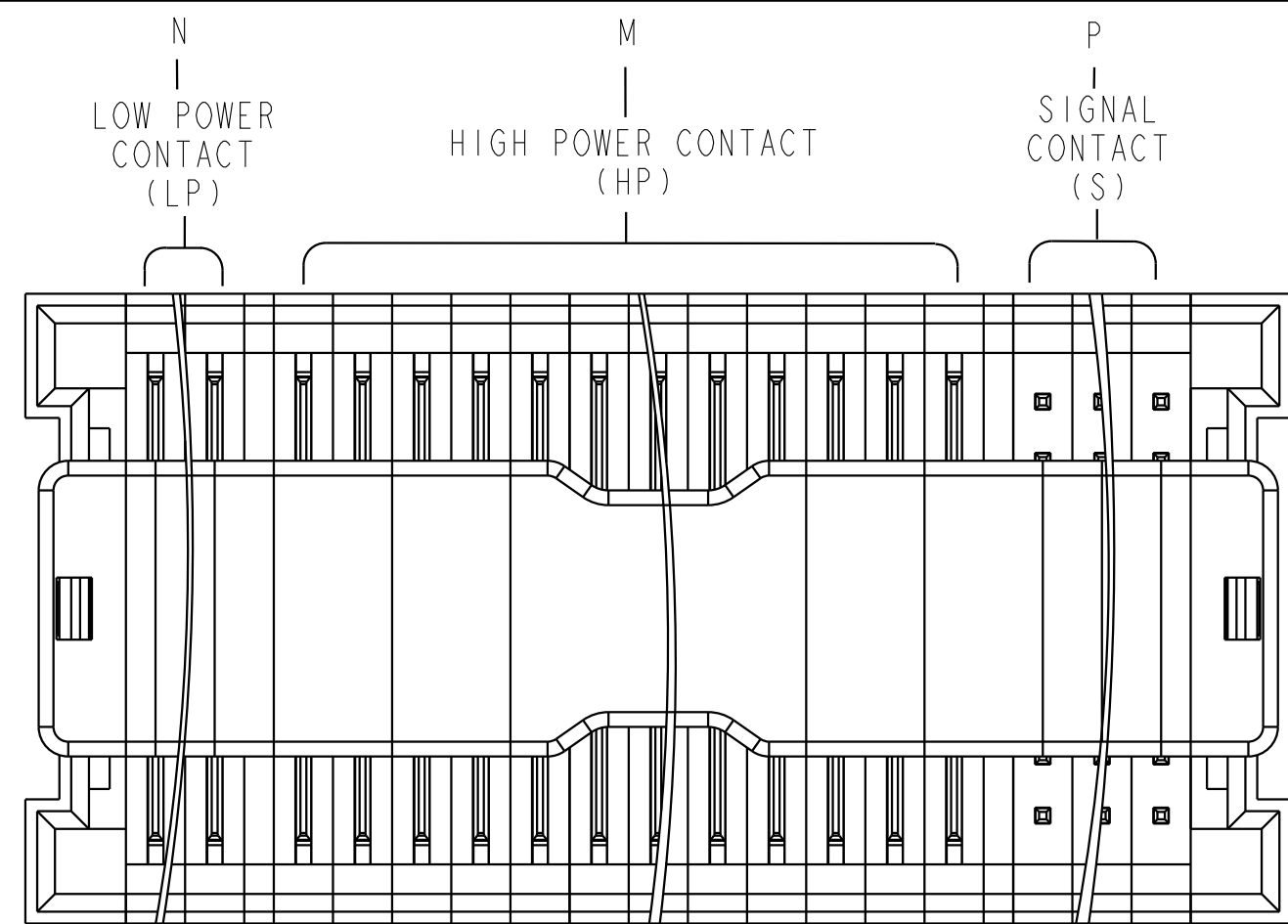

Example: The configuration above is 10159583-C231000LF
 Std PB MINI MEZZ Vertical Header 12HP4LP24S.
 C is 12HP(12column*1HP), 2 is 4LP(2column*2LP),
 3 is 24S(3column*8S), 1 is 2.50mm mating height.
 M & N & P from 1.2.**.8.9.A.B.**.X.Y Etc.(Removed letter I.O.Q.Z)

DIM"A"	3.40 + 2*N + 1(SPACER) + 2*M + 1(SPACER) + 2*P + 3.40			
DIM"B"	2.50	3.50	6.50	7.50
DIM"C"	3.25	4.25	4.25	4.25
SPACERS ARE USED WHEN TWO OR THREE DIFFERENT MODULES ARE CHOSED MODULE MEANS HP & LP & SIGNAL				

TABLE 3: PART NUMBER CODE. PB MINI MEZZ VERTICAL HEADER HP+LP+S CONFIG

NOTES:

- MATERIALS:
 HOUSING: HIGH TEMP THERMOPLASTIC WITH GLASS FIBER, UL94V-0, BLACK.
 POWER CONTACTS: HIGH PERFORMANCE COPPER ALLOY.
 SIGNAL CONTACTS: COPPER ALLOY.
- CONTACT FINISH REFER SECTION 5.3 IN PRODUCT SPECIFICATION.
- PRODUCT MARK:
 PART NUMBER AND DATE CODE TO BE MARKED ON THIS SURFACE.
 THE MARK CAN BE OMITTED IF THERE IS NOT ENOUGH SPACE ON THIS SURFACE.
- RECOMMEND PCB THICKNESS FOR PIP PROCESS : 1.60mm.
- ALL HOLE SIZES ARE FINISHED HOLE SIZES.
- DATUM AND BASIC DIMENSIONS ARE ESTABLISHED BY CUSTOMER.
- THIS PRODUCT MEETS EUROPEAN UNION DIRECTIVES AND OTHER COUNTRY REGULATIONS AS DESCRIBED IN GS-47-0004.
- PRODUCT SPECIFICATION: GS-12-1682.
 APPLICATION SPECIFICATION: GS-20-0686.
 PACKAGE SPECIFICATION: GS-14-2851.
- THE HOUSING WILL WITHSTAND EXPOSURE TO 260°C PEAK TEMPERATURE FOR 10 SECONDS IN A WAVE SOLDER APPLICATION.
- MAXIMUM OVERALL LENGTH IS 80 mm

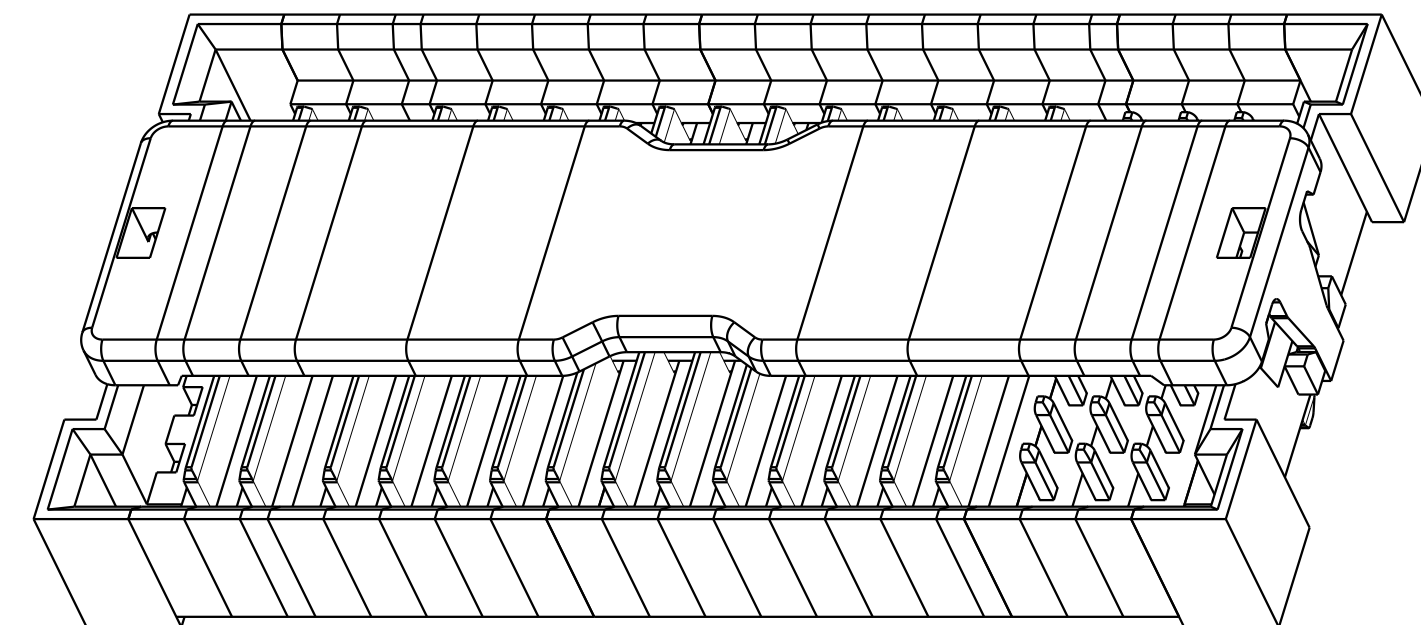

spec ref *	dr Zhi-Jun He 2022/04/28	Amphenol Power Solutions A Division of Amphenol Corporation amphenol-hcc.com	MM	scale 1:1	size A2
tolerance std ISO 406 ISO 1101	eng Zhi-Jun He 2022/11/22		ecn no -	rel level Released	
TOLERANCES UNLESS OTHERWISE SPECIFIED	f v w r - appr Zheng, Pei-Min 2022/11/22		cat. no. 10159583	rev A	
surface	linear 0.X ±0.5 0.XX ±0.25 0.XXX ±0.100	projection	TITLE PB MINI MEZZ PLUG UNIVERSAL DRAWING		product family
ISO 1302	angular 0° ±2°		Product - Customer Drw		sheet 4 of 4