

NOTES:

ELECTRICAL:

- VOLTAGE RATING: 125 VAC.
- CURRENT RATING: 1.25 AMPS PER CONTACT.
- INSULATING RESISTANCE: 500 MEGOHMS MINIMUM.
- DIELECTRIC STRENGTH: CONTACT TO CONTACT, 1000VAC, 60Hz, 1 MIN.
CONTACT TO SHIELD, 1500VAC, 60Hz, 1 MIN.
- CATEGORY 5E CHARACTERISTIC:

MHz	dB, MIN.	dB, MIN.	dB, MAX.
1.0	65	30	0.1
4.0	65	30	0.1
8.0	64.9	30	0.1
10.0	63	30	0.1
16.0	58.9	30	0.2
20.0	57	30	0.2
25.0	55	30	0.2
31.25	53.1	30	0.2
62.5	47.1	24.1	0.3
100.0	43	20	0.4

MECHANICAL:

- SHIELD: STAINLESS STEEL, WITH TIN-DIP ON SOLDER TABS.
- HOUSING: HIGH TEMP THERMOPLASTIC. UL 94V-0, BLACK
- INSERT: HIGH TEMP THERMOPLASTIC UL 94V-0.
- PCB: FR-4.
- CONTACT: PHOSPHOR BRONZE.
SELECTIVE GOLD PLATING FOR MATING SURFACE,
SEE AMPHENOL PART NUMBER FOR DETAIL.
50u" NICKEL UNDERPLATE
100u" MATTE TIN PLATING ON CONTACT SOLDER TAIL.

ENVIRONMENTAL:

- STORAGE: -40° TO +85°.
 - OPERATION: -55° TO +85°.
- MATES WITH MODULAR PLUG CONFORMING TO TIA 1096.
RECOMMENDED SOLDER PROCESS: WAVE SOLDER, PEAK TEMPERATURE
260° FOR 5 SECOND MAXIMUM.
REFLOW SOLDER, PEAK TEMPERATURE
260° FOR 5~8 SECONDS

AMPHENOL PART NUMBER: RJE72-288-1X0X

GOLD PLATING OPTION _____ OPTIONS (SEE BELOW TABLE 1)

- 1=6u" GOLD PLATING
- 2=15u" GOLD PLATING
- 3=30u" GOLD PLATING
- 4=50u" GOLD PLATING

TABLE 1:

RJE722881X01	3.18	2.36
RJE722881X02	2.27	1.57
AMPHENOL P/N:	DIM A	RECOMMEND PCB THICKNESS

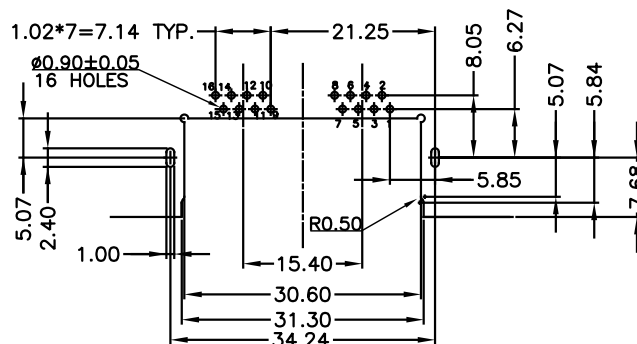
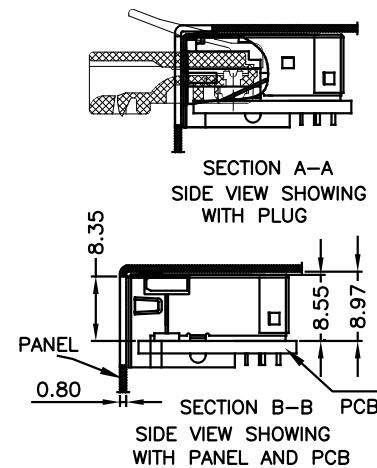
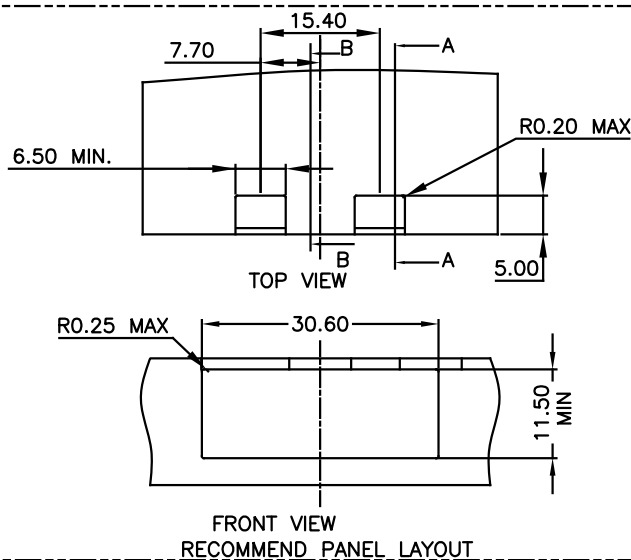

RECOMMENDED PCB LAYOUT
TOLERANCE: ±0.05mm.

THIS DOCUMENT CONTAINS PROPRIETARY INFORMATION AND SUCH INFORMATION MAY NOT BE DISCLOSED TO OTHERS FOR ANY PURPOSE OR USED FOR MANUFACTURING PURPOSES WITHOUT WRITTEN PERMISSION FROM AMPHENOL CANADA CORP.

UNLESS SPECIFIED OTHERWISE	DRAWN	JAMISON C	OCT29/20
PRIMARY UNITS MILLIMETERS	CHECKED	LCHAN	OCT29/20
SECONDARY	M.E. APP'D		
REFERENCE IN PARENTHESES	Q.A. APP'D		
GENERAL TOLERANCES FOR MM	DWG APP'D		
1 DECIMAL PLACE ±0.5	ENG. REL. NO.		
2 DECIMAL PLACES ±0.30	REF.		
3 DECIMAL PLACES ±0.10	THIRD ANGLE PROJECTION		
ANGULAR DEGREE ±3°	DO NOT SCALE DRAWING		

Amphenol Canada Corp. Commercial Products	
MODULAR JACK, 1X2 PORTS, 8 POSITIONS, 8 CONTACTS, SHIELDED WITH TOP&SIDE TABS, WITHOUT LED, SINK PCB TYPE, TAB UP, CAT5E	
DWG NO.	REV A
P-RJE72-288-1X0X	
CODE ID NO. 03554	DWG SIZEN/A SCALE FIT SHEET 1 OF 1