

Figure 1

1. INTRODUCTION

The Tyco Electronics C-Head Adapter Assembly 2119810-1 is designed to run Tyco Electronics 69710-1 Series crimping dies up to, but not including dies designed to run 12-10 PIDG* connectors. Refer to Figure 1 to see the hand tool, adapter.

The Electro-Hydraulic Hand Tool and specific die assemblies must be ordered separately.

For specific crimping die information (including wire preparation, crimping procedures, maintenance and inspection procedures, as well as repair and replacement procedures) refer to the appropriate instruction sheet for the crimping dies.

Refer to Customer Manual 409-10095 for information concerning Electro-Hydraulic Hand Tool 2031400-[].

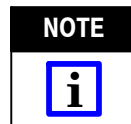

All dimensions on this instruction sheet are in metric units [with inches in brackets]. Figures and illustrations are for identification only, and are not drawn to scale.

2. RECEIVING/INSPECTION

Adapter Assembly 2119810-1 is thoroughly inspected during and after assembly. Prior to packaging and shipping a final series of tests and inspections is made to ensure proper function of the adapter. The following inspections should be performed as a safeguard against potential problems generated in transit.

1. In a well-lighted area, carefully unpack the adapter and inspect each component as it is unpacked.
2. Thoroughly inspect each component for evidence of damage that may have occurred in transit. If any of the components are damaged, file a claim against the carrier and notify Tyco Electronics immediately.

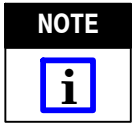

It is IMPORTANT that these instructions, and other documents shipped with the tooling (e.g., drawings, parts lists, tooling manual, etc.), remain with the adapter, head, and hand tool for the benefit of personnel responsible for installation, operation, and maintenance.

The adapter should be inspected at regularly scheduled intervals, depending on care, degree of operator skill, the type and size of product being crimped, and environmental conditions.

3. INSTALLATION/REMOVAL OF ADAPTER ASSEMBLY



Do not operate the Electro-Hydraulic Hand Tool without the C-Head adapter installed. Repeated operation in this manner may result in damage to the Electro-Hydraulic Hand Tool.



To avoid personal injury, be sure to exercise extreme caution when handling the Electro-Hydraulic Hand Tool. Remove the power source (and release hydraulic pressure, if applicable -- see 409-10095) before installing or removing the CERTI-CRIMP II tool head or adapter assembly.

3.1. Adapter Installation/Removal

Refer to the Electro-Hydraulic hand tool manual (409-10095) for instructions on installing and removing the adapter assembly and the crimping heads.

Note that Adapter 2119810-1 does not have a terminal grip thumb button. To remove the adapter, unscrew it completely and then pull the adapter away from the cylinder assembly.

3.2. Die Installation and Removal

A. Installation

If the dies to be installed in the tool require insulation adjustment, refer to the instruction sheet packaged with the dies for adjustment, then proceed as follows:

Each set of dies consists of a moving die and a stationary die. Most moving dies have square corners and the stationary dies have chamfered corners. See Figure 2. Exceptions to this feature will be shown on

instruction sheets covering the use of the particular dies.

1. Remove the power source from the tool.
2. Position the stationary die in the stationary die holder. Turn the die retaining screw sufficiently to hold the die in place. Do not tighten the screw.
3. Position the moving die in the moving die holder. Turn the die retaining screw sufficiently to hold the die in place. Do not tighten the screw.
4. Replace the power source and check the die alignment by pushing the trigger to slowly close the dies, making sure the anvil and indenter are properly aligned.
5. Once the dies are properly aligned, fully tighten the die retaining screws.

B. Removal

To remove or change the dies, remove the power source and then simply loosen the die retaining screws.

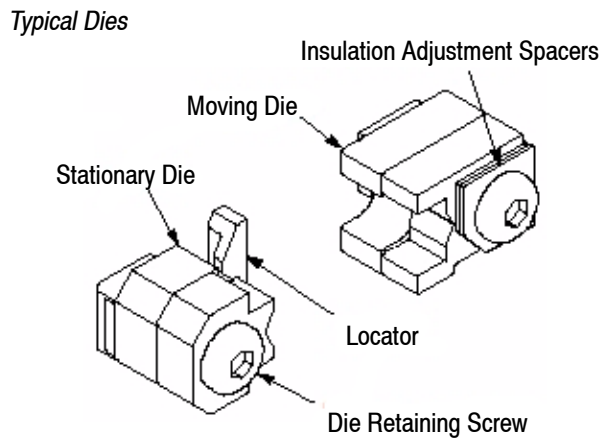

Figure 2

4. OPERATION

The following procedure provides only general information concerning crimping. Refer to the instructions packaged with the die set for detailed information, including wire stripping dimensions and instructions for positioning terminals and splices in the crimpers.



To avoid personal injury, keep fingers clear of the crimping area.

To operate the C-Head Adapter in the Electro-Hydraulic Hand Tool proceed as follows:

1. Insert the contact into the die cavity.
2. Pulse the trigger to advance the lower tooling and hold the contact in place. Do not deform the terminal insulation or wire barrel.
3. Place a pre-stripped wire in the barrel of the contact.
4. Squeeze the tool trigger until the jaws release. When the jaws release, the crimp is complete.

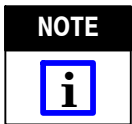

It is not necessary to continue to hold the trigger to retract the tooling. The tooling will retract automatically.

5. Remove the terminated wire.

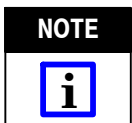

To abort a crimp, press the pressure release device on the power tool. Information on the pressure release device is contained in 409-10095, Section 6, PRESSURE RELEASE/RESET TOOL.

5. PREVENTIVE MAINTENANCE



To avoid personal injury, be sure to exercise extreme caution when handling the Electro-Hydraulic Hand Tool. Remove the power source (and release hydraulic pressure if applicable -- see 409-10095) before performing maintenance.

5.1. Daily Maintenance

Perform the following maintenance on a daily basis:

1. Inspect the dies for wear or damage such as cracks, gouges or chips. If damage is found, return the C-Head Adapter to Tyco Electronics for inspection.
2. Clean the tooling, removing accumulations of dirt and grease on the adapter – particularly:
 - a. in areas where contacts are crimped, and
 - b. in the area where the dies connect to the adapter assembly.
3. Wipe the tooling with a soft, lint-free cloth.

5.2. Yearly Maintenance

Once a year or every 10,000 cycles (whichever comes first) return the adapter to Tyco Electronics for inspection.

6. REPLACEMENT AND REPAIR



To avoid personal injury, be sure to exercise extreme caution when handling the Electro-Hydraulic Hand Tool. Remove the power source (and release hydraulic pressure, if applicable -- see 409-10095) before replacing or repairing components .

Replacement parts are identified in Figure 2 and the table in Figure 3. The recommended spares should be stocked for immediate replacement. Order replacement parts (or return parts) through your Tyco Electronics Representative, or call 1-800-526-5142, or send a facsimile of your purchase order to 717-986-7605. Or write to:

CUSTOMER SERVICE (38-35)
 TYCO ELECTRONICS CORPORATION
 PO BOX 3608
 HARRISBURG PA 17105-3608

For repair services, call the Tooling Assistance Center at 1-800-722-1111.

For spare parts, refer to the table in Figure 3:

Spare Parts		
TE Part Number	Description	Qty.
18023-1	Head Retaining Screw	1
2063866-1	Pinch Warning Label	1

Figure 3

7. RoHS INFORMATION

Information on the presence and location of any substances subject to RoHS (Restriction on Hazardous Substances) can be found at the following website:

<http://www.tycoelectronics.com/customersupport/rohs/supportcenter/>

Click on “Find Compliance Status” and enter equipment part number.

8. REVISION SUMMARY

- Initial release of document